



US00D862449S

(12) **United States Design Patent** (10) **Patent No.:** **US D862,449 S**
Jung (45) **Date of Patent:** **** Oct. 8, 2019**

(54) **CASE FOR ELECTRONIC COMMUNICATIONS DEVICE**

(71) Applicant: **SPIGEN KOREA CO., LTD.**, Seoul (KR)

(72) Inventor: **Soo Ha Jung**, Seoul (KR)

(73) Assignee: **SPIGEN KOREA CO., LTD.**, Seoul (KR)

(**) Term: **15 Years**

(21) Appl. No.: **29/633,781**

(22) Filed: **Jan. 16, 2018**

(51) **LOC (12) Cl.** **14-03**

(52) **U.S. Cl.**
USPC **D14/250**

(58) **Field of Classification Search**
USPC D14/248, 439, 203.3–203.7, 447, 238.1, D14/251–253, 217, 240, 250, 440; D3/201, 218, 247, 269, 273, 301, 303; D13/103, 107–108, 119
CPC H04B 1/3888; H04M 1/0283; H04M 1/0202; A45C 1/06; A45C 11/00; A45C 13/02; A45C 2011/002; A45F 2005/026; A45F 2200/0525; A45F 2200/0516
See application file for complete search history.

D765,638 S 9/2016 Gaylord
D766,226 S * 9/2016 Wu D14/250
D766,885 S * 9/2016 Armstrong D14/250
D767,554 S 9/2016 Bertrand et al.
D775,614 S 1/2017 Kim
D776,098 S * 1/2017 Poon D14/250
D776,104 S * 1/2017 Tien D14/250
D780,164 S 2/2017 Lee
D780,165 S 2/2017 Lee
D780,166 S * 2/2017 Lin D14/250
D780,167 S * 2/2017 Tien D14/250
D782,298 S * 3/2017 de Baschmakoff D9/432
D782,456 S 3/2017 Park et al.
D782,460 S 3/2017 Bertrand et al.
D783,585 S 4/2017 Park
D783,588 S * 4/2017 Chang D14/250
D784,309 S 4/2017 Lee et al.
D786,232 S 5/2017 Kim
D786,851 S 5/2017 Kim
D786,853 S * 5/2017 Friedland D14/250
D789,344 S * 6/2017 Kim D14/250
9,675,150 B2 6/2017 Kim
D791,759 S * 7/2017 Lin D14/250
D792,886 S * 7/2017 Schwibner D14/440
D800,713 S * 10/2017 Kim D14/250
D808,376 S 1/2018 Kim
D828,346 S * 9/2018 Kim D14/250
2012/0018325 A1 1/2012 Kim
2014/0216973 A1 * 8/2014 Chang B65D 81/022
206/521
2015/0001104 A1 1/2015 Kim
2016/0142522 A1 5/2016 Kim
2017/0013925 A1 1/2017 Fathollahi
2017/0027292 A1 2/2017 Hibino
2017/0230072 A1 8/2017 Kim

(56) **References Cited**

U.S. PATENT DOCUMENTS

D368,655 S * 4/1996 Chahed D9/429
D637,590 S 5/2011 Michie et al.
D655,288 S 3/2012 de Jong et al.
D678,871 S 3/2013 Mishan et al.
D682,260 S * 5/2013 Tages D14/250
D694,244 S * 11/2013 Magness D14/440
D709,058 S * 7/2014 Hemesath D14/250
D717,781 S * 11/2014 Kim D14/250
D733,154 S * 6/2015 Armstrong D14/440
9,179,558 B1 * 11/2015 Limber H05K 5/0004
D761,263 S * 7/2016 Brinkman D14/440
D763,854 S * 8/2016 Domke D14/440
D765,634 S 9/2016 McCray et al.

OTHER PUBLICATIONS

SPIGEN, “Installation video of SGP Neo Hybrid Case”, <https://www.youtube.com/watch?v=mVASro4MsEg>, Published on Oct. 30, 2009, Downloaded on Feb. 21, 2019.
Spigen, “Installation video of SGP Neo Hybrid2”, https://www.youtube.com/watch?v=y5_Nd0V0fZo, Published on May 25, 2010, Downloaded on Feb. 21, 2019.
Run Around Tech, “SGP Neo Hybrid Matte Series Case for the iPhone 4”, <https://www.youtube.com/watch?v=fOH74451I-8>, Published on Sep. 22, 2010, Downloaded on Aug. 15, 2018.
“SGP iPhone 4 Case Neo Hybrid Matte Series Gun Metal”, <https://www.amazon.co.uk/iPhone-Case-Hybrid-Matte-Metal/dp/B004F1IQ7E>, Date first available at Amazon.co.uk of Dec. 3, 2010, Earliest review date of Apr. 11, 2011, Downloaded on Aug. 15, 2018.

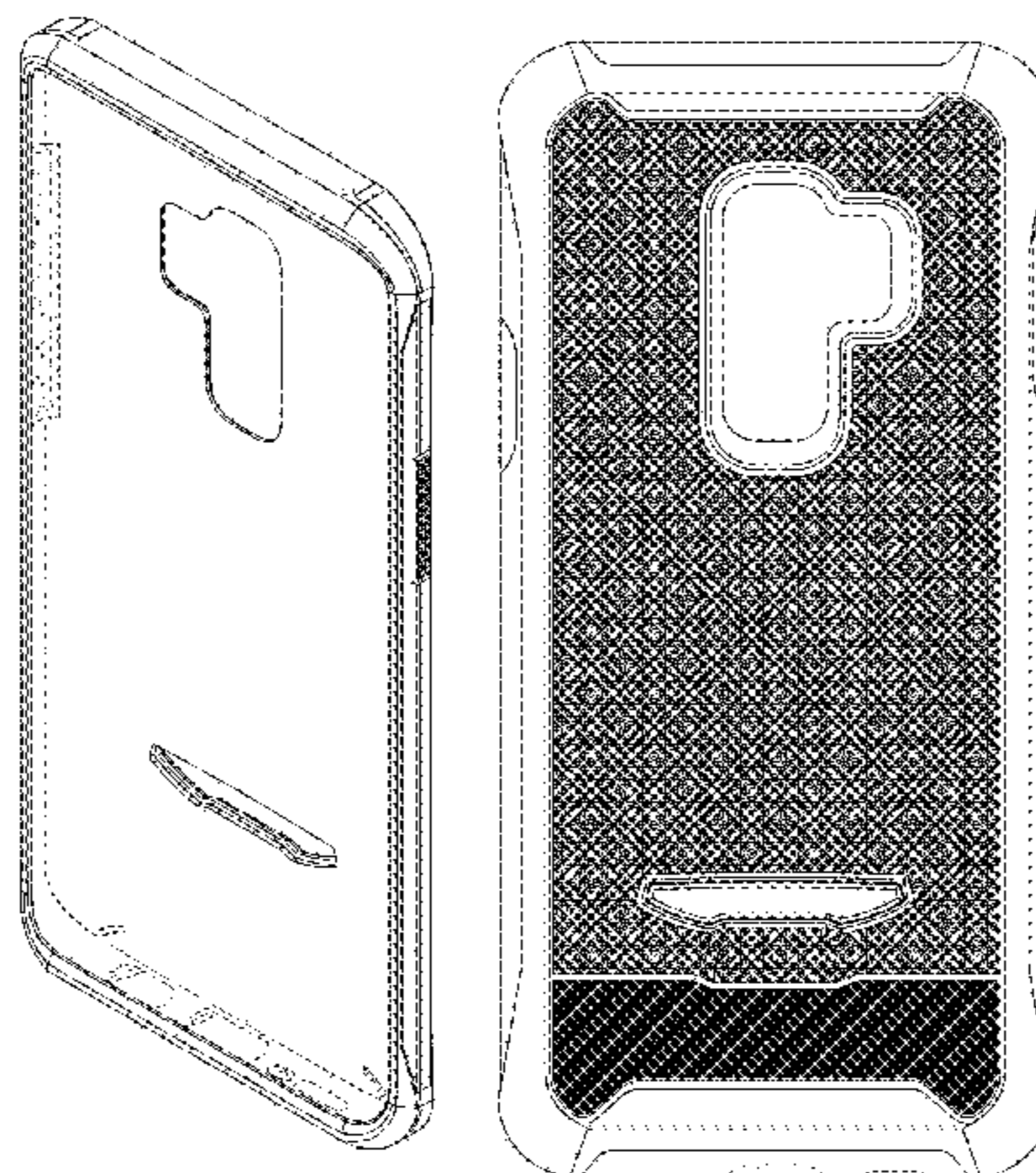

- Spigen, Neo Hybrid Case for Galaxy S3', <https://www.youtube.com/watch?v=IgpahRniVkU>, Published on Jun. 27, 2012, Downloaded on Feb. 21, 2019.
- "Spigen Neo Hybrid Galaxy S4 Case with Flexible Inner Protection and Reinforced Hard Bumper Frame for Galaxy S4 2013—Dante Red", <https://www.amazon.com/Spigen-Hybrid-Flexible-Protection-Reinforced/dp/B00BYJX1Y>, Earliest review date of May 9, 2013, Downloaded on Jan. 22, 2019.
- Metagamers, "Spigen Neo Hybrid iPhone 5 & 5s Case Review", <https://www.youtube.com/watch?v=vTvTYZfSmal>, Published on Jul. 21, 2013, Downloaded on Feb. 21, 2019.
- Danny Winget, "Spigen SGP Neo Hybrid for Galaxy Note 3 Review", <https://www.youtube.com/watch?v=W80JtBDSckk>, Published on Nov. 3, 2013, Downloaded on Dec. 20, 2018.
- "Spigen Neo Hybrid Galaxy S5 Case with Flexible Inner Protection and Reinforced Hard Bumper Frame for Samsung Galaxy S5 2014—Electric Blue", <https://www.amazon.com/Spigen-Flexible-Protection-Reinforced-Samsung/dp/B00I3UWJY>, Earliest review date of Apr. 12, 2014, Downloaded on Jan. 22, 2019.
- "Spigen Neo Hybrid iPhone 6 Case with Flexible Inner Protection and Reinforced Hard Bumper Frame for iPhone 6S / iPhone 6—Gunmetal", <https://www.amazon.com/dp/B00LL6ZPXY>, Earliest review date of Aug. 28, 2014, Downloaded on Dec. 18, 2018.
- "Spigen Neo Hybrid Nexus 6 Case with Flexible Inner Protection and Reinforced Hard Bumper Frame for Google Nexus 6 2014—Dante Red", <https://www.amazon.com/dp/B00OH4HKGC>, Earliest review date of Nov. 16, 2014, Downloaded on Dec. 18, 2018.
- "Spigen Neo Hybrid Galaxy S6 Case with Flexible Inner Protection and Reinforced Hard Bumper Frame for Galaxy S6 2015—Satin Silver", <https://www.amazon.com/dp/B00QU4Q31A>, Earliest review date of Mar. 6, 2015, Downloaded on Dec. 18, 2018.
- "Spigen Neo Hybrid Galaxy S6 Edge Case with Flexible Inner Protection and Reinforced Hard Bumper Frame for Galaxy S6 Edge 2015—Gunmetal", <https://www.amazon.com/dp/B00SV635BG>, Earliest review date of Mar. 19, 2015, Downloaded on Dec. 18, 2018.
- "Spigen Neo Hybrid CC Galaxy S6 Case with Flexible Inner Casing and Reinforced Hard Bumper Frame for Galaxy S6 2015—Satin Silver", <https://www.amazon.com/dp/B00UMDOZLU>, Earliest review date of Mar. 25, 2015, Downloaded on Dec. 18, 2018.
- "Spigen Neo Hybrid CC Galaxy S6 Edge Case with Flexible Inner Casing and Reinforced Hard Bumper Frame for Galaxy S6 Edge 2015—Blue Topaz", <https://www.amazon.com/dp/B00USAPGKQ>, Earliest review date of Apr. 4, 2015, Downloaded on Dec. 18, 2018.
- "Spigen Neo Hybrid Carbon Galaxy S6 Edge Plus Case with Carbon Fiber Design and Reinforced Hard Bumper Frame for Galaxy S6 Edge Plus 2015—Dante Red", <https://www.amazon.com/dp/B010MWHZSO>, Earliest review date of Aug. 18, 2015, Downloaded on Dec. 18, 2018.
- "Spigen Neo Hybrid Crystal Galaxy Note 5 Case with Flexible Inner Casing and Reinforced Hard Bumper Frame for Galaxy Note 5 2015—Champagne Gold", <https://www.amazon.com/dp/B010MWIG1K>, Earliest review date of Aug. 22, 2015, Downloaded on Dec. 18, 2018.
- "iPhone 6s Case, Spigen [Neo Hybrid EX] Premium Bumper [Rose Gold] Clear TPU / PC Frame Slim Dual Layer Premium Case for iPhone 6 (2014) / 6s (2015)—Rose Gold (SGP11725)", <https://www.amazon.com/Spigen-Hybrid-Phone-Flexible-Reinforced/dp/B012PKV30S>, Earliest review date of Aug. 28, 2015, Downloaded on Dec. 18, 2018.
- "Spigen Neo Hybrid Carbon iPhone 6s Case with Carbon Fiber Design and Reinforced Hard Bumper Frame for Apple iPhone 6s / iPhone 6 (2015)—Reventon Yellow", <https://www.amazon.com/dp/B010MVJ508>, Earliest review date of Sep. 1, 2015, Downloaded on Dec. 18, 2018.
- "Spigen Neo Hybrid iPhone 6S Case with Flexible Inner Protection and Reinforced Hard Bumper Frame for iPhone 6S 2015—Gunmetal", <https://www.amazon.com/dp/B010MVIZTE>, Earliest review date of Sep. 1, 2015, Downloaded on Dec. 18, 2018.
- "Spigen Neo Hybrid EX iPhone 6S Plus Case with Flexible Inner Bumper and Reinforced Hard Frame for iPhone 6S Plus/iPhone 6 Plus—Champagne Gold", <https://www.amazon.com/dp/B010MVRRI6>, Earliest review date of Sep. 4, 2015, Downloaded on Dec. 18, 2018.
- "Spigen Neo Hybrid Carbon iPhone 6S Plus Case with Carbon Fiber Design and Reinforced Hard Bumper Frame for iPhone 6S Plus 2015—Gunmetal", <https://www.amazon.com/dp/B010MVRGMQ>, Earliest review date of Sep. 11, 2015, Downloaded on Dec. 18, 2018.
- "Spigen Neo Hybrid Crystal Galaxy S7 Edge Case with Flexible Inner Casing and Reinforced Hard Bumper Frame for Samsung Galaxy S7 Edge 2016—Satin Silver", <https://www.amazon.com/dp/B01A7IDQV4>, Earliest review date of Feb. 22, 2016, Downloaded on Dec. 18, 2018.
- "Spigen Neo Hybrid Galaxy S7 Case with Flexible Inner Protection and Reinforced Hard Bumper Frame for Samsung Galaxy S7 2016—Gunmetal", <https://www.amazon.com/dp/B01B1I6J0E>, Earliest review date of Feb. 27, 2016, Downloaded on Dec. 18, 2018.
- "Spigen Neo Hybrid Galaxy S7 Edge Case with Flexible Inner Protection and Reinforced Hard Bumper Frame for Samsung Galaxy S7 Edge 2016—Satin Silver", <https://www.amazon.com/dp/B01B1I6JMM>, Earliest review date of Feb. 27, 2016, Downloaded on Dec. 18, 2018.
- "Spigen Neo Hybrid Crystal Galaxy S7 Case with Flexible Inner Casing and Reinforced Hard Bumper Frame for Samsung Galaxy S7 2016—Champagne Gold", <https://www.amazon.com/dp/B01B29WCOY>, Earliest review date of Mar. 3, 2016, Downloaded on Dec. 18, 2018.
- "Spigen Neo Hybrid iPhone SE Case with Flexible Inner Protection and Reinforced Hard Bumper Frame for iPhone SE 2016—Gunmetal", <https://www.amazon.com/dp/B01BEJBBSK>, Earliest review date of Apr. 6, 2016, Downloaded on Dec. 18, 2018.
- "Spigen Neo Hybrid Crystal iPhone SE Case with Flexible Inner Casing and Reinforced Hard Bumper Frame for iPhone SE 2016—Rose Gold", <https://www.amazon.com/dp/B01BEJB7TI>, Earliest review date of Apr. 7, 2016, Downloaded on Dec. 18, 2018.
- "Spigen Neo Hybrid Crystal LG G5 Case with Flexible Inner Casing and Reinforced Hard Bumper Frame for LG G5 2016—Champagne Gold", <https://www.amazon.com/dp/B01B1GQKIC>, Earliest review date of Apr. 17, 2016, Downloaded on Dec. 18, 2018.
- "Spigen Neo Hybrid OnePlus 3 Case/OnePlus 3T Case with Flexible Inner Protection and Reinforced Hard Bumper Frame for OnePlus 3 2016—Gunmetal", <https://www.amazon.com/dp/B01H3PF76Q>, Earliest review date of Aug. 9, 2016, Downloaded on Dec. 18, 2018.
- "Spigen Neo Hybrid Crystal iPhone 7 Plus Case with Flexible Casing and Hard Bumper Frame for Apple iPhone 7 Plus 2016—Champagne Gold", <https://www.amazon.com/Spigen-Hybrid-Crystal-iPhone-Flexible/dp/B01GIWHKXI>, Earliest review date of Sep. 8, 2016, Downloaded on Dec. 18, 2018.
- "Spigen Neo Hybrid iPhone 7 Case with Flexible Inner Protection and Reinforced Hard Bumper Frame for iPhone 7 2016—Gunmetal", <https://www.amazon.com/Spigen-Hybrid-Flexible-Protection-Reinforced/dp/B01GIVXKUG>, Earliest review date of Sep. 8, 2016, Downloaded on Dec. 18, 2018.
- "Spigen Neo Hybrid Crystal iPhone 7 Case with Flexible Inner Casing and Reinforced Hard Bumper Frame for iPhone 7 2016—Rose Gold", <https://www.amazon.com/Spigen-Hybrid-Crystal-Flexible-Reinforced/dp/B01GIVXVN2>, Earliest review date of Sep. 14, 2016, Downloaded on Dec. 18, 2018.
- "Spigen Neo Hybrid iPhone 7 Plus Case with Flexible Inner Protection and Hard Bumper Frame for Apple iPhone 7 Plus (2016)—Gunmetal", <https://www.amazon.com/Spigen-Hybrid-iPhone-Flexible-Protection/dp/B01GIWH6H8>, Earliest review date of Sep. 14, 2016, Downloaded on Dec. 18, 2018.
- "Spigen Neo Hybrid Google Pixel XL Case with Flexible Inner Protection and Reinforced Hard Bumper Frame for Google Pixel XL 2016—Satin Silver", <https://www.amazon.com/Spigen-Hybrid-Flexible-Protection-Reinforced/dp/B01LZW1LW3>, Earliest review date of Oct. 23, 2016, Downloaded on Dec. 18, 2018.
- "Spigen Neo Hybrid Crystal Google Pixel Case with Flexible Inner Casing and Reinforced Hard Bumper Frame for Google Pixel 2016—Gunmetal", <https://www.amazon.com/dp/B01M03SL8Y>, Earliest review date of Dec. 14, 2016, Downloaded on Dec. 18, 2018.
- "Spigen Neo Hybrid Crystal Google Pixel XL Case with Flexible Inner Casing and Reinforced Hard Bumper Frame for Google Pixel XL 2016—Gunmetal", <https://www.amazon.com/Spigen-Hybrid->

Crystal-Flexible-Reinforced/dp/B01LZS6PON, Earliest review date of Dec. 15, 2016, Downloaded on Dec. 18, 2018.

* cited by examiner

Primary Examiner — Carla J Wright

(74) *Attorney, Agent, or Firm* — Heedong Chae; Lucem, PC

(57) **CLAIM**

The ornamental design for a case for electronic communications device, as shown and described.

DESCRIPTION

FIG. 1 is a front perspective view of a case for electronic communications device showing my new design;
FIG. 2 is a rear perspective view thereof;
FIG. 3 is a front elevational view thereof;
FIG. 4 is a rear elevational view thereof;
FIG. 5 is a left side elevational view thereof;
FIG. 6 is a right side elevational view thereof;
FIG. 7 is a top plan view thereof;
FIG. 8 is a bottom plan view thereof;
FIG. 9 is a front perspective view showing the inner shell component of the case in isolation;
FIG. 10 is a rear perspective view showing the inner shell component of the case in isolation;
FIG. 11 is a front perspective view showing the outer frame component of the case in isolation;
FIG. 12 is a rear perspective view showing the outer frame component of the case in isolation;

FIG. 13 is an exploded front perspective view showing the components of the case separated;

FIG. 14 is an exploded rear perspective view showing the components of the case separated;

FIG. 15 is an enlarged detail view of the corresponding encircled region in FIG. 2; the surface characteristics of the side button shown in this view are representative of the surface characteristics of the button on the opposite side of the case; and,

FIG. 16 is an enlarged detail view of the corresponding region in FIG. 2.

For clarity of disclosure, the components of the case are shown in isolation in FIGS. 9-12 and separated in FIGS. 13-14. Although the case for electronic communications device, in which the claimed design is embodied, consists of an inner shell component and an outer frame component, the claim is directed to the overall ornamental appearance of the case for electronic communications device in its entirety and does not extend to the ornamental appearance of each of the individual components.

The dot-dash broken line circles in FIGS. 2 and 15-16 delineate portions of the case for electronic communications device that are part of the claimed design and that are shown on an enlarged scale in FIGS. 15-16. The dashed broken lines throughout the drawing figures depict portions of the case for electronic communications device that form no part of the claimed design. The broken lines, regions bounded by dashed broken lines, and the interior of the case (except for the interior edges of the rear openings shown in solid lines) shown in FIGS. 1, 3, 9, and 13 form no part of the claimed design.

1 Claim, 16 Drawing Sheets

FIG. 1

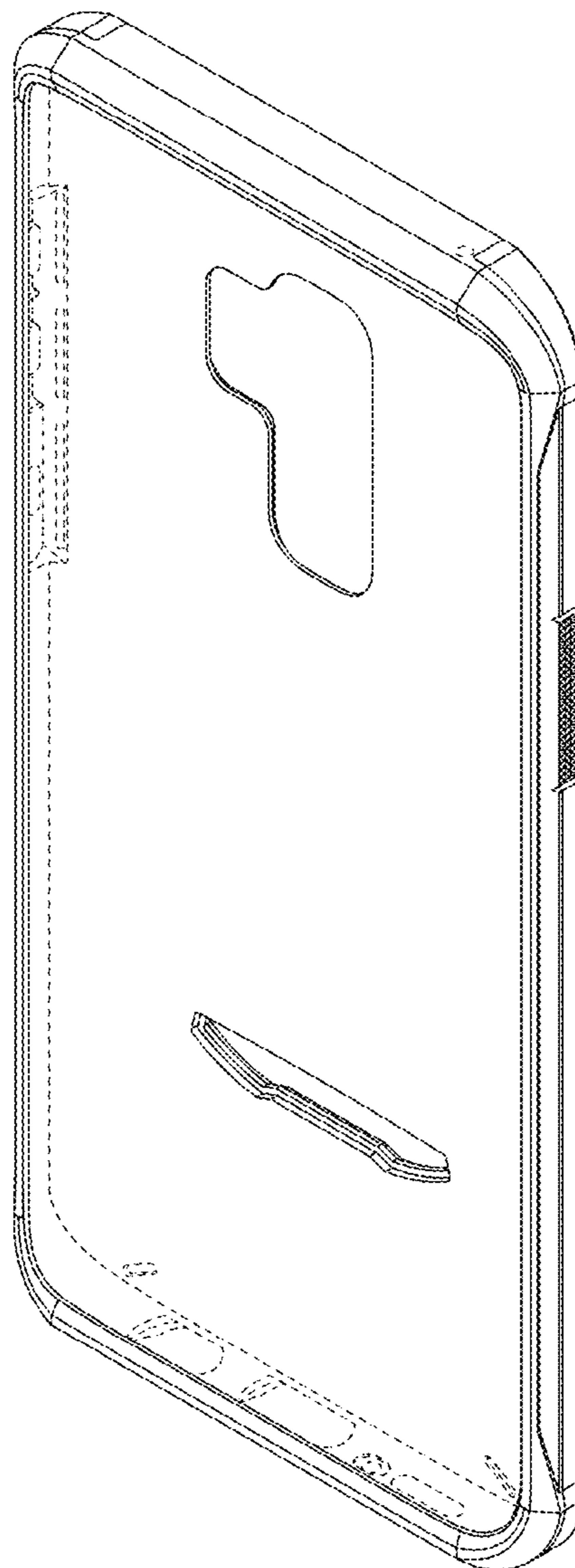

FIG. 2

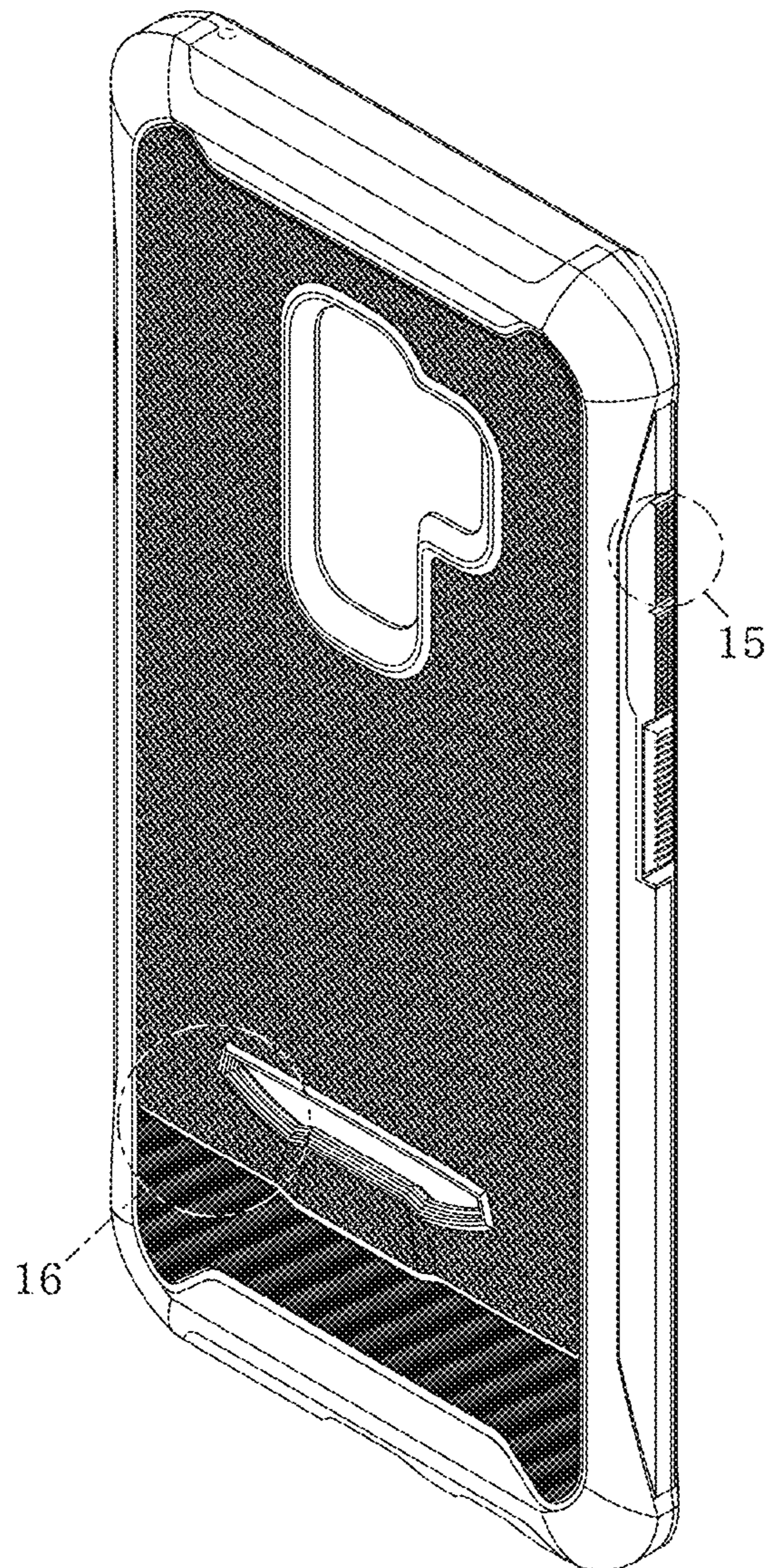

FIG. 3

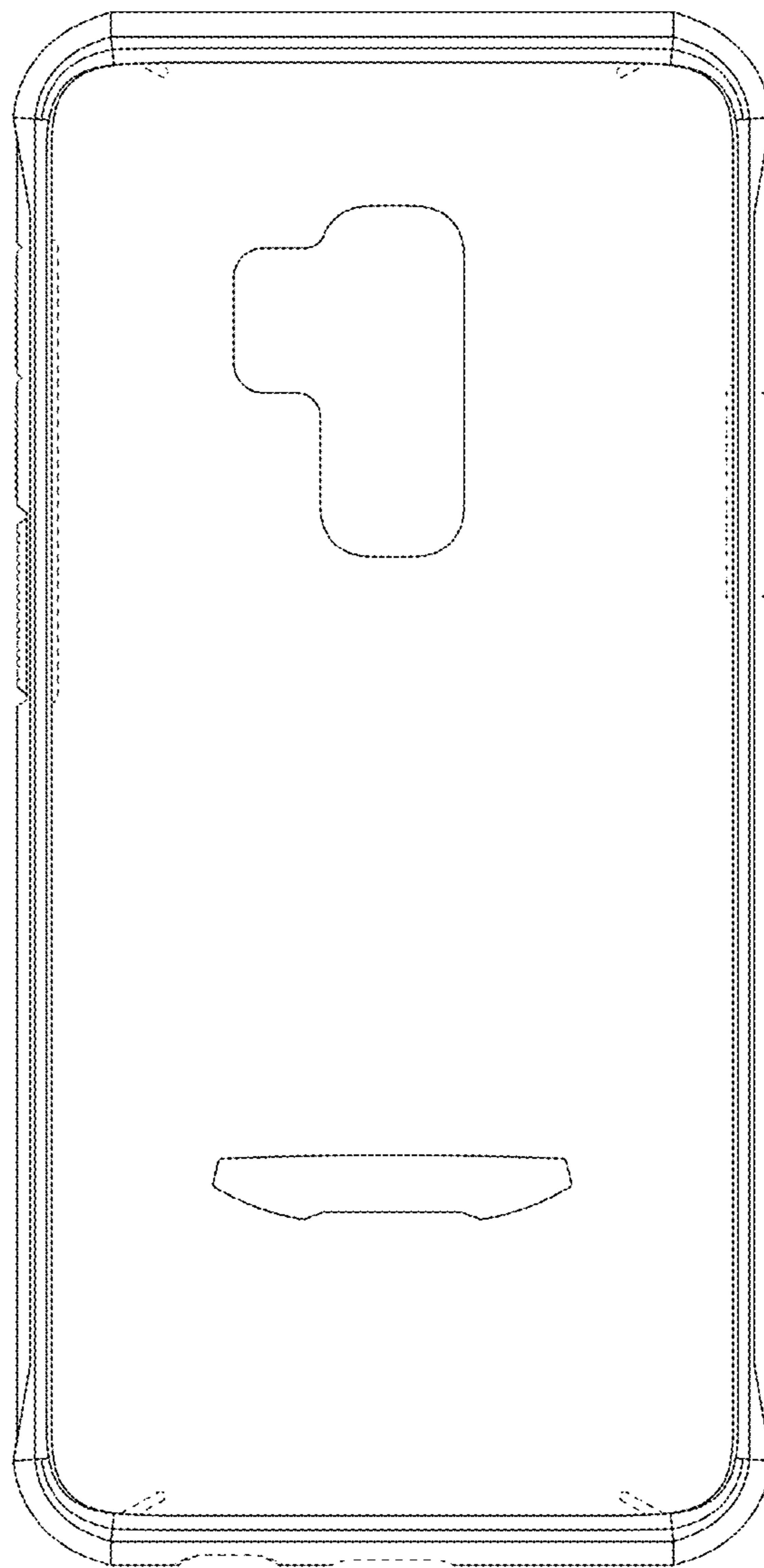

FIG. 4

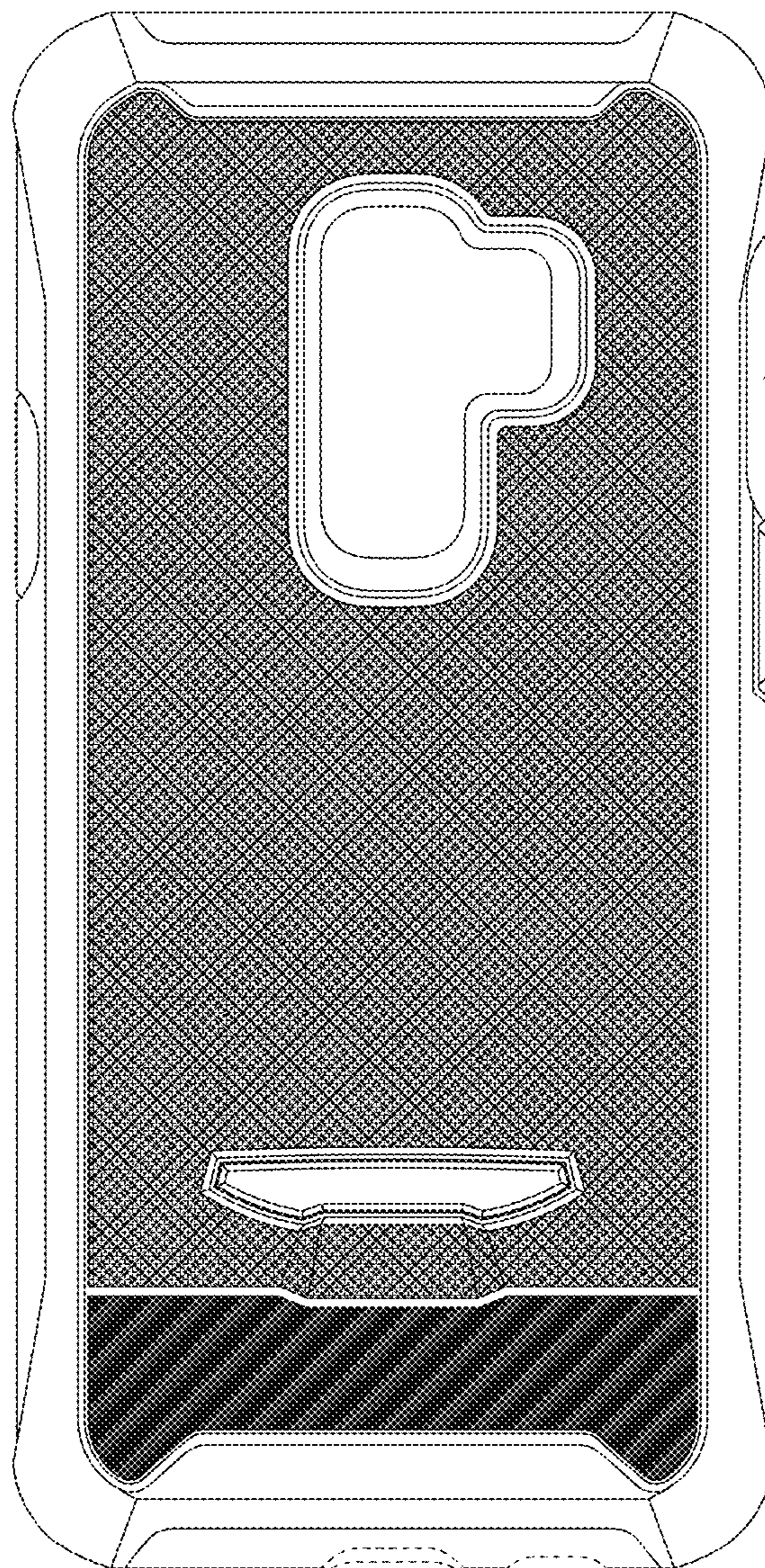

FIG. 5

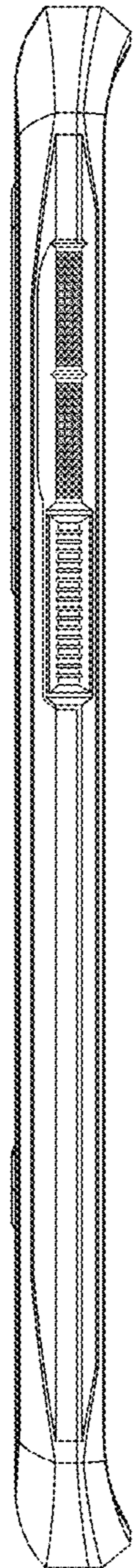

FIG. 6

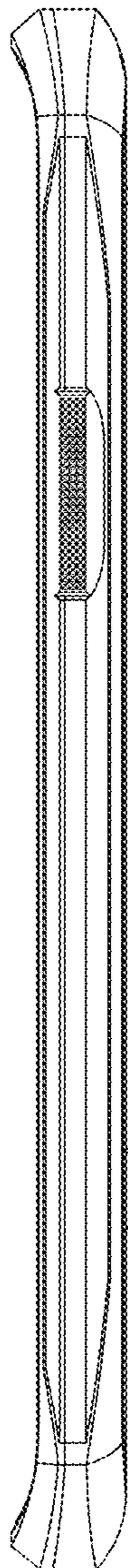

FIG. 7

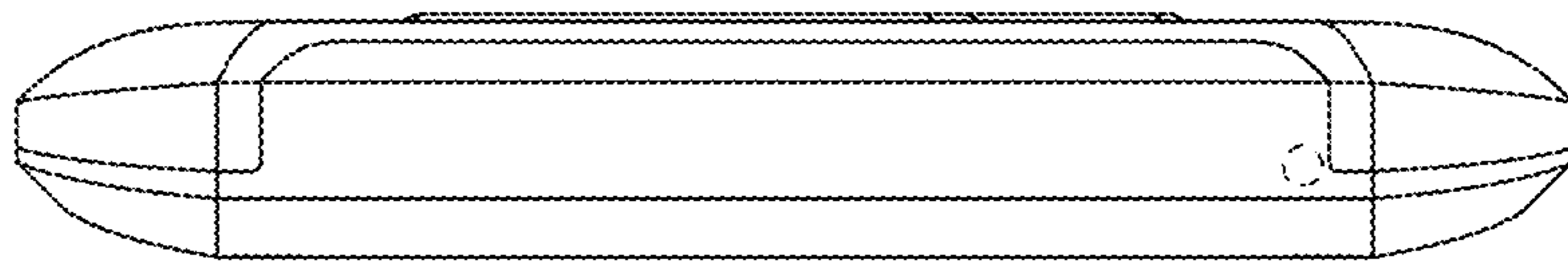

FIG. 8

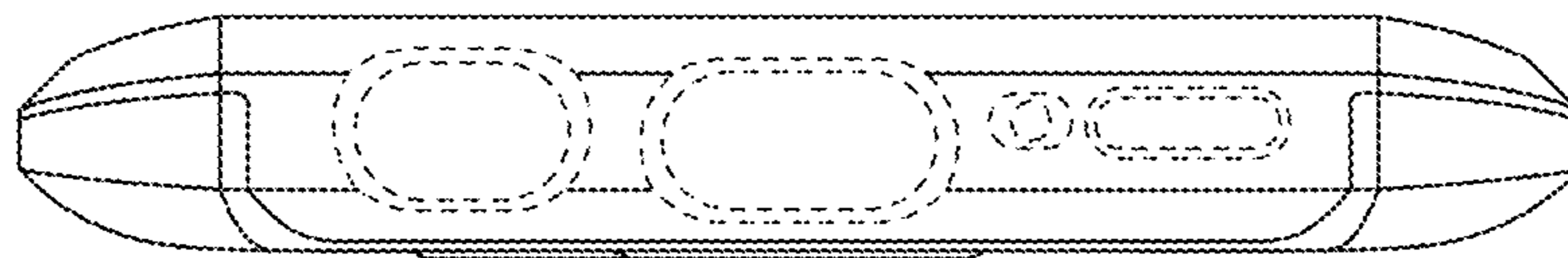

FIG. 9

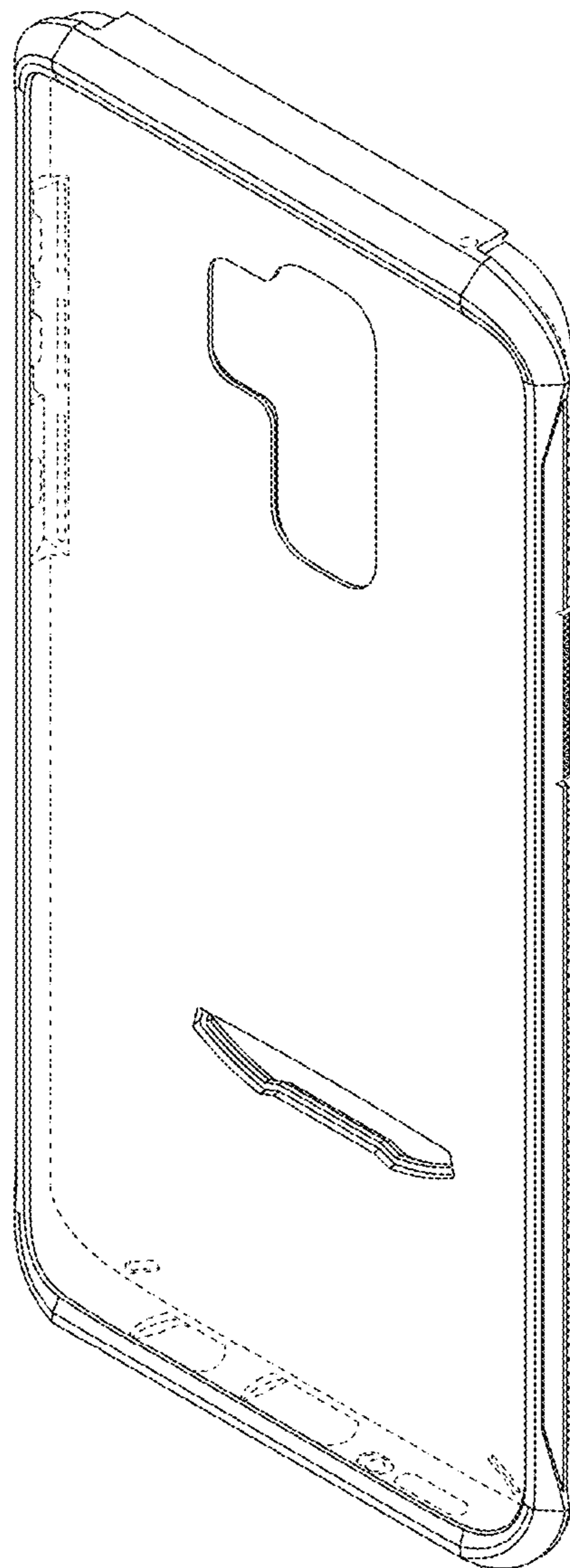

FIG. 10

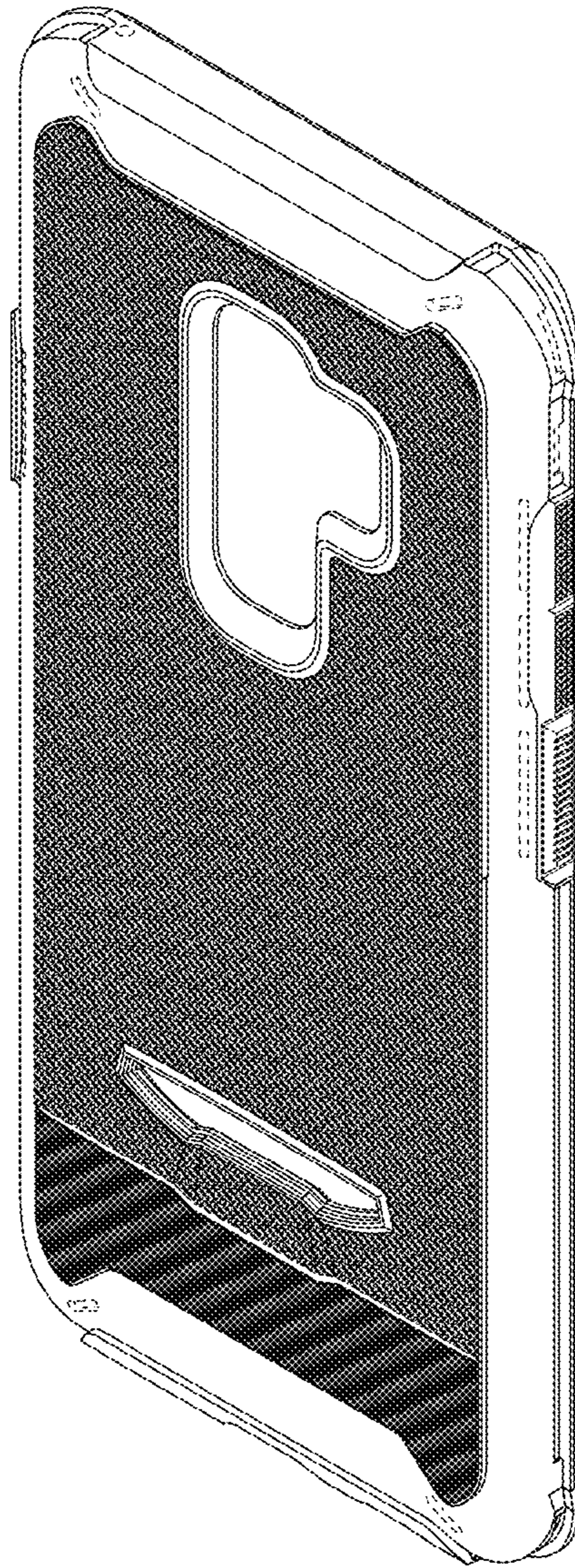

FIG. 11

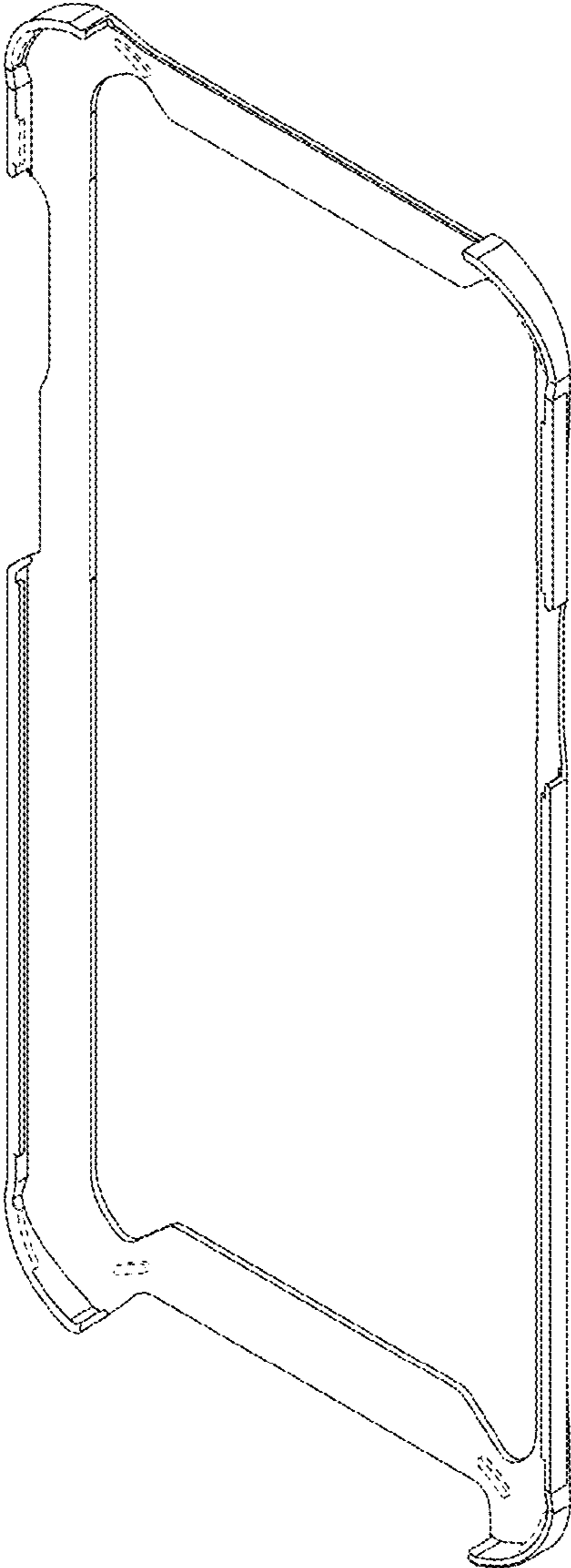

FIG. 12

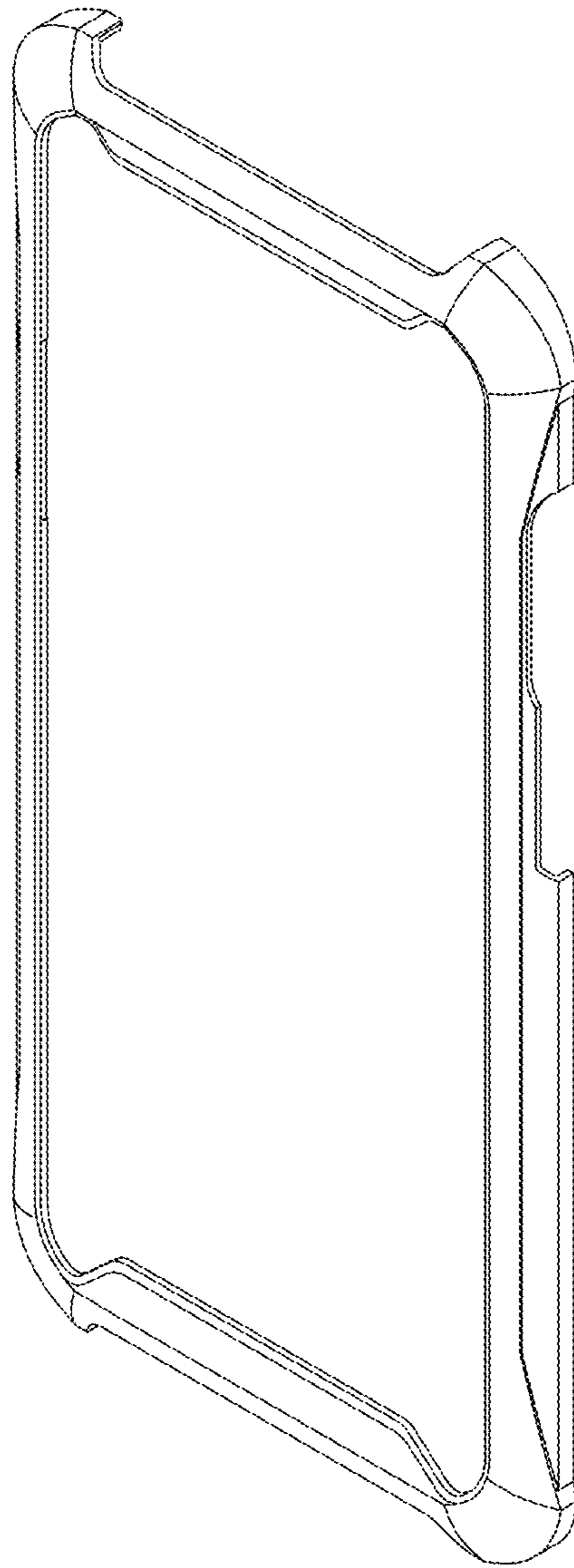

FIG. 13

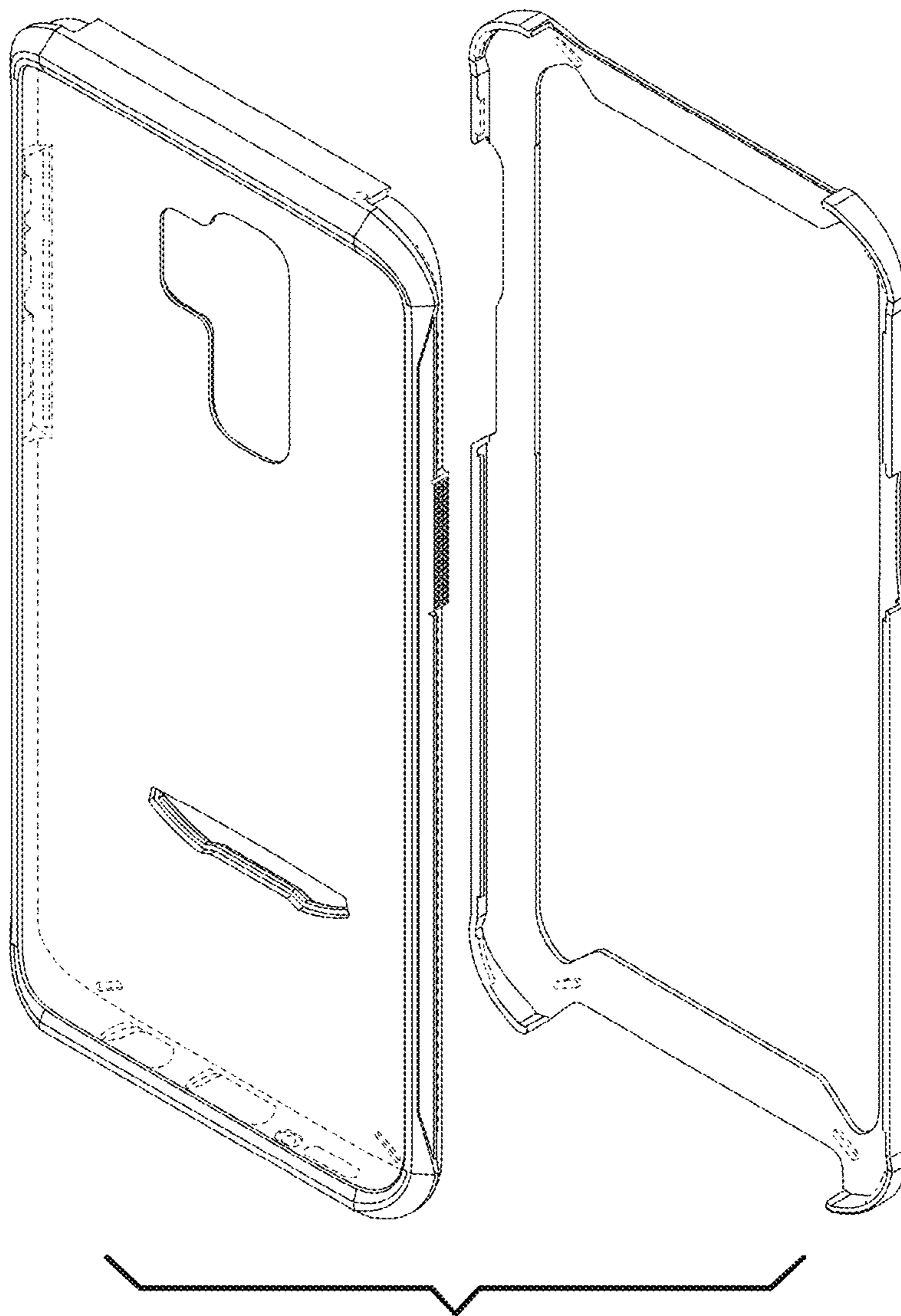

FIG. 14

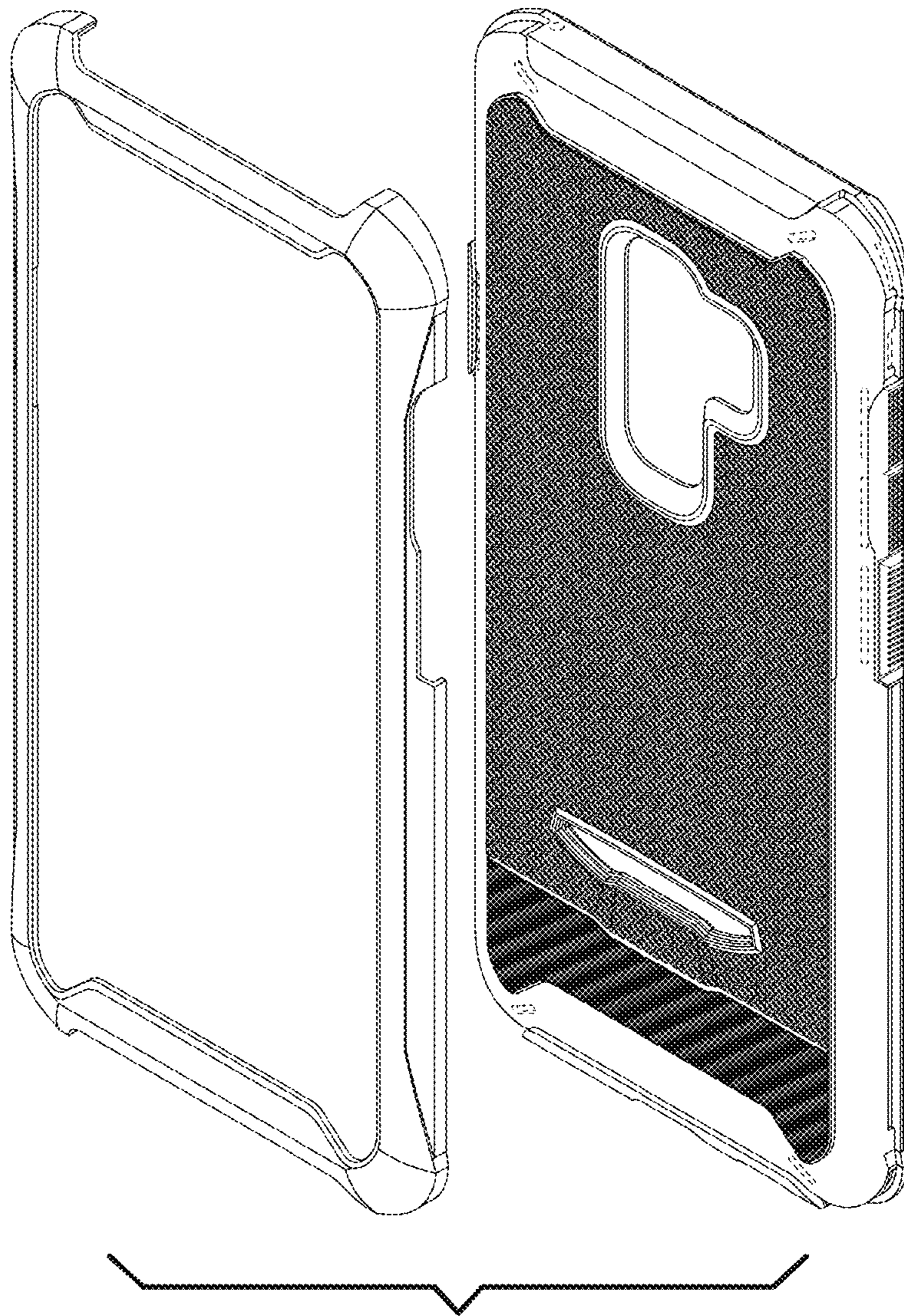

FIG. 15

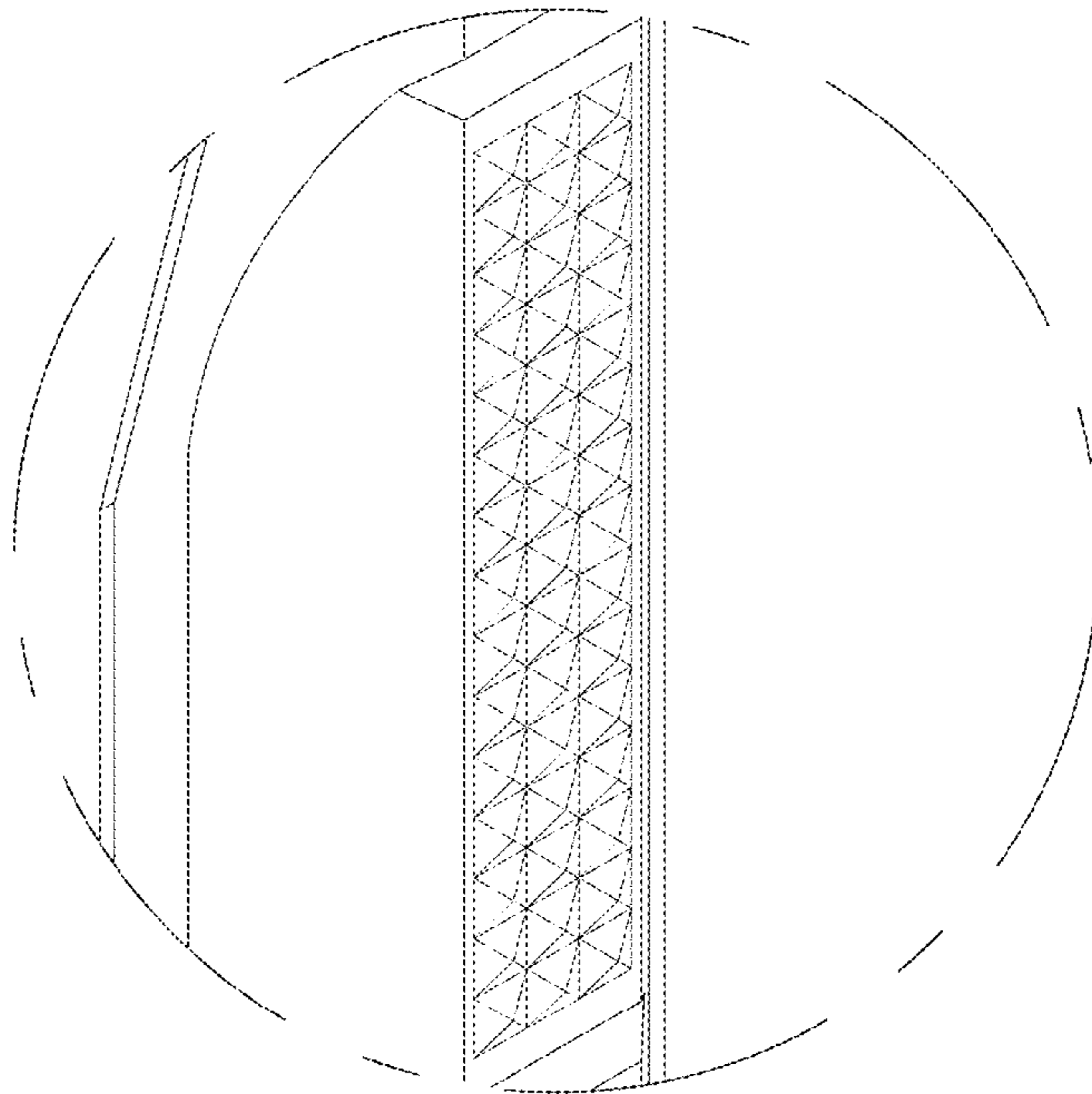

FIG. 16

