



US00D862401S

(12) **United States Design Patent** (10) **Patent No.:** **US D862,401 S**
Bard et al. (45) **Date of Patent:** **** *Oct. 8, 2019**

(54) **REMOTE CONTROL**

- (71) Applicant: **Lutron Technology Company LLC**,
Coopersburg, PA (US)
- (72) Inventors: **Benjamin F. Bard**, Zionsville, PA
(US); **Chris Dimberg**, Easton, PA (US);
Jason C. Killo, Emmaus, PA (US);
David T. Saveri, III, Nazareth, PA
(US); **Daniel L. Twaddell**, Allentown,
PA (US)
- (73) Assignee: **Lutron Electronics Co., Inc.**,
Coopersburg, PA (US)
- (*) Notice: This patent is subject to a terminal dis-
claimer.
- (**) Term: **15 Years**
- (21) Appl. No.: **29/575,339**
- (22) Filed: **Aug. 24, 2016**
- (51) **LOC (12) Cl.** **14-03**
- (52) **U.S. Cl.**
USPC **D13/168**
- (58) **Field of Classification Search**
USPC D13/164, 168, 174; D14/218

(Continued)

(56) **References Cited**

U.S. PATENT DOCUMENTS

- D524,297 S * 7/2006 Lee D14/218
- D531,586 S * 11/2006 Poulet D13/168

(Continued)

Primary Examiner — Selina Sikder

(74) *Attorney, Agent, or Firm* — Glen R. Farbanish;
Philip N. Smith

(57) **CLAIM**

The ornamental design for a remote control, as shown and described.

DESCRIPTION

FIG. 1 is a perspective view of a remote control according to a first embodiment of our new design.

FIG. 2 is a front view thereof.
 FIG. 3 is a left side view thereof.
 FIG. 4 is a right side view thereof.
 FIG. 5 is a top view thereof.
 FIG. 6 is a bottom view thereof.
 FIG. 7 is a perspective view of a remote control according to a second embodiment of our new design.
 FIG. 8 is a front view thereof, the left side, right side, top, and bottom views, respectively, of the second embodiment being identical to the left side, right side, top, and bottom views of the first embodiment.
 FIG. 9 is a perspective view of a remote control according to a third embodiment of our new design.
 FIG. 10 is a front view thereof, the left side, right side, top, and bottom views, respectively, of the third embodiment being identical to the left side, right side, top, and bottom views of the first embodiment.
 FIG. 11 is a perspective view of a remote control according to a fourth embodiment of our new design.
 FIG. 12 is a front view thereof, the left side, right side, top, and bottom views, respectively, of the fourth embodiment being identical to the left side, right side, top, and bottom views of the first embodiment.
 FIG. 13 is a perspective view of a remote control according to a fifth embodiment of our new design.
 FIG. 14 is a front view thereof, the left side, right side, top, and bottom views, respectively, of the fifth embodiment being identical to the left side, right side, top, and bottom views of the first embodiment.
 FIG. 15 is a perspective view of a remote control according to a sixth embodiment of our new design.
 FIG. 16 is a front view thereof, the left side, right side, top, and bottom views, respectively, of the sixth embodiment being identical to the left side, right side, top, and bottom views of the first embodiment.
 FIG. 17 is a perspective view of a remote control according to a seventh embodiment of our new design.
 FIG. 18 is a front view thereof, the left side, right side, top, and bottom views, respectively, of the seventh embodiment being identical to the left side, right side, top, and bottom views of the first embodiment.
 FIG. 19 is a perspective view of a remote control according to an eighth embodiment of our new design; and,

(Continued)

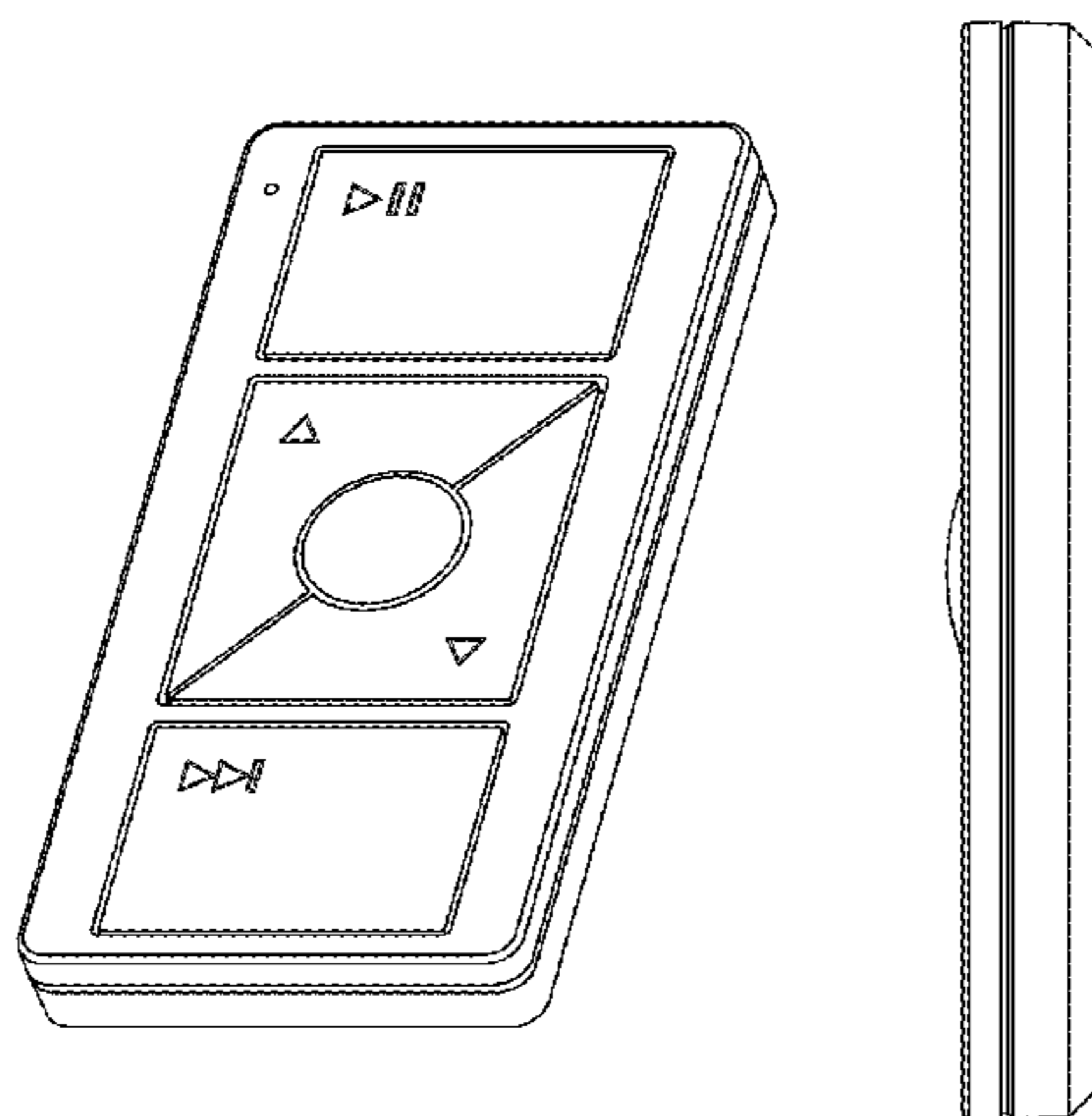

FIG. 20 is a front view thereof, the left side, right side, top, and bottom views, respectively, of the eighth embodiment being identical to the left side, right side, top, and bottom views of the first embodiment.

The rear views form no part of the design and are omitted. The broken lines showing portions of the remote control are for the purpose of illustrating environmental structure and form no part of the claimed design.

1 Claim, 18 Drawing Sheets

(58) **Field of Classification Search**

CPC H03J 1/0025; H03J 9/00; H03J 9/02; H03J 9/04; H03J 9/06; H01H 9/18; H01H 9/0235; H04B 1/202; H05B 33/0803; H05B 33/0863; H05B 37/02; H05B 37/0272; H05B 39/088; H05B 39/041; G05B 11/01; G05B 2219/2642; G08C 17/00; G08C 17/02; G08C 19/28; G08C 23/04; G08C 2201/20; G08C 2201/30; G08C 2201/33; G08C 2201/40; G08C 2201/91; G08C 2201/92

See application file for complete search history.

(56) **References Cited**

U.S. PATENT DOCUMENTS

D557,666 S * 12/2007 Schroter D13/168

D591,272	S *	4/2009	Vitito	D14/218
D592,606	S *	5/2009	Felegy, Jr.	D13/168
D592,611	S *	5/2009	Altonen	D13/171
D600,237	S *	9/2009	Kwon	D14/137
D604,702	S *	11/2009	Felegy, Jr.	D13/168
D619,105	S *	7/2010	Felegy, Jr.	D13/168
D622,710	S *	8/2010	Goransson	D14/218
D631,854	S *	2/2011	Blair	D13/168
D646,232	S *	10/2011	Felegy, Jr.	D13/168
8,291,343	B2 *	10/2012	Kobayashi	H04N 5/44543 715/810
D691,097	S *	10/2013	Lind, III	D13/164
D704,166	S *	5/2014	Sung	D14/218
D714,761	S *	10/2014	O'Neil	D14/218
D738,321	S *	9/2015	Spira	D13/168
D739,830	S *	9/2015	Spira	D13/168
D754,617	S *	4/2016	Altonen	D13/168
D755,739	S *	5/2016	Altonen	D13/168
D768,581	S *	10/2016	Spira	D13/168
2006/0005221	A1 *	1/2006	MacBeth	H04N 5/4401 725/47
2007/0229465	A1 *	10/2007	Sakai	G08C 17/00 345/173
2008/0111491	A1 *	5/2008	Spira	H05B 39/088 315/158
2009/0251352	A1 *	10/2009	Altonen	H01H 9/025 341/176
2011/0266122	A1 *	11/2011	Zaharchuk	H01H 9/18 200/308

* cited by examiner

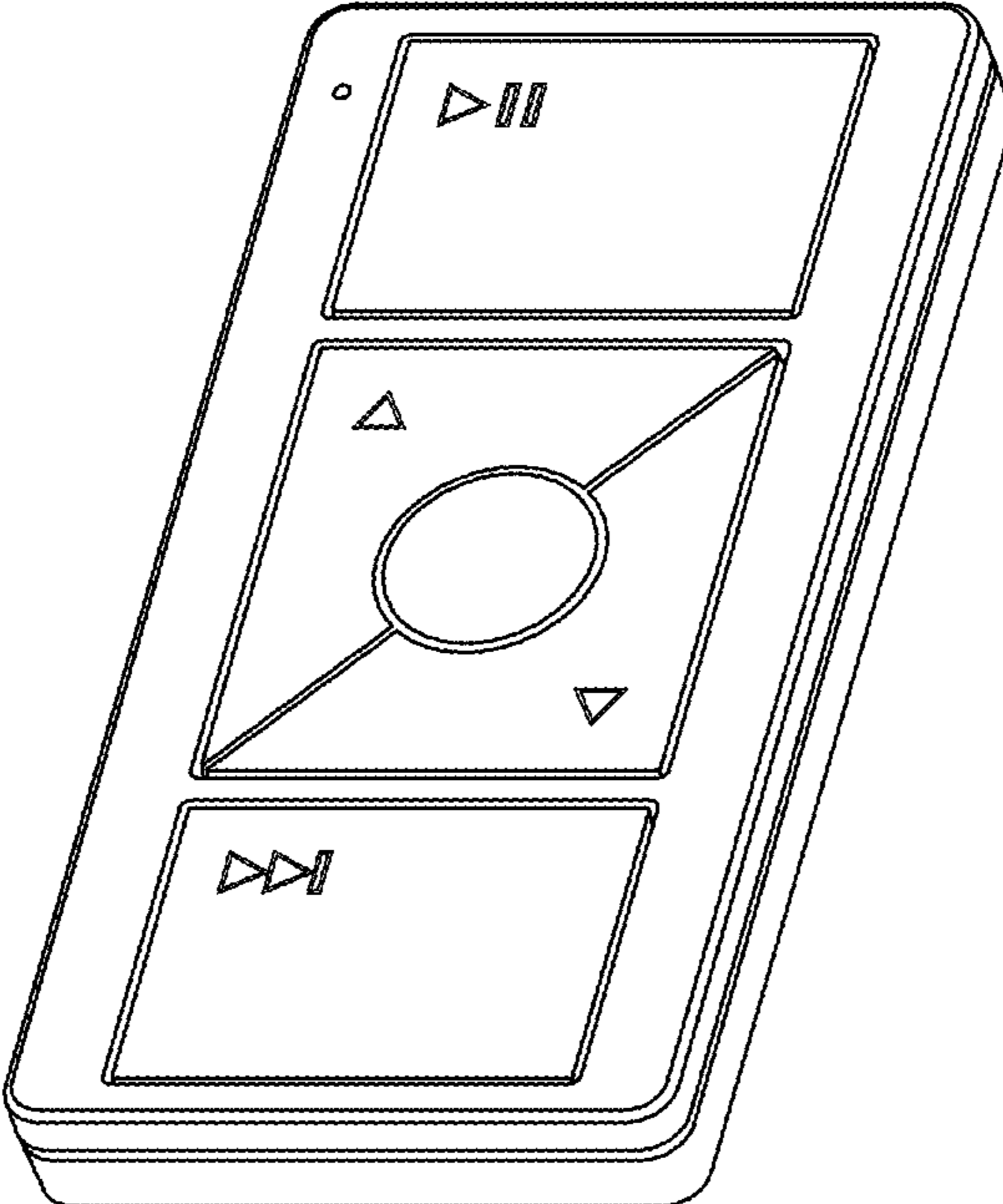

Fig. 1

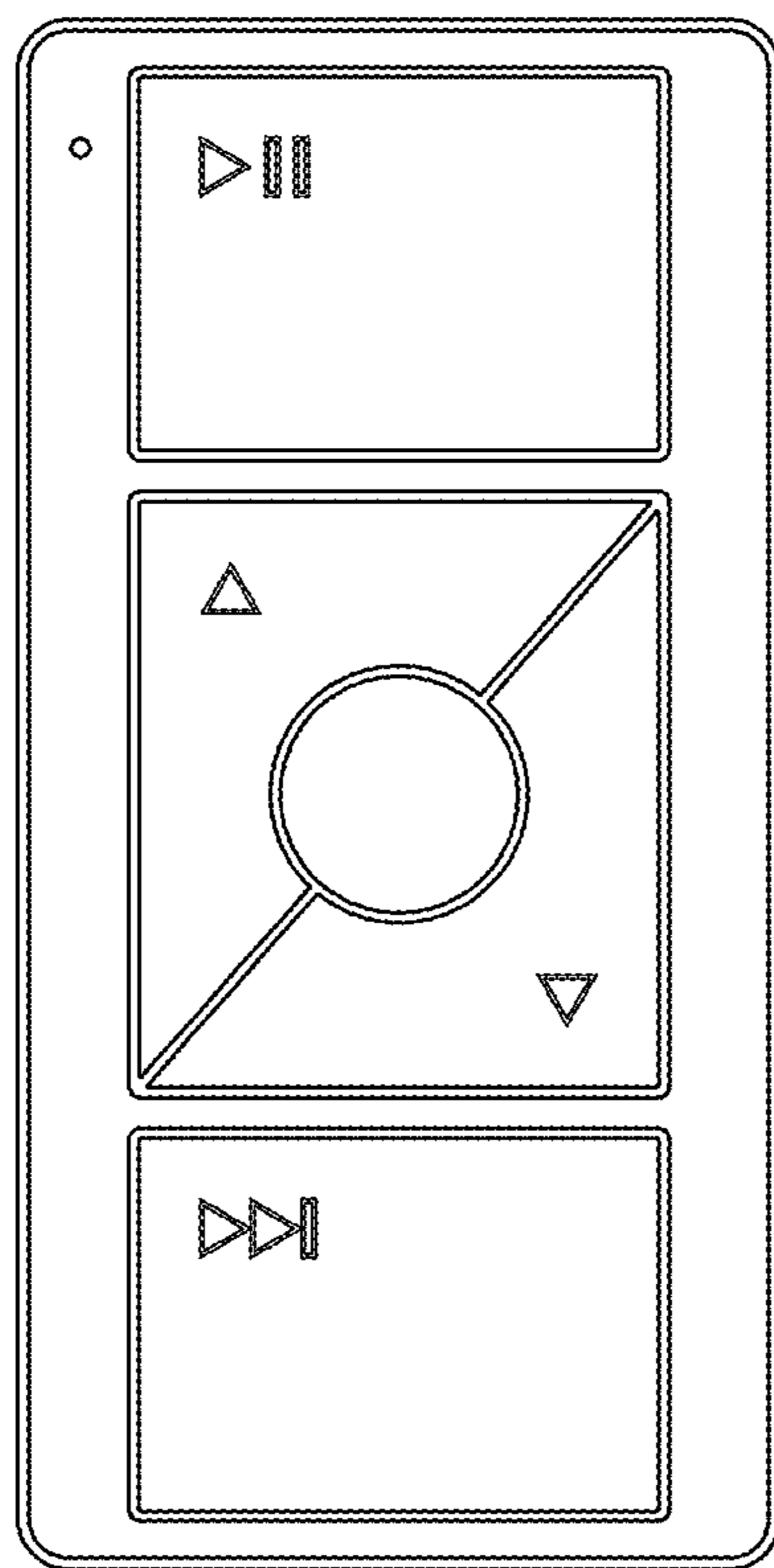

Fig. 2

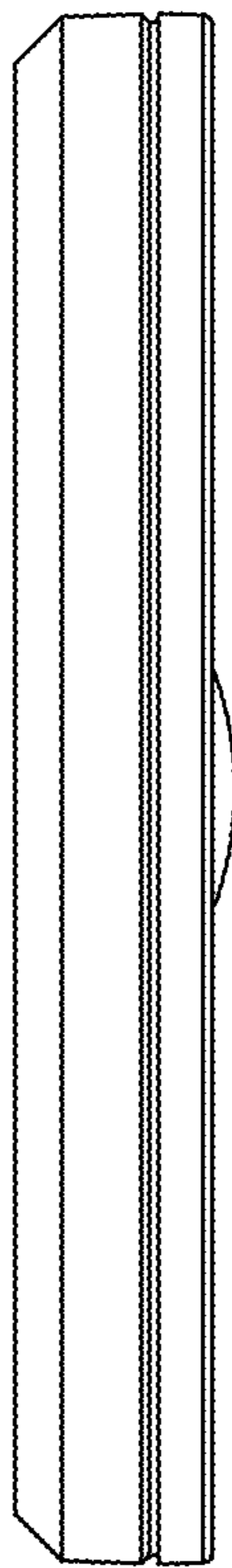

Fig. 3

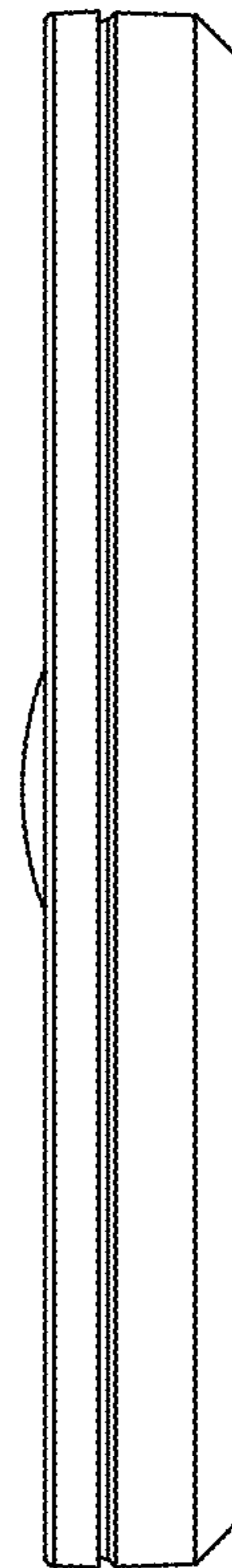

Fig. 4

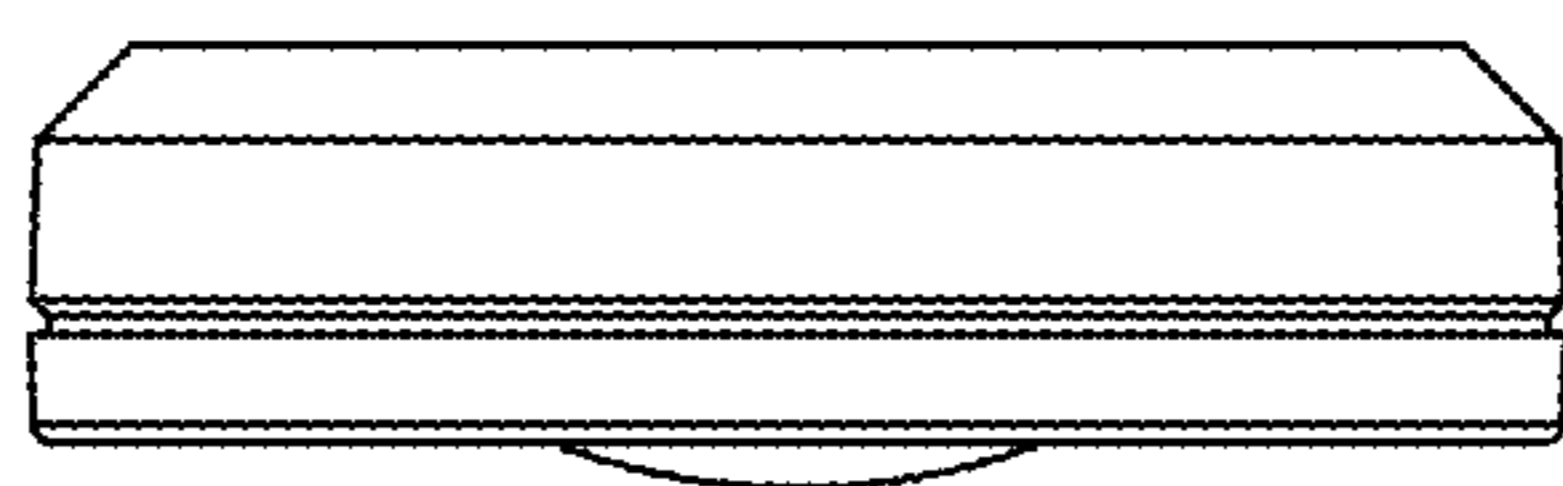

Fig. 5

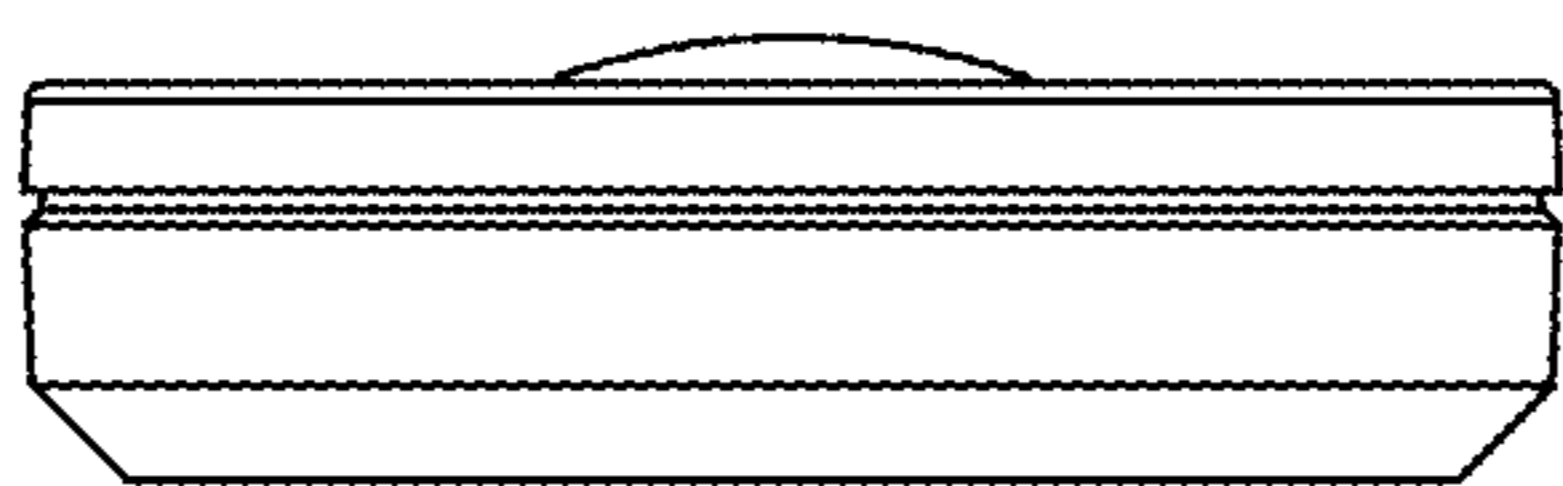

Fig. 6

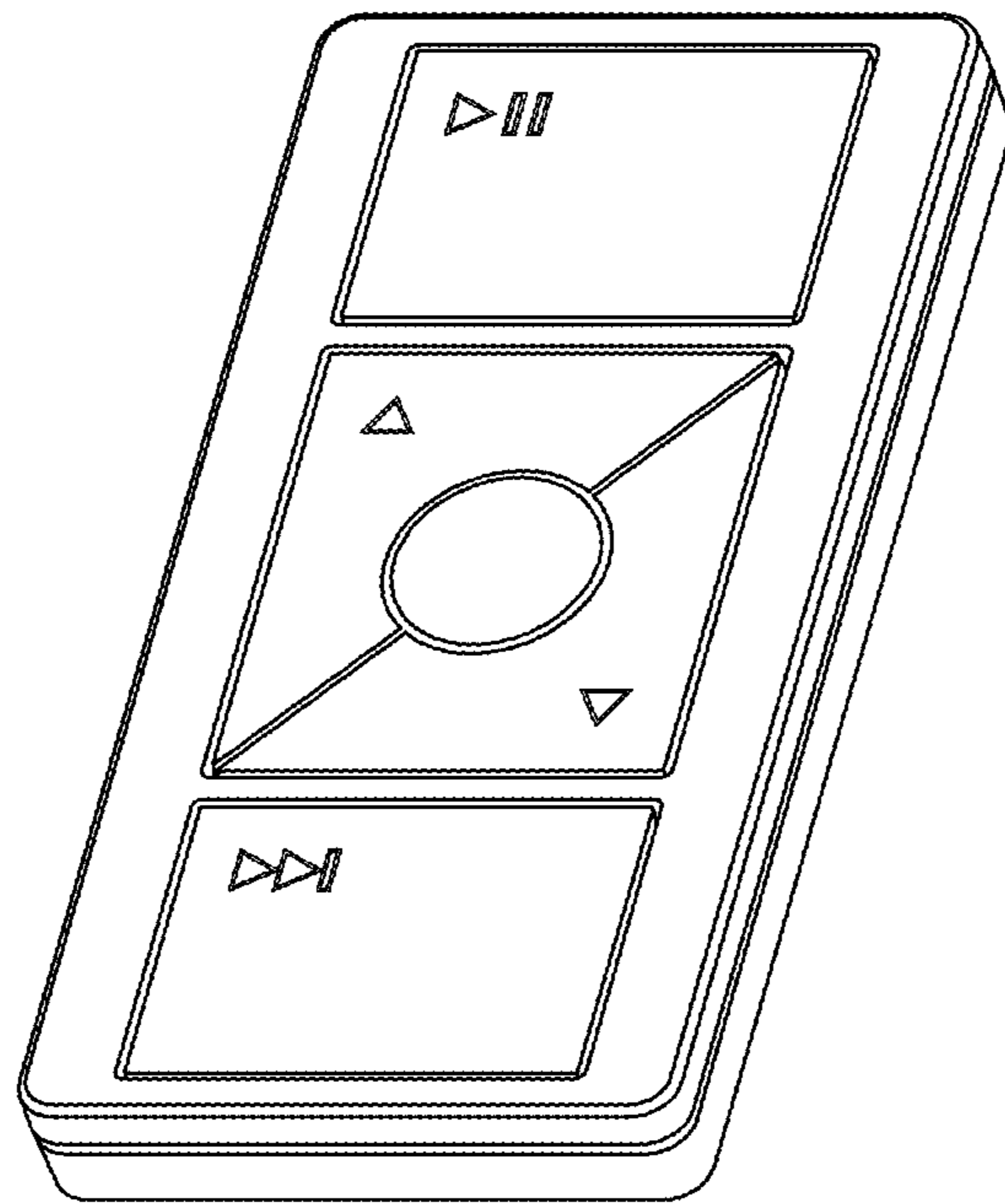

Fig. 7

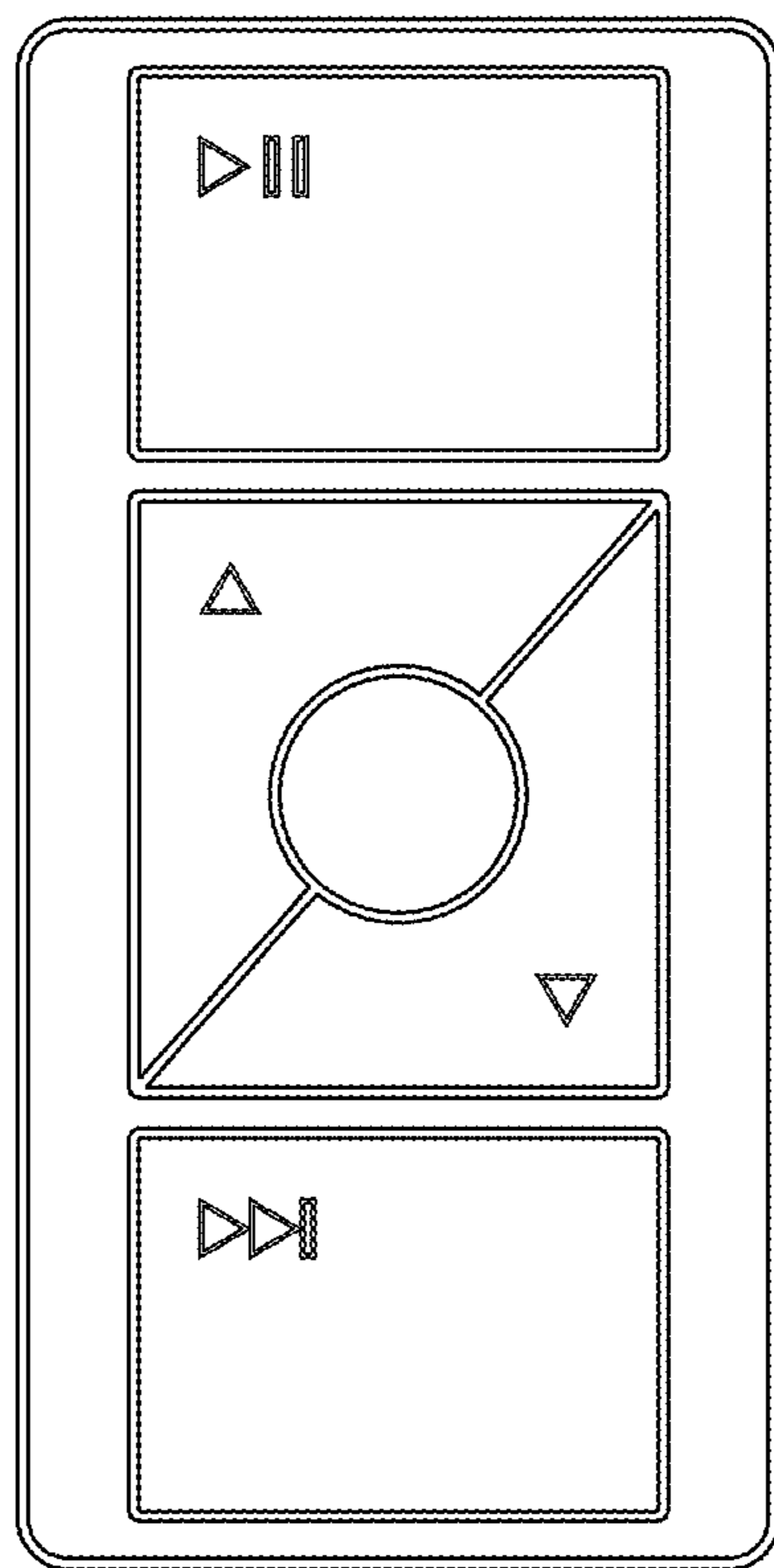

Fig. 8

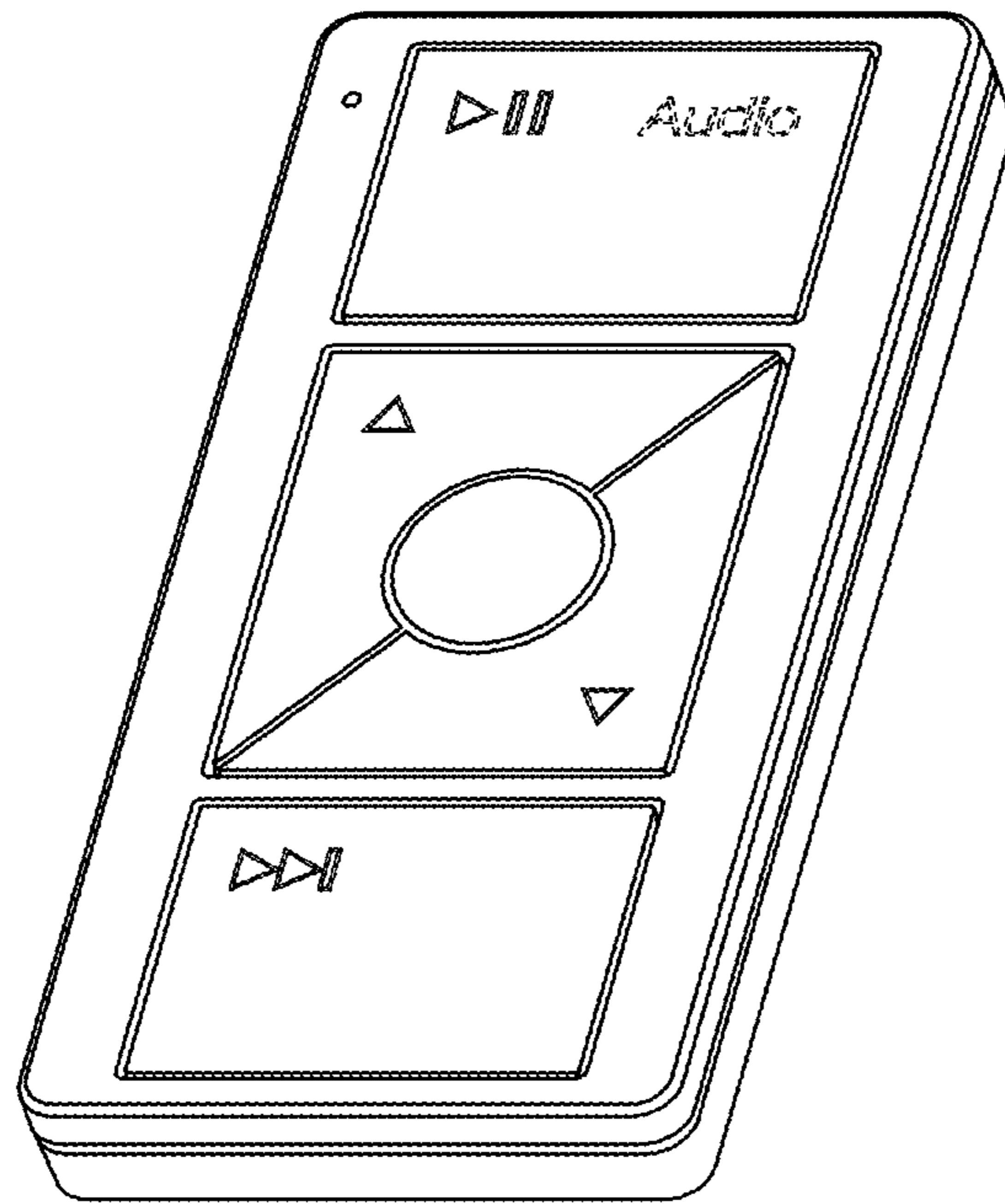

Fig. 9

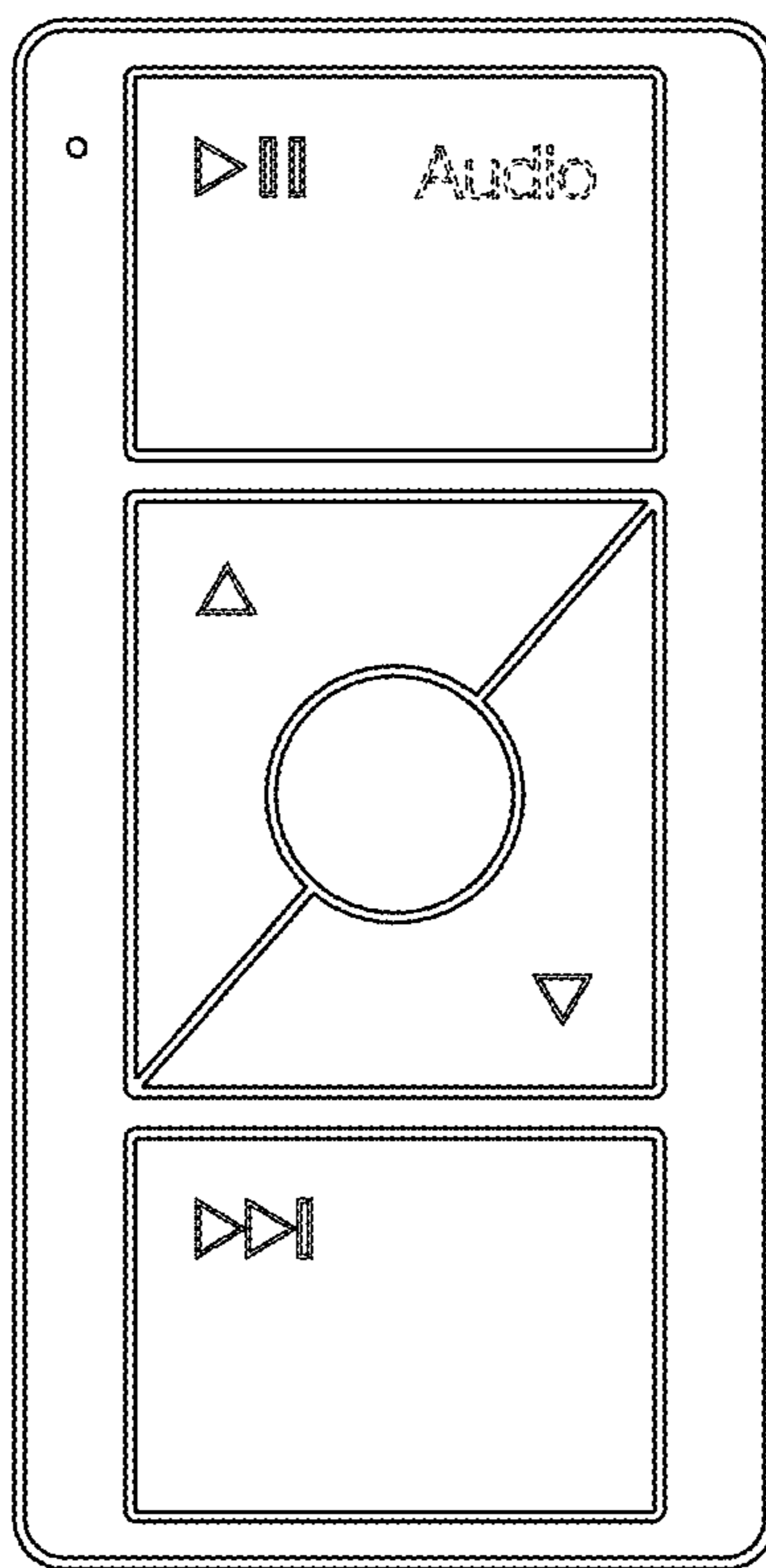

Fig. 10

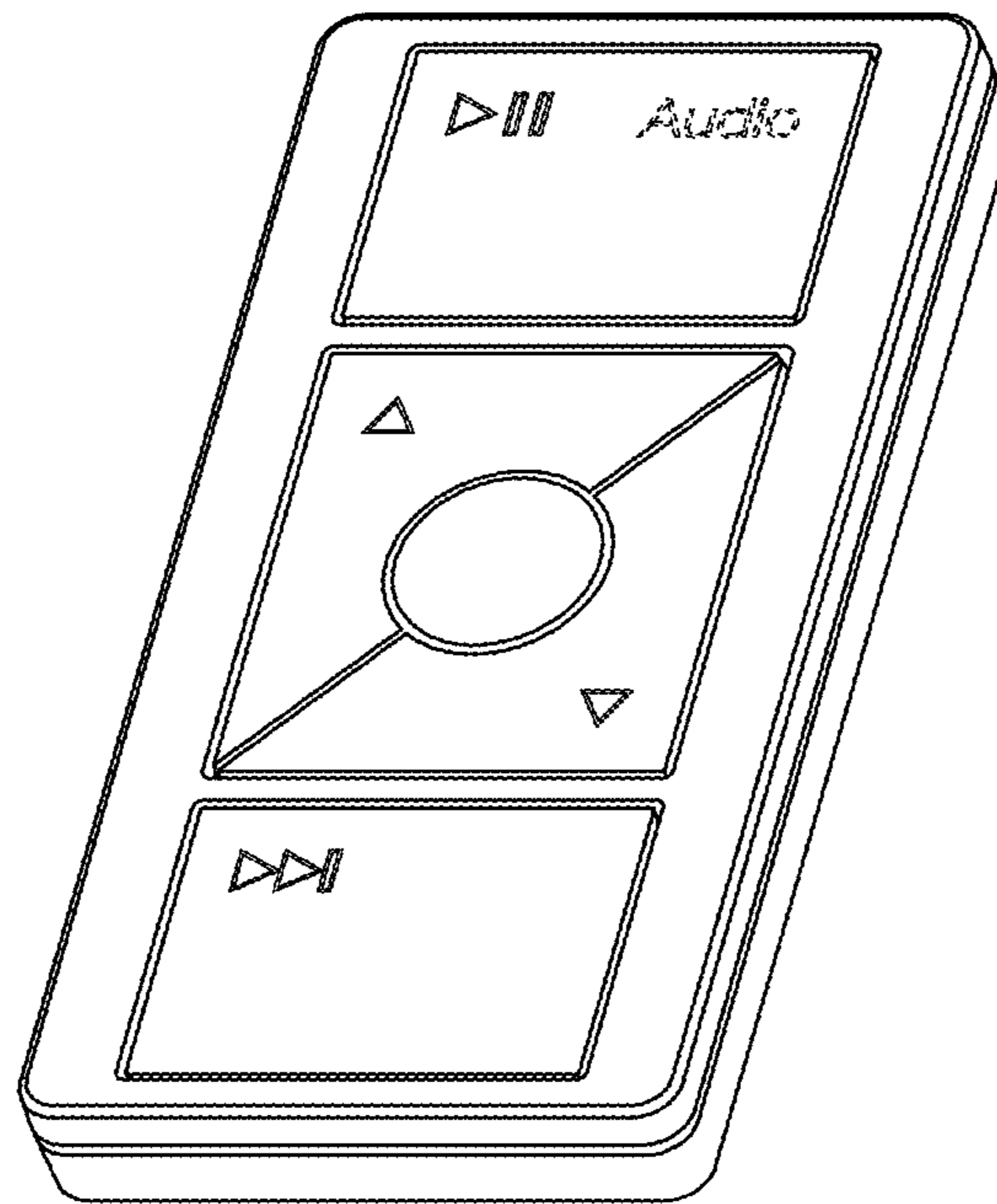

Fig. 11

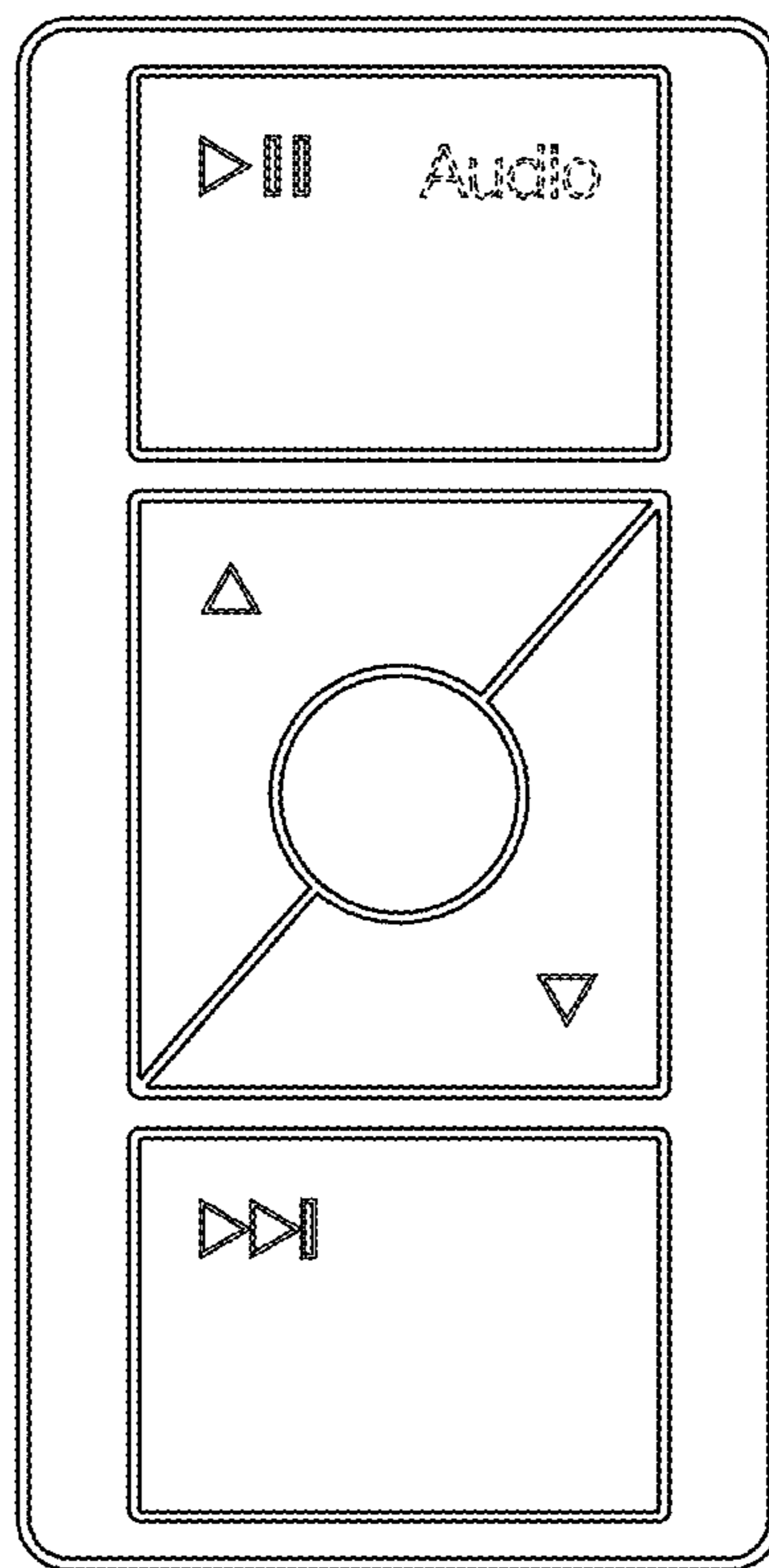

Fig. 12

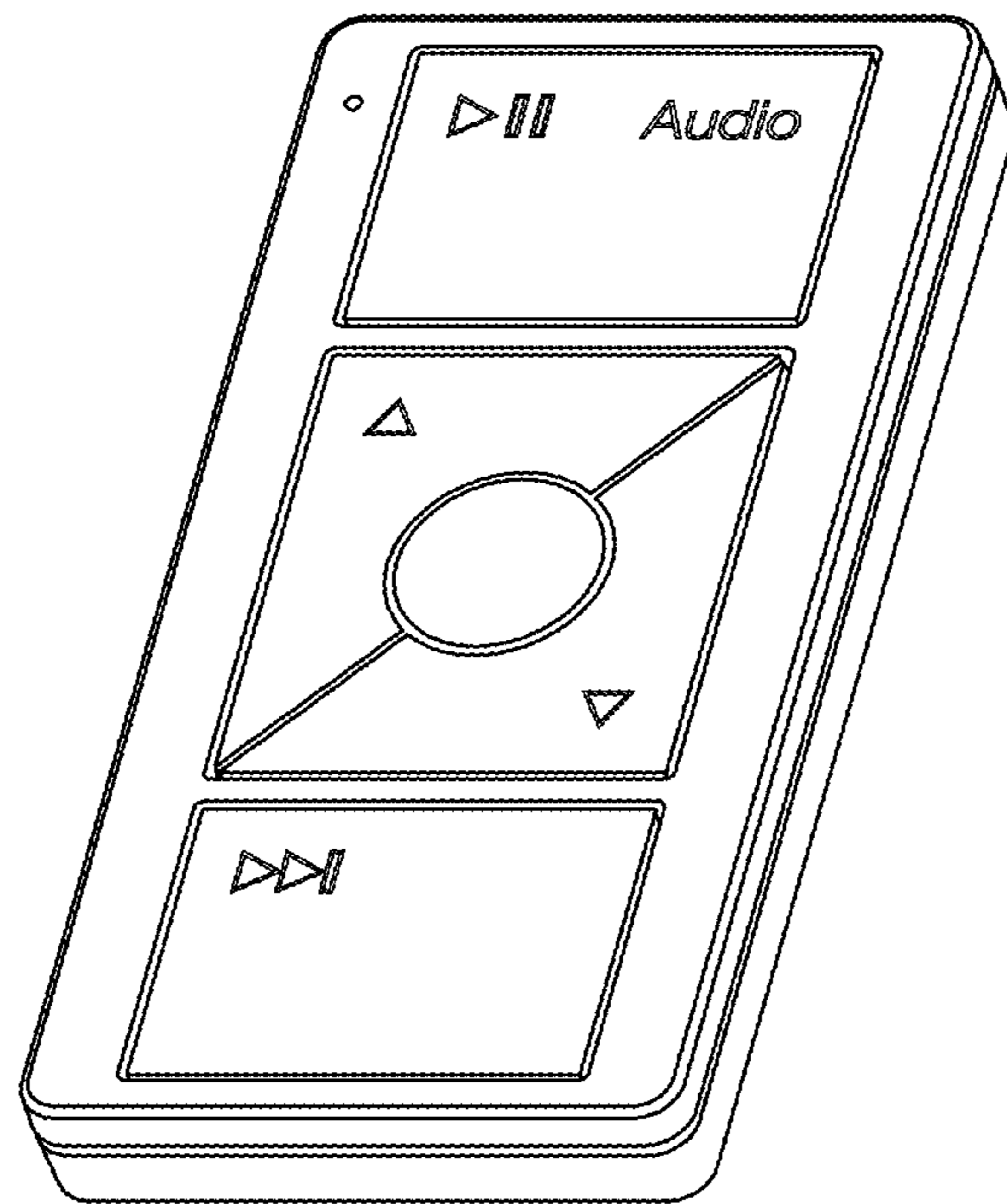

Fig. 13

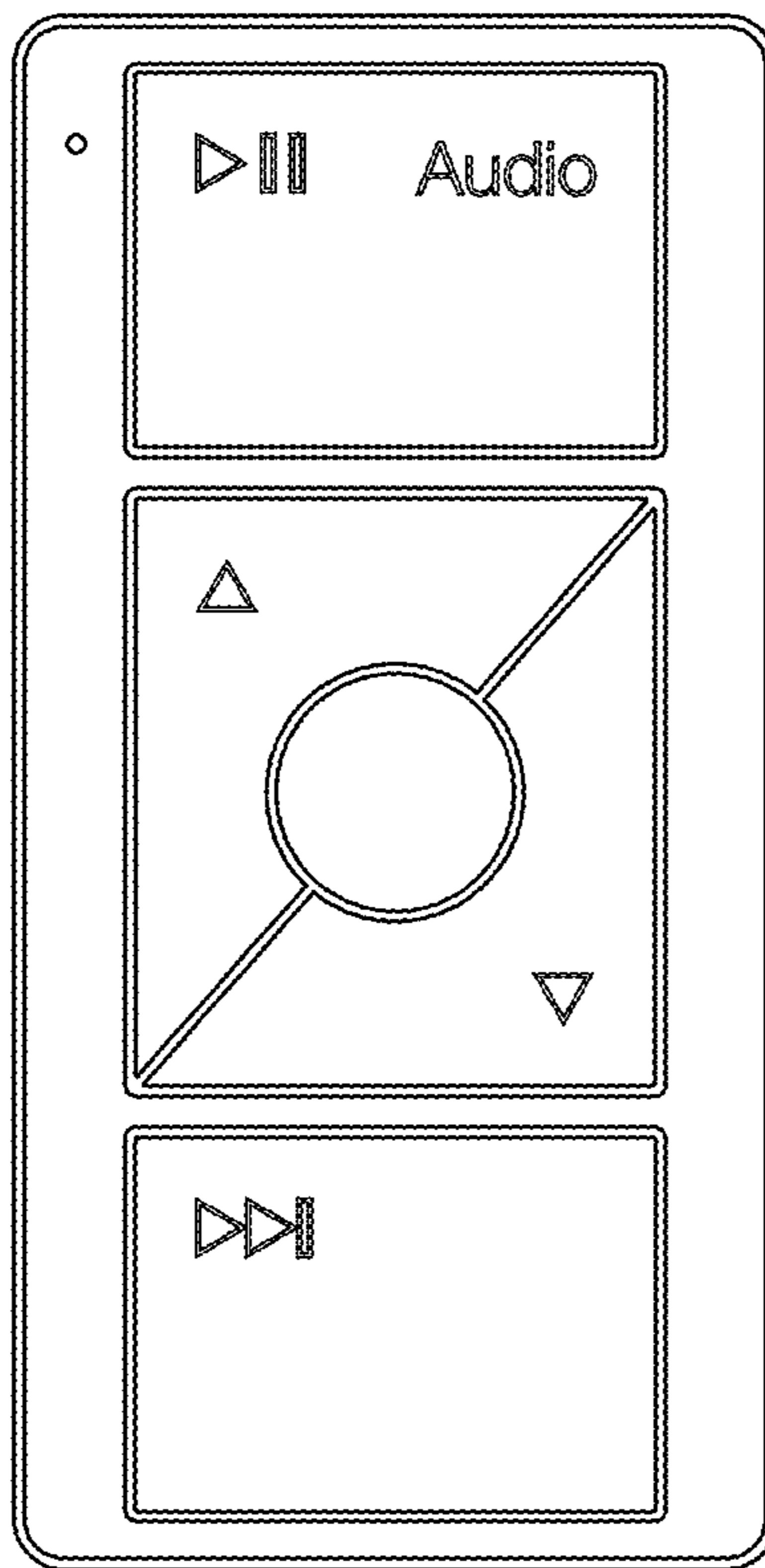

Fig. 14

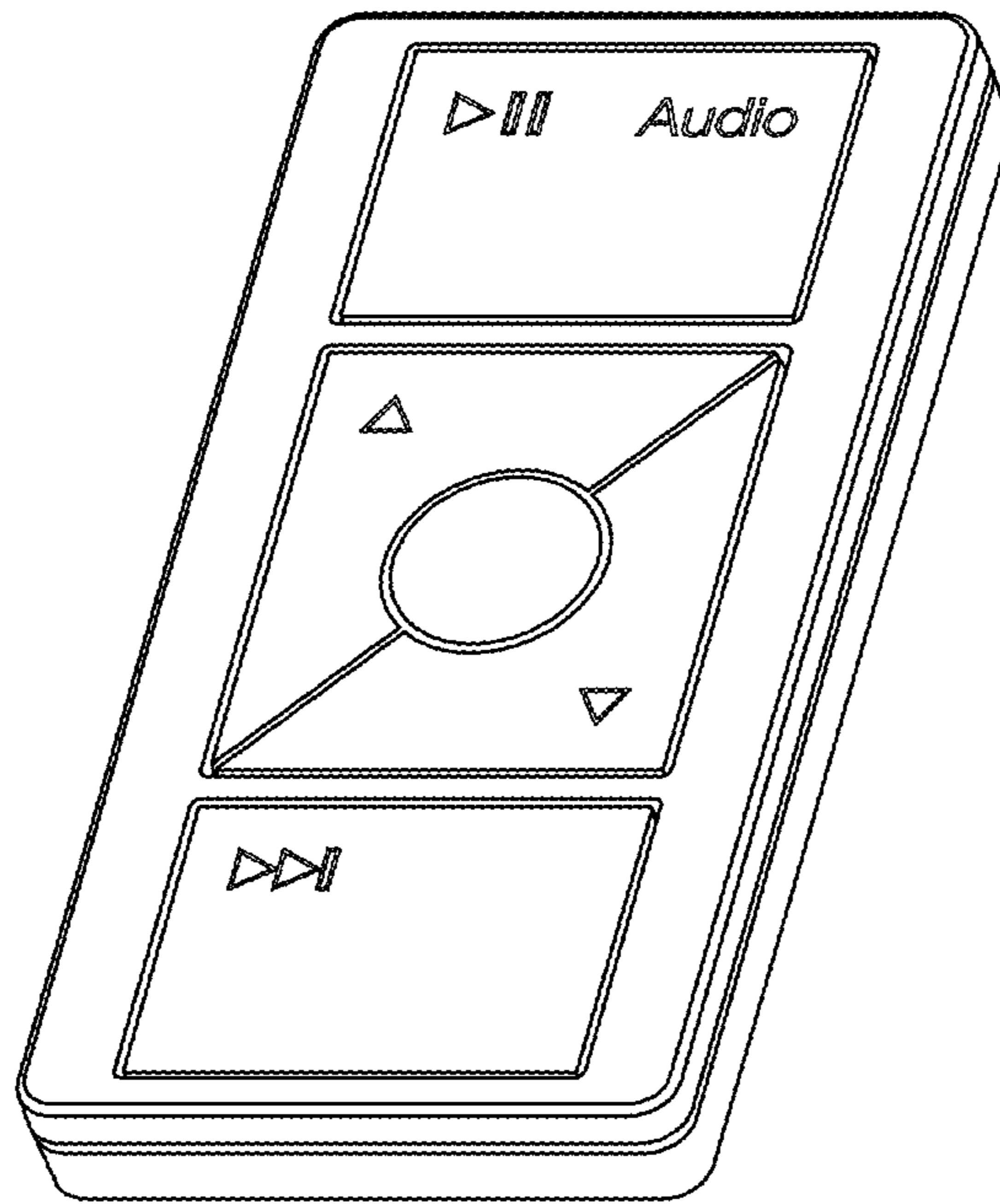

Fig. 15

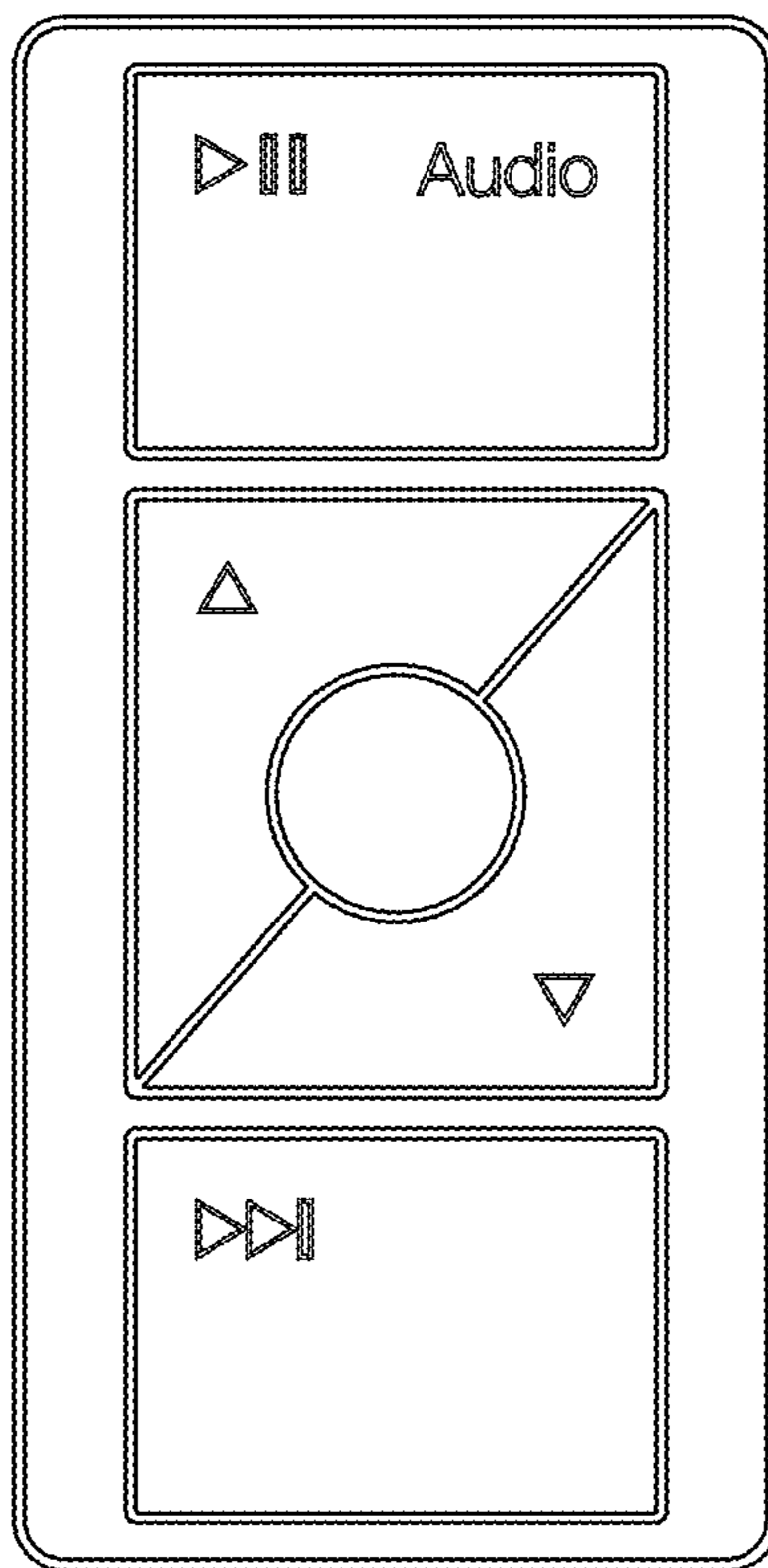

Fig. 16

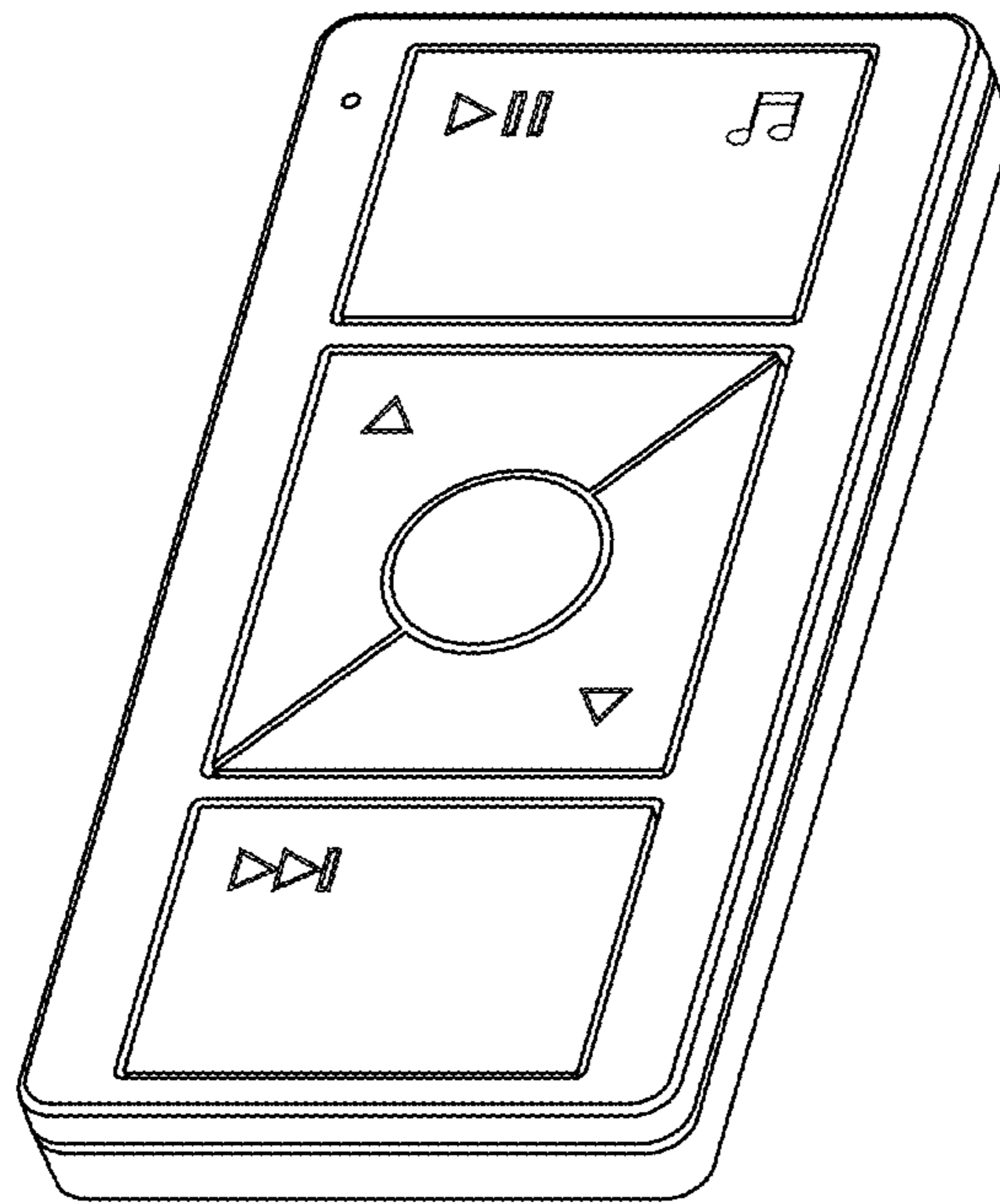

Fig. 17

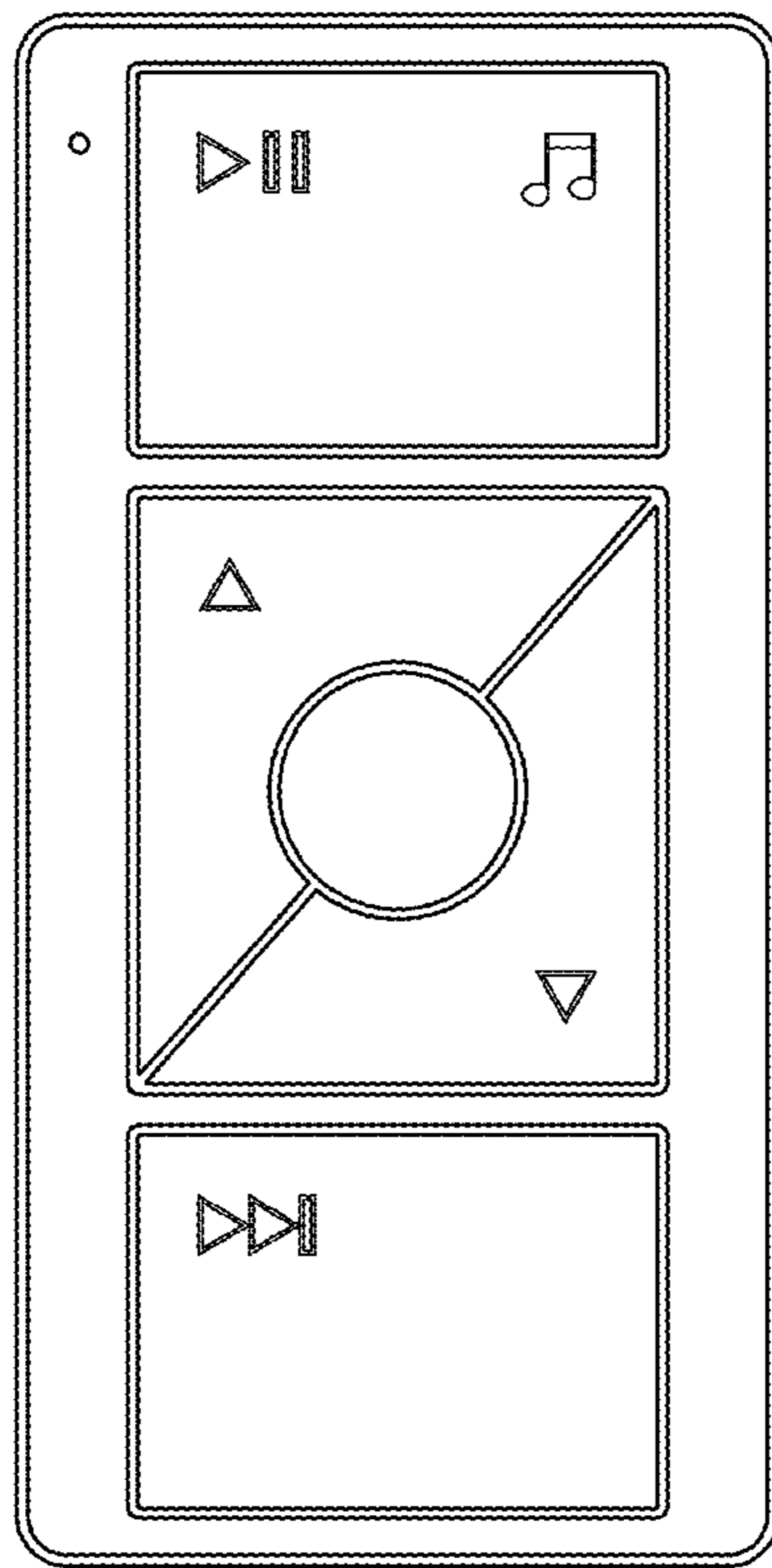

Fig. 18

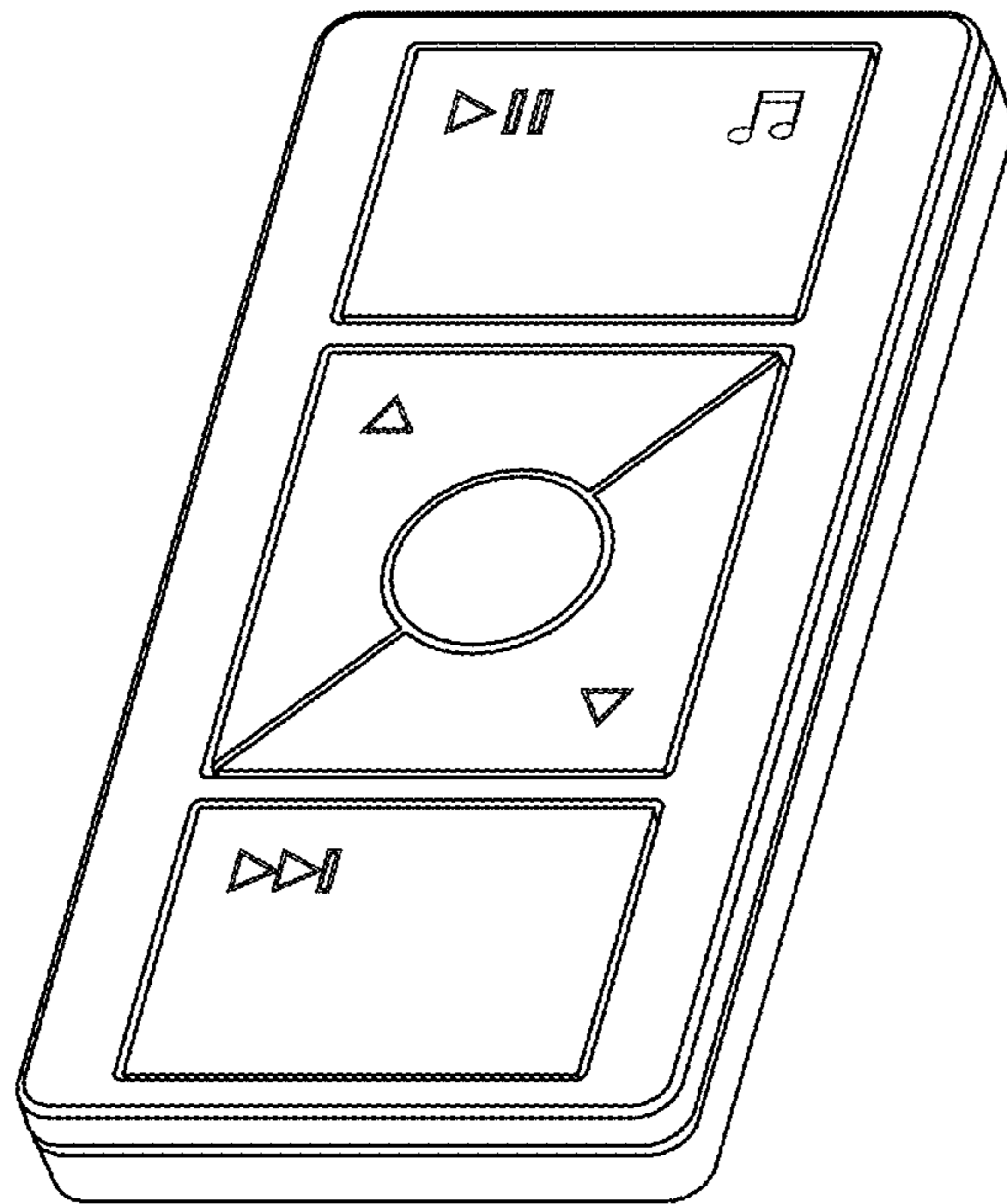

Fig. 19

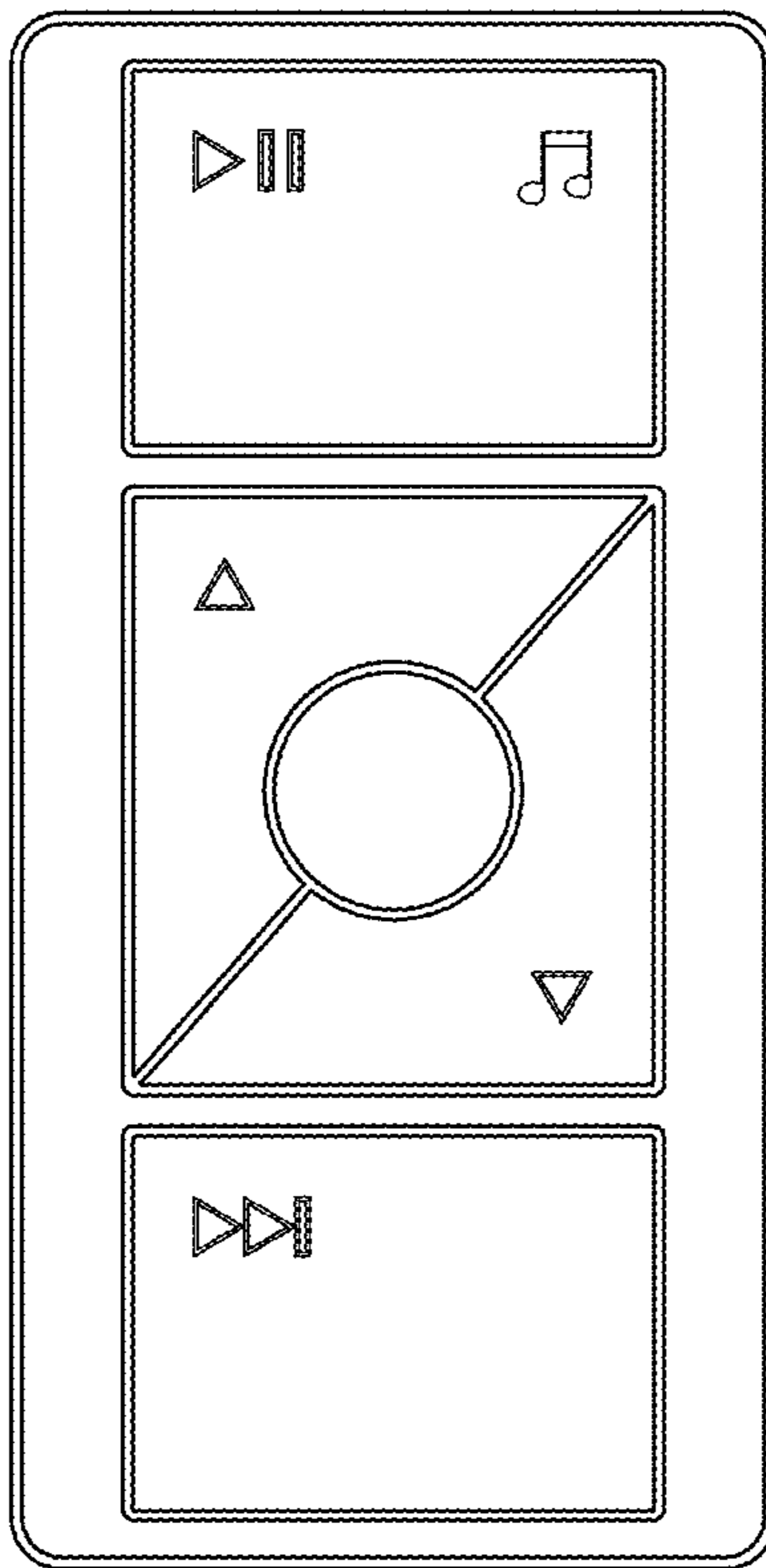

Fig. 20