



US00D862321S

(12) **United States Design Patent** (10) **Patent No.:** **US D862,321 S**  
**Duncan et al.** (45) **Date of Patent:** **\*\* Oct. 8, 2019**

(54) **TRUCK HOOD UNIT**  
(71) Applicants: **Jonathan S. Duncan**, Seattle, WA (US); **Steven H. Hovind**, Renton, WA (US); **Scott D. Hite**, Pilot Point, TX (US); **Brent Johnson**, Denton, TX (US); **Tu H. Do**, Lewisville, TX (US); **Troy R. McCuller**, Corinth, TX (US)  
(72) Inventors: **Jonathan S. Duncan**, Seattle, WA (US); **Steven H. Hovind**, Renton, WA (US); **Scott D. Hite**, Pilot Point, TX (US); **Brent Johnson**, Denton, TX (US); **Tu H. Do**, Lewisville, TX (US); **Troy R. McCuller**, Corinth, TX (US)  
(73) Assignee: **PACCAR Inc**, Bellevue, WA (US)  
(\*\*) Term: **15 Years**  
(21) Appl. No.: **29/630,168**  
(22) Filed: **Dec. 19, 2017**  
(51) **LOC (12) Cl.** ..... **12-16**  
(52) **U.S. Cl.**  
USPC ..... **D12/173**  
(58) **Field of Classification Search**  
USPC ..... D12/173, 196, 86, 90-92, 181;  
180/69.21, 69.2, 69.22; 296/190.1-190.5,  
296/190.8, 193.11, 37.6  
CPC ..... B62D 25/10; B62D 25/06; B62D 65/02;  
B62D 25/12; B60Q 1/00  
See application file for complete search history.

D382,239 S 8/1997 Logan et al.  
D382,841 S 8/1997 Norwood et al.  
D382,844 S 8/1997 Norwood et al.  
D395,860 S 7/1998 Meryman et al.  
D401,198 S 11/1998 Mueller et al.  
D403,636 S 1/1999 Meryman et al.  
D403,639 S 1/1999 Gale et al.  
D411,494 S 6/1999 Meryman et al.  
D412,689 S 8/1999 Onopa  
D422,251 S 4/2000 Bader et al.  
D431,806 S 10/2000 Damon et al.  
D433,980 S 11/2000 Conway et al.  
D434,358 S 11/2000 Conway et al.

(Continued)

**OTHER PUBLICATIONS**

“T440,” Kenworth Truck Company, Kirkland, Washington, 2010, 2-page brochure.

(Continued)

*Primary Examiner* — Melody N Brown  
(74) *Attorney, Agent, or Firm* — Christensen O’Connor Johnson Kindness PLLC

(57) **CLAIM**

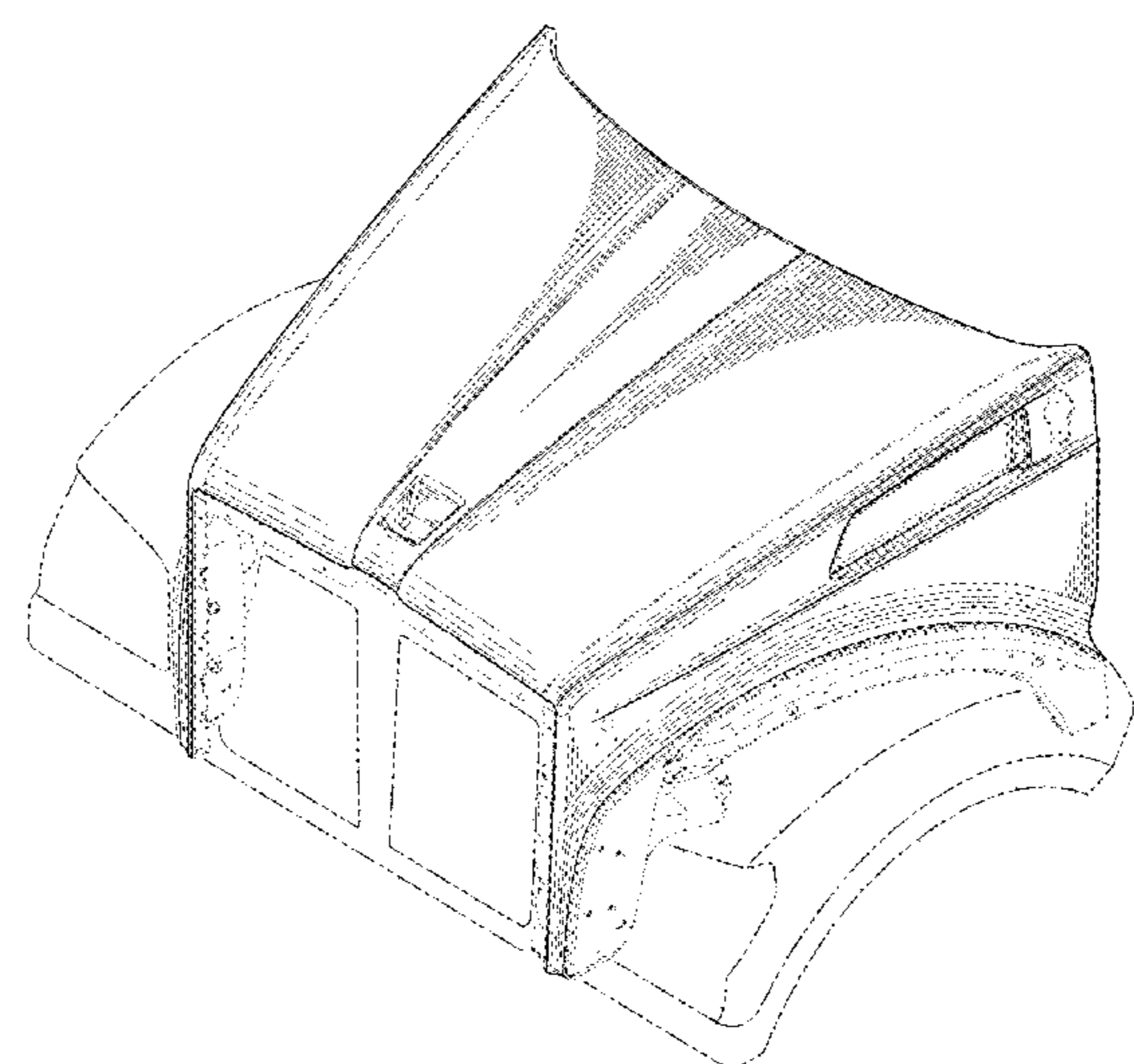
The ornamental design for a truck hood unit, as shown and described.

**DESCRIPTION**

FIG. 1 is a perspective view of a truck hood unit showing our new design;  
FIG. 2 is another perspective view thereof;  
FIG. 3 is a top plan view thereof;  
FIG. 4 is a front elevational view thereof;  
FIG. 5 is a left side elevational view thereof; and,  
FIG. 6 is a right side elevational view thereof.  
The portions of the truck hood unit shown in broken lines in the FIG. 2 drawing view is for environmental and illustrative purposes and form no part of the claimed design.

**1 Claim, 6 Drawing Sheets**

(56) **References Cited**  
U.S. PATENT DOCUMENTS  
D50,345 S 2/1917 Green  
D50,346 S 2/1917 Green  
D366,638 S 1/1996 Tucker et al.  
D366,640 S 1/1996 Tucker et al.  
D378,812 S 4/1997 Aycock



(56)

References Cited

U.S. PATENT DOCUMENTS

D435,816 S 1/2001 Delashaw et al.  
 D436,563 S 1/2001 Delashaw et al.  
 D443,853 S 6/2001 Barraclough et al.  
 D446,175 S 8/2001 Hoyle, Jr.  
 D450,277 S 11/2001 Onopa  
 D460,023 S 7/2002 Beigel  
 D465,749 S 11/2002 Beigel  
 D466,450 S 12/2002 Maher et al.  
 D478,300 S 8/2003 Chiang  
 D482,993 S 12/2003 Conway et al.  
 D484,077 S 12/2003 Conway et al.  
 D488,112 S 4/2004 Satou  
 D490,749 S 6/2004 Satou et al.  
 D491,858 S 6/2004 Velazco  
 D492,921 S 7/2004 Perfetti et al.  
 D494,900 S 8/2004 Satou  
 D495,633 S 9/2004 Chiang  
 D497,581 S 10/2004 Conway et al.  
 D502,901 S 3/2005 Delashaw et al.  
 D502,904 S 3/2005 Delashaw et al.  
 D504,642 S 5/2005 Perfetti et al.  
 D511,727 S 11/2005 Shaw et al.  
 D512,666 S 12/2005 Chiang  
 D514,483 S 2/2006 Chiang  
 D517,965 S 3/2006 Metros et al.  
 D518,761 S 4/2006 Chiang  
 D523,793 S 6/2006 Beigel et al.  
 D524,204 S 7/2006 Beigel  
 D531,947 S 11/2006 Angelo et al.  
 D532,350 S 11/2006 Angelo et al.  
 D532,352 S 11/2006 Angelo et al.  
 D540,725 S 4/2007 Gunter et al.  
 D540,727 S 4/2007 Elliott et al.  
 D545,250 S \* 6/2007 Angelo ..... D12/173  
 D545,251 S \* 6/2007 Angelo ..... D12/173  
 D545,254 S 6/2007 Angelo et al.  
 D545,255 S 6/2007 Angelo et al.  
 D545,735 S \* 7/2007 Angelo ..... D12/173  
 D560,575 S 1/2008 Simons et al.  
 D560,582 S 1/2008 Simons et al.  
 D560,583 S 1/2008 Simons et al.  
 D561,647 S \* 2/2008 Simons ..... D12/173  
 D563,281 S 3/2008 Simons et al.  
 D563,849 S 3/2008 Medina et al.  
 D563,850 S 3/2008 Rosen et al.  
 D563,851 S 3/2008 Rosen et al.  
 D563,852 S 3/2008 Rosen et al.  
 D563,853 S 3/2008 Rosen et al.  
 D564,427 S 3/2008 Beigel et al.  
 D566,635 S 4/2008 Rosen et al.  
 D571,696 S 6/2008 Rosen et al.  
 D578,453 S 10/2008 Raghavendran et al.  
 D588,512 S 3/2009 Raghavendran et al.  
 D592,574 S 5/2009 Larson  
 D597,003 S 7/2009 Yamazaki et al.  
 D605,986 S 12/2009 Raghavendran et al.  
 D619,941 S 7/2010 Krauss  
 D621,754 S 8/2010 Angelo et al.  
 D622,188 S 8/2010 Angelo et al.  
 D632,224 S \* 2/2011 Peltola ..... D12/173  
 D632,234 S 2/2011 Peltola et al.  
 D643,352 S 8/2011 Hjorten et al.  
 D647,016 S 10/2011 Medina et al.  
 D647,832 S 11/2011 Medina et al.  
 D654,401 S 2/2012 Peltola et al.  
 D654,417 S 2/2012 Peltola et al.  
 D685,294 S 7/2013 Hanson et al.  
 D686,122 S \* 7/2013 Peltola ..... D12/173  
 D690,242 S 9/2013 Conway et al.  
 D690,632 S 10/2013 Peltola et al.  
 D699,650 S 2/2014 Peltola et al.  
 D699,651 S 2/2014 Peltola et al.  
 D702,609 S 4/2014 Hovind et al.  
 D702,615 S 4/2014 Conway et al.  
 D706,690 S 6/2014 Peltola et al.

D707,160 S 6/2014 Peltola et al.  
 D707,161 S 6/2014 Peltola et al.  
 D707,163 S 6/2014 Peltola et al.  
 D708,104 S 7/2014 Conway et al.  
 D708,553 S 7/2014 Conway et al.  
 D708,985 S 7/2014 Peltola et al.  
 D708,986 S 7/2014 Conway et al.  
 D708,989 S 7/2014 Peltola et al.  
 D708,990 S 7/2014 Conway et al.  
 D708,999 S \* 7/2014 Conway ..... D12/173  
 D709,000 S \* 7/2014 Peltola ..... D12/173  
 D709,001 S 7/2014 Conway et al.  
 D709,406 S 7/2014 Conway et al.  
 D709,407 S 7/2014 Conway et al.  
 D709,408 S 7/2014 Peltola et al.  
 D709,410 S 7/2014 Conway et al.  
 D709,411 S 7/2014 Peltola et al.  
 D709,421 S 7/2014 Conway et al.  
 D709,422 S 7/2014 Peltola et al.  
 D709,423 S 7/2014 Peltola et al.  
 D709,424 S 7/2014 Conway et al.  
 D709,425 S 7/2014 Conway et al.  
 D710,765 S 8/2014 Conway et al.  
 D714,195 S 9/2014 Conway et al.  
 D718,682 S \* 12/2014 McFarlin ..... D12/173  
 D722,934 S 2/2015 Conway et al.  
 D729,709 S \* 5/2015 Conway ..... D12/173  
 D743,308 S \* 11/2015 Hanson ..... D12/173  
 D746,200 S 12/2015 Leetz  
 D756,855 S 5/2016 Leetz et al.  
 D770,335 S 11/2016 Walterscheid et al.  
 D778,217 S \* 2/2017 Ito ..... D12/173  
 D782,381 S 3/2017 Conway et al.  
 D805,981 S 12/2017 Conway et al.  
 2013/0025954 A1 1/2013 Miller et al.

OTHER PUBLICATIONS

“T440,” Kenworth Truck Company, Kirkland, Washington, 2010, 6-page brochure.  
 “T470,” Kenworth Truck Company, Kirkland, Washington, 2010, 6-page brochure.  
 “T470H,” Kenworth Truck Company, Kirkland, Washington, 2009, 2-page brochure.  
 “T600,” Kenworth Truck Company, Kirkland, Washington, 1996, 7-page brochure.  
 “T600,” Kenworth Truck Company, Kirkland, Washington, 2002, 28-page brochure.  
 “T600,” Kenworth Truck Company, Kirkland, Washington, 2005, 24-page brochure.  
 “T600A,” Kenworth Truck Company, Kirkland, Washington, 1985, 10-page brochure.  
 “T660,” Kenworth Truck Company, Kirkland, Washington, 2007, 36-page brochure.  
 “T660,” Kenworth Truck Company, Kirkland, Washington, 2009, 36-page brochure.  
 “T700,” Kenworth Truck Company, Kirkland, Washington, 2010, 6-page brochure.  
 “T800,” Kenworth Truck Company, Kirkland, Washington, 1996, 7-page brochure.  
 “T800,” Kenworth Truck Company, Kirkland, Washington, 2002, 32-page brochure.  
 “T800,” Kenworth Truck Company, Kirkland, Washington, 2003, 32-page brochure.  
 “T800,” Kenworth Truck Company, Kirkland, Washington, 2005, 28-page brochure.  
 “T800,” Kenworth Truck Company, Kirkland, Washington, 2009, 28-page brochure.  
 “T800B,” Kenworth Truck Company, Kirkland, Washington, 1993, 8-page brochure.  
 “The Working Class,” Peterbilt Motors Company, Newark, California, Sep. 1976, 6-page brochure.  
 “The World’s Best,” Kenworth Truck Company, Kirkland, Washington, 1992, 12-page brochure.

(56)

**References Cited**

## OTHER PUBLICATIONS

"Unibilt™ Cab Sleeper System," Peterbilt Motors Company, Denton Texas, Aug. 1994, 6-page brochure.

"W900," Kenworth Truck Company, Kirkland, Washington, 1996, 7-page brochure.

"W900," Kenworth Truck Company, Kirkland, Washington, 2002, 32-page brochure.

"W900," Kenworth Truck Company, Kirkland, Washington, 2005, 28-page brochure.

"W900," Kenworth Truck Company, Kirkland, Washington, 2009, 28-page brochure.

"W900L Aero Cab," Kenworth Truck Company, Kirkland, Washington, 1994, 2-page brochure.

"AeroCab," Kenworth Truck Company, Kirkland, Washington, 1993, 5-page brochure.

"AeroCab," Kenworth Truck Company, Kirkland, Washington, as early as 1995, 3-page brochure.

"C500B," Kenworth Truck Company, Kirkland, Washington, as early as 1990, 4-page brochure.

"Class Pays, Medium Duty," Peterbilt Motors Company, Denton, Texas, Sep. 2000, 12-page brochure.

"Class Pays, Truck Models," Peterbilt Motors Company, Denton, Texas, Mar. 2005, 24-page brochure.

"Class Pays," Peterbilt Motors Company, Denton, Texas, Nov. 1998, 10-page brochure.

Class Pays, Peterbilt Motors Company, Denton, Texas, Sep. 1997, 10-page brochure.

Class Pays, Construction Trucks, Peterbilt Motors Company, Denton, Texas, Nov. 2003, 16-page brochure.

"Kenworth Truck Models," Kenworth Truck Company, Kirkland, Washington, 2010, 16-page brochure.

"Model 330," Peterbilt Motors Company, Denton, Texas, Oct. 1997, 3-page brochure.

"Model 357 Heavy Haul," Peterbilt Motors Company, Denton, Texas, Mar. 2005, 2-page brochure.

"Model 357 Standard Specifications," Peterbilt Motors Company, Newark, California, Sep. 1986, 6-page brochure.

"Model 357, New Sloped Hood," Peterbilt Motors Company, Denton, Texas, May 2002, 2-page brochure.

"Model 357," Peterbilt Motors Company, Denton, Texas, May 1994, 3-page brochure.

"Model 357-115," Peterbilt Motors Company, Denton, Texas, Mar. 2005, 2-page brochure.

"Model 375 Standard Specifications," Peterbilt Motors Company, Newark, California, Sep. 1986, 6-page brochure.

"Model 377A/E," Peterbilt Motors Company, Denton, Texas, Aug. 1997, 2-page brochure.

"Model 377A/E," Peterbilt Motors Company, Denton, Texas, Jan. 1995, 6-page brochure.

"Model 378," Peterbilt Motors Company, Denton, Texas, Mar. 1998, 3-page brochure.

"Model 379," Peterbilt Motors Company, Denton, Texas, Apr. 2005, 2-page brochure.

"Model 379," Peterbilt Motors Company, Denton, Texas, Mar. 1996, 5-page brochure.

"Model 385," Peterbilt Motors Company, Denton, Texas, Oct. 1996, 5-page brochure.

"Model 387," Peterbilt Motors Company, Denton, Texas, Oct. 2002, 2-page brochure.

"Rest with Class," Peterbilt Motors Company, Newark, California, Apr. 1978, 4-page brochure.

"T170 Class 5," Kenworth Truck Company, Kirkland, Washington, 2008, 4-page brochure.

"T2000," Kenworth Truck Company, Kirkland, Washington, 1999, 20-page brochure.

"T2000," Kenworth Truck Company, Kirkland, Washington, 2002, 20-page brochure.

"T2000," Kenworth Truck Company, Kirkland, Washington, 2005, 20-page brochure.

"T270 Class 6 and T370 Class 7," Kenworth Truck Company, Kirkland, Washington, 2008, 6-page brochure.

"T270 Class 6 and T370 Class 7," Kenworth Truck Company, Kirkland, Washington, 2009, 6-page brochure.

"T270 Class 6 and T370 Class 7 Hybrid," Kenworth Truck Company, Kirkland, Washington, 2009, 6-page brochure.

"T300," Kenworth Truck Company, Kirkland, Washington, 1994, 4-page brochure.

"T300," Kenworth Truck Company, Kirkland, Washington, 2001, 16-page brochure.

"T300," Kenworth Truck Company, Kirkland, Washington, 2005, 16-page brochure.

"T680," Kenworth Truck Company, Kirkland, Washington, 2013, 34-page brochure.

"T680," Kenworth Truck Company, Kirkland, Washington, 2016, 34-page brochure.

"T880," Kenworth Truck Company, Kirkland, Washington, 2017, 32-page brochure.

"Model 579," Peterbilt Motors Company, Denton, Texas, 2013, 13-page brochure.

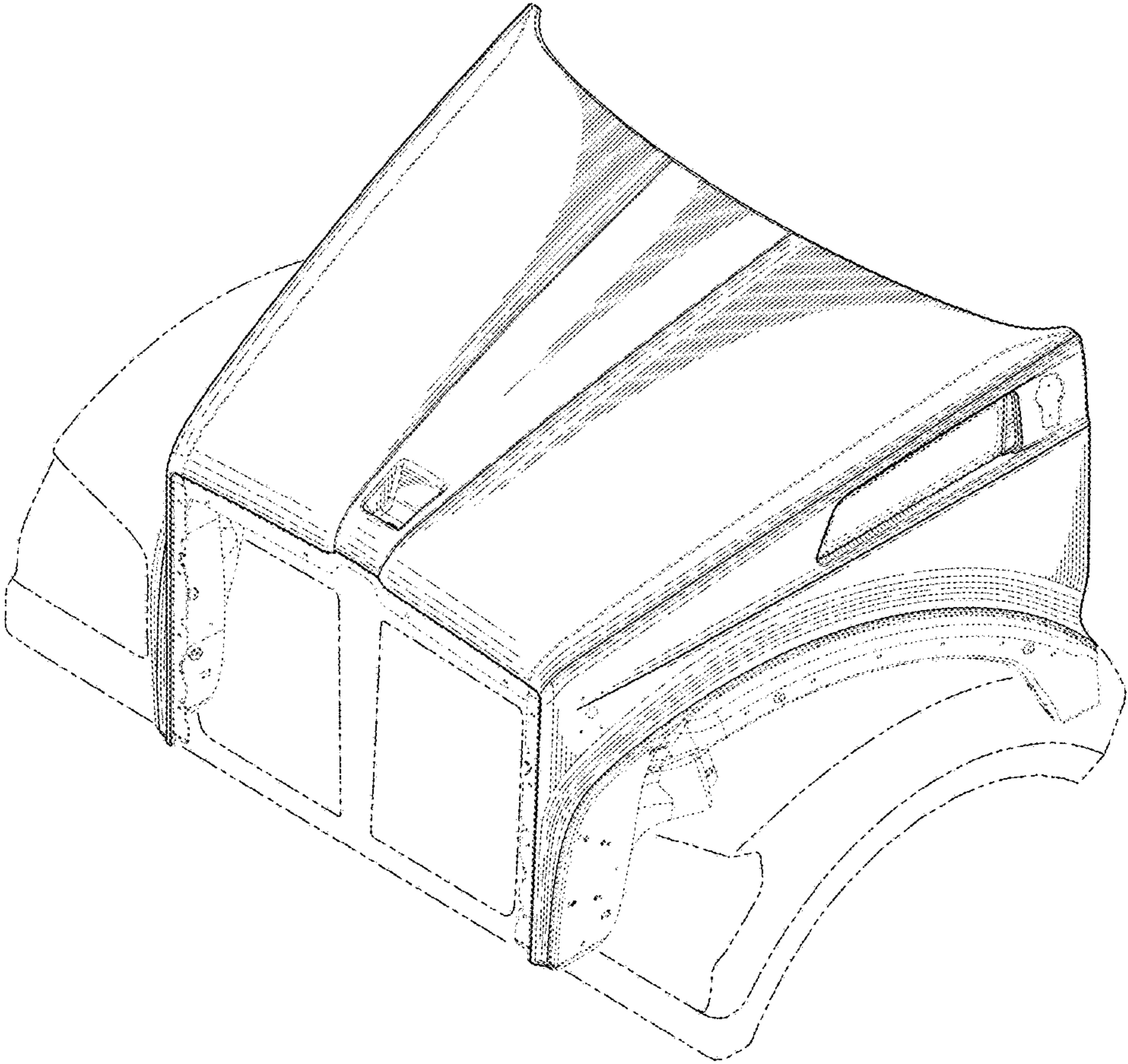
"Model 587," Peterbilt Motors Company, Denton, Texas, 2011, 4-page brochure.

"Medium-Duty," Peterbilt Motors Company, Denton, Texas, 2013, 9-page brochure.

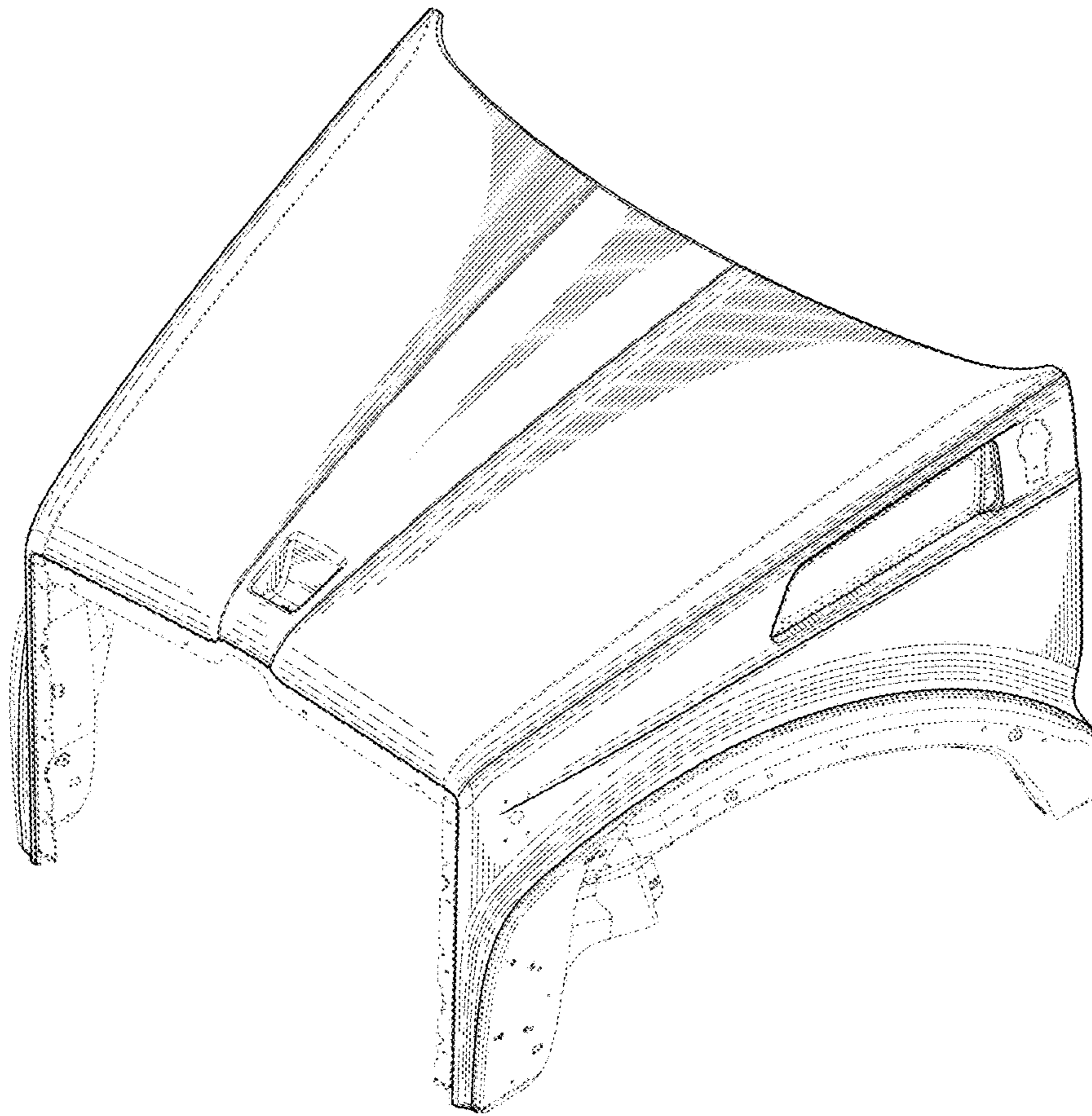
"On-Highway," Peterbilt Motors Company, Denton, Texas, 2013, 13-page brochure.

"Vocational," Peterbilt Motors Company, Denton, Texas, 2013, 11-page brochure.

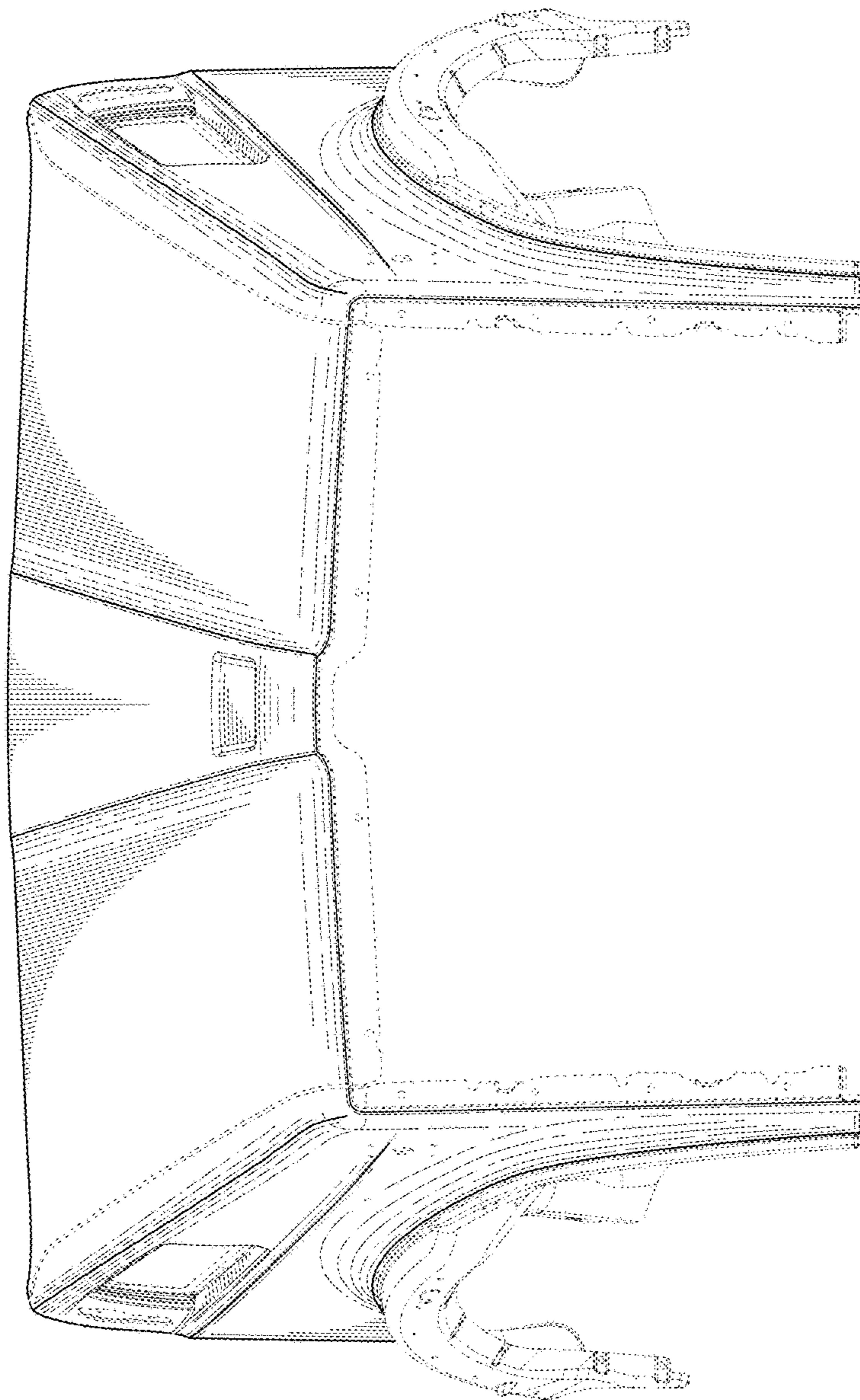
\* cited by examiner



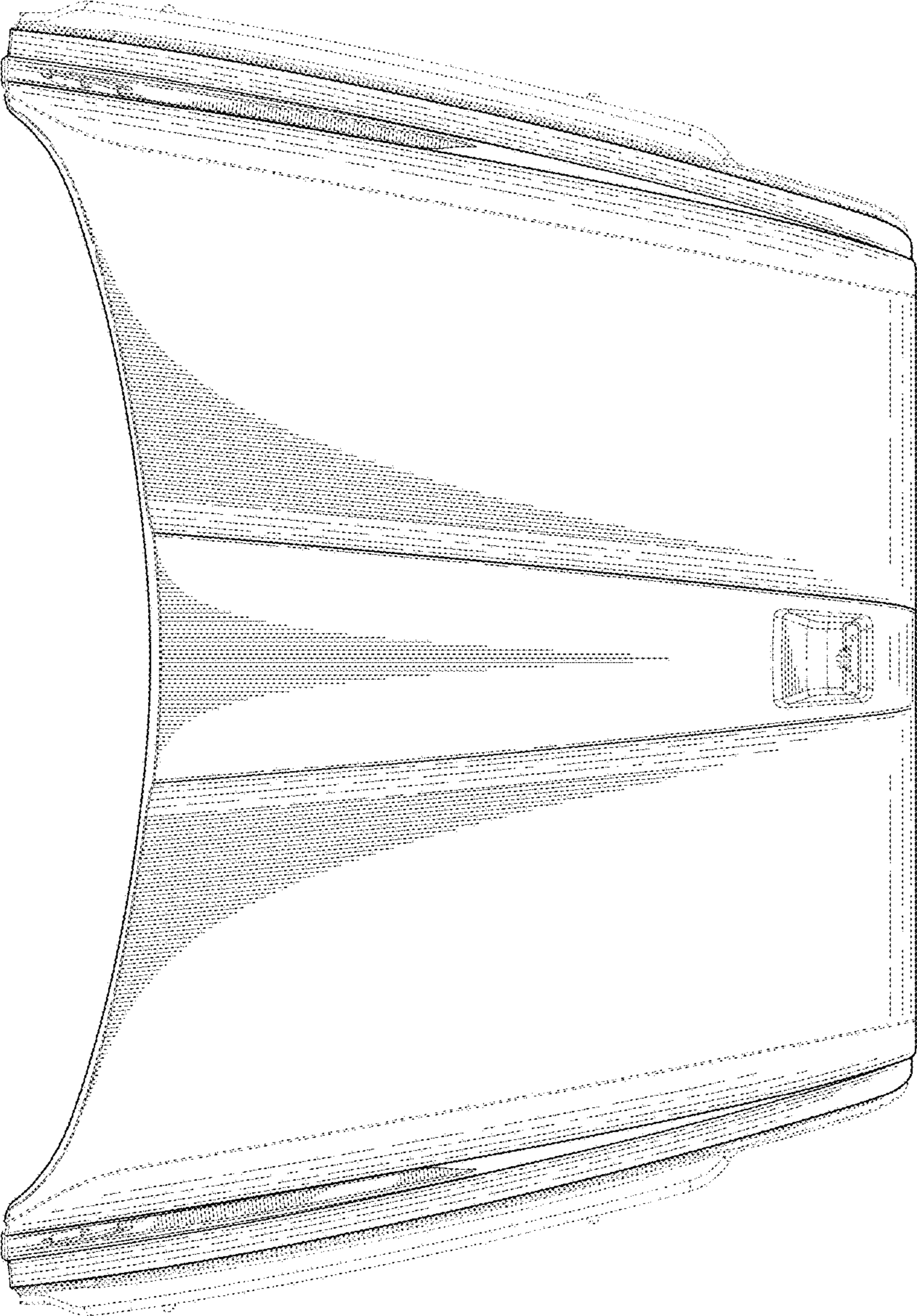
*Fig. 1.*



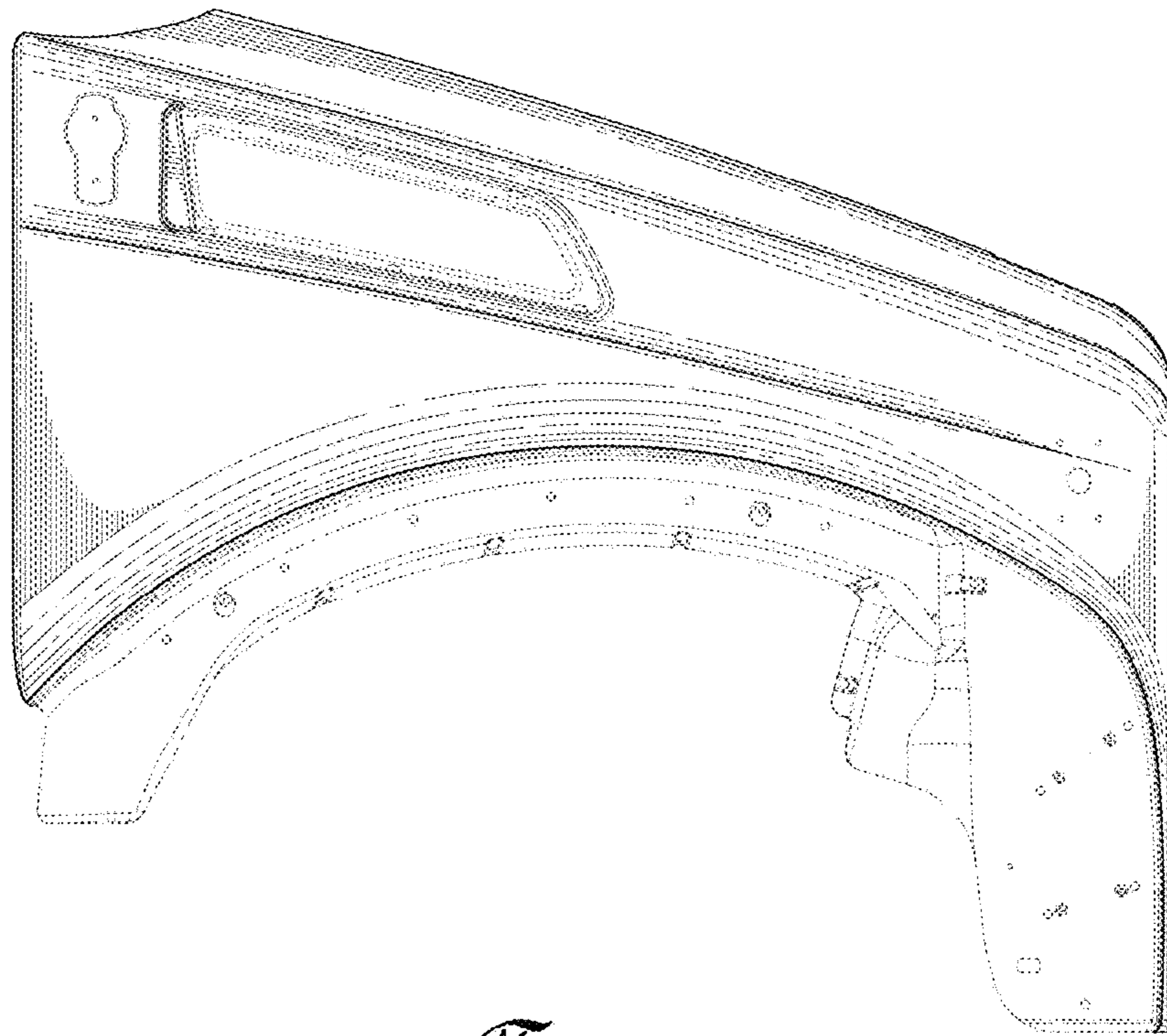
*Fig. 2.*



*Fig. 3.*

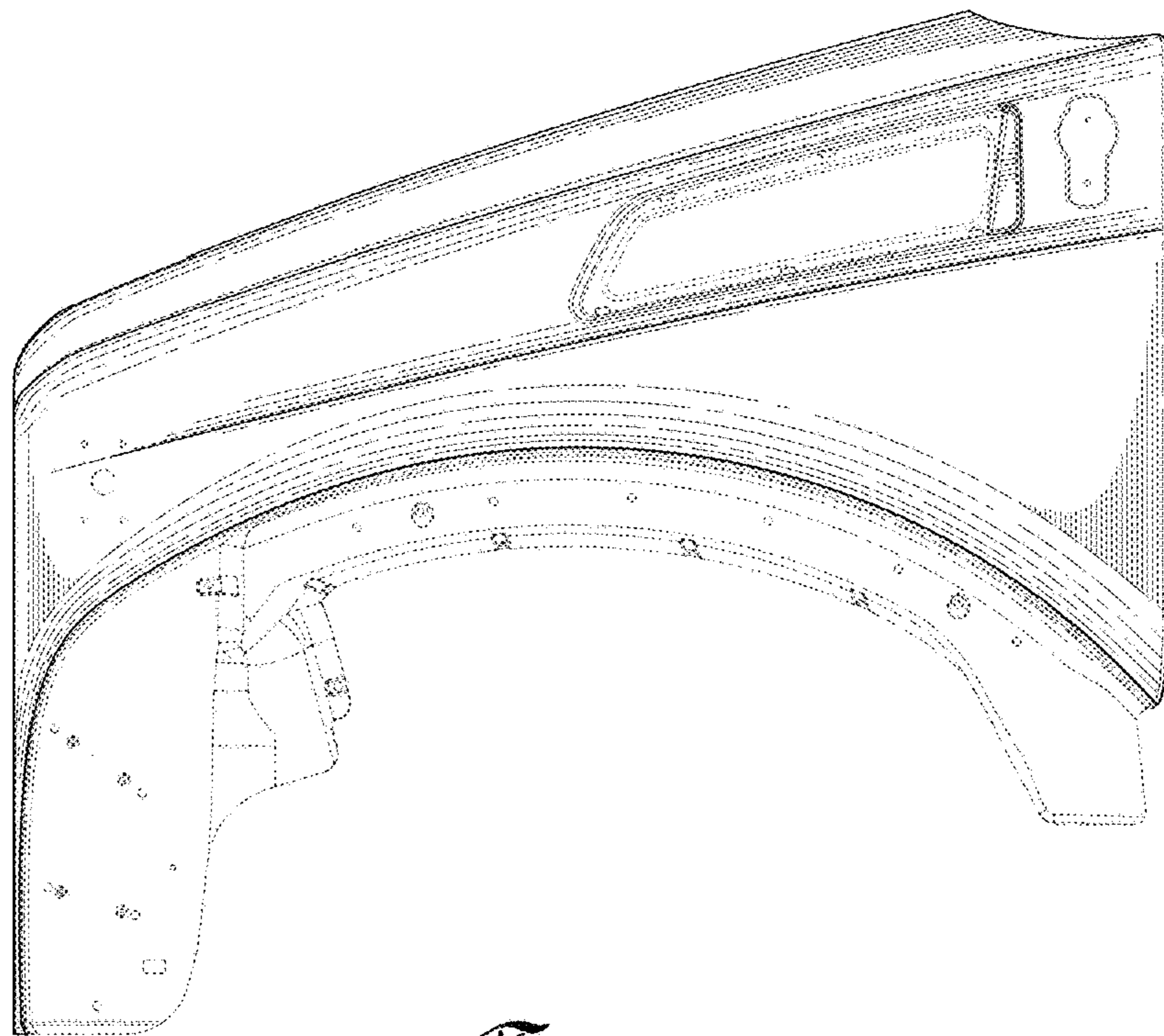


*Fig. 4.*



*Fig. 5.*





*Fig. 6.*