

US00D862294S

(12) **United States Design Patent** (10) **Patent No.:** **US D862,294 S**
McGinley et al. (45) **Date of Patent:** **** Oct. 8, 2019**

(54) **MOTORCYCLE FAIRING**
(71) Applicant: **Harley-Davidson Motor Company Group, LLC, Milwaukee, WI (US)**
(72) Inventors: **Ben McGinley, Glendale, WI (US); Frank Savage, Fox Point, WI (US); Brad Richards, Grafton, WI (US); Richard W. Elchert, Mequon, WI (US)**

D480,670 S * 10/2003 Hanagan D12/182
D485,221 S * 1/2004 Song D12/182
D538,212 S * 3/2007 Shimada D12/182
D538,213 S * 3/2007 Fukuyama D12/182
D596,094 S * 7/2009 Fukuyama D12/182
D690,626 S * 10/2013 Katagiri D12/126
D713,300 S * 9/2014 Tateishi D12/114
D781,755 S * 3/2017 Watanabe D12/114
2007/0210907 A1* 9/2007 Aron B60Q 1/0041
340/465

(73) Assignee: **Harley-Davidson Motor Company Group, LLC, Milwaukee, WI (US)**

* cited by examiner

(**) Term: **15 Years**

Primary Examiner — Michelle E. Wilson
Assistant Examiner — Clese Moore, Jr.

(21) Appl. No.: **29/658,348**

(74) *Attorney, Agent, or Firm* — Foley & Lardner LLP

(22) Filed: **Jul. 30, 2018**

(57) **CLAIM**

(51) **LOC (12) Cl.** **12-11**

We claim the ornamental design for a motorcycle fairing, as shown and described.

(52) **U.S. Cl.**

DESCRIPTION

USPC **D12/114**

(58) **Field of Classification Search**

USPC D12/114, 117, 110, 126, 182, 186, 402
CPC B62J 17/00; B62J 17/02; B62J 17/04
See application file for complete search history.

FIG. 1 is a top, front, perspective view of a motorcycle fairing, showing our new design;
FIG. 2 is a top, rear, right perspective view thereof;
FIG. 3 is a front elevation view thereof;
FIG. 4 is a left side elevation view thereof;
FIG. 5 is a right side elevation view thereof;
FIG. 6 is a top plan view thereof;
FIG. 7 is a bottom plan view thereof; and,
FIG. 8 is a rear elevation view thereof.

(56) **References Cited**

U.S. PATENT DOCUMENTS

D258,127 S * 2/1981 Kamata D12/182
D260,509 S * 9/1981 Guzzetta D12/182
D261,132 S * 10/1981 Vetter D12/182
D266,321 S * 9/1982 Morioka D12/182
D275,093 S * 8/1984 Hunt D12/182
D282,922 S * 3/1986 Abe D12/182
D314,740 S * 2/1991 Abe D12/182

The ornamental design which is claimed is shown in solid lines in the drawings. The broken lines shown illustrate portions of the motorcycle fairing that form no part of the claimed design.

1 Claim, 8 Drawing Sheets

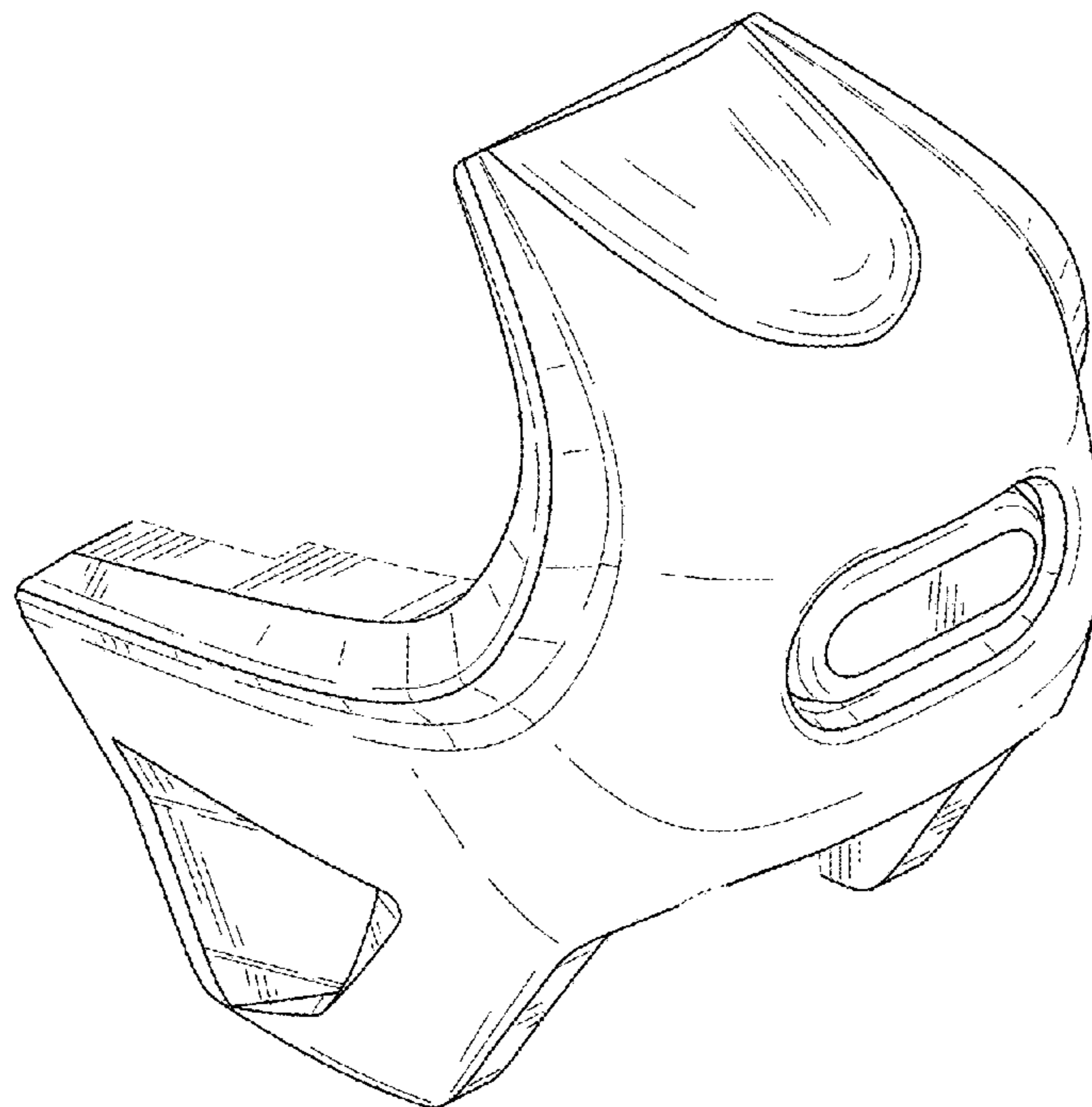

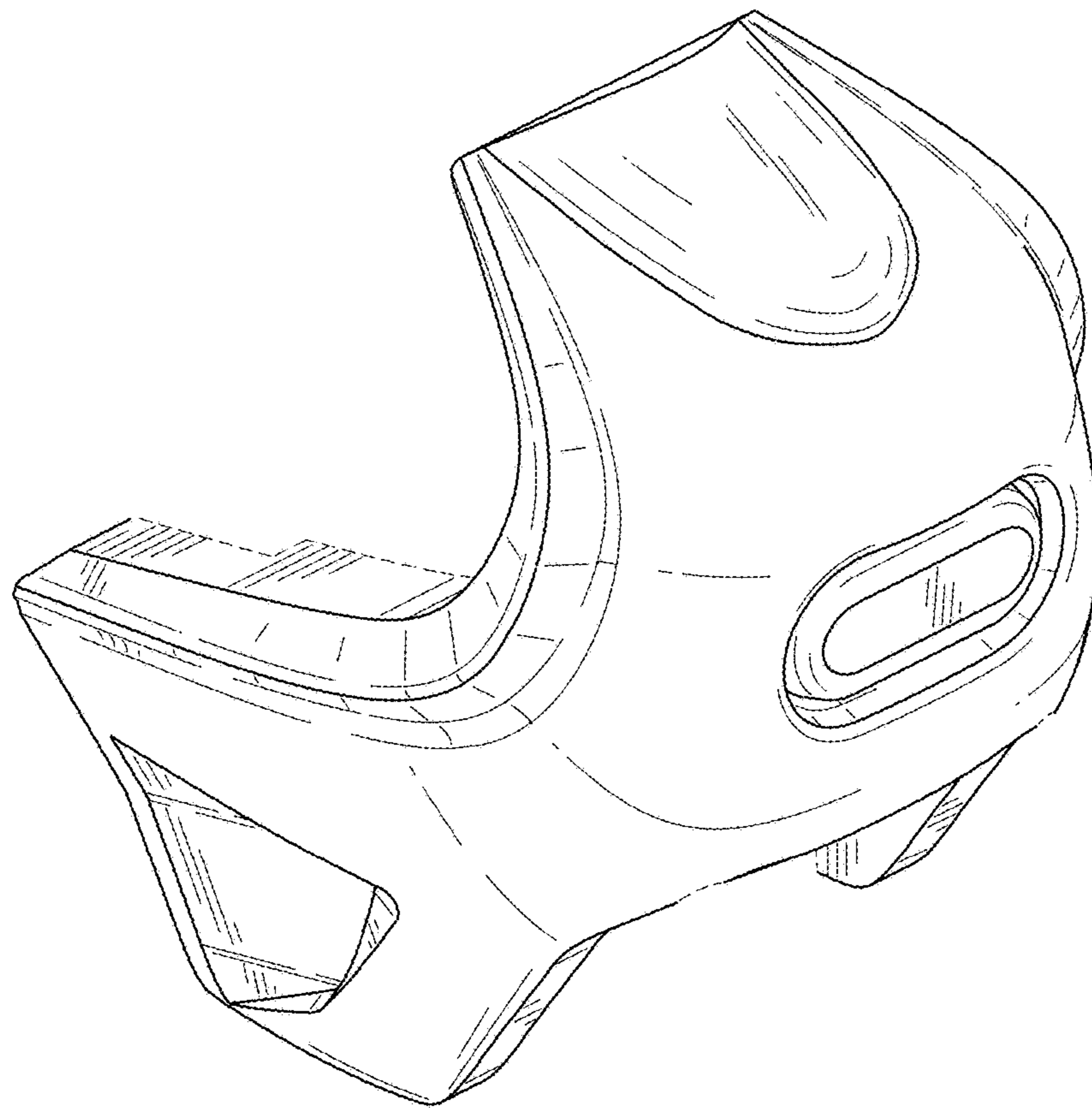

FIG. 1

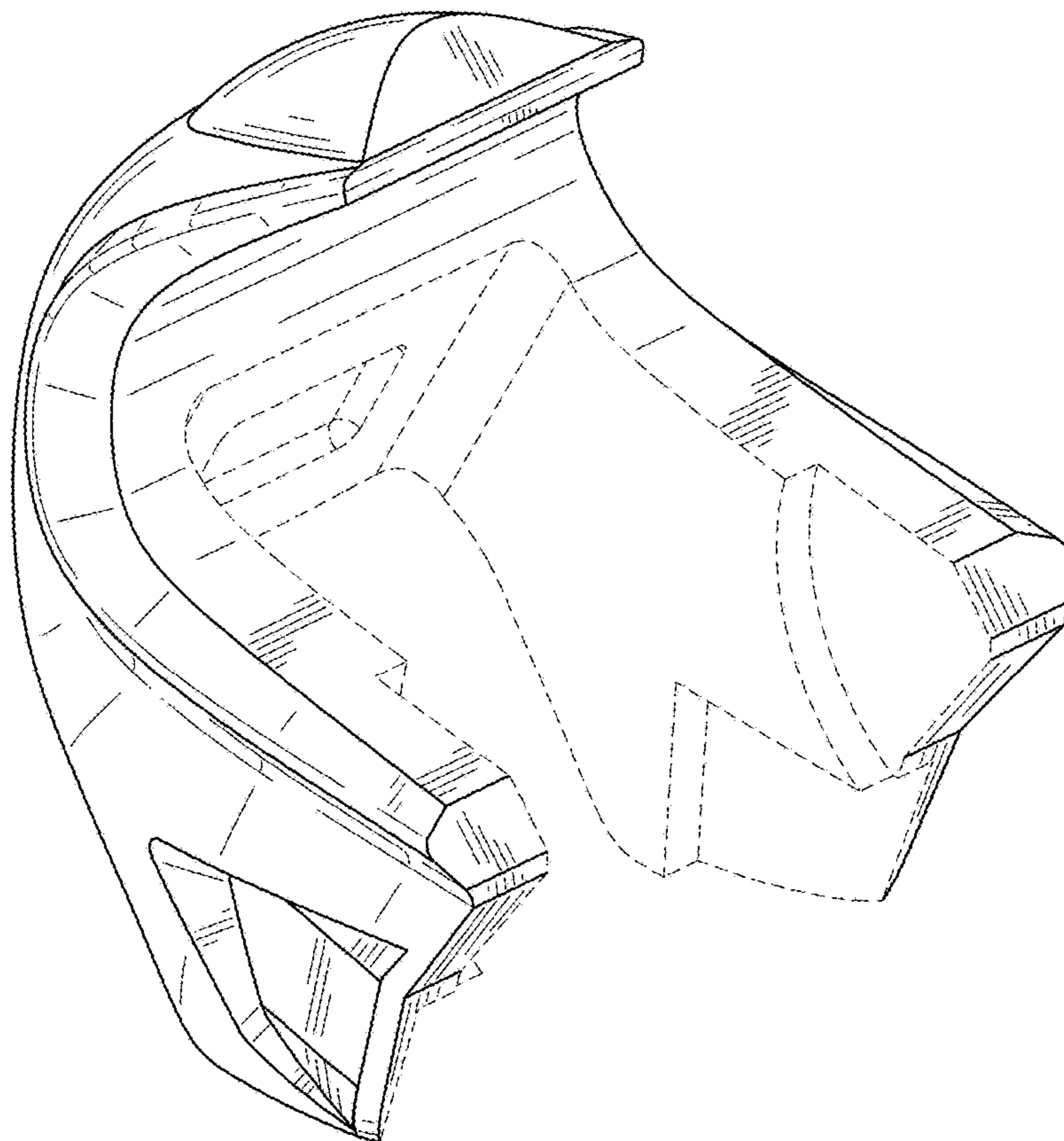

FIG. 2

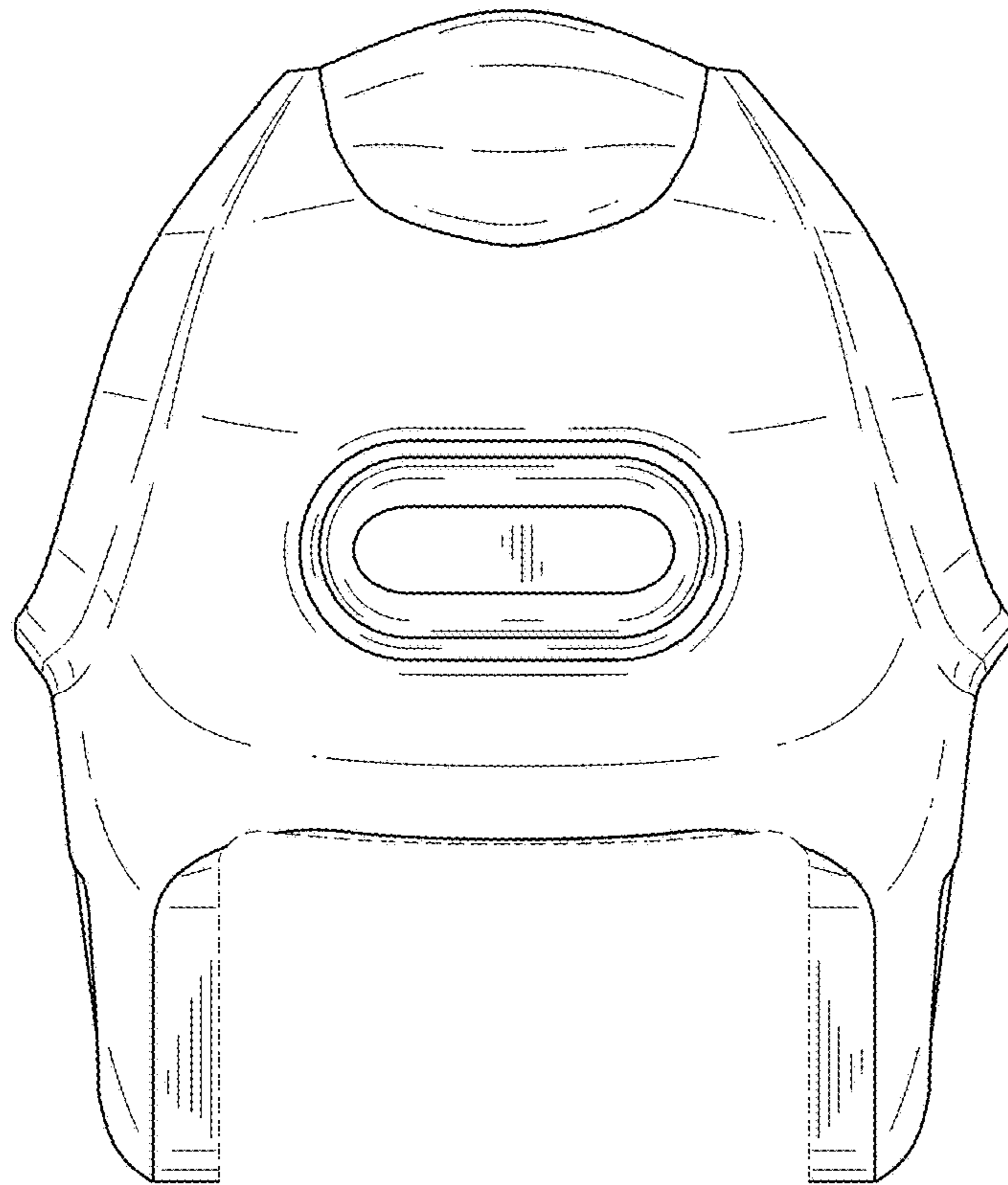

FIG. 3

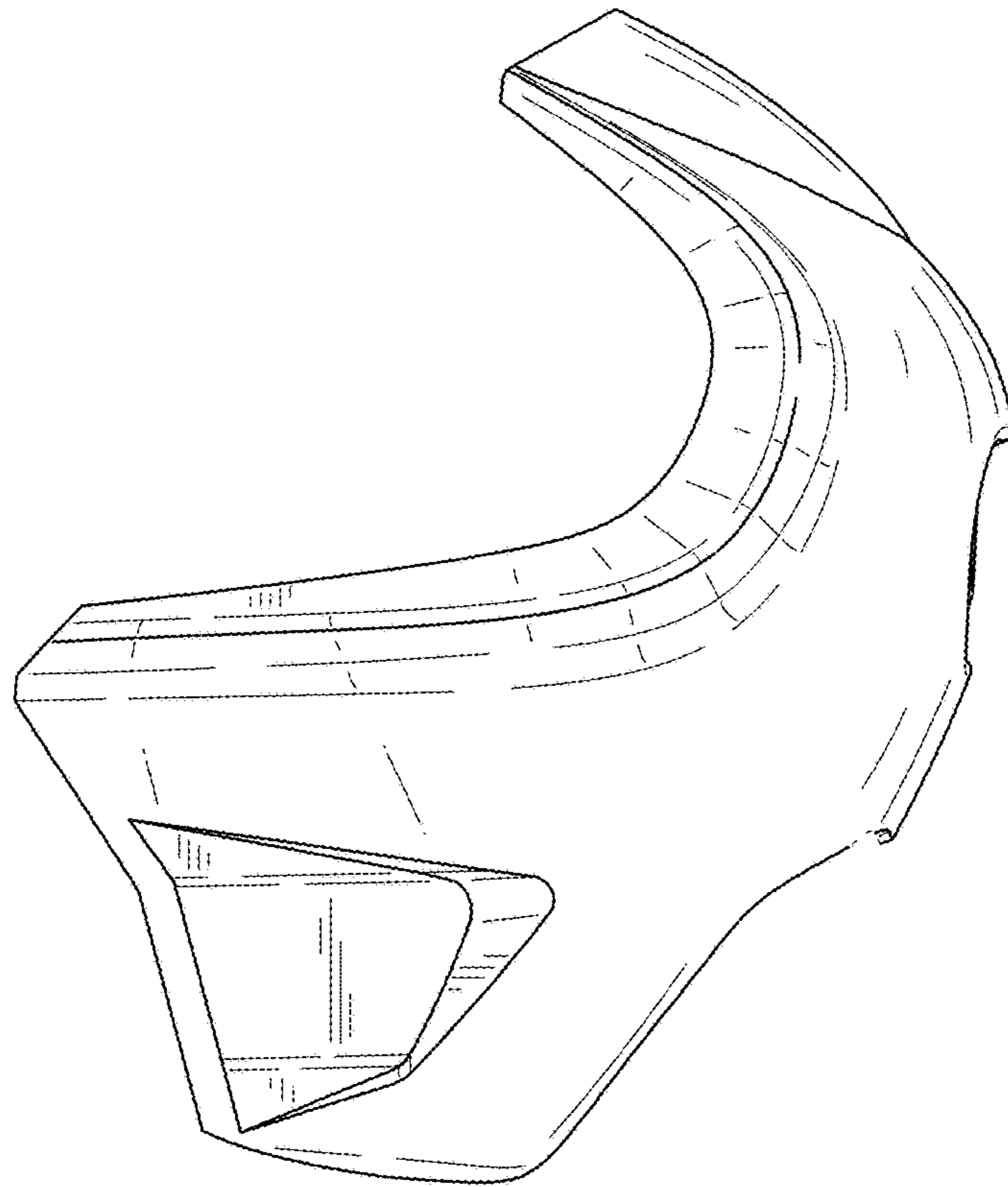

FIG. 4

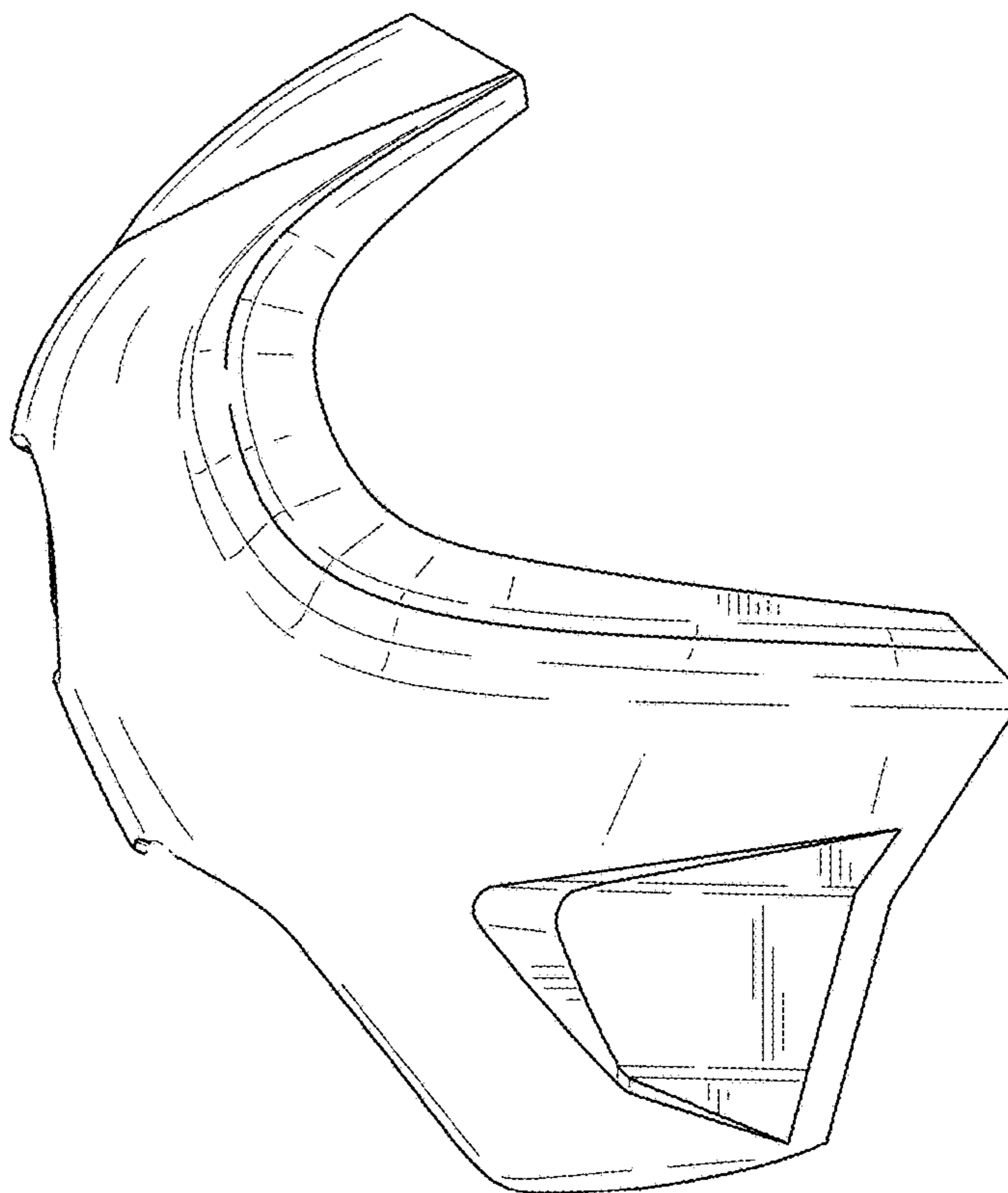

FIG. 5

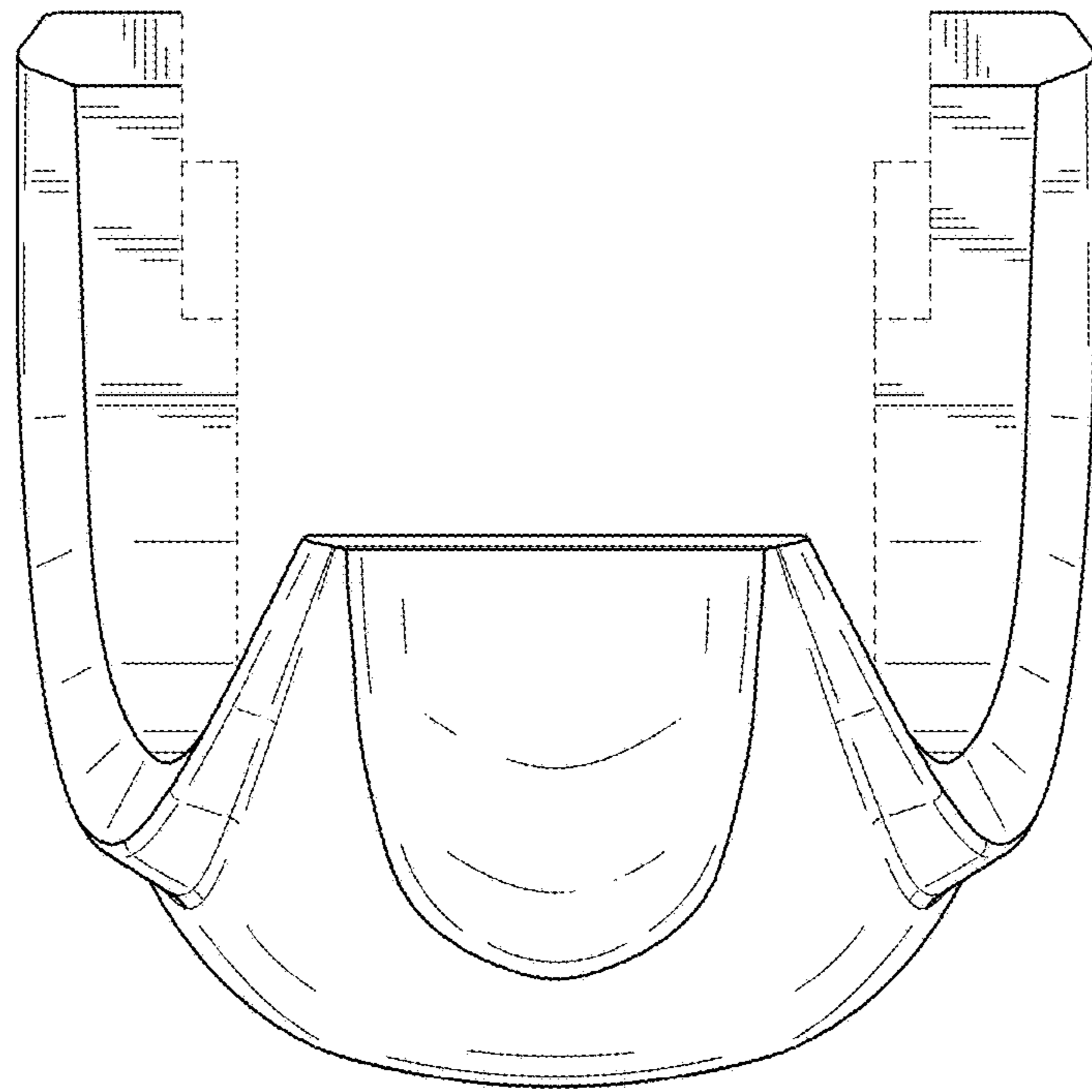

FIG. 6

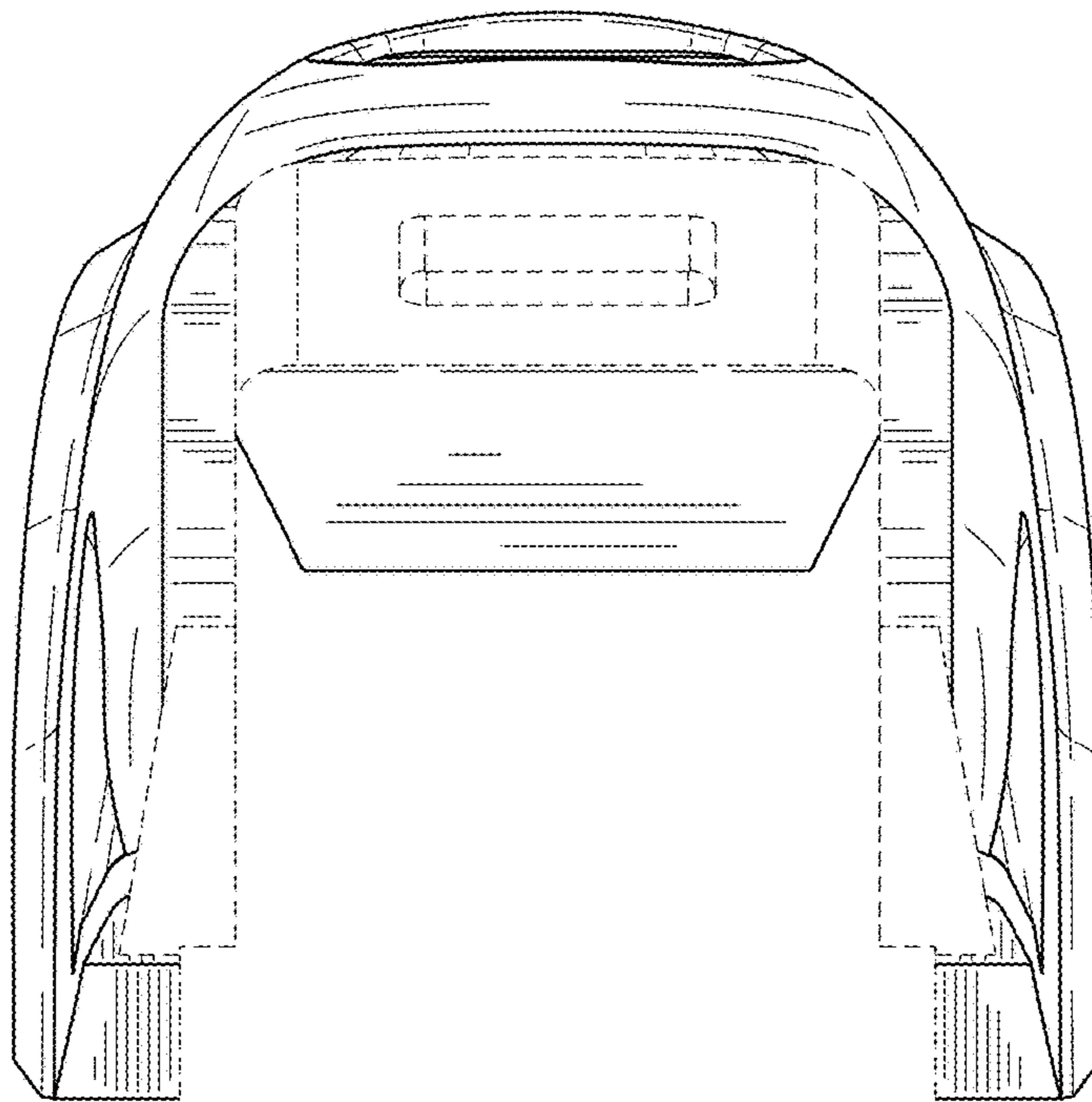

FIG. 7

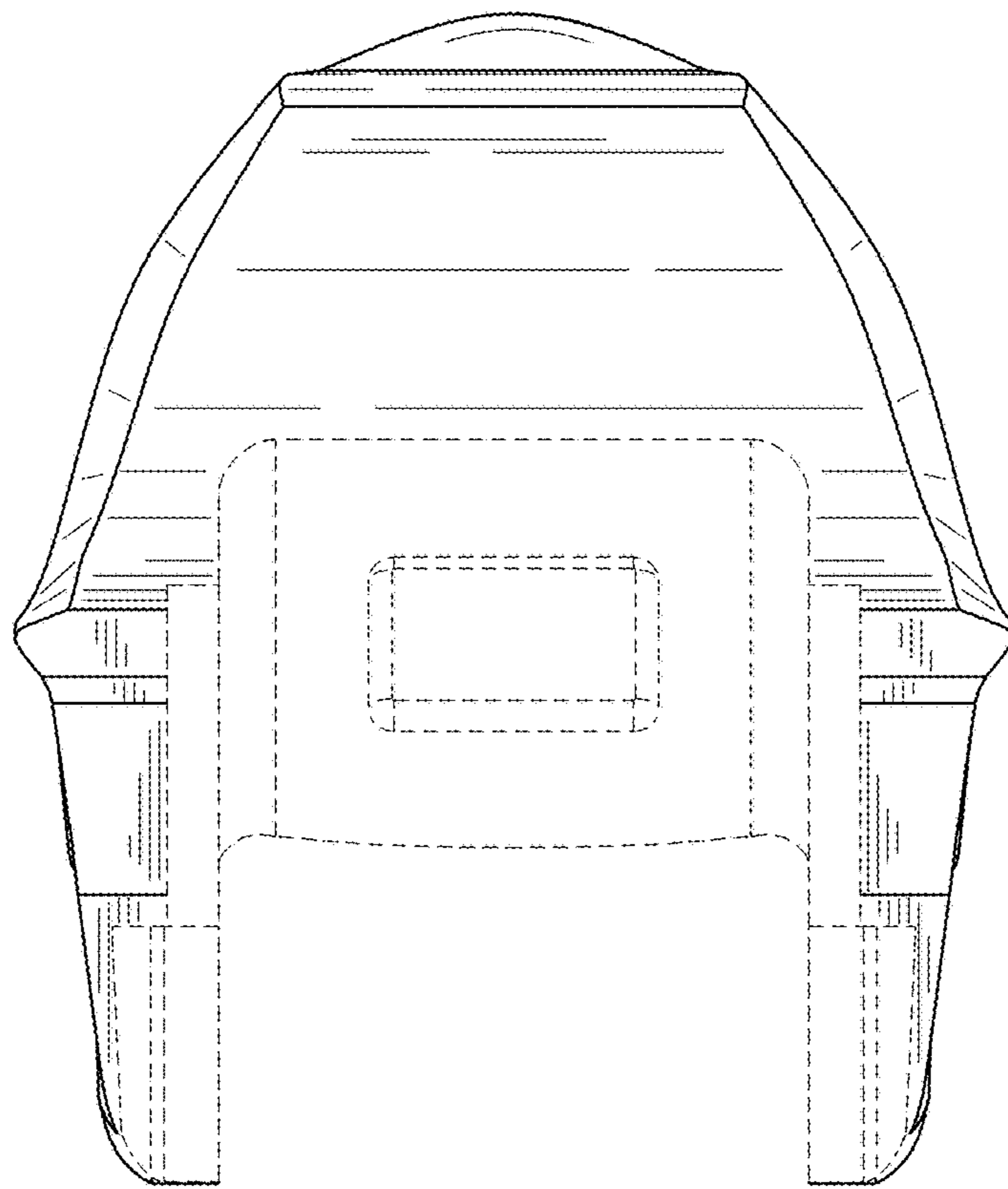

FIG. 8