



US00D861915S

(12) **United States Design Patent**  
**Zakrys et al.**

(10) **Patent No.:** **US D861,915 S**  
(45) **Date of Patent:** **\*\* Oct. 1, 2019**

- (54) **CASSETTE ASSEMBLY FOR ELECTROPHORESIS GEL**
- (71) Applicants: **THERMO FISHER SCIENTIFIC BALTICS UAB**, Carlsbad, CA (US); **THERMO FISHER ISRAEL LTD.**, Carlsbad, CA (US)
- (72) Inventors: **Linas Zakrys**, Vilnius (LT); **Paulius Mielinis**, Vilnius (LT); **Ronen Benarieh**, Givat brener (IL)
- (73) Assignees: **THERMO FISHER SCIENTIFIC BALTICS UAB** (LT); **THERMO FISHER ISRAEL LTD** (IL)
- (\*\*) Term: **15 Years**
- (21) Appl. No.: **29/617,362**
- (22) Filed: **Sep. 13, 2017**
- (51) **LOC (12) Cl.** ..... **24-01**
- (52) **U.S. Cl.**  
USPC ..... **D24/233; D24/224**
- (58) **Field of Classification Search**  
USPC ..... **D24/216, 223-233, 186, 107; D10/81**  
(Continued)

(56) **References Cited**

**U.S. PATENT DOCUMENTS**

- 7,601,251 B2 \* 10/2009 Rooney ..... C07K 1/26  
204/456
- D698,938 S \* 2/2014 Fonseca ..... B01L 3/5088  
D24/224

(Continued)

*Primary Examiner* — Anhdao Doan

(57) **CLAIM**

The ornamental design for cassette assembly for electrophoresis gel, as shown and described.

**DESCRIPTION**

FIG. 1 is an exploded front perspective of a cassette assembly for electrophoresis gel

FIG. 2 is a front perspective view of the assembled cassette assembly for electrophoresis gel, of FIG. 1;  
 FIG. 3 is a back perspective view of the cassette assembly for electrophoresis gel, of FIG. 2;  
 FIG. 4 is a front view of the cassette assembly for electrophoresis gel, of FIG. 2;  
 FIG. 5 is a back view of the cassette assembly for electrophoresis gel, of FIG. 2;  
 FIG. 6 is a right side view of the cassette assembly for electrophoresis gel, of FIG. 2;  
 FIG. 7 is a left side view of the cassette assembly for electrophoresis gel, of FIG. 2;  
 FIG. 8 is a top view of the cassette assembly for electrophoresis gel, of FIG. 2;  
 FIG. 9 is a bottom view of the cassette assembly for electrophoresis gel, of FIG. 2;  
 FIG. 10 is an exploded front perspective view of the top and bottom plates of the cassette assembly for electrophoresis gel, of FIG. 1;  
 FIG. 11 is a front perspective view of the top and bottom plates of the assembled cassette assembly for electrophoresis gel, of FIG. 10;  
 FIG. 12 is a back perspective view of the top and bottom plates of the cassette assembly for electrophoresis gel, of FIG. 11;  
 FIG. 13 is a front view of the top and bottom plates of the cassette assembly for electrophoresis gel, of FIG. 11;  
 FIG. 14 is a back view of the top and bottom plates of the cassette assembly for electrophoresis gel, of FIG. 11;  
 FIG. 15 is a right side view of the top and bottom plates of the cassette assembly for electrophoresis gel, of FIG. 11;  
 FIG. 16 is a left side view of the top and bottom plates of the cassette assembly for electrophoresis gel, of FIG. 11;  
 FIG. 17 is a top view of the top and bottom plates of the cassette assembly for electrophoresis gel, of FIG. 11;  
 FIG. 18 is a bottom view of the top and bottom plates of the cassette assembly for electrophoresis gel, of FIG. 11;  
 FIG. 19 is an exploded front perspective view of the top plate and comb of the cassette assembly for electrophoresis gel, of FIG. 1;  
 FIG. 20 is a front perspective view of the top plate and comb of the assembled cassette assembly for electrophoresis gel, of FIG. 19;

(Continued)

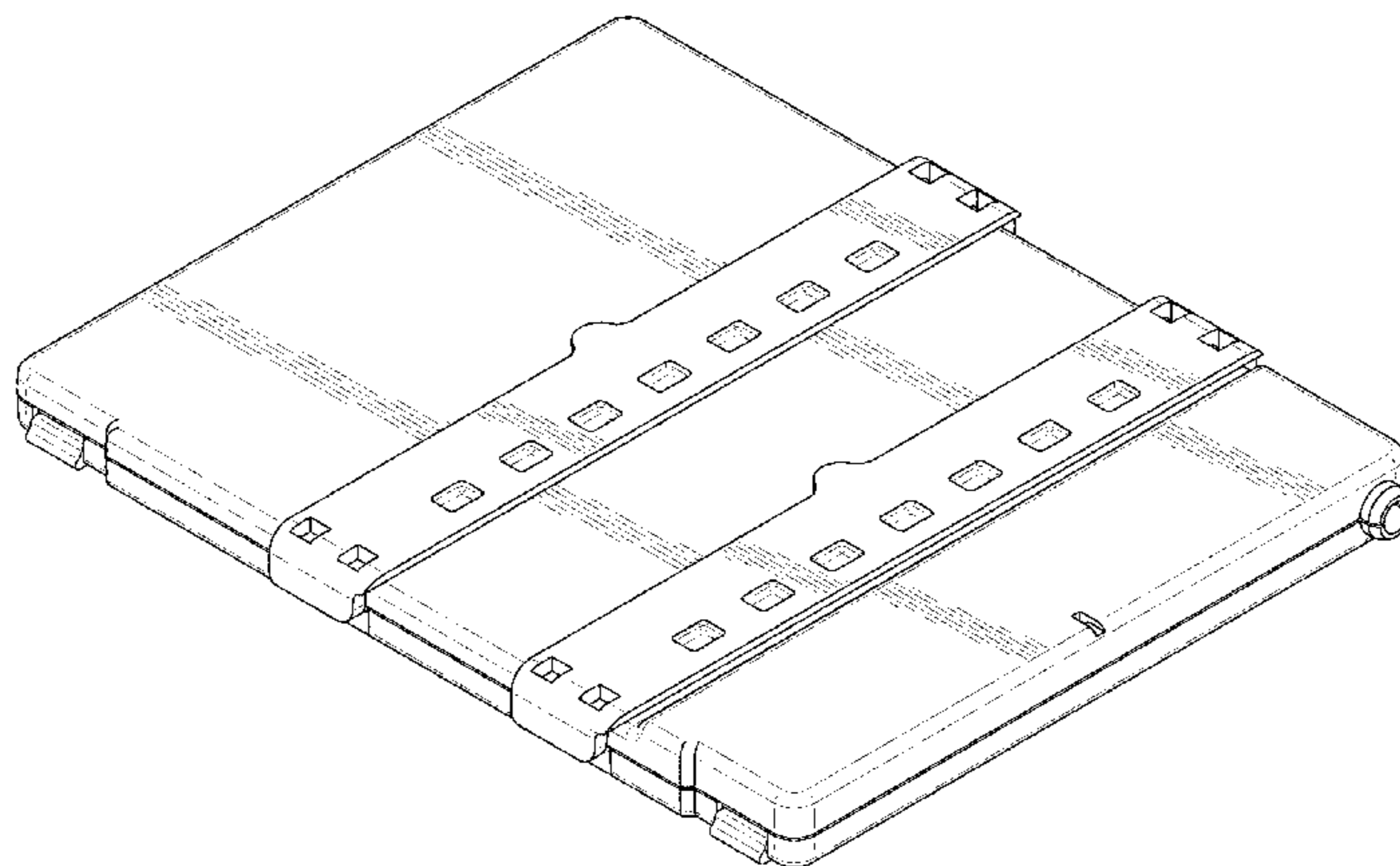

FIG. 21 is a back perspective view of the top plate and comb of the cassette assembly for electrophoresis gel, of FIG. 20; FIG. 22 is a front view of the top plate and comb of the cassette assembly for electrophoresis gel, of FIG. 20; FIG. 23 is a back view of the top plate and comb of the cassette assembly for electrophoresis gel, of FIG. 20; FIG. 24 is a right side view of the top plate and comb of the cassette assembly for electrophoresis gel, of FIG. 20; FIG. 25 is a left side view of the top plate and comb of the cassette assembly for electrophoresis gel, of FIG. 20; FIG. 26 is a top view of the top plate and comb of the cassette assembly for electrophoresis gel, of FIG. 20; FIG. 27 is a bottom view of the top plate and comb of the cassette assembly for electrophoresis gel, of FIG. 20; FIG. 28 is a front perspective view of the comb of the cassette assembly for electrophoresis gel, of FIG. 1; FIG. 29 is a back perspective view of the comb of the cassette assembly for electrophoresis gel, of FIG. 28; FIG. 30 is a front view of the comb of the cassette assembly for electrophoresis gel, of FIG. 28; FIG. 31 is a back view of the comb of the cassette assembly for electrophoresis gel, of FIG. 28; FIG. 32 is a right side view of the comb of the cassette assembly for electrophoresis gel, of FIG. 28; FIG. 33 is a left side view of the comb of the cassette assembly for electrophoresis gel, of FIG. 28; FIG. 34 is a top view of the comb of the cassette assembly for electrophoresis gel, of FIG. 28; FIG. 35 is a bottom view of the comb of the cassette assembly for electrophoresis gel, of FIG. 28; FIG. 36 is a front perspective view of the top plate of the cassette assembly for electrophoresis gel, of FIG. 1; FIG. 37 is a back perspective view of the top plate of the cassette assembly for electrophoresis gel, of FIG. 36; FIG. 38 is a front view of the top plate of the cassette assembly for electrophoresis gel, of FIG. 36; FIG. 39 is a back view of the top plate of the cassette assembly for electrophoresis gel, of FIG. 36; FIG. 40 is a right side view of the top plate of the cassette assembly for electrophoresis gel, of FIG. 36; FIG. 41 is a left side view of the top plate of the cassette assembly for electrophoresis gel, of FIG. 36; FIG. 42 is a top view of the top plate of the cassette assembly for electrophoresis gel, of FIG. 36; FIG. 43 is a bottom view of the top plate of the cassette assembly for electrophoresis gel, of FIG. 36;

FIG. 44 is a front perspective view of the bottom plate of the cassette assembly for electrophoresis gel, of FIG. 1; FIG. 45 is a back perspective view of the bottom plate of the cassette assembly for electrophoresis gel, of FIG. 44; FIG. 46 is a front view of the bottom plate of the cassette assembly for electrophoresis gel, of FIG. 44; FIG. 47 is a back view of the bottom plate of the cassette assembly for electrophoresis gel, of FIG. 44; FIG. 48 is a right side view of the bottom plate of the cassette assembly for electrophoresis gel, of FIG. 44; FIG. 49 is a left side view of the bottom plate of the cassette assembly for electrophoresis gel, of FIG. 44; FIG. 50 is a top view of the bottom plate of the cassette assembly for electrophoresis gel, of FIG. 44; and, FIG. 51 is a bottom view of the bottom plate of the cassette assembly for electrophoresis gel, of FIG. 44.

**1 Claim, 50 Drawing Sheets**

(58) **Field of Classification Search**

CPC .... B01L 3/5027; B01L 3/502707; B01L 9/52; B01L 9/523; B01L 9/527; B01L 2300/0609; B01L 2300/0809; B01L 2300/0877; B01L 2200/027; G01N 27/447; G01N 27/44704; G01N 27/44756; G01N 27/44747; C07K 1/26  
See application file for complete search history.

(56) **References Cited**

U.S. PATENT DOCUMENTS

D733,918	S *	7/2015	Sjolander .....	D24/233
9,234,874	B2 *	1/2016	Panattoni .....	G01N 27/44704
D812,767	S *	3/2018	Osmus .....	D24/225
2005/0023139	A1 *	2/2005	Rooney .....	G01N 27/44704 204/450
2005/0164404	A1 *	7/2005	Marlborough .....	B01L 3/5023 436/514
2006/0163067	A1 *	7/2006	Sevigny .....	B29C 51/30 204/465
2011/0062024	A1 *	3/2011	Sabin .....	G01N 27/44756 204/457
2015/0160156	A1 *	6/2015	Otonashi .....	G01N 27/44743 204/466
2015/0192542	A1 *	7/2015	Larsson .....	G01N 27/44704 204/620

\* cited by examiner

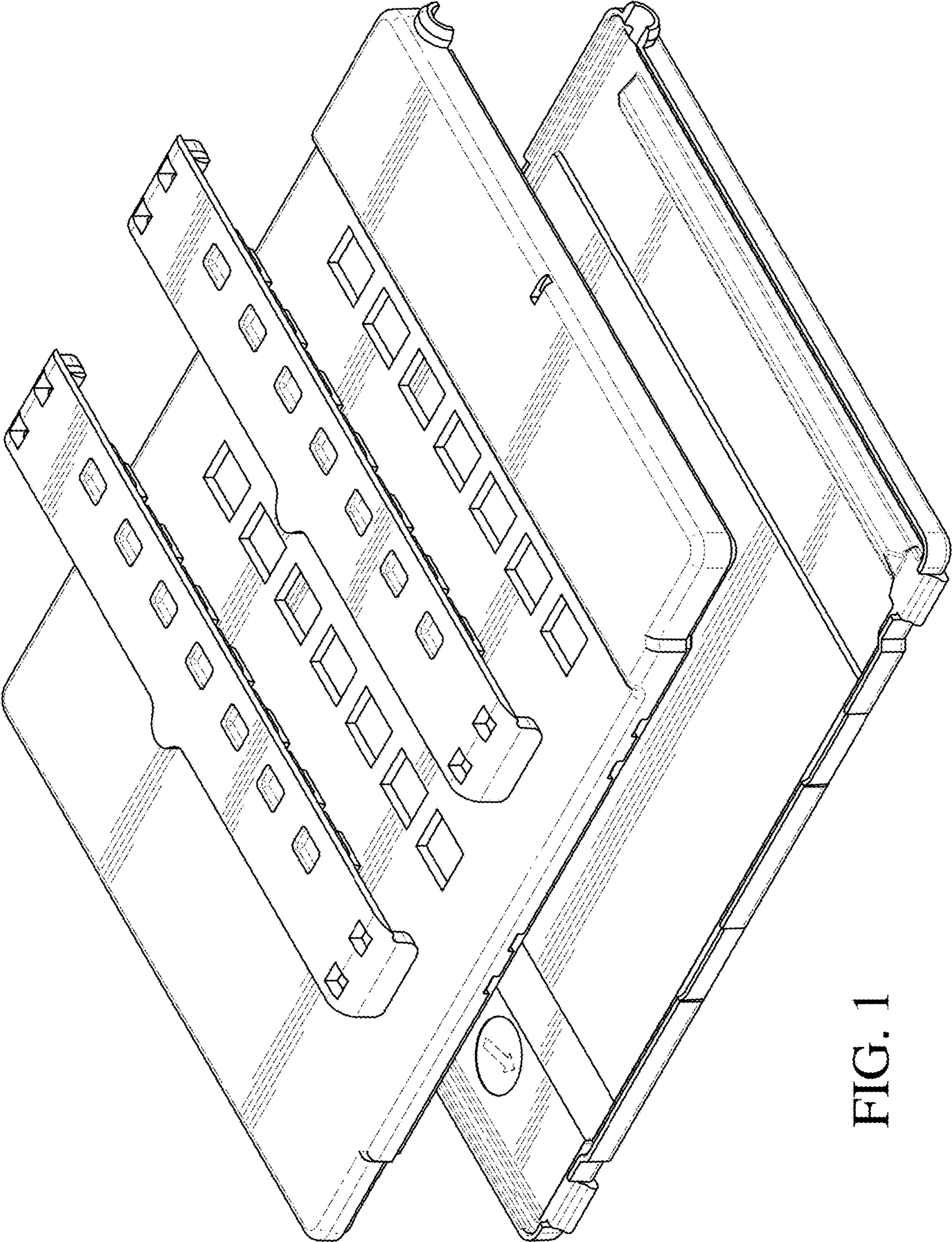

FIG. 1

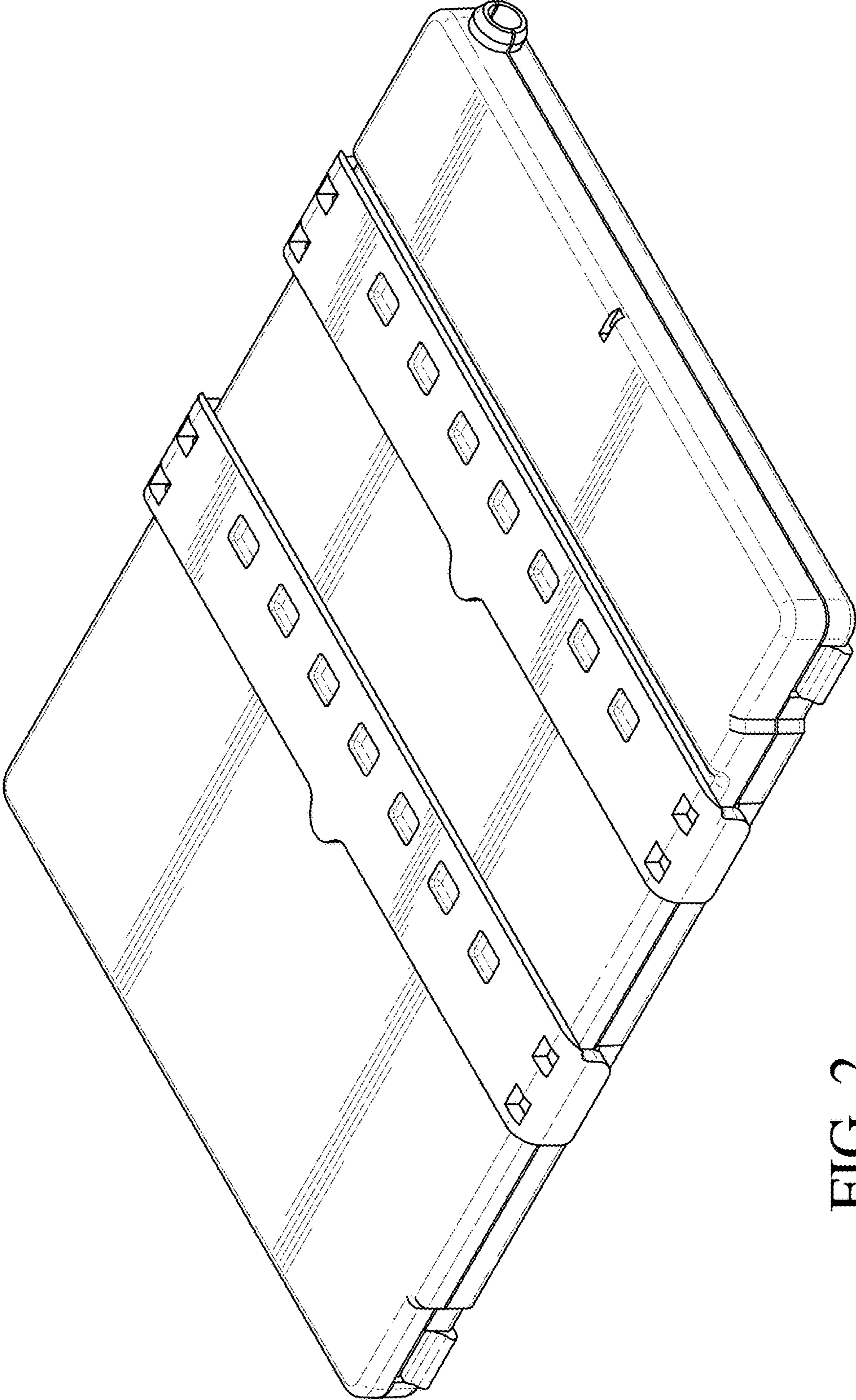

FIG. 2

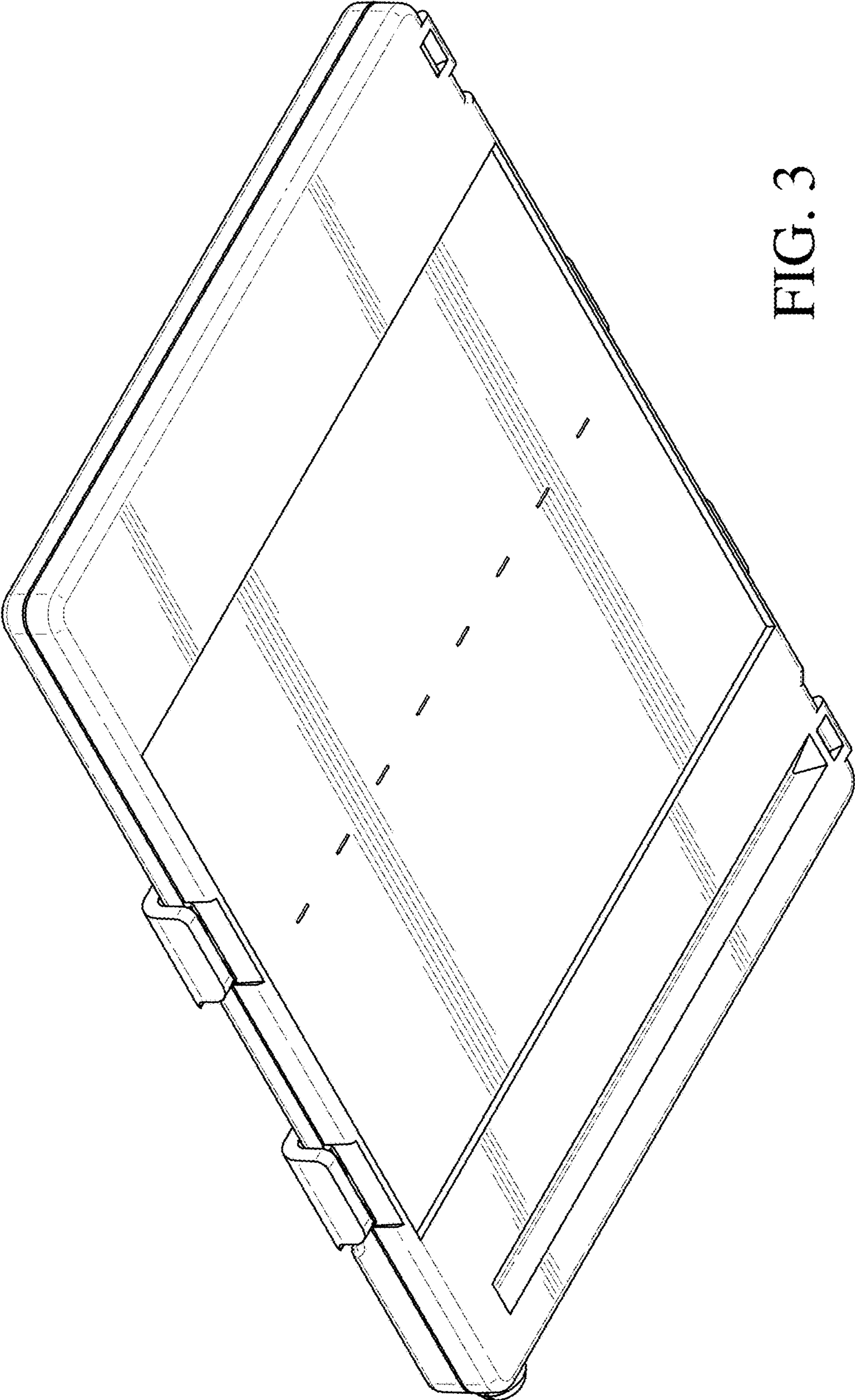

FIG. 3

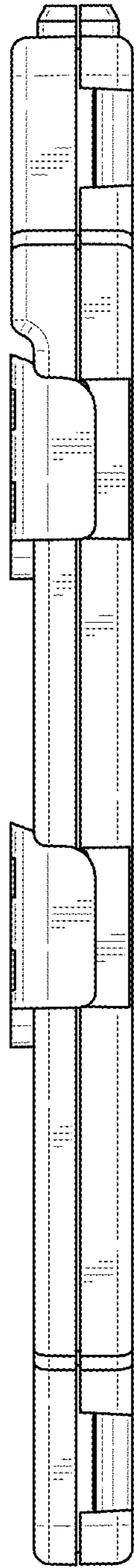

FIG. 4

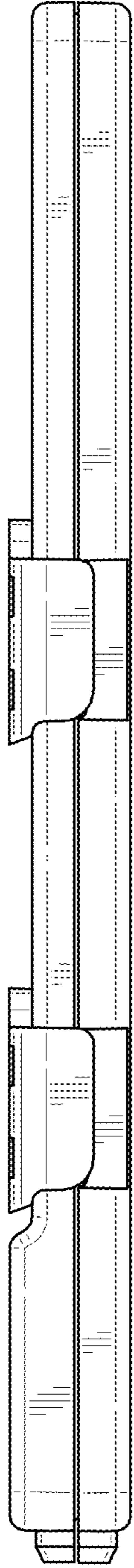

FIG. 5

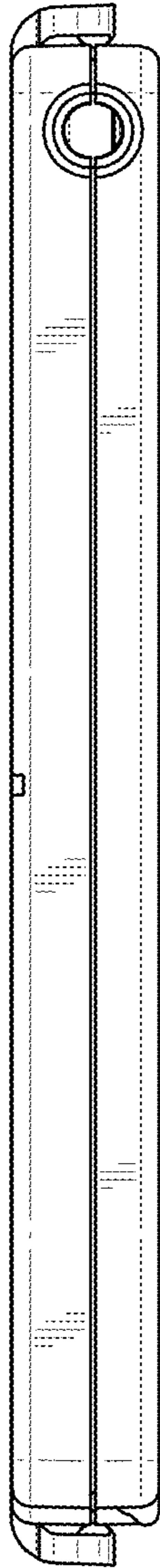

FIG. 6



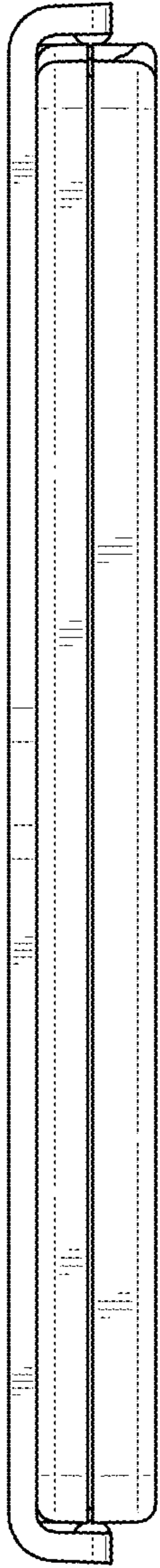

FIG. 7

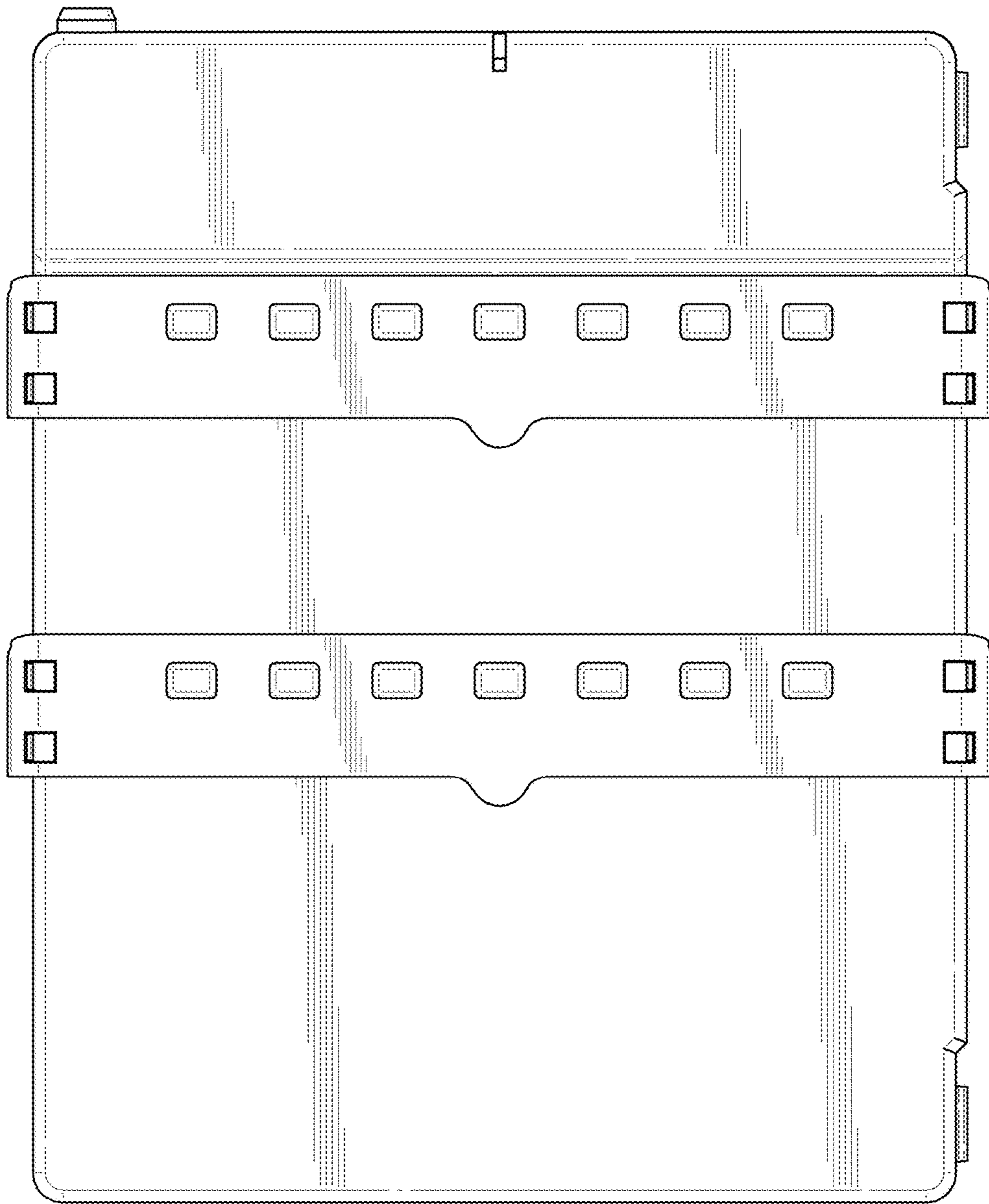

FIG. 8

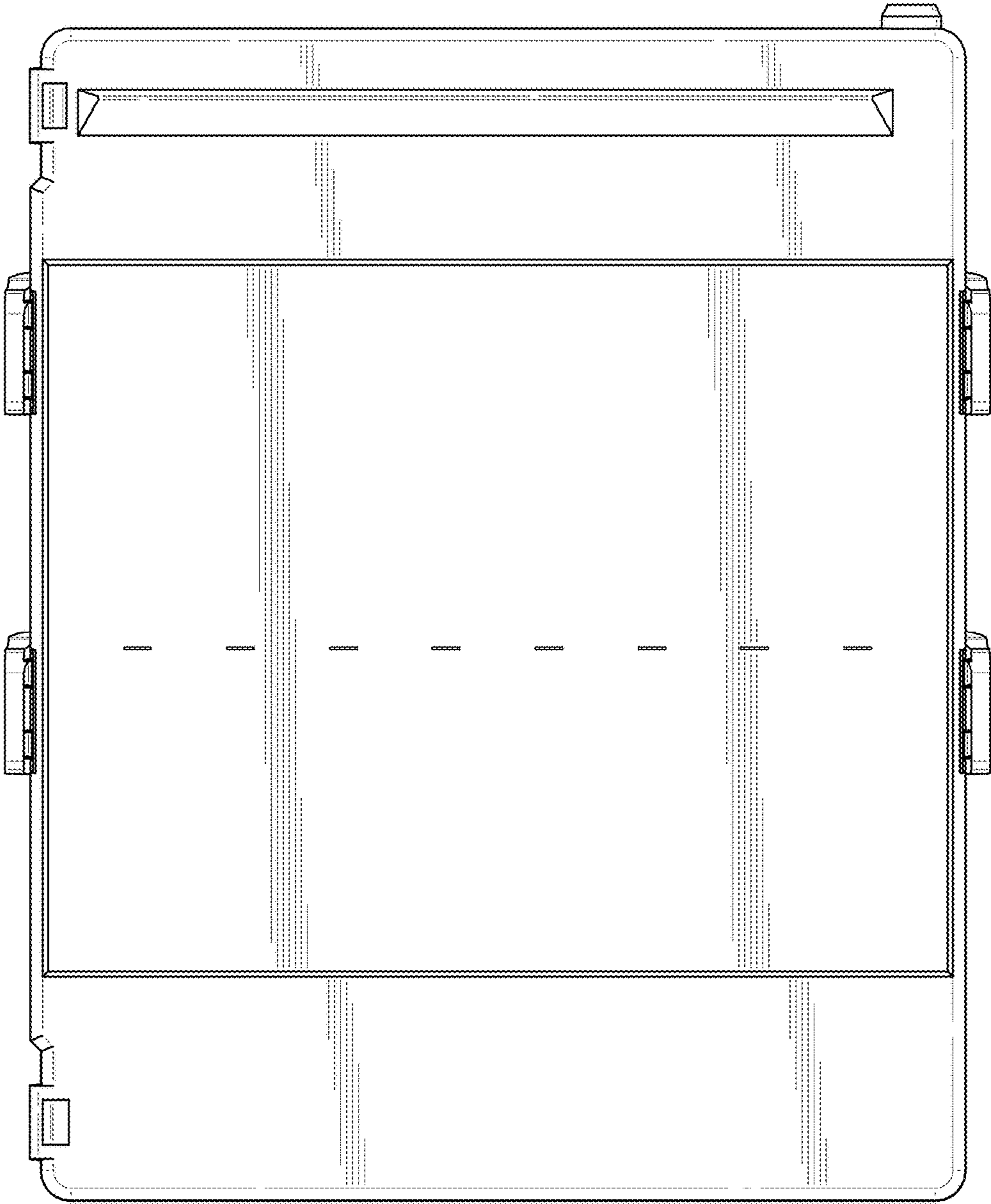

FIG. 9

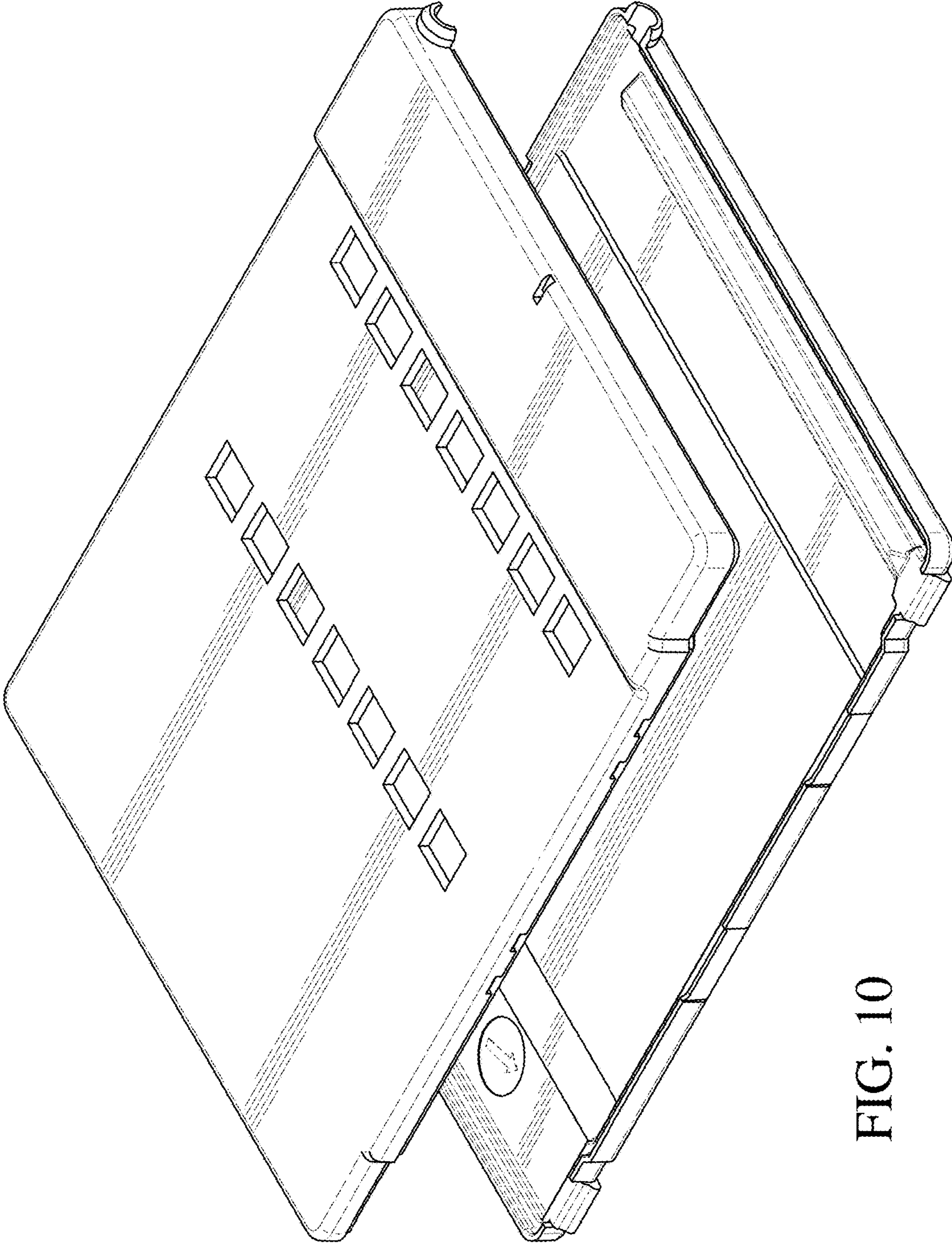

FIG. 10

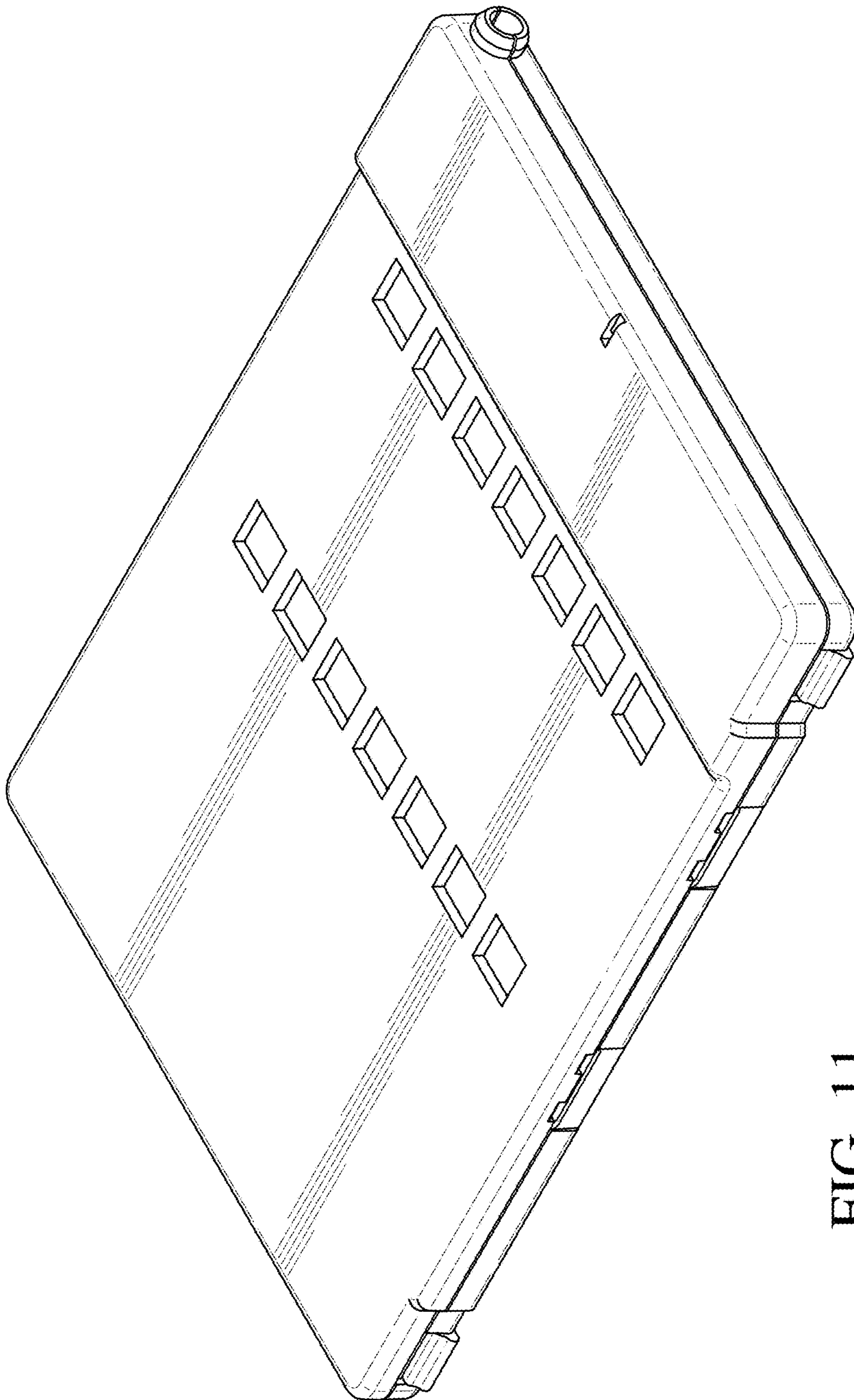

FIG. 11

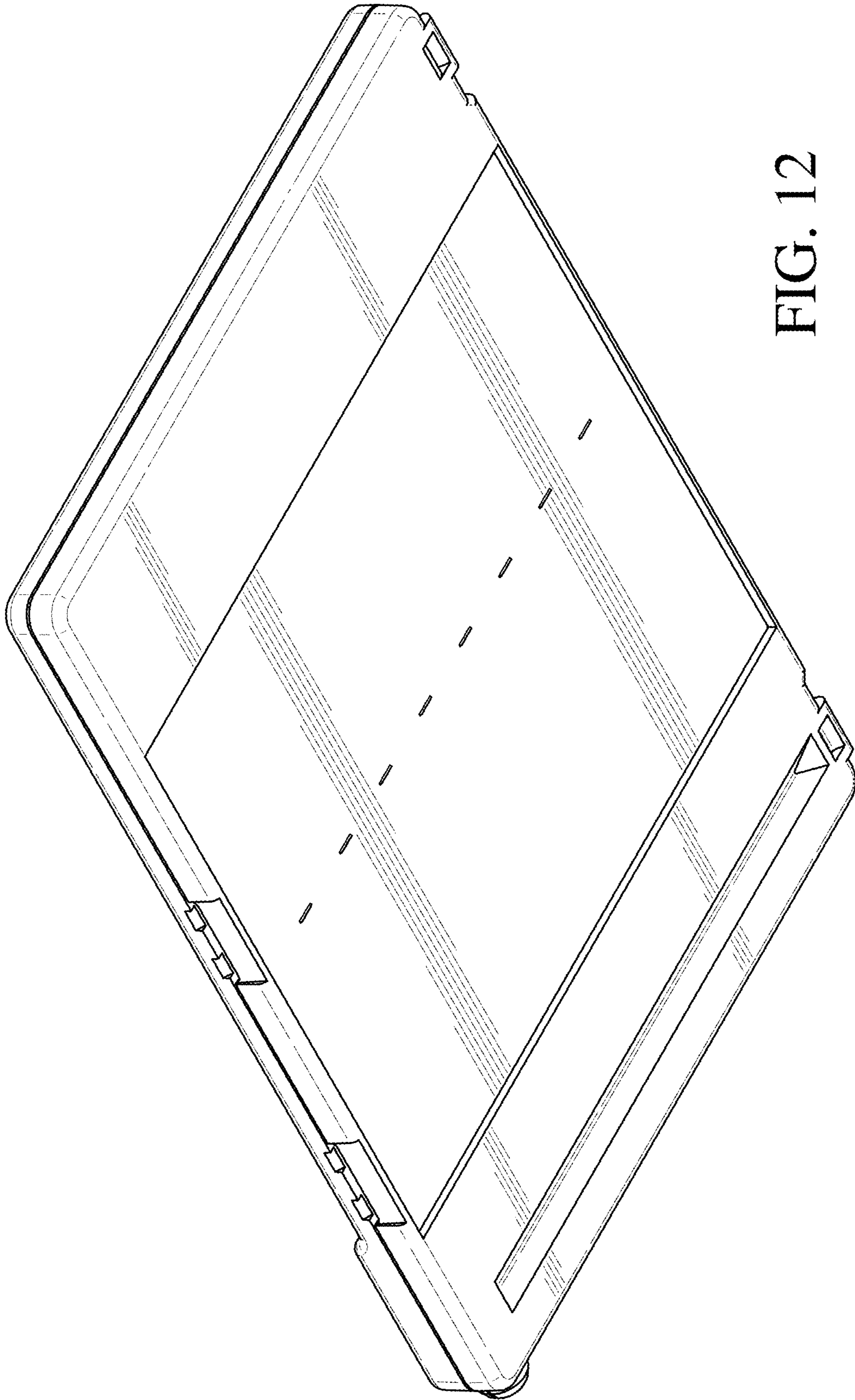

FIG. 12

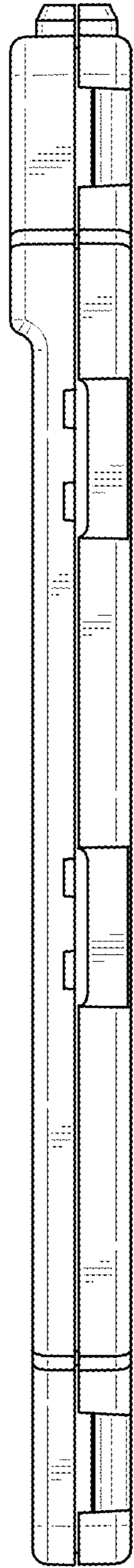

FIG. 13

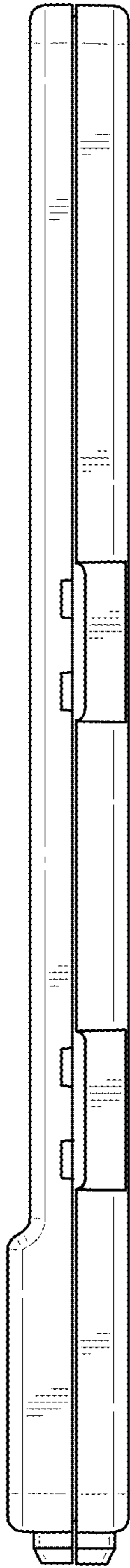

FIG. 14



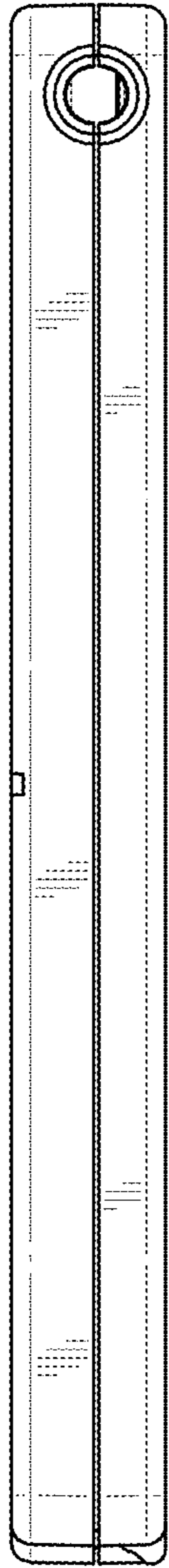

FIG. 15

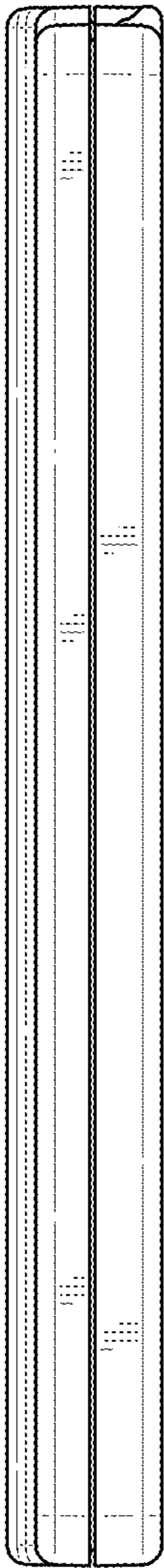

FIG. 16

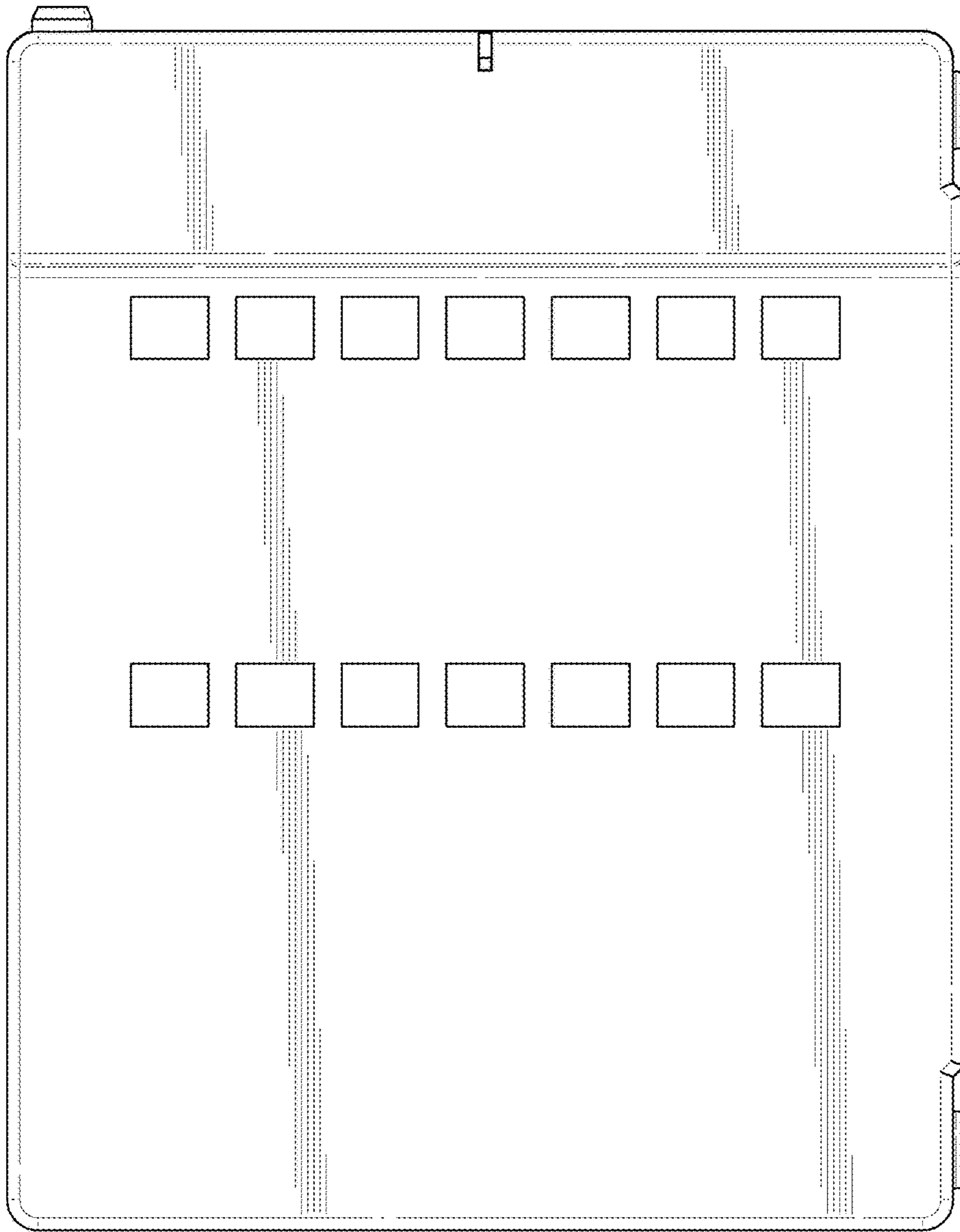

FIG. 17

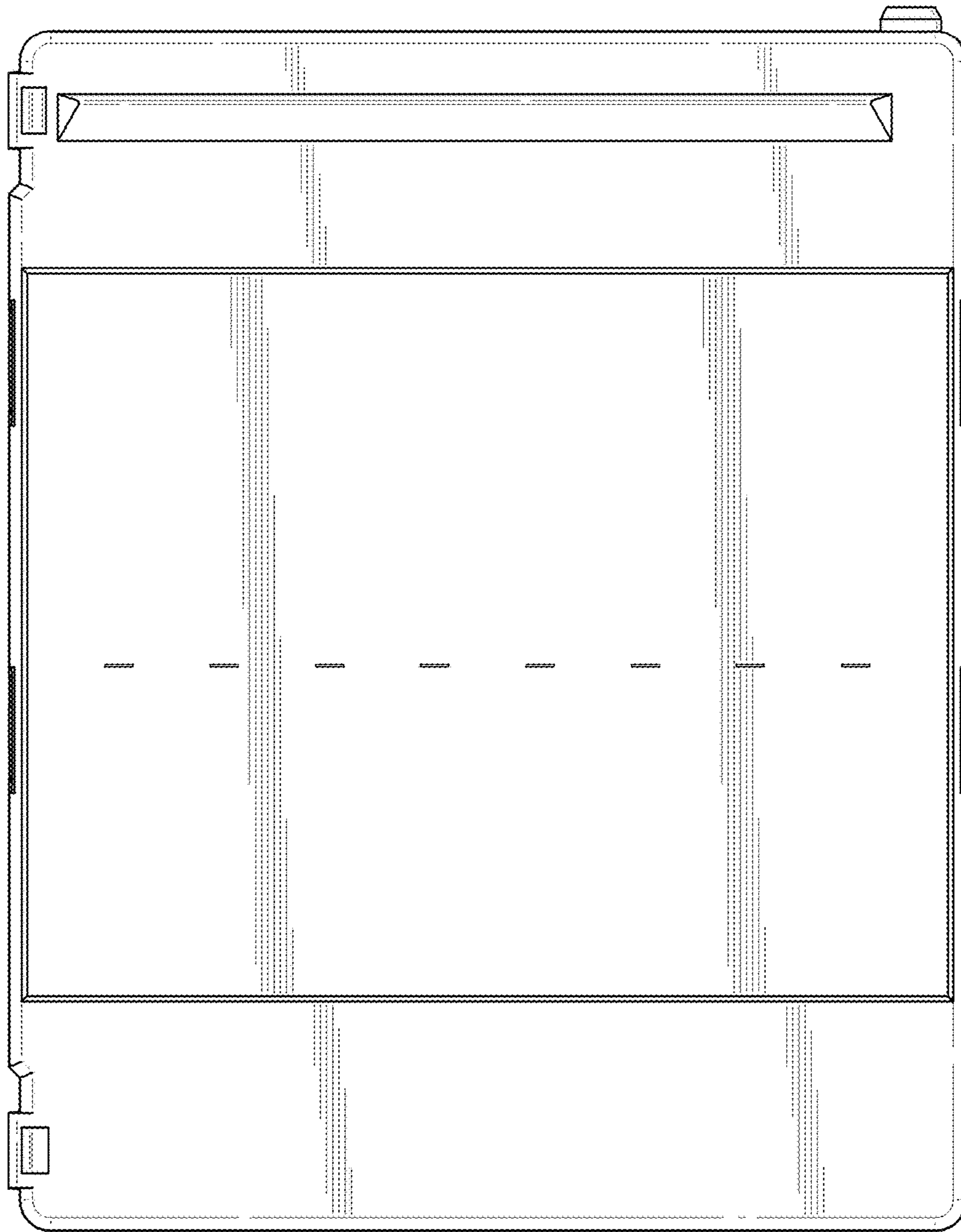

FIG. 18

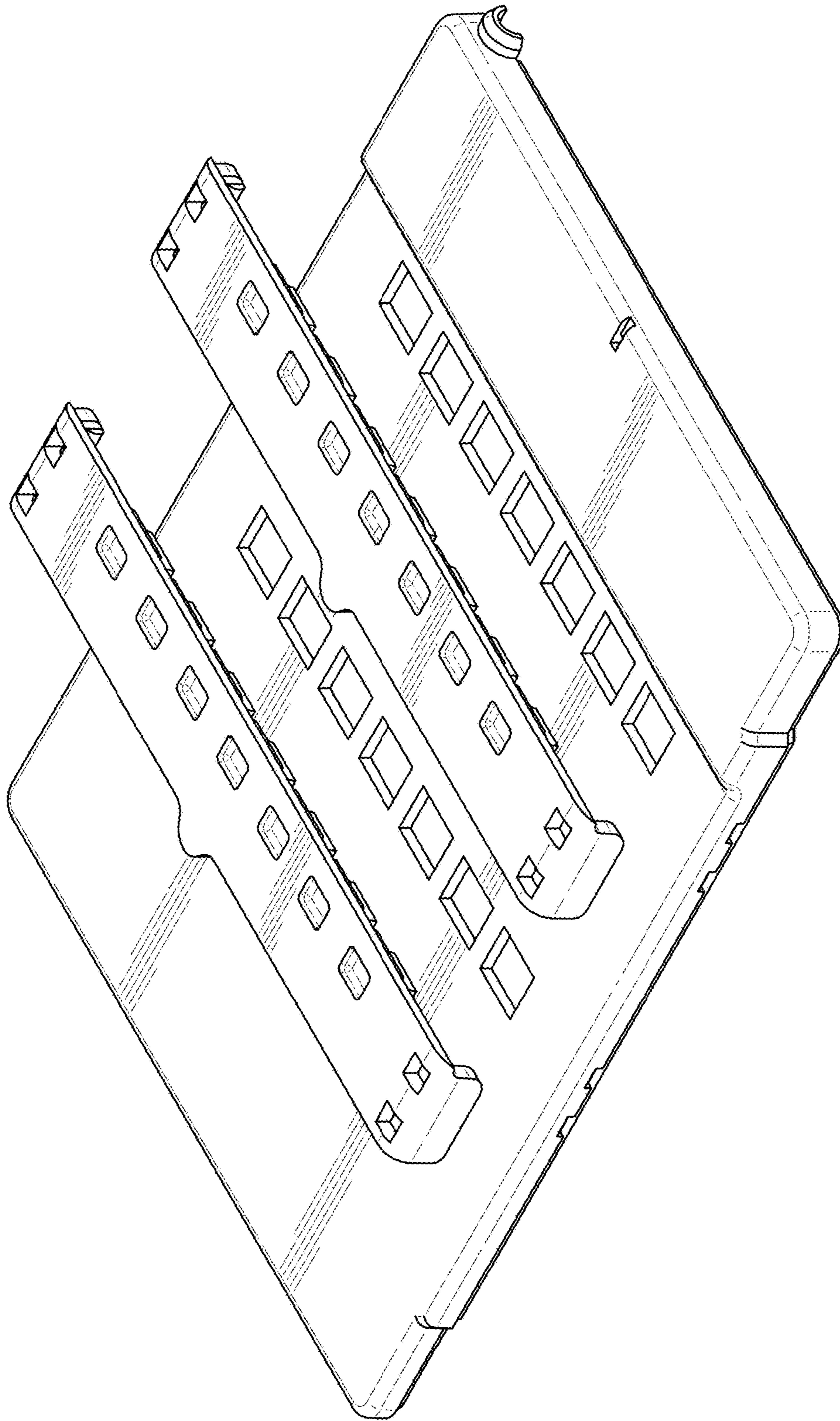

FIG. 19

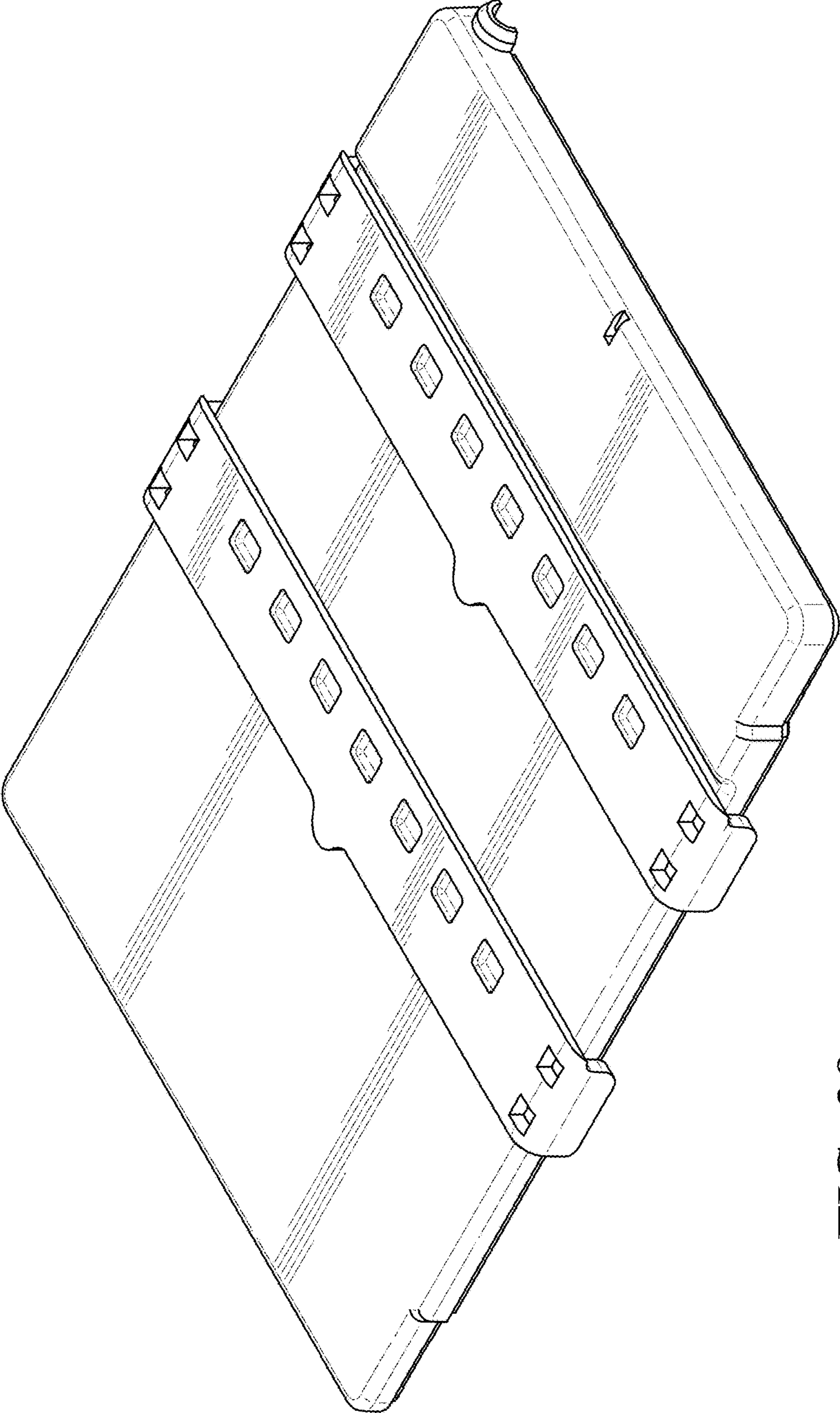

FIG. 20

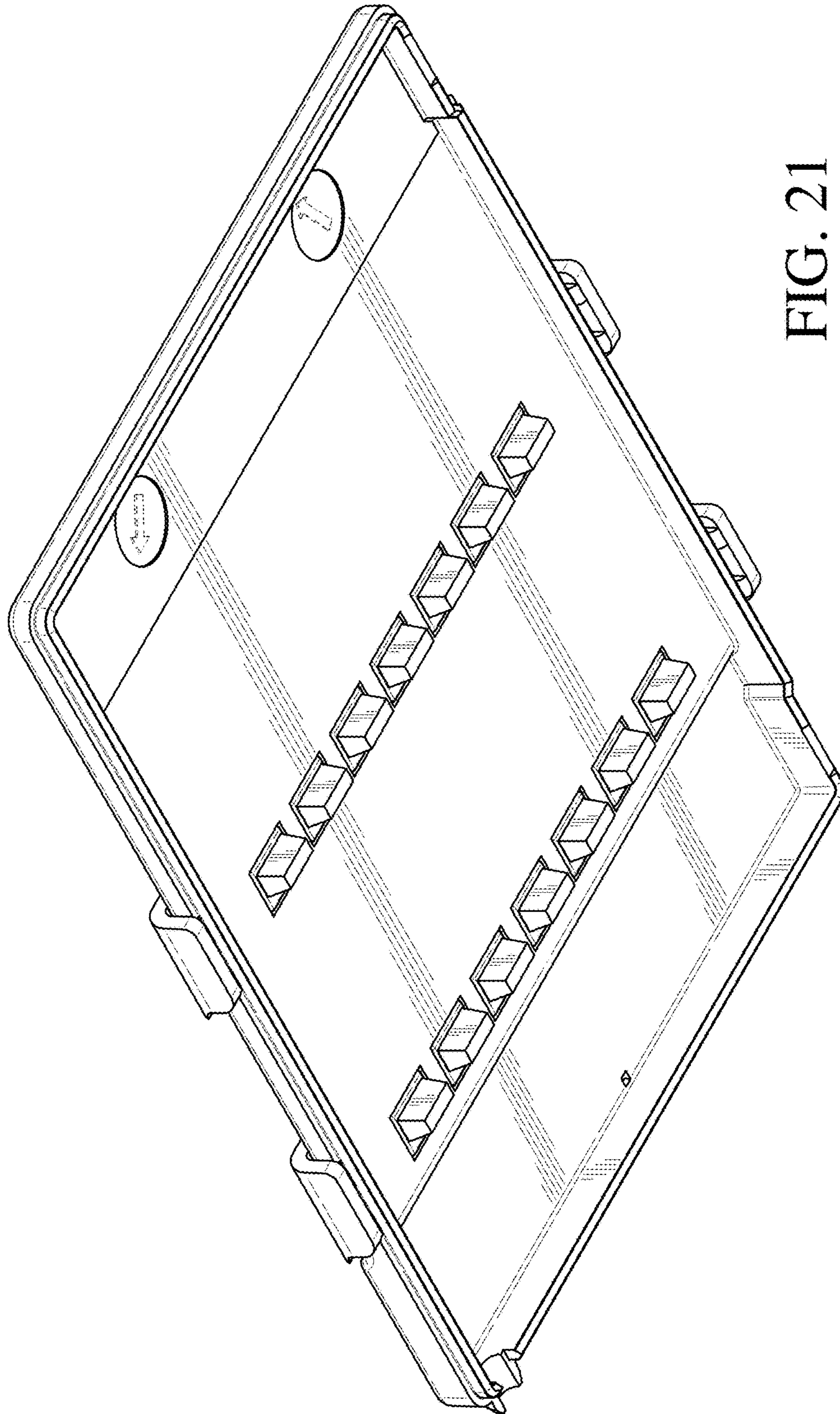

FIG. 21

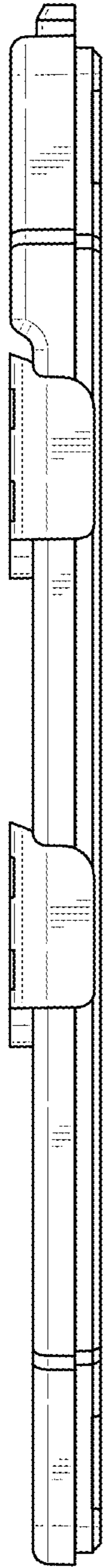

FIG. 22



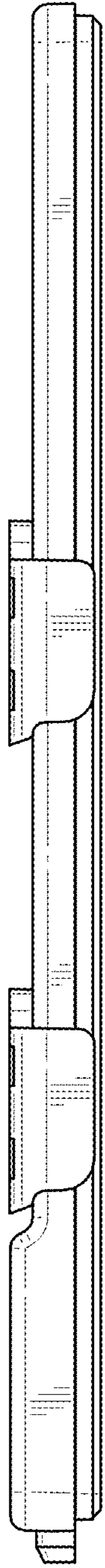

FIG. 23

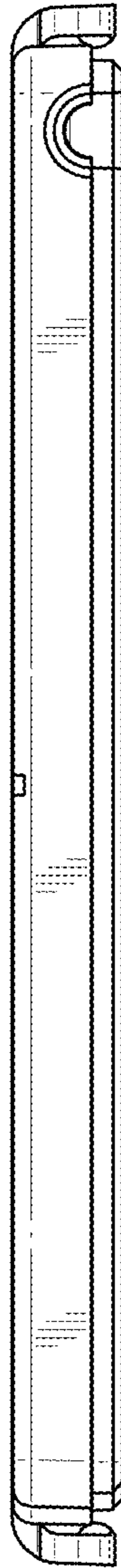

FIG. 24

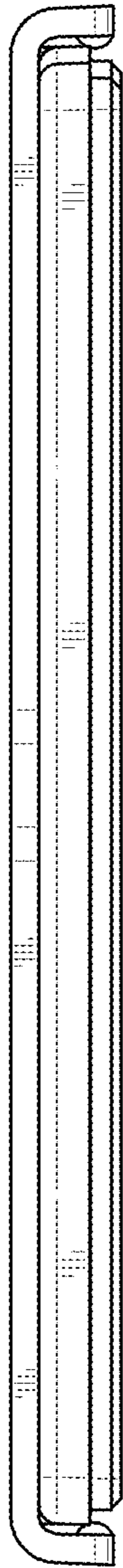

FIG. 25

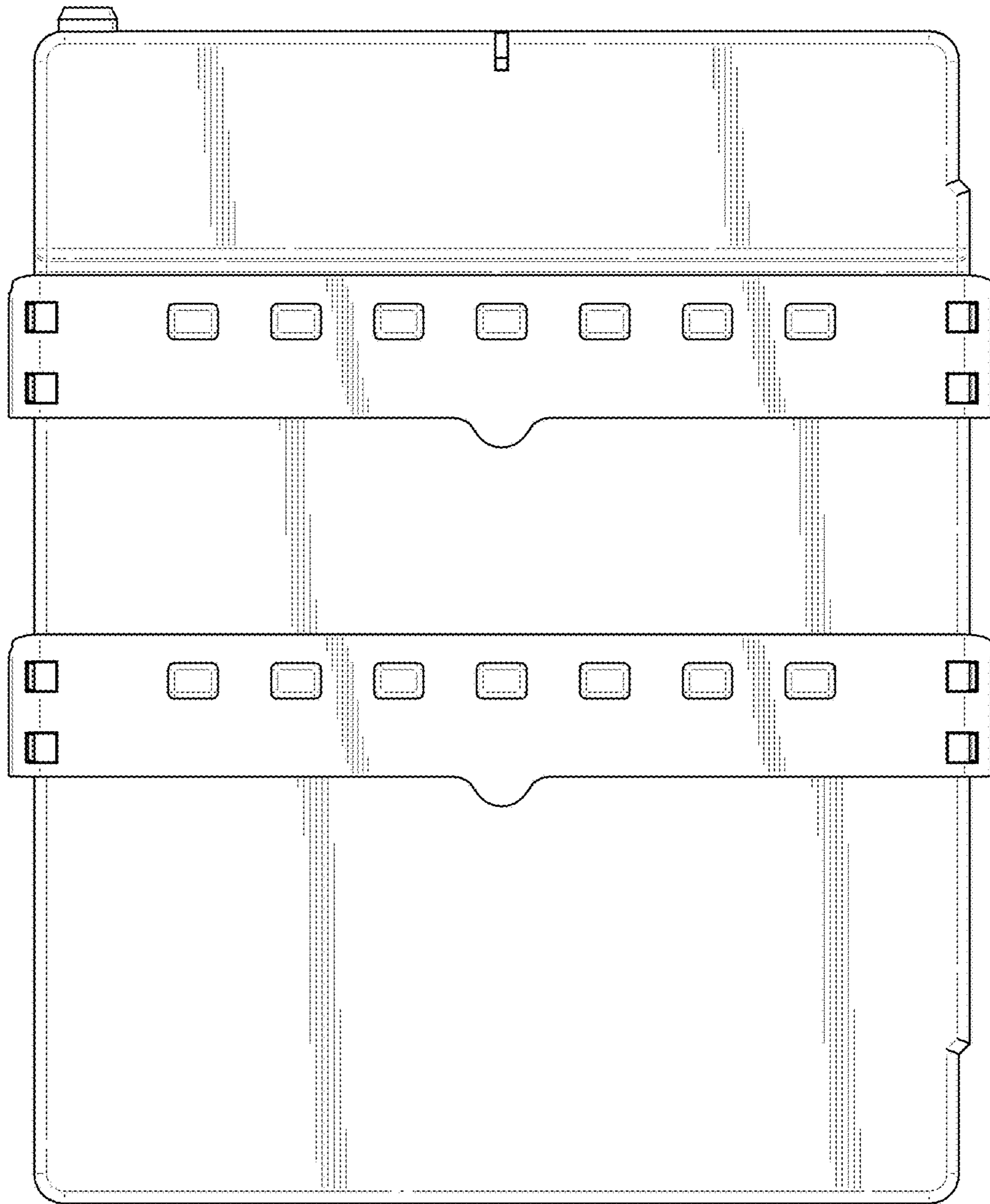

FIG. 26

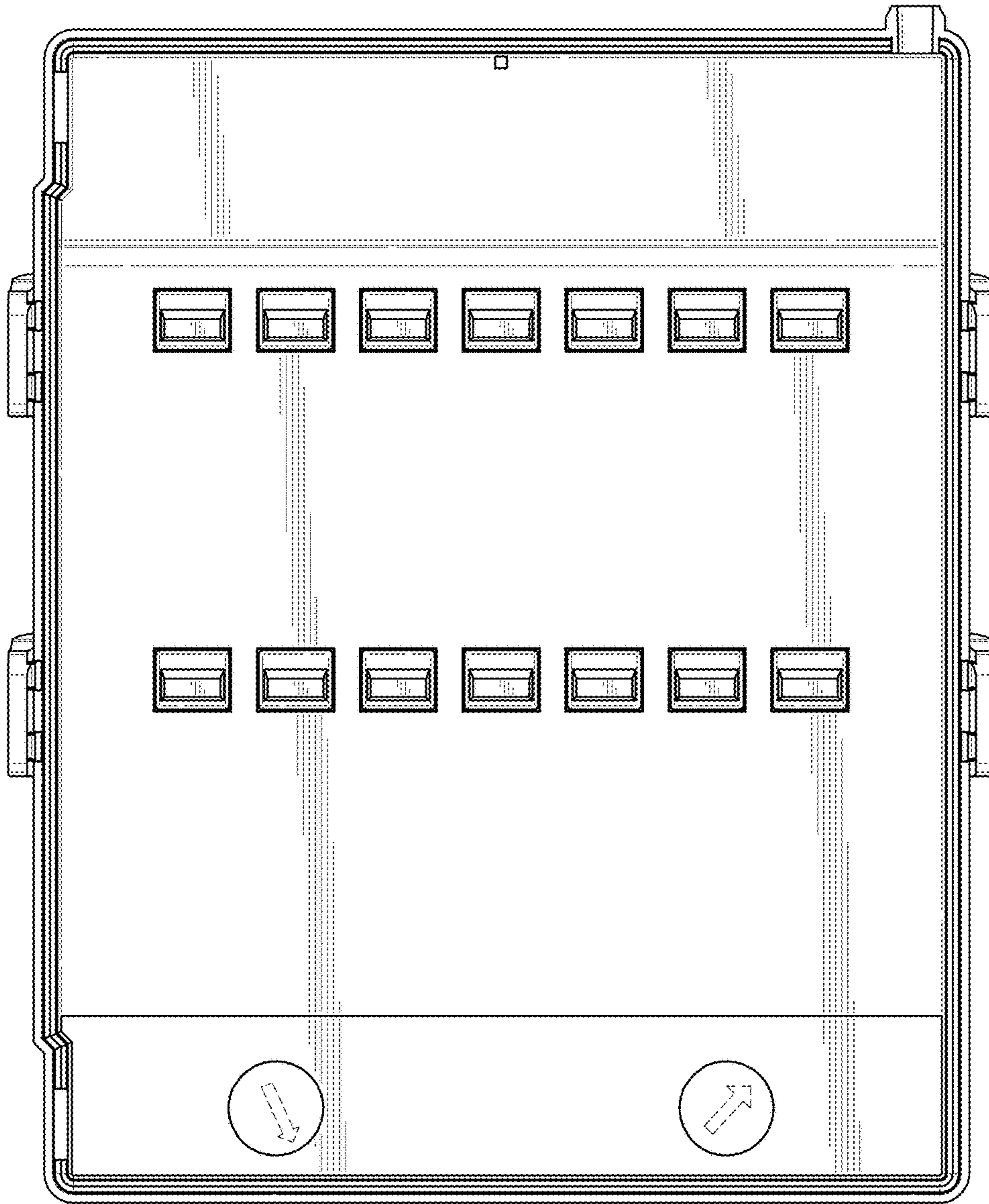

FIG. 27

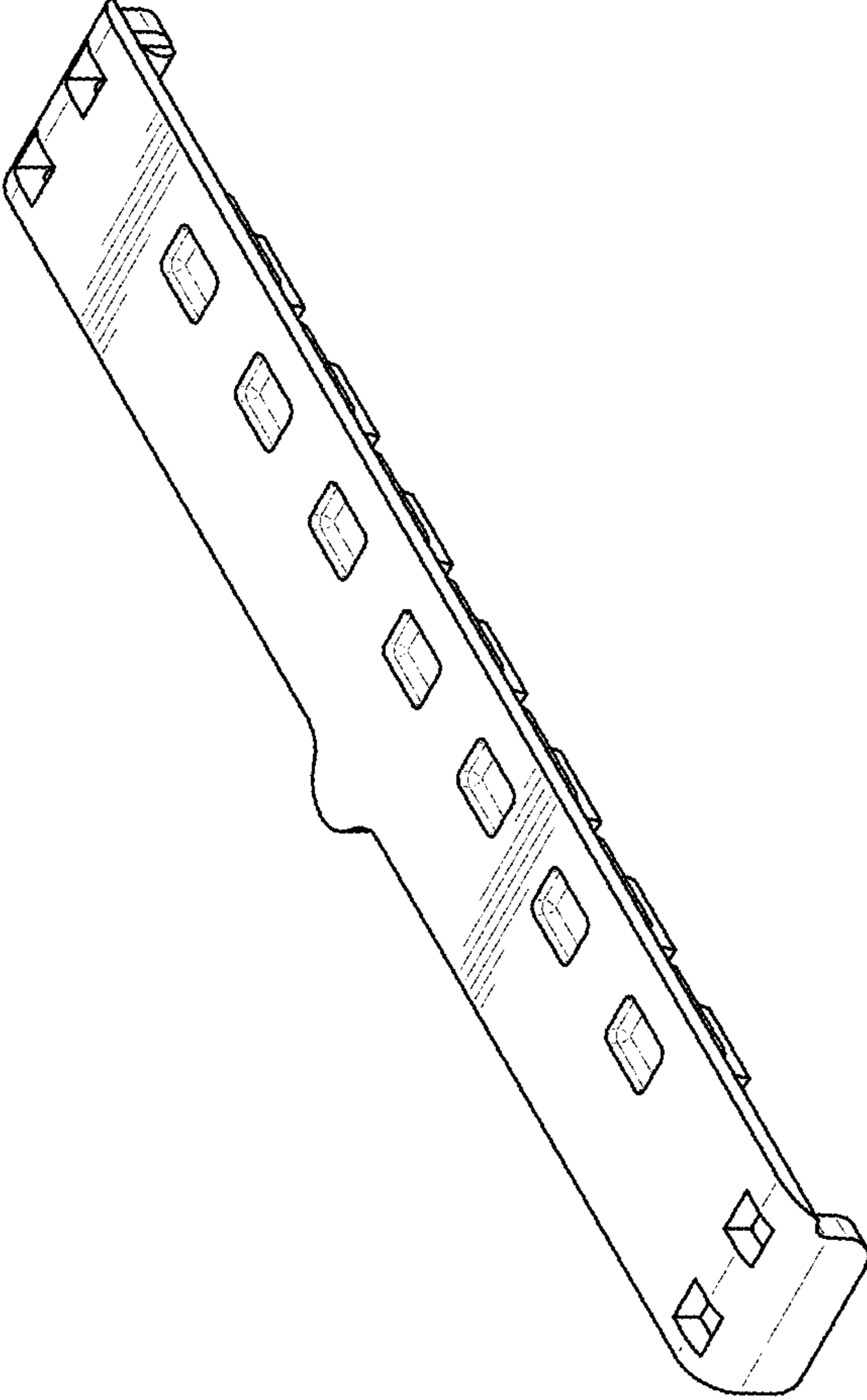

FIG. 28

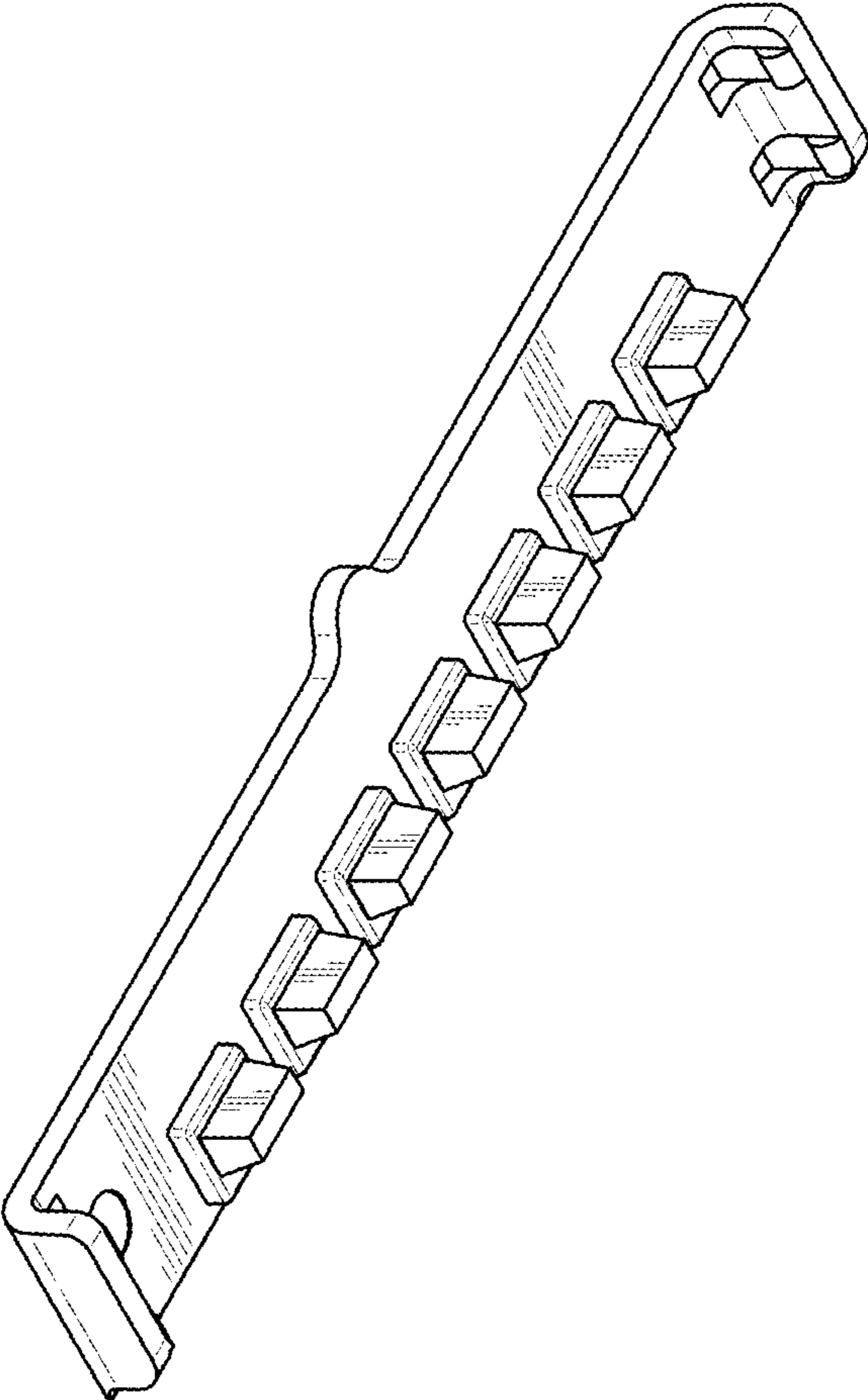

FIG. 29

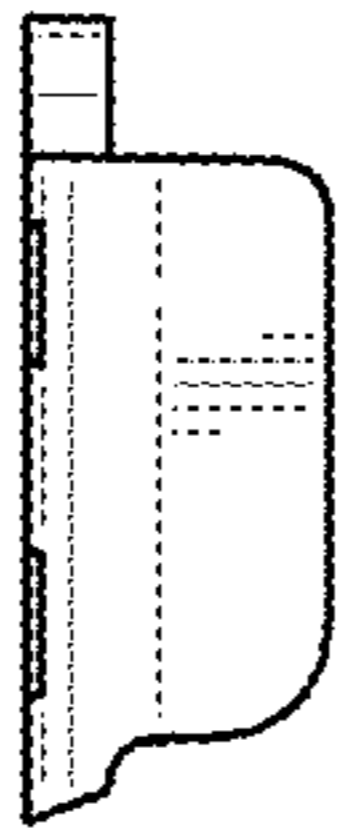

FIG. 31



FIG. 30



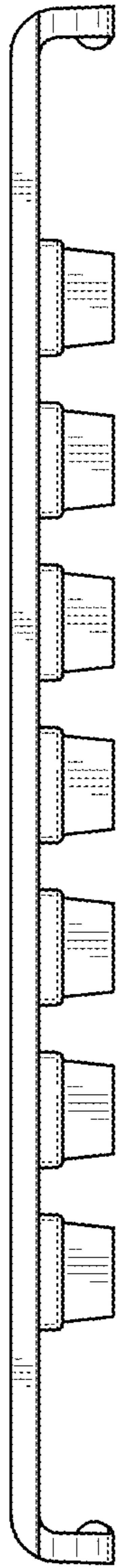

FIG. 32

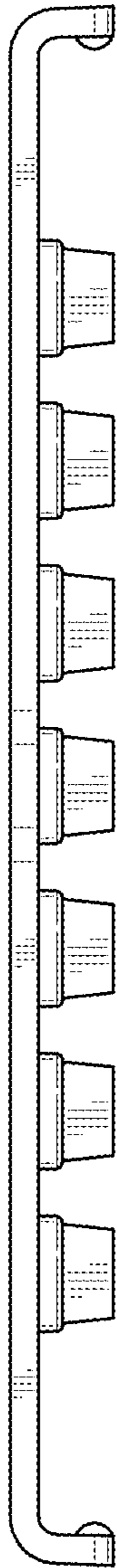

FIG. 33

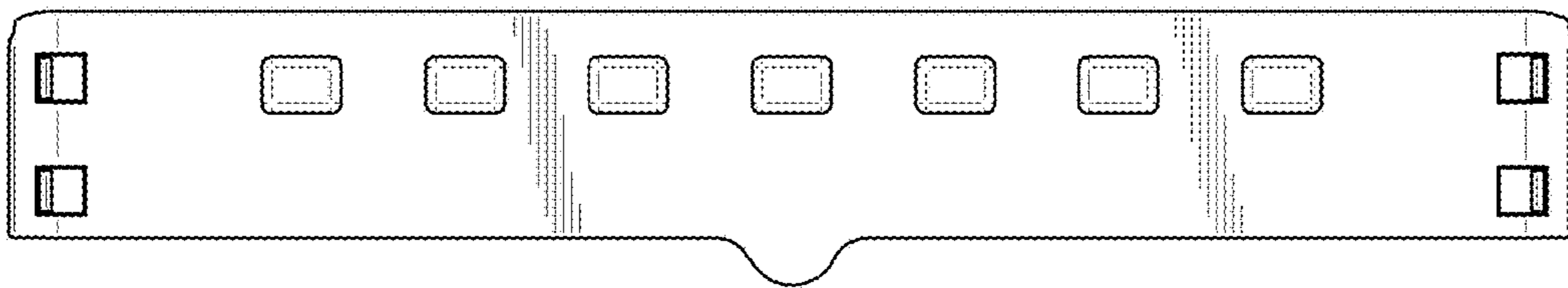

FIG. 34

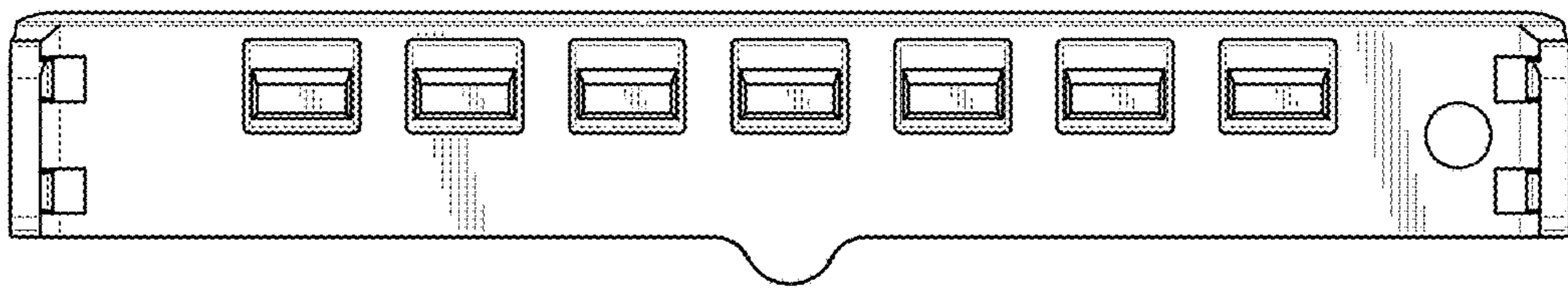

FIG. 35

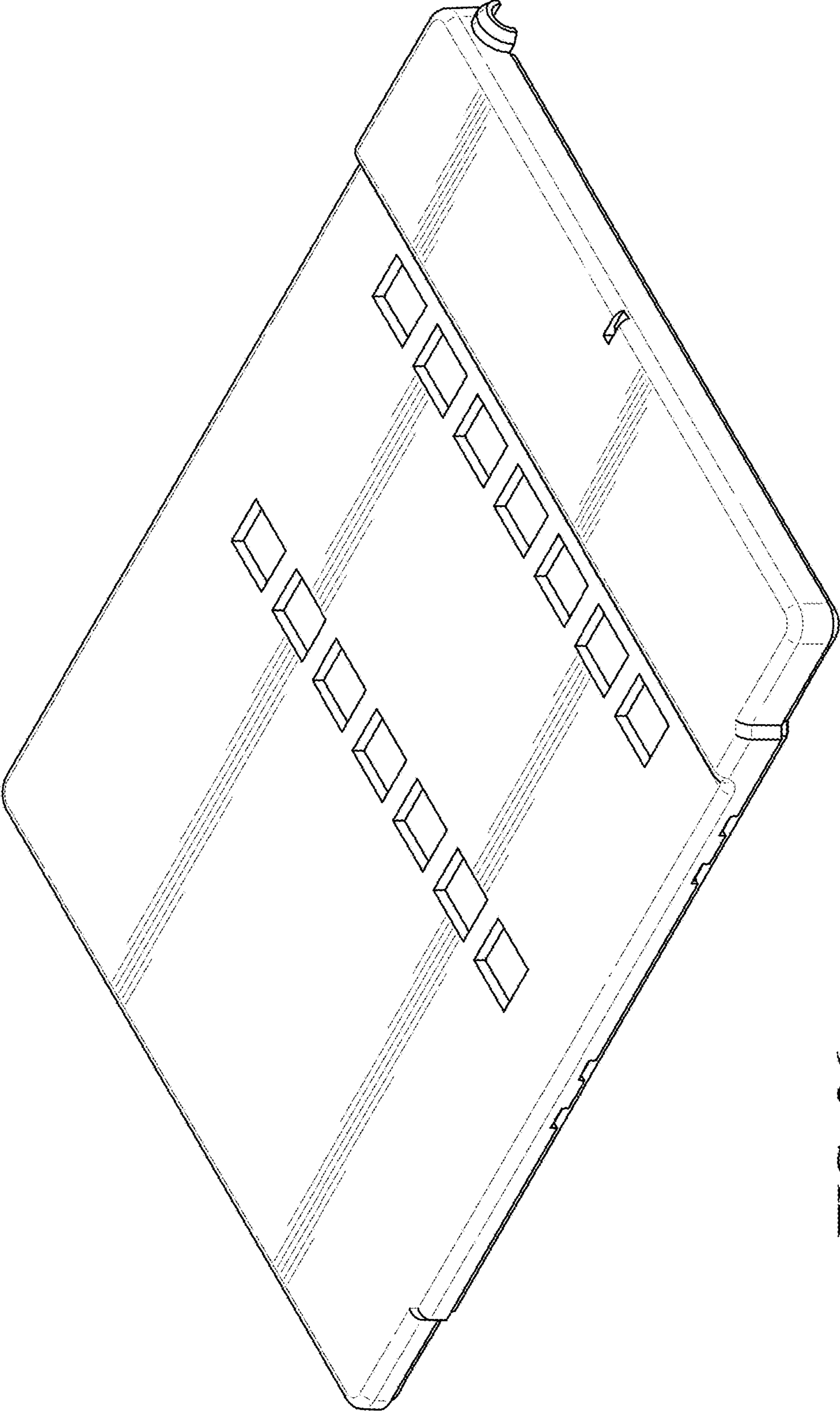

FIG. 36

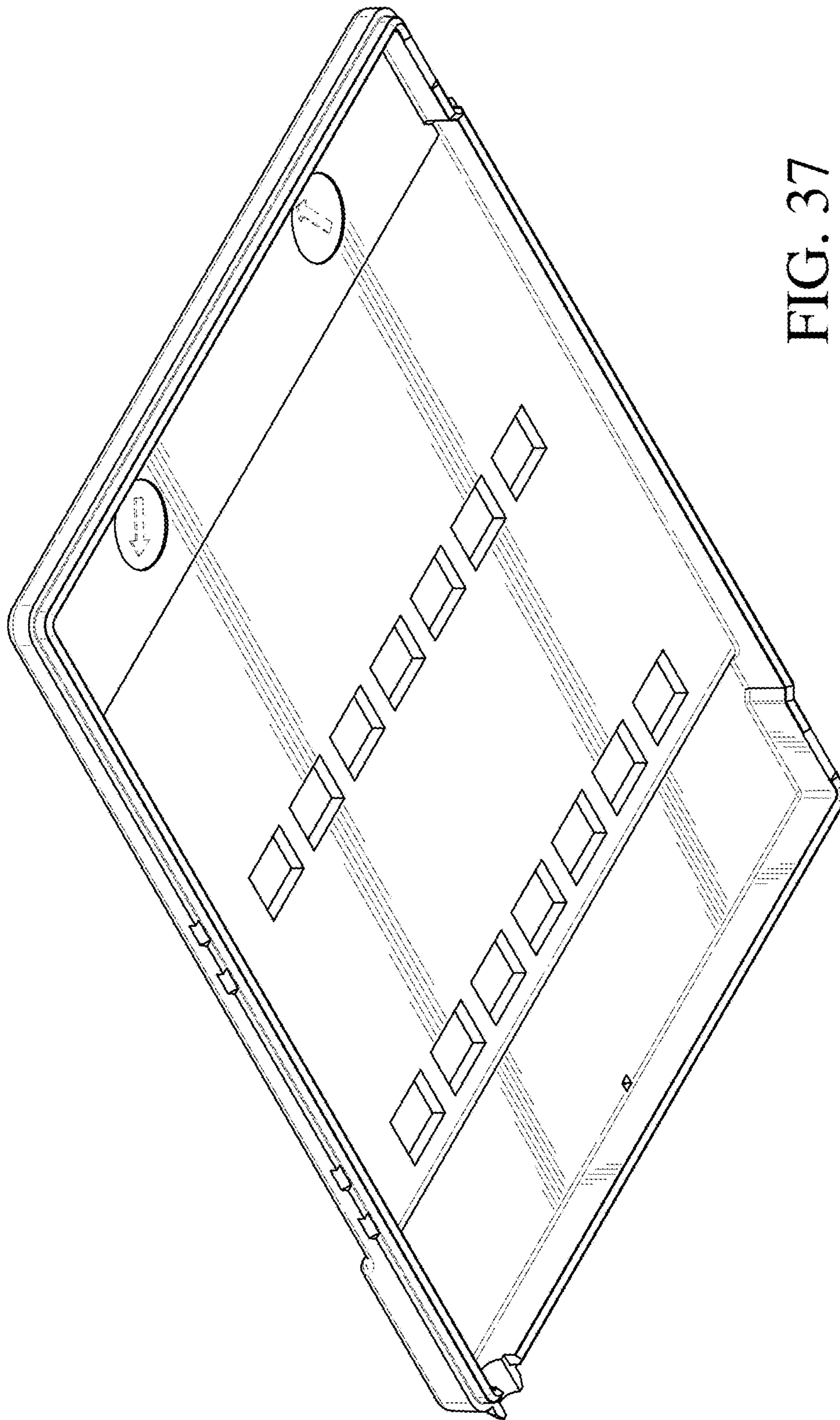

FIG. 37

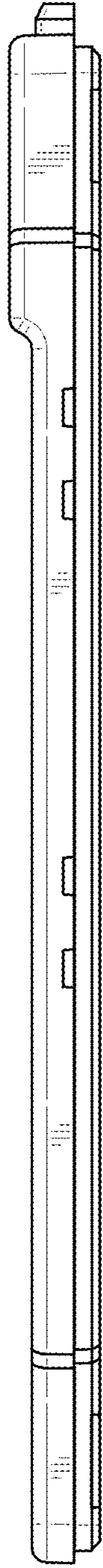

FIG. 38

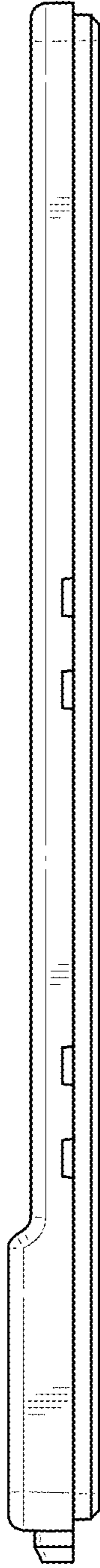

FIG. 39



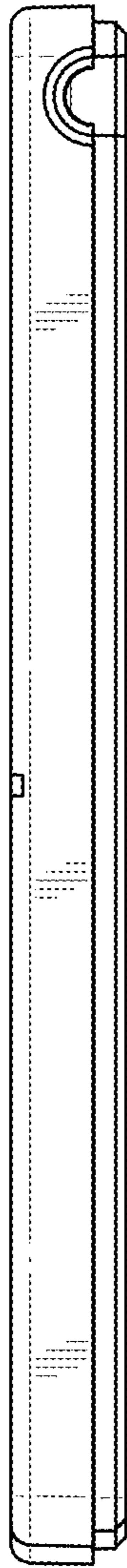

FIG. 40

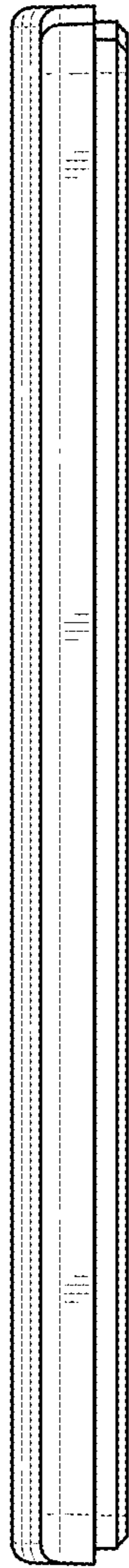

FIG. 41

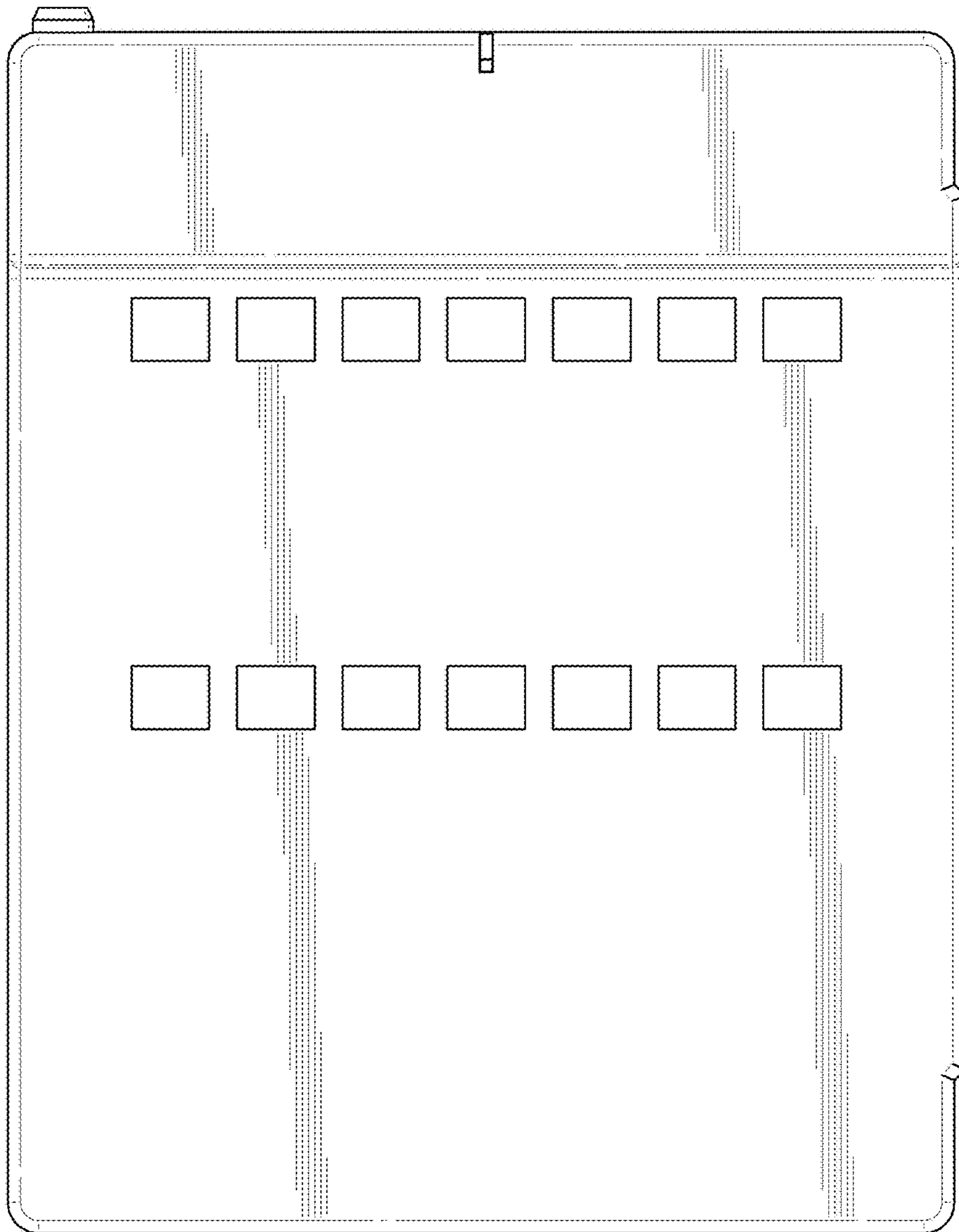

FIG. 42

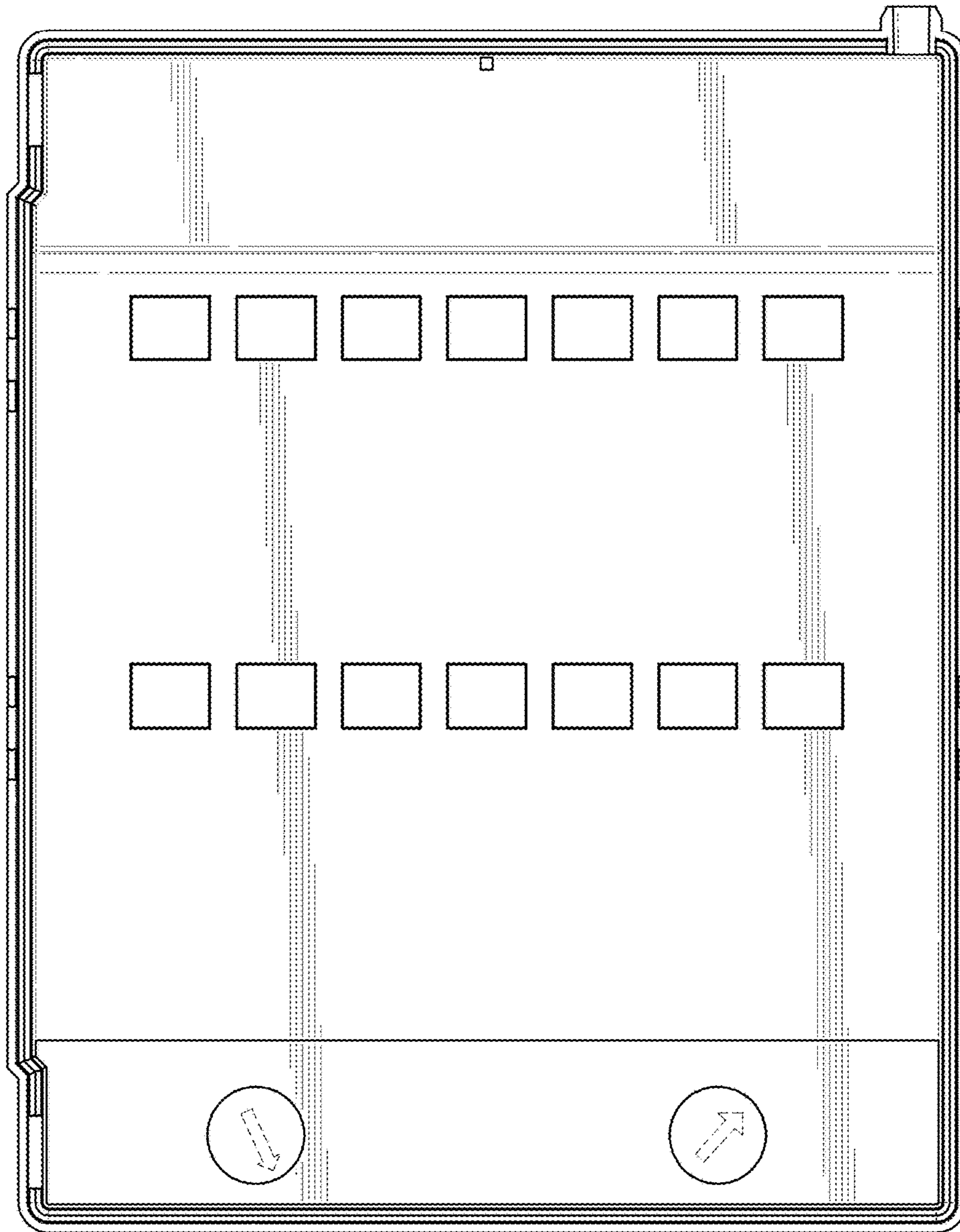

FIG. 43

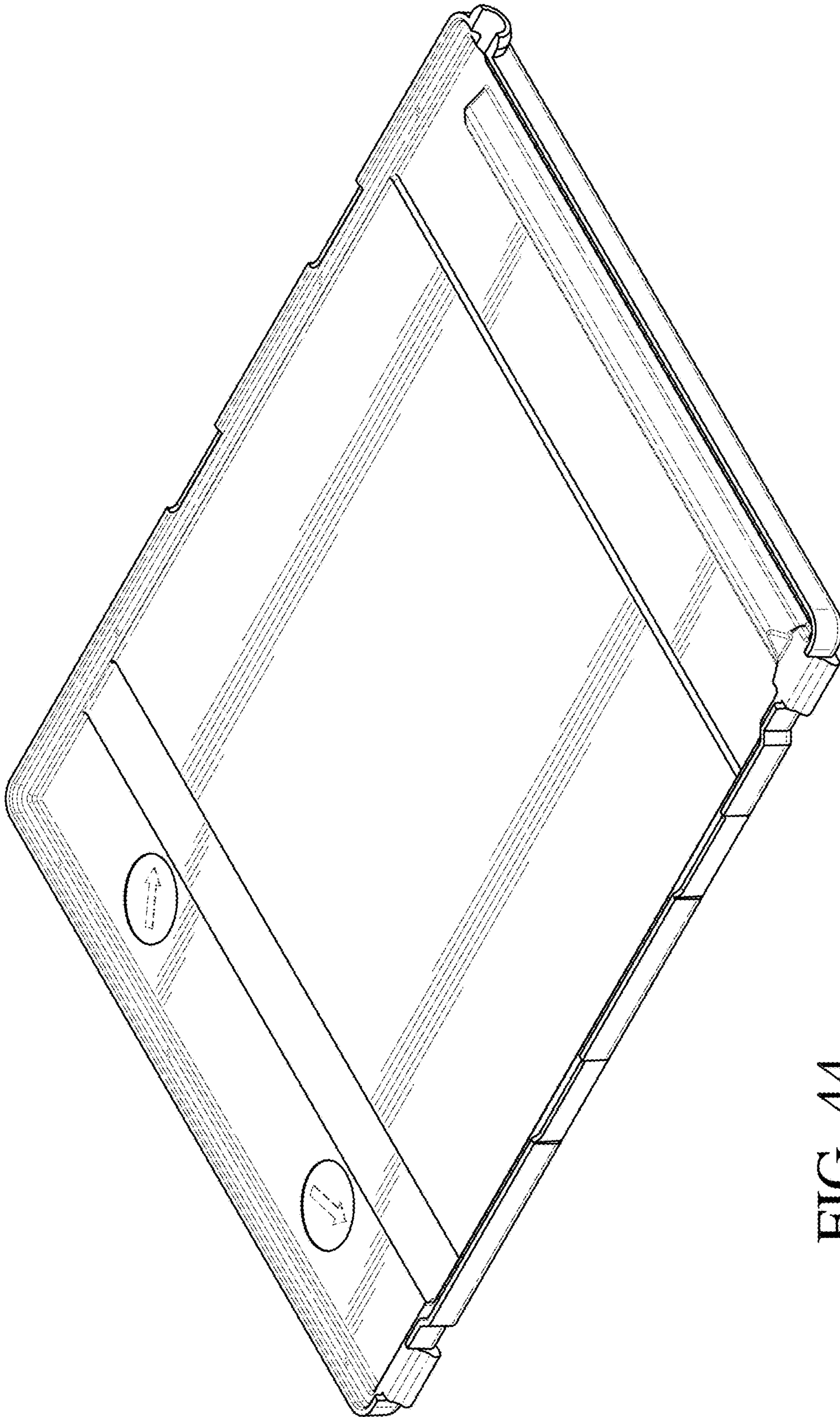

FIG. 44

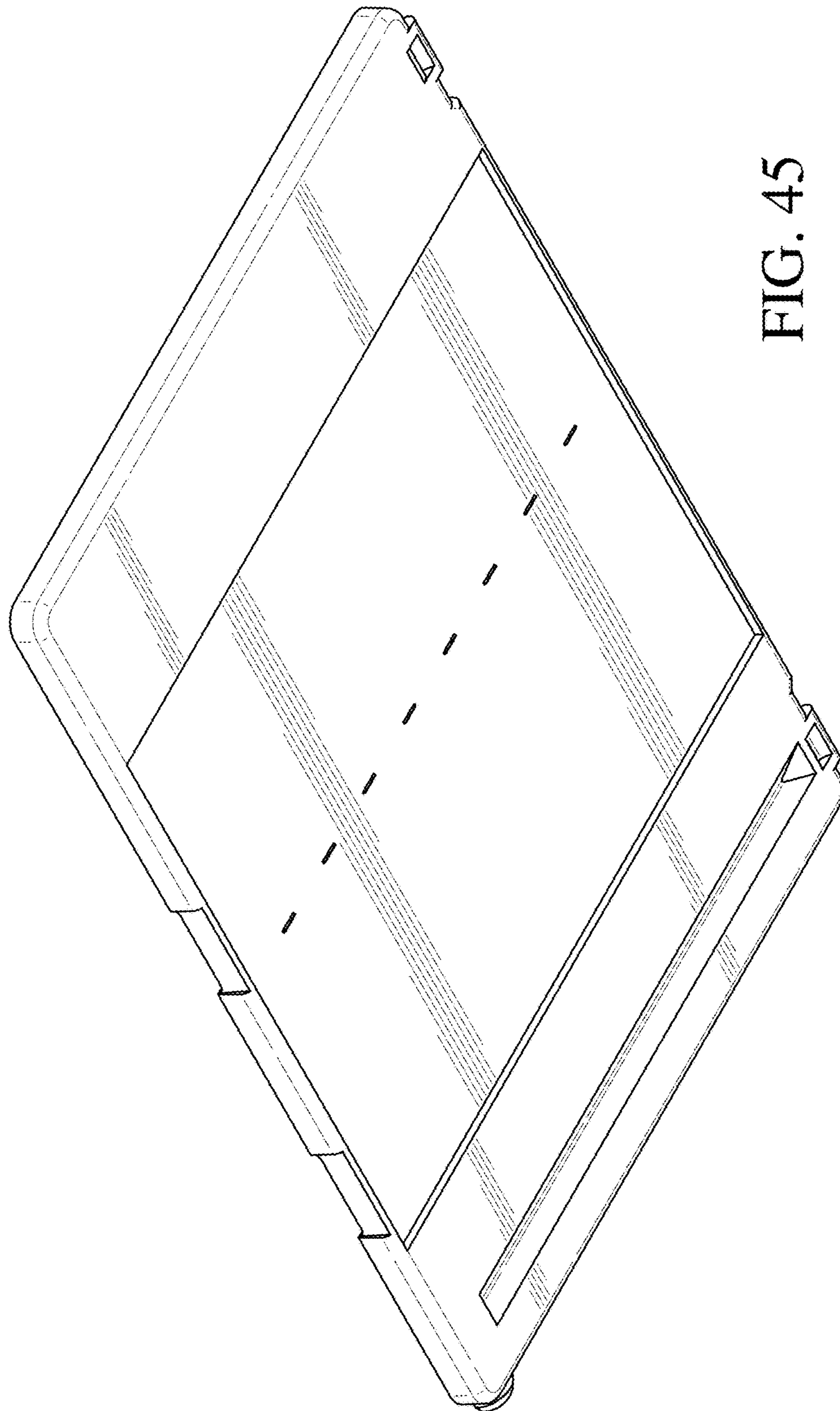

FIG. 45

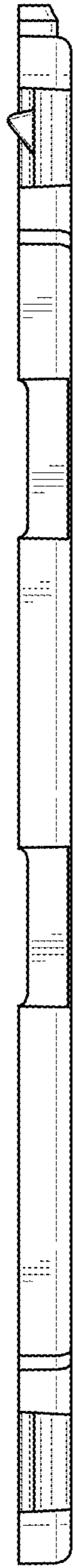

FIG. 46



FIG. 47



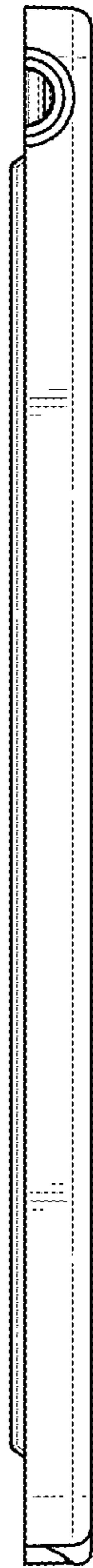

FIG. 48

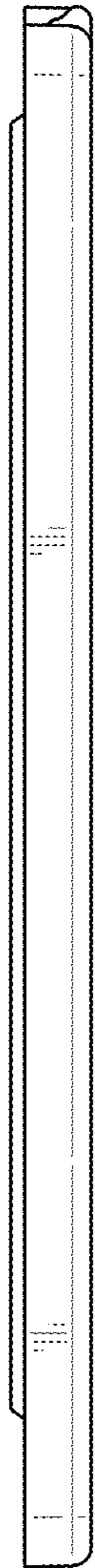

FIG. 49

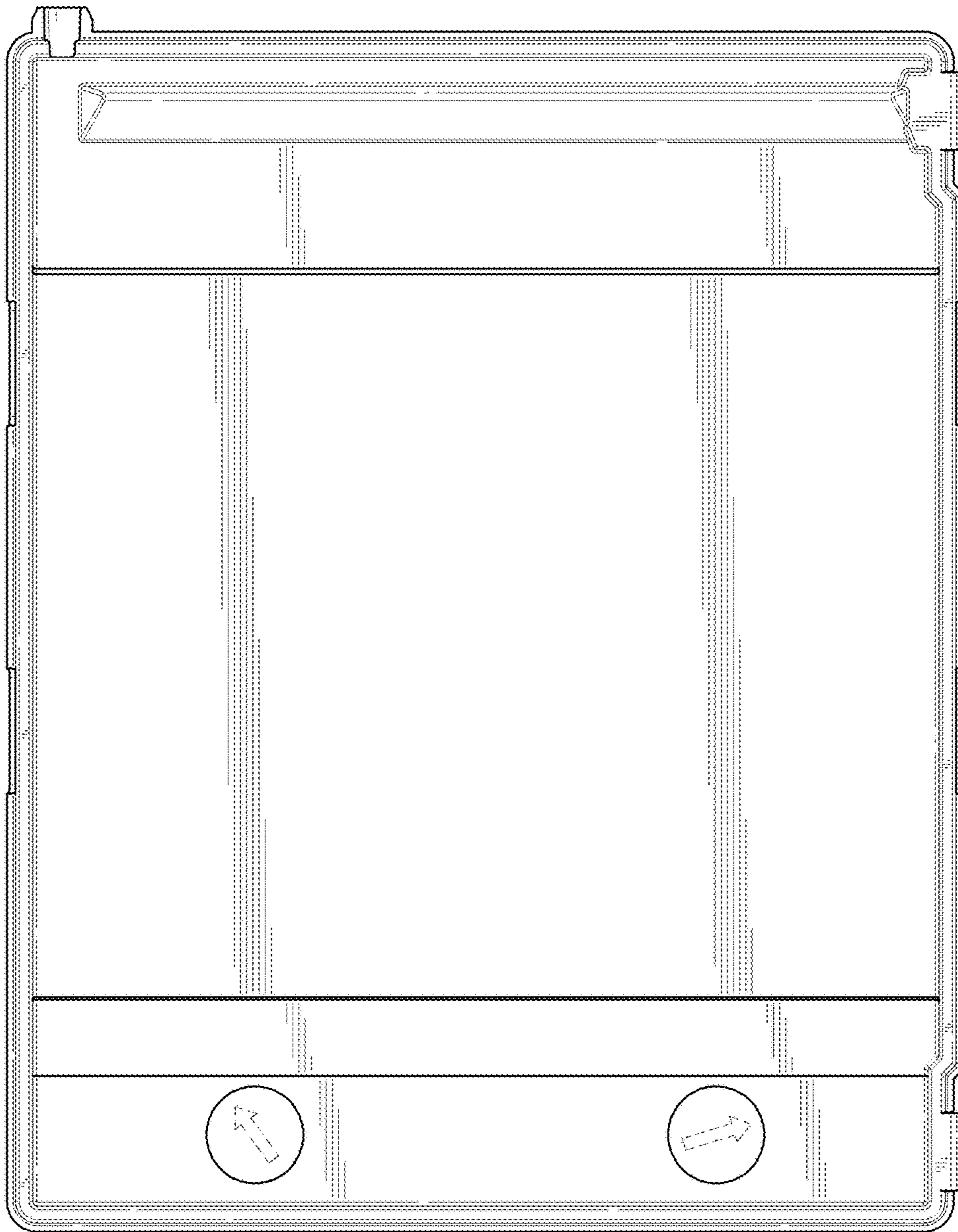

FIG. 50

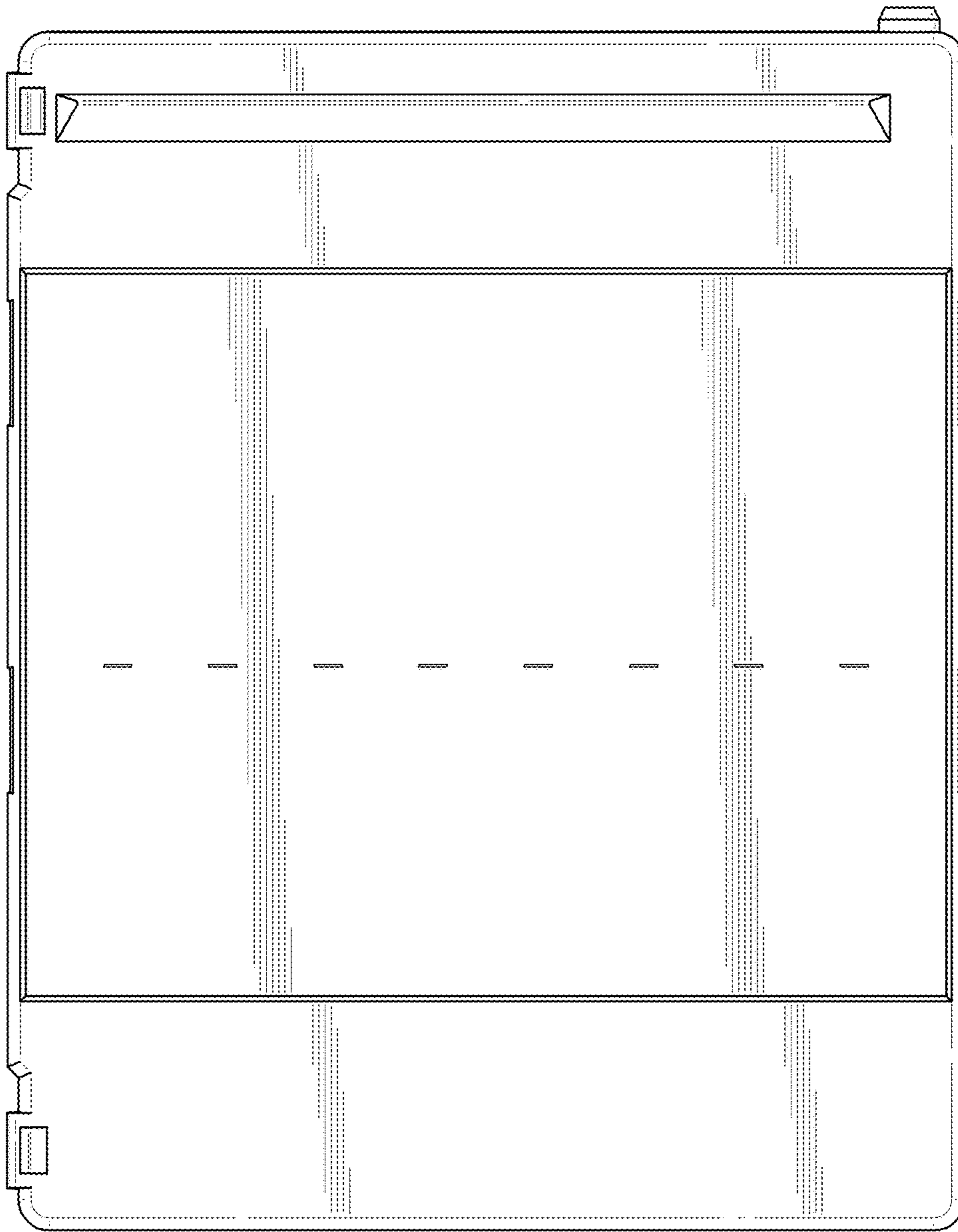

FIG. 51