



US00D860951S

(12) **United States Design Patent** (10) **Patent No.:** **US D860,951 S**
Hu (45) **Date of Patent:** **** Sep. 24, 2019**

(54) **CAR CHARGER**

(71) Applicant: **SHENZHEN QIANHAI PATUOXUN NETWORK AND TECHNOLOGY CO., LTD**, Shenzhen (CN)

(72) Inventor: **Zaihui Hu**, Shenzhen (CN)

(73) Assignee: **SHENZHEN QIANHAI PATUOXUN NETWORK AND TECHNOLOGY CO., LTD**, Shenzhen (CN)

(**) Term: **15 Years**

(21) Appl. No.: **29/680,626**

(22) Filed: **Feb. 19, 2019**

(51) **LOC (12) Cl.** **13-03**

(52) **U.S. Cl.**
USPC **D13/144; D13/108**

(58) **Field of Classification Search**
USPC D13/107-110, 118-119, 184, 199, 144;
D14/251, 253, 432, 434
CPC Y02E 60/12; Y02T 90/14; Y02T 90/122;
Y02T 90/128; Y02T 90/163; Y02T
10/7005; Y02T 10/7088; H02J 7/025;
H02J 7/0042; H02J 7/0044; H02J 7/0045;
H02J 7/0003; H02J 7/02; H01F 38/14;
H01M 2/1022; H01M 2/1055; H01M
10/44; H01M 10/46; H01M 10/425; B60L
11/182; H01R 24/58; H01R 13/6675;
H01R 2201/26; B60N 3/14; B60R
2011/0054

See application file for complete search history.

(56) **References Cited**

U.S. PATENT DOCUMENTS

D418,213 S * 12/1999 Colandro D23/366
D525,937 S * 8/2006 Seil D13/144

D569,342 S * 5/2008 Suzuki D13/110
D604,699 S * 11/2009 Yamamoto D13/108
D607,852 S * 1/2010 Riede D13/171
D635,923 S * 4/2011 Lin D13/144
D652,384 S * 1/2012 Lee D13/144
D700,572 S * 3/2014 Esses D13/108
8,784,137 B2 * 7/2014 Yang H01H 85/542
439/620.28
D807,289 S * 1/2018 Wang D13/107

FOREIGN PATENT DOCUMENTS

CN 304992313 1/2019
EM 003418631-0001 12/2016

* cited by examiner

Primary Examiner — Rosemary K Tarcza

(74) *Attorney, Agent, or Firm* — JCIP Global Inc.

(57) **CLAIM**

The ornamental design for a car charger, as shown and described.

DESCRIPTION

FIG. 1 is a perspective view of a car charger showing my new design;
FIG. 2 is another perspective view thereof;
FIG. 3 is a front view thereof;
FIG. 4 is a rear view thereof;
FIG. 5 is a left side view thereof;
FIG. 6 is a right side view thereof;
FIG. 7 is a top view thereof; and,
FIG. 8 is a bottom view thereof.

The broken lines shown in the drawings represent portions of the car charger that form no part of the claimed design.

1 Claim, 7 Drawing Sheets

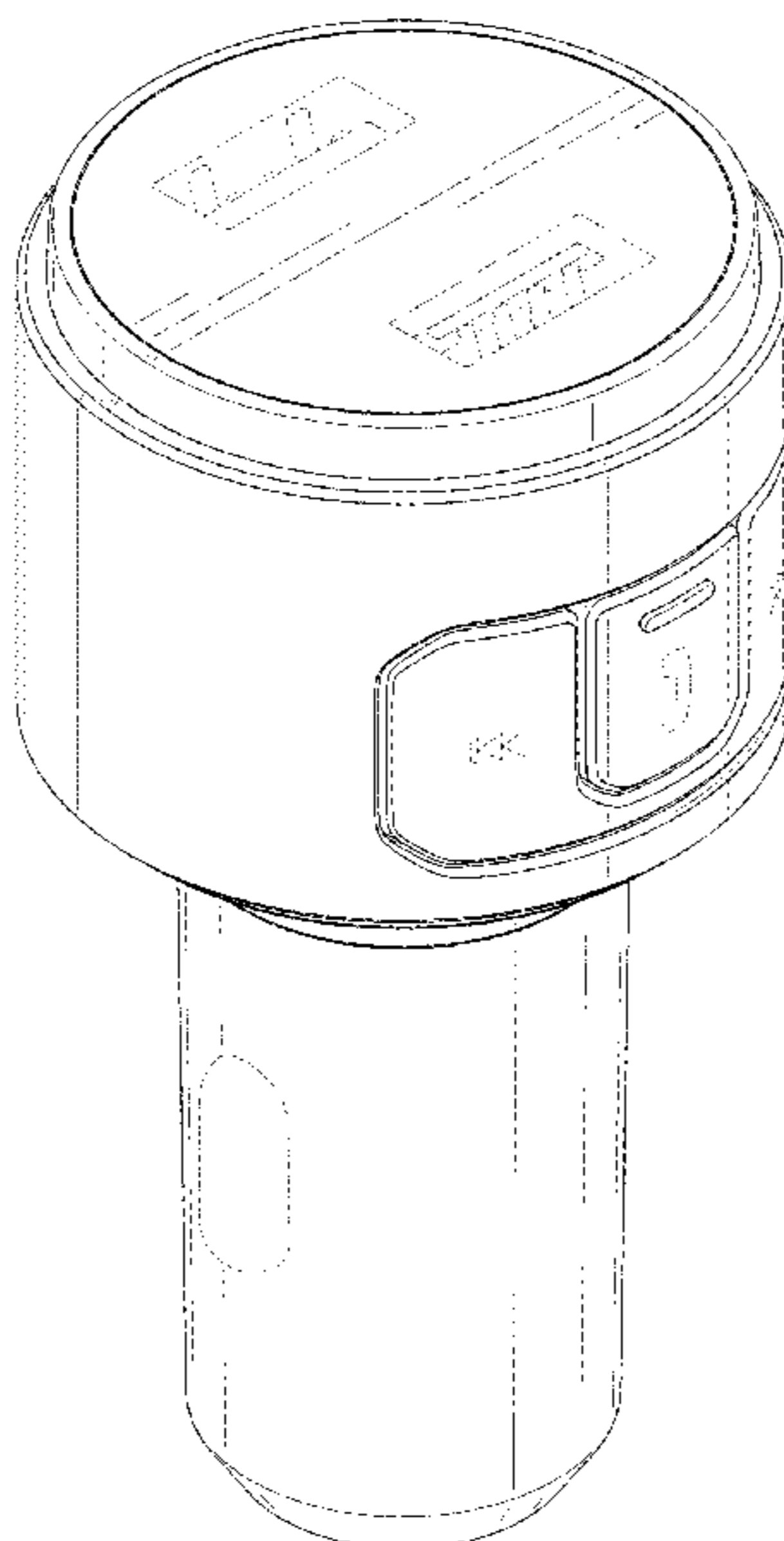

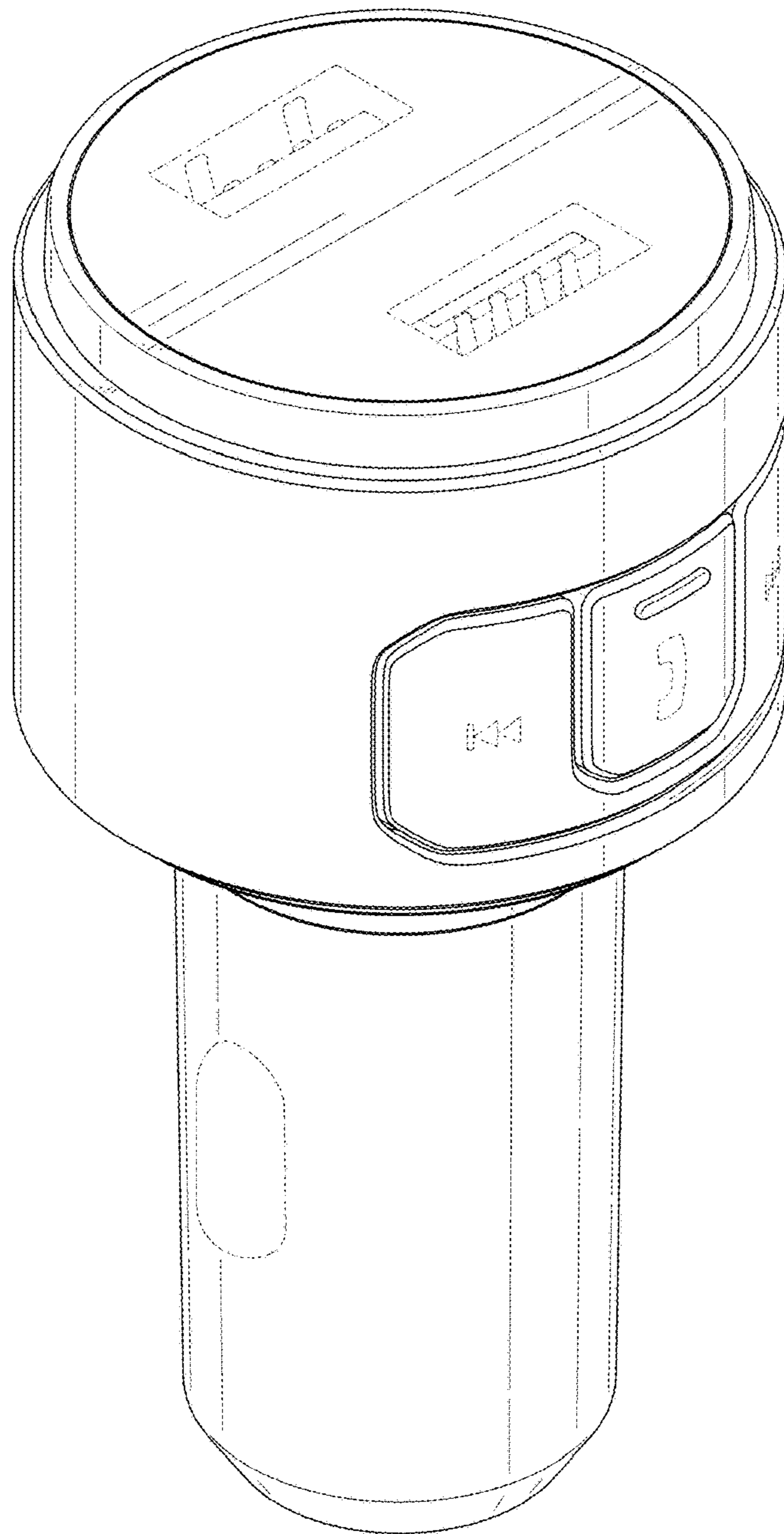

FIG. 1

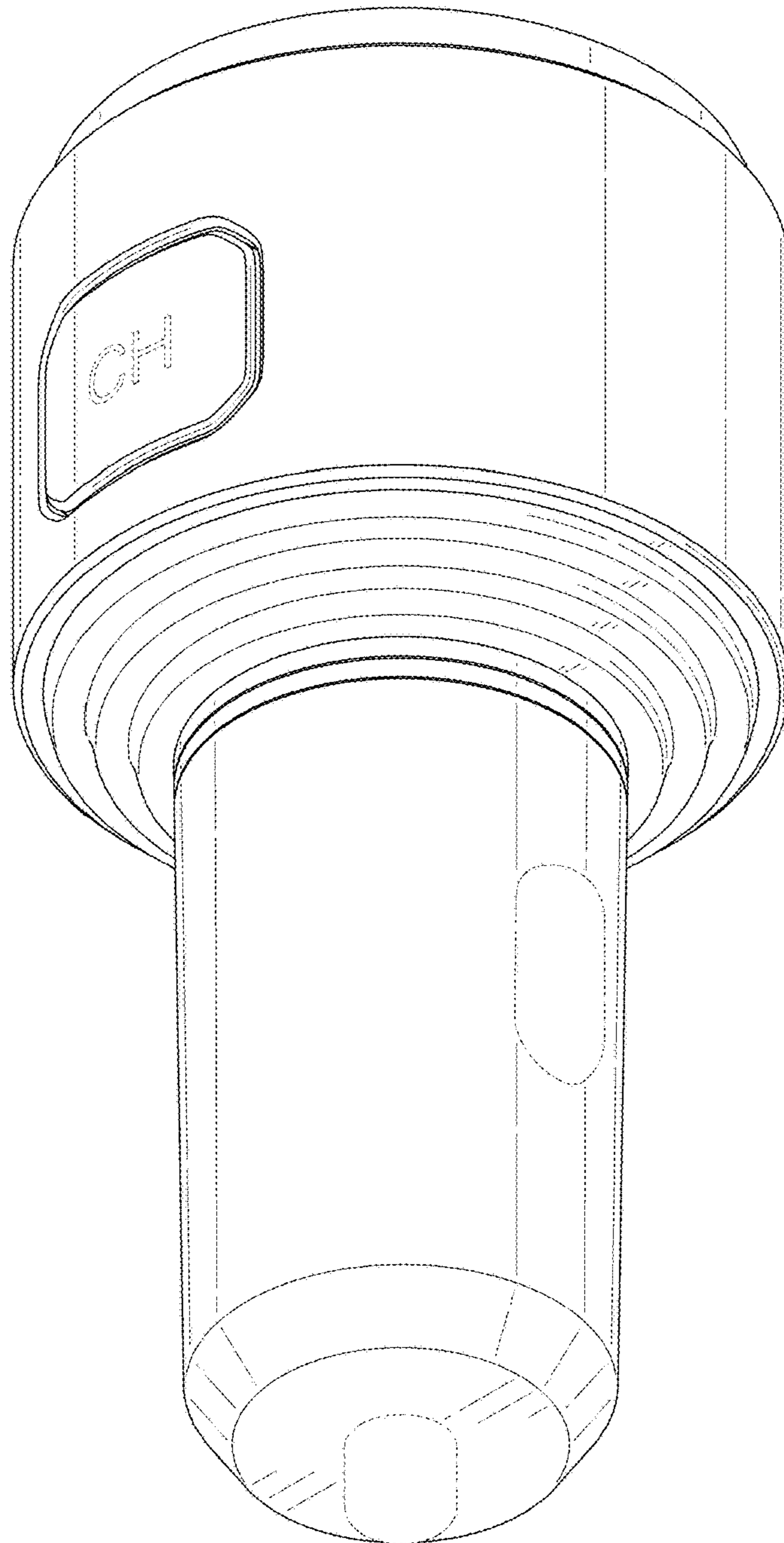

FIG. 2

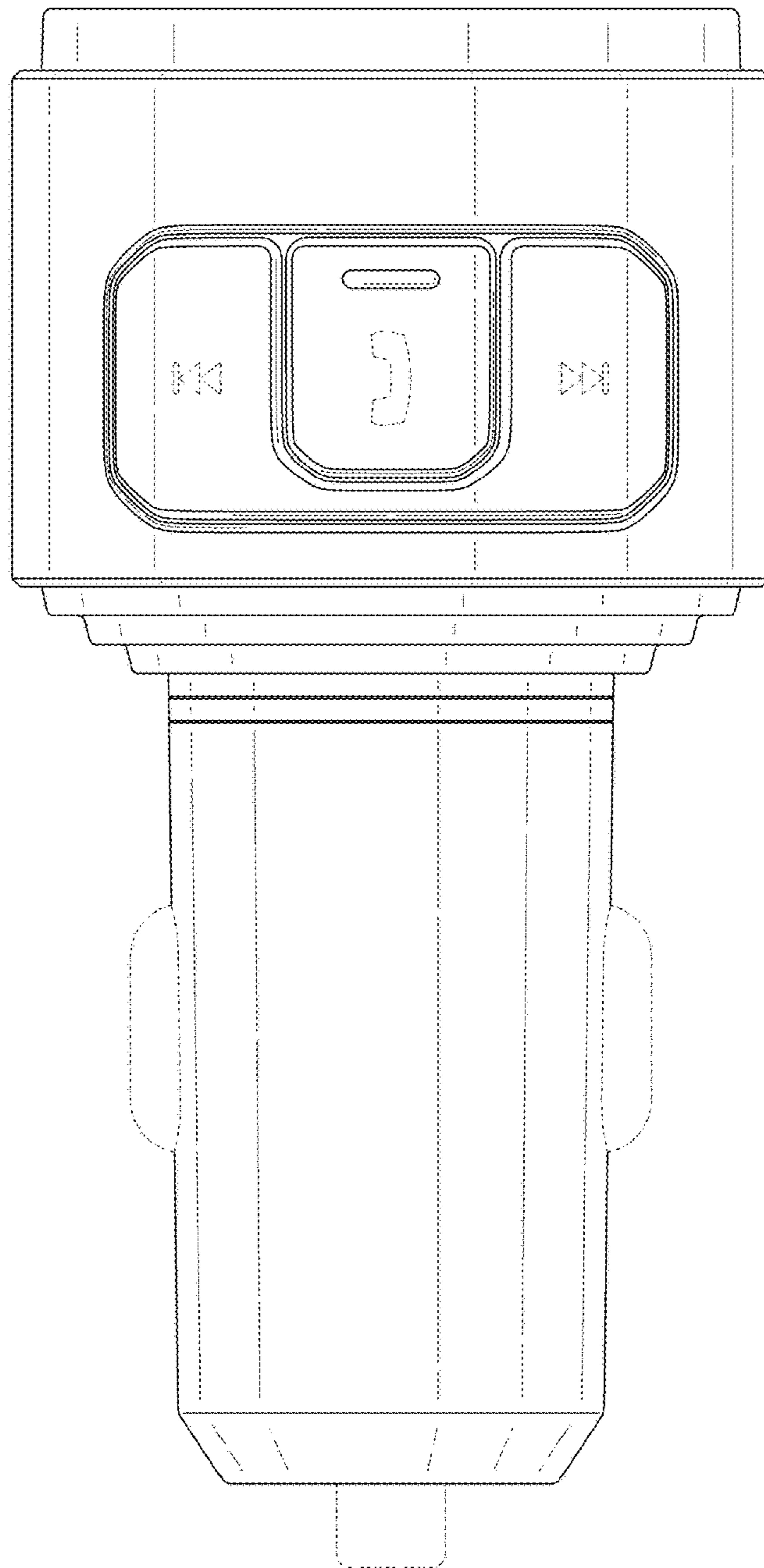

FIG. 3

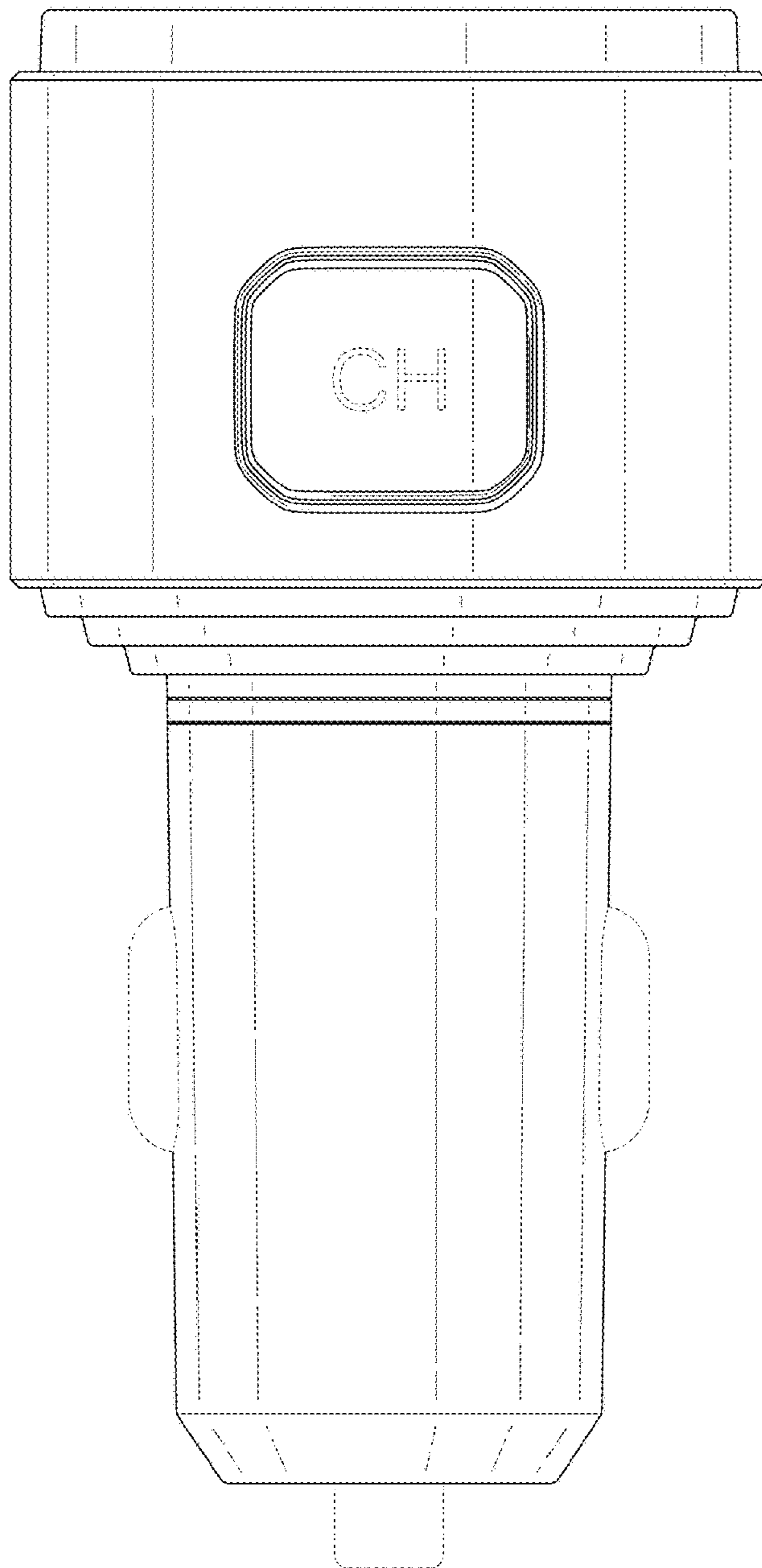

FIG. 4

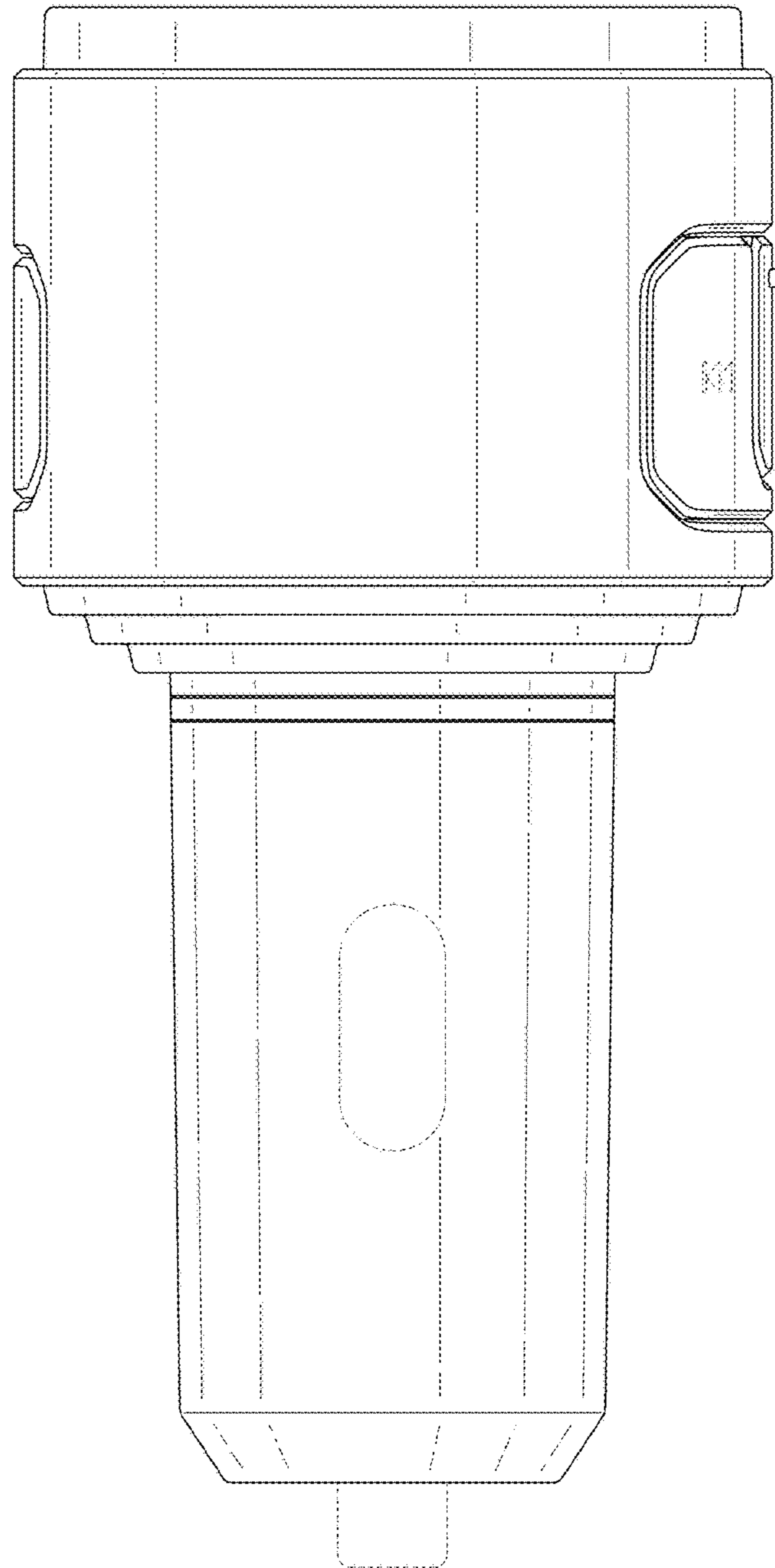

FIG. 5

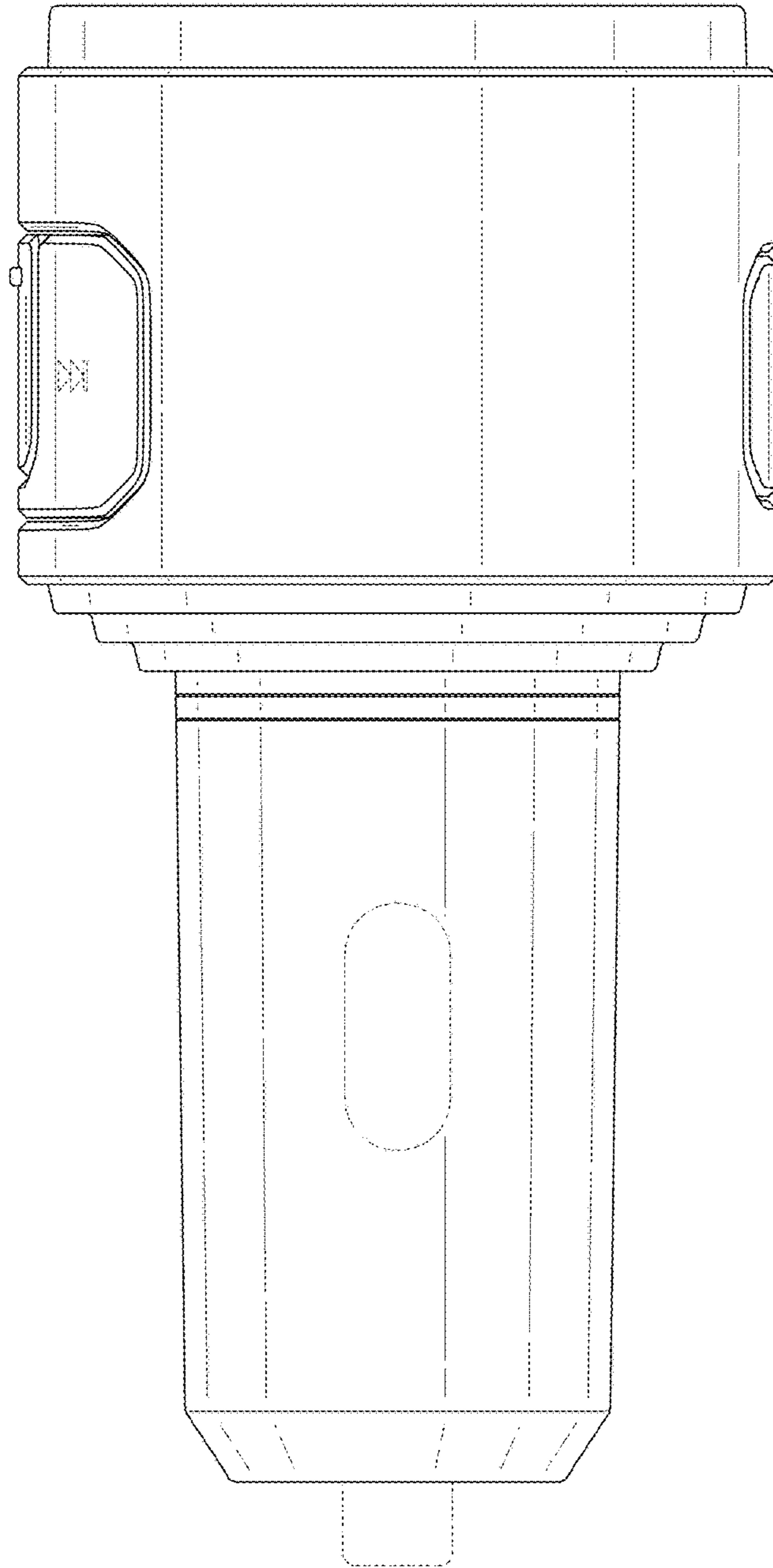

FIG. 6

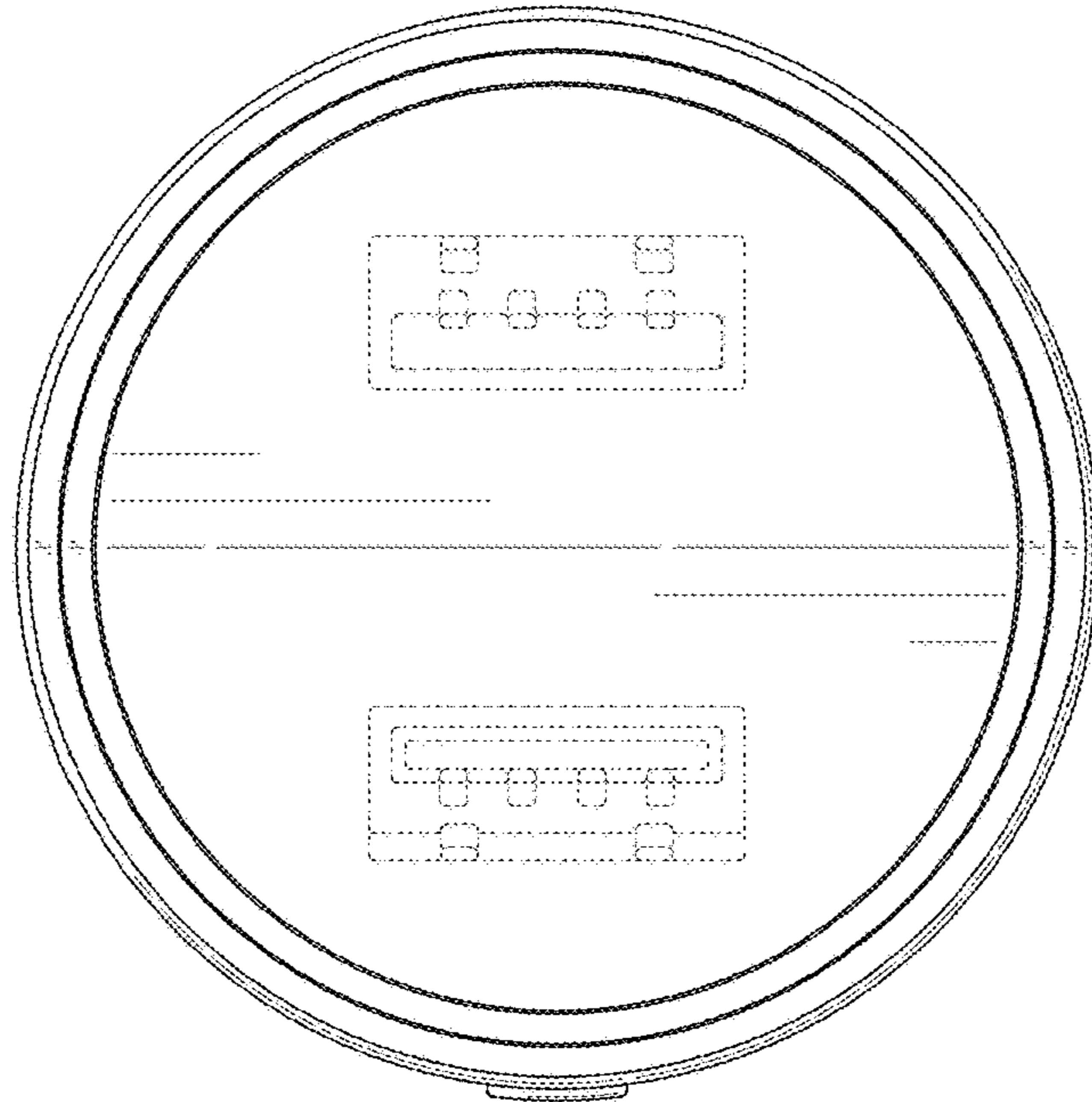

FIG. 7

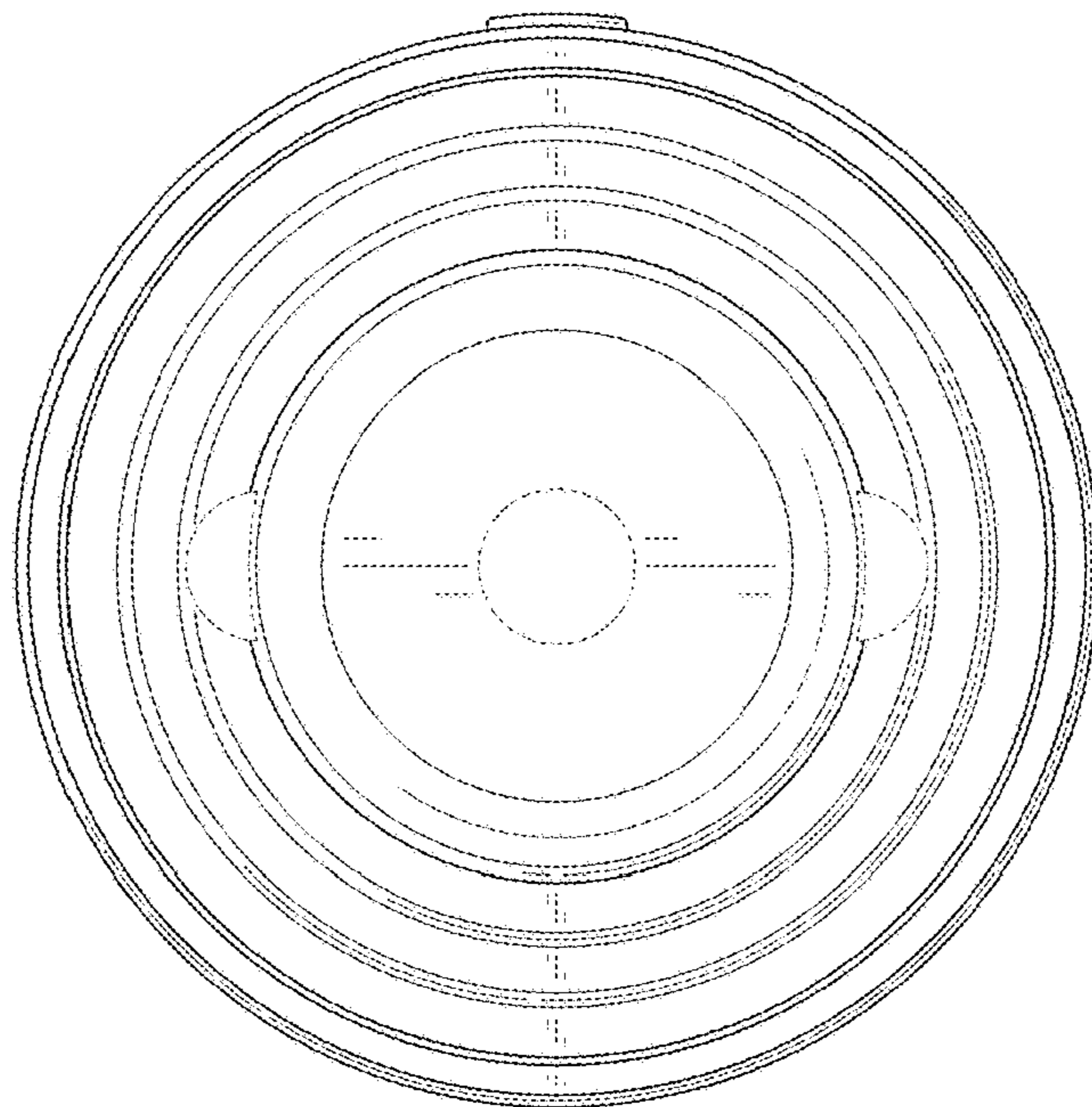

FIG. 8