

US00D860929S

(12) **United States Design Patent**
Kuwano

(10) **Patent No.:** **US D860,929 S**

(45) **Date of Patent:** **** Sep. 24, 2019**

(54) **TIRE**

(71) Applicant: **TOYO TIRE & RUBBER CO., LTD.**,
Itami-shi, Hyogo (JP)

(72) Inventor: **Shingo Kuwano**, Itami (JP)

(73) Assignee: **TOYO TIRE & RUBBER CO., LTD.**,
Itami-shi (JP)

(**) Term: **15 Years**

(21) Appl. No.: **29/637,579**

(22) Filed: **Feb. 20, 2018**

(30) **Foreign Application Priority Data**

Aug. 24, 2017 (JP) 2017-018193

(51) **LOC (12) Cl.** **12-15**

(52) **U.S. Cl.**
USPC **D12/602**

(58) **Field of Classification Search**

USPC D12/579, 596, 597, 602, 603
CPC .. B60C 11/0306; B60C 11/0309; B60C 11/04
See application file for complete search history.

(56) **References Cited**

U.S. PATENT DOCUMENTS

D365,791 S *	1/1996	Brown	D12/514
D444,740 S *	7/2001	Le	D12/602
D497,591 S *	10/2004	Miyazaki	D12/600
D591,227 S *	4/2009	Seibert	D12/602
D608,272 S *	1/2010	Osaka	D12/579
D621,342 S *	8/2010	Osaka	D12/579
D626,913 S *	11/2010	Osaka	D12/600

D630,999 S *	1/2011	Osaka	D12/600
D731,954 S *	6/2015	Pribula	D12/519
D789,289 S *	6/2017	Sareen	D12/596
D811,991 S *	3/2018	Yasunaga	D12/583

FOREIGN PATENT DOCUMENTS

JP 1154385 S 9/2002

* cited by examiner

Primary Examiner — Robert M. Spear

(74) *Attorney, Agent, or Firm* — Sterne, Kessler,
Goldstein & Fox P.L.L.C.

(57) **CLAIM**

The ornamental design for a tire, as shown and described.

DESCRIPTION

FIG. 1 is a front perspective view of a tire showing the claimed design;

FIG. 2 is a front view thereof, the rear view being the same; FIG. 3 is a top plan view thereof, the bottom plan view being the same;

FIG. 4 is a right side view thereof, the left side view being the same;

FIG. 5 is an enlarged view taken along line 5-5 in FIG. 1; FIG. 6 is an enlarged view of the portion 6-6 in FIG. 2; and, FIG. 7 is a cross-sectional view taken along line 7-7 in FIG. 6.

In the drawings, the broken lines show portions of the tire that form no part of the claimed design.

1 Claim, 7 Drawing Sheets

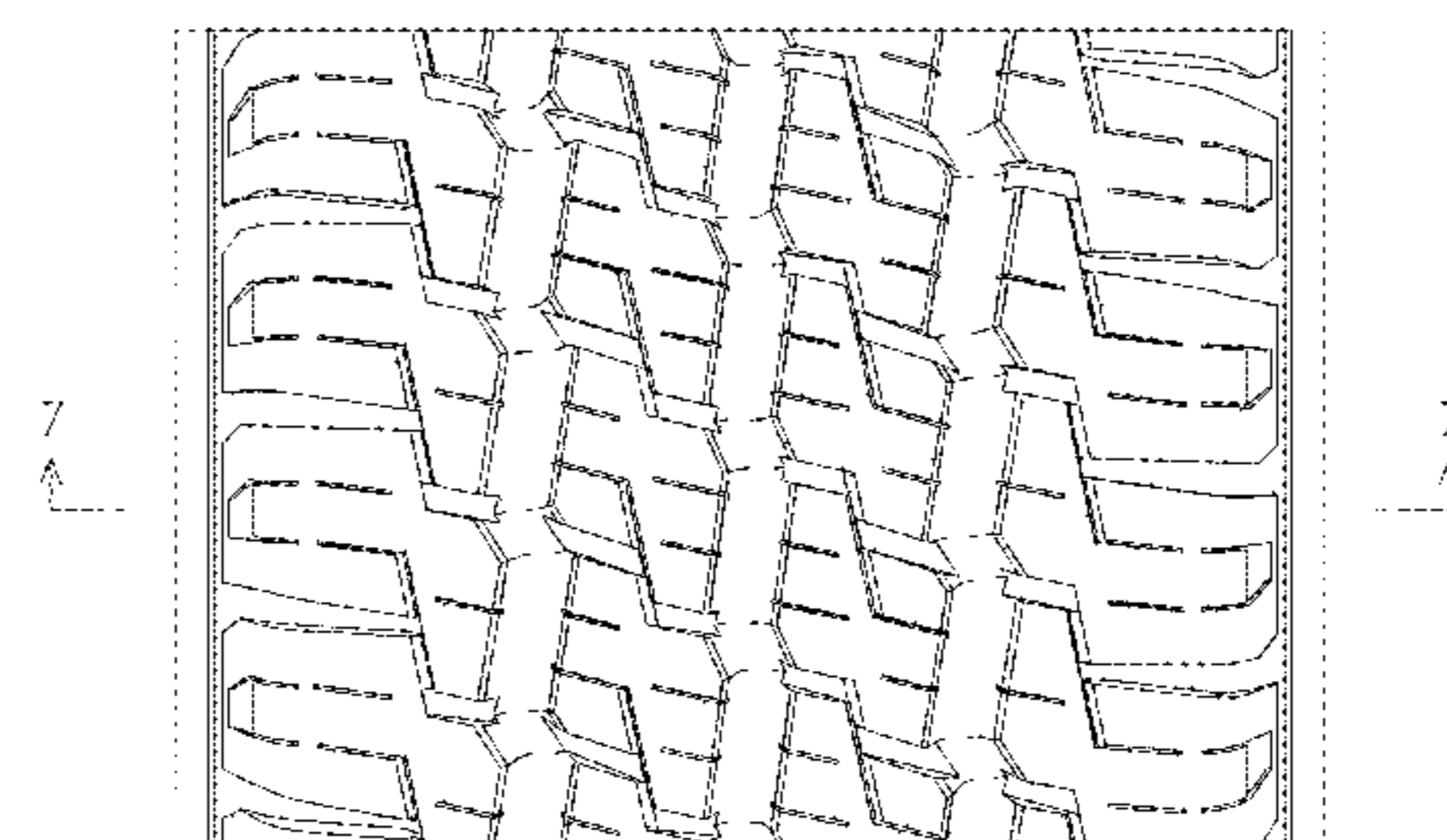
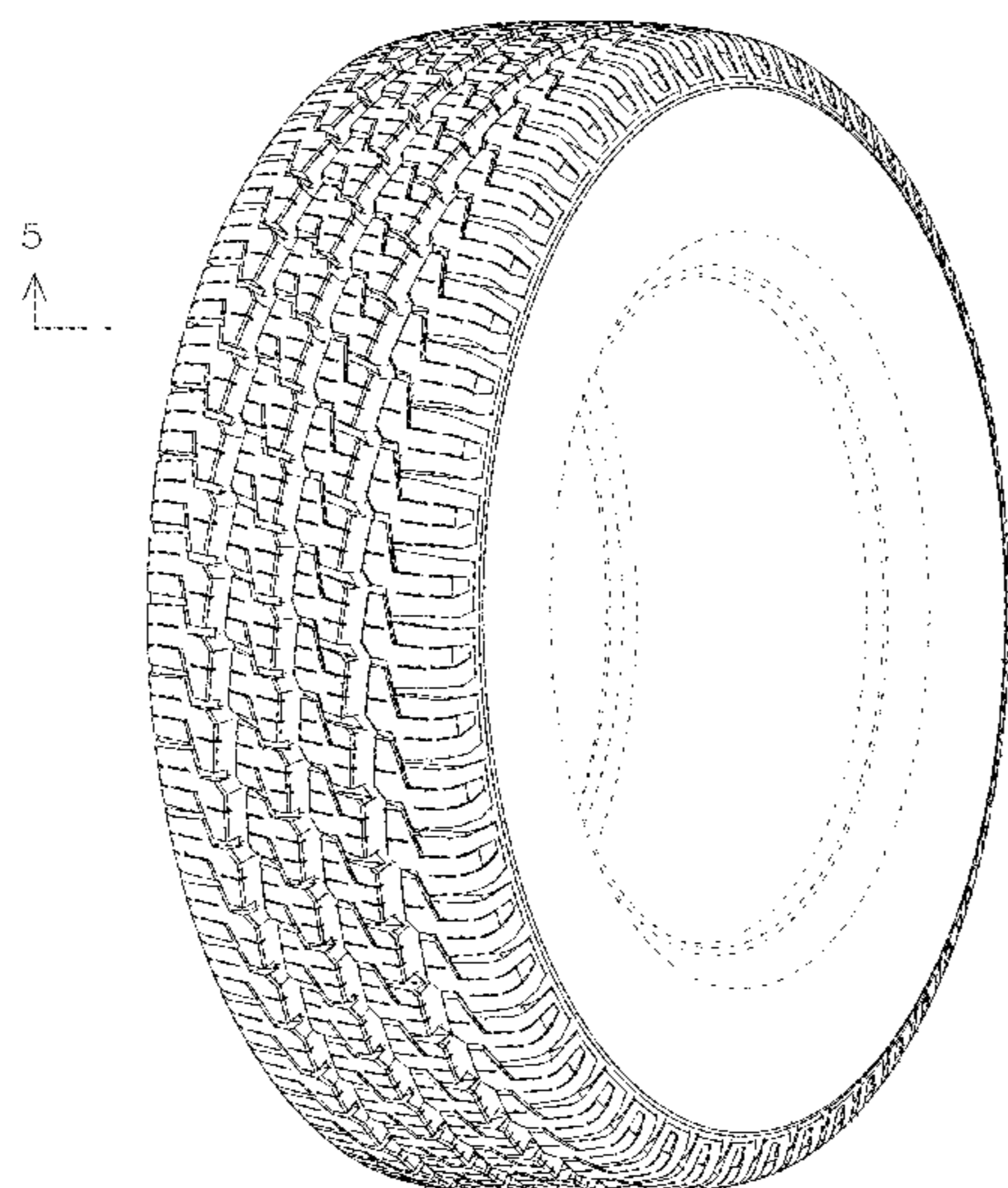

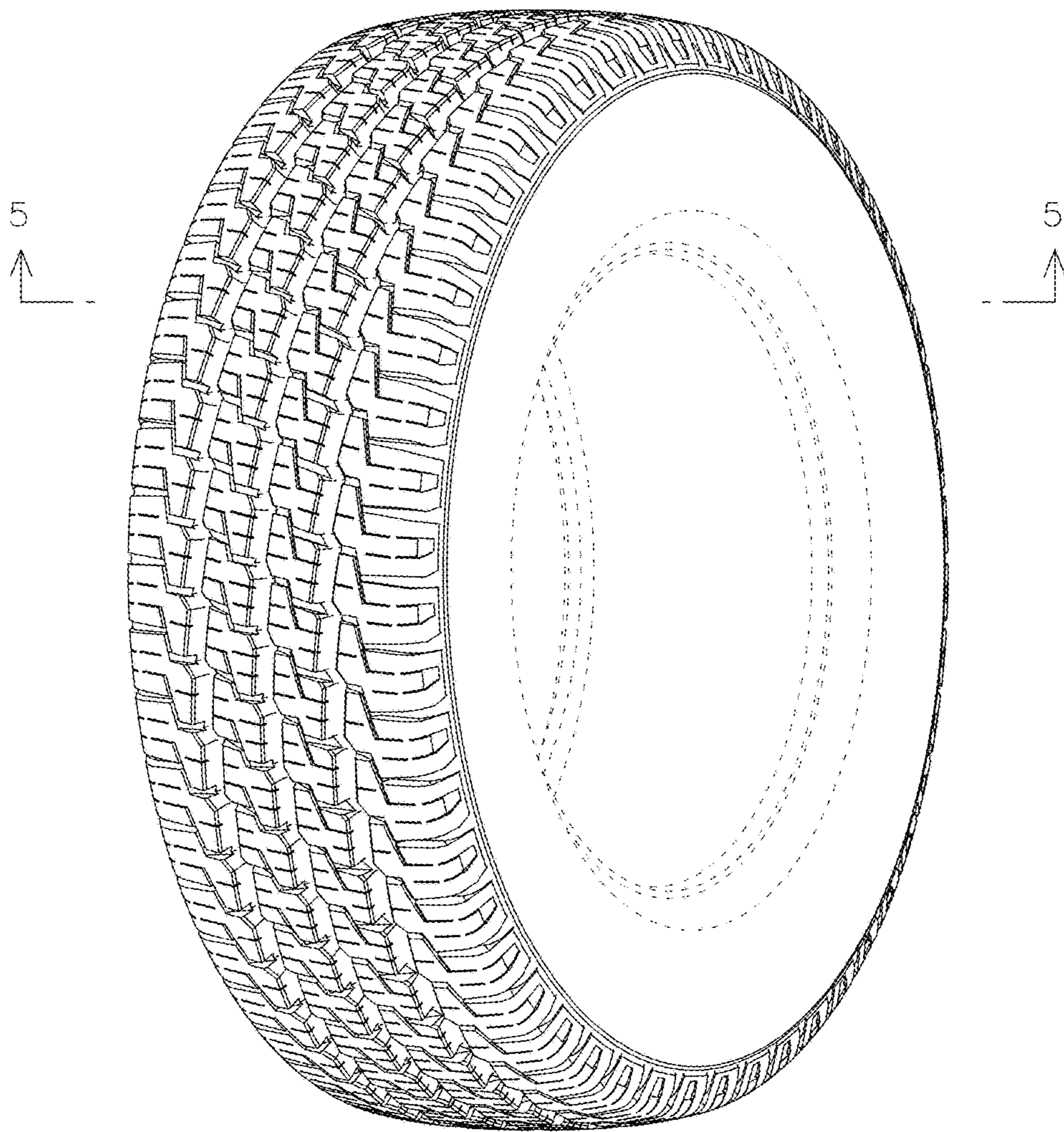

FIG. 1

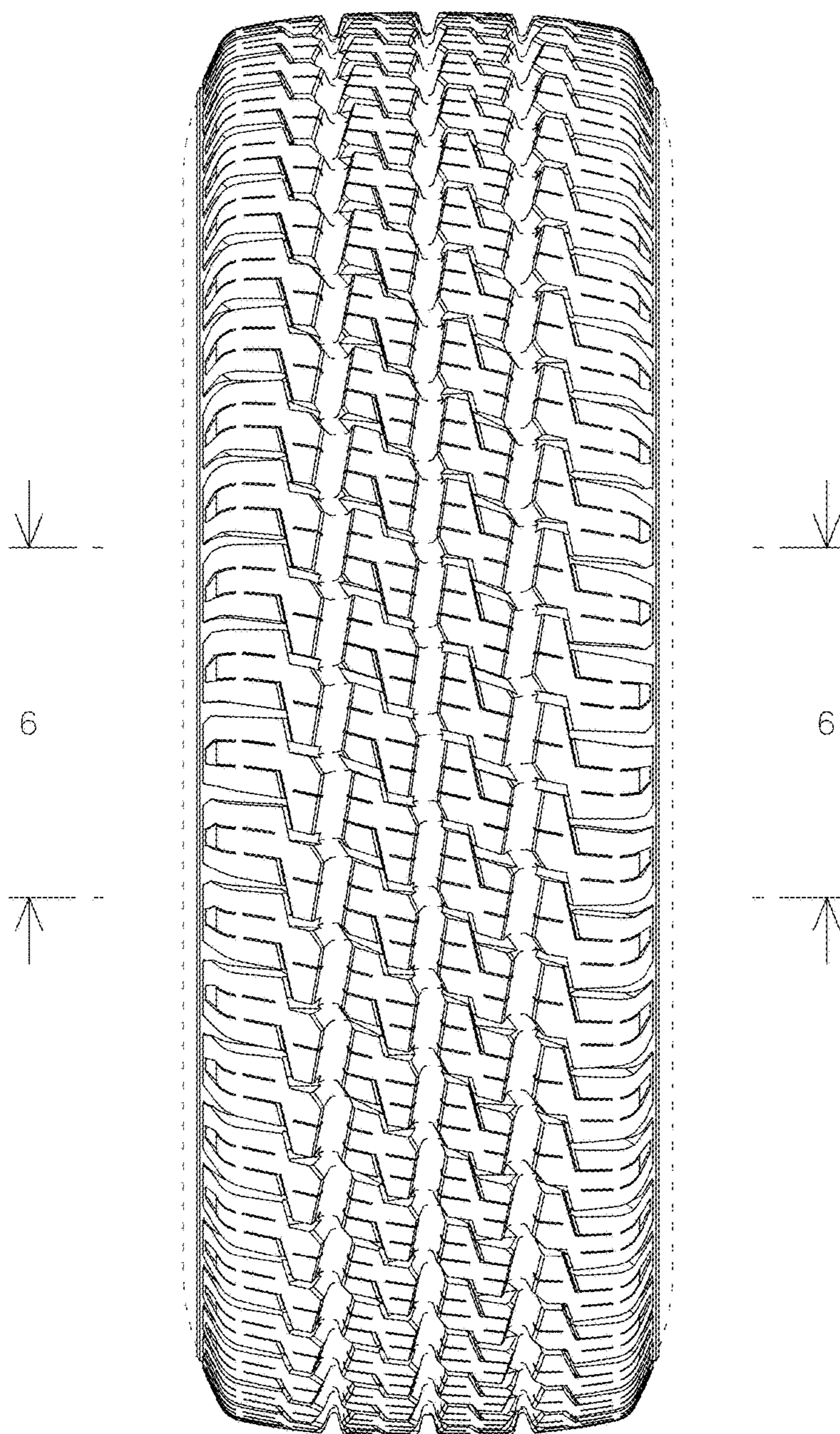

FIG. 2

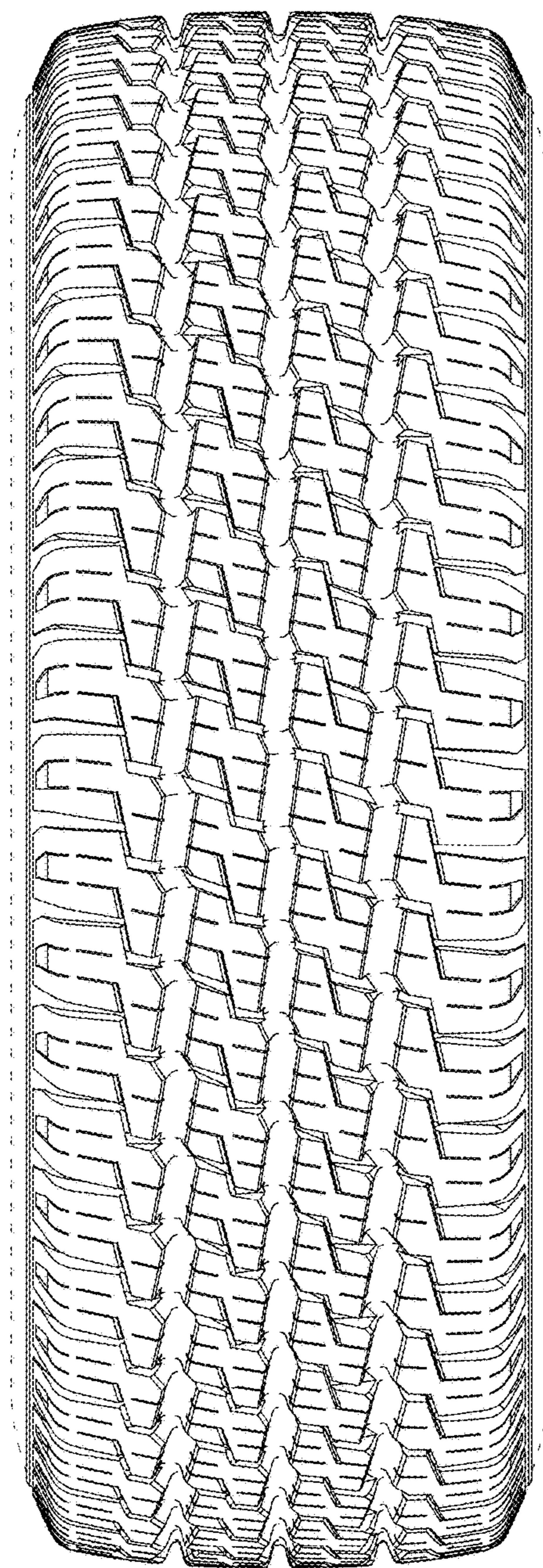

FIG. 3

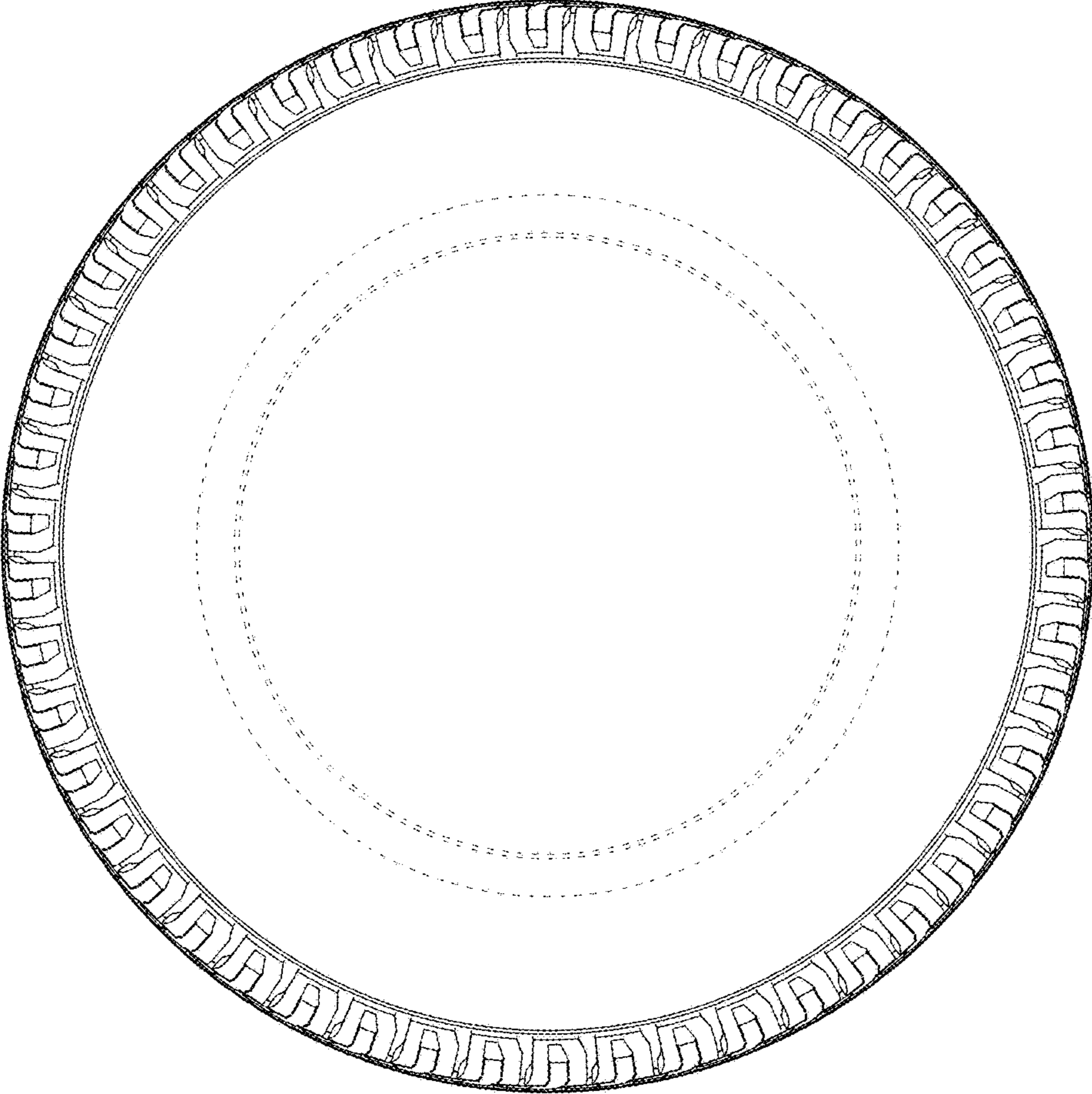

FIG. 4

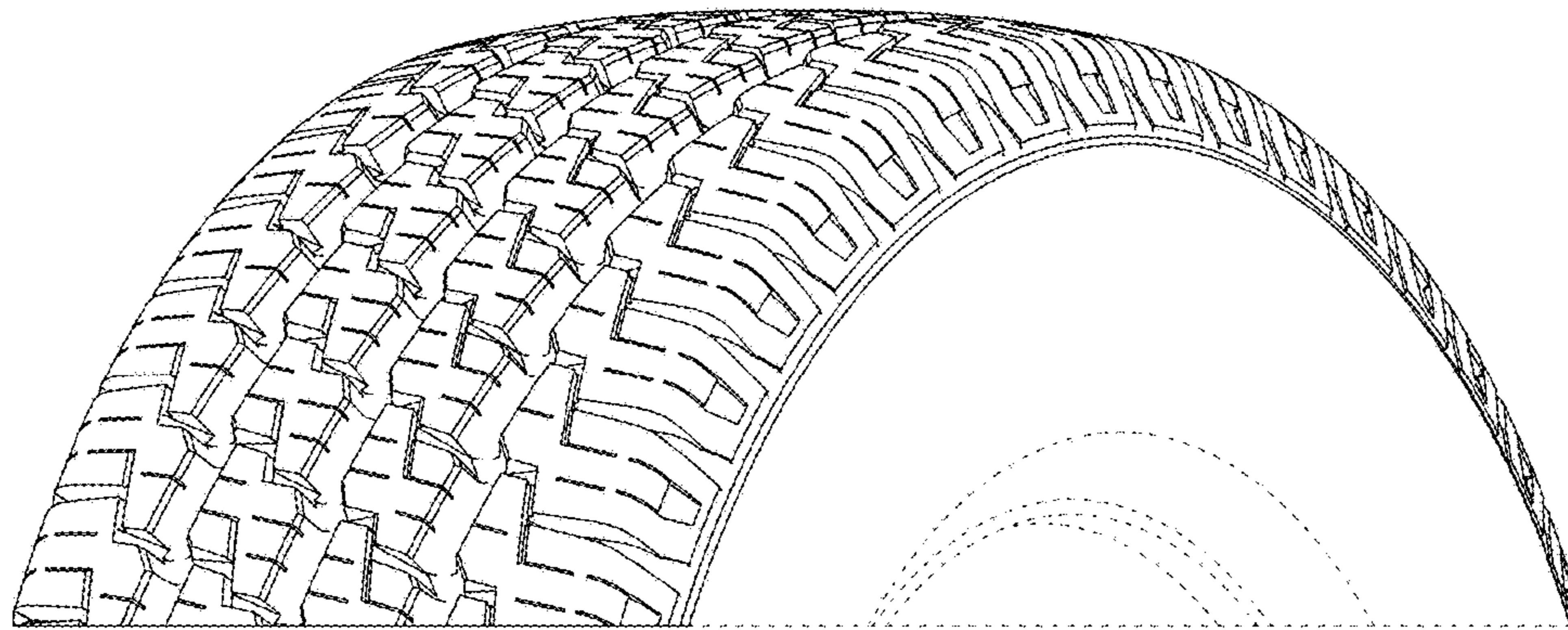

FIG. 5

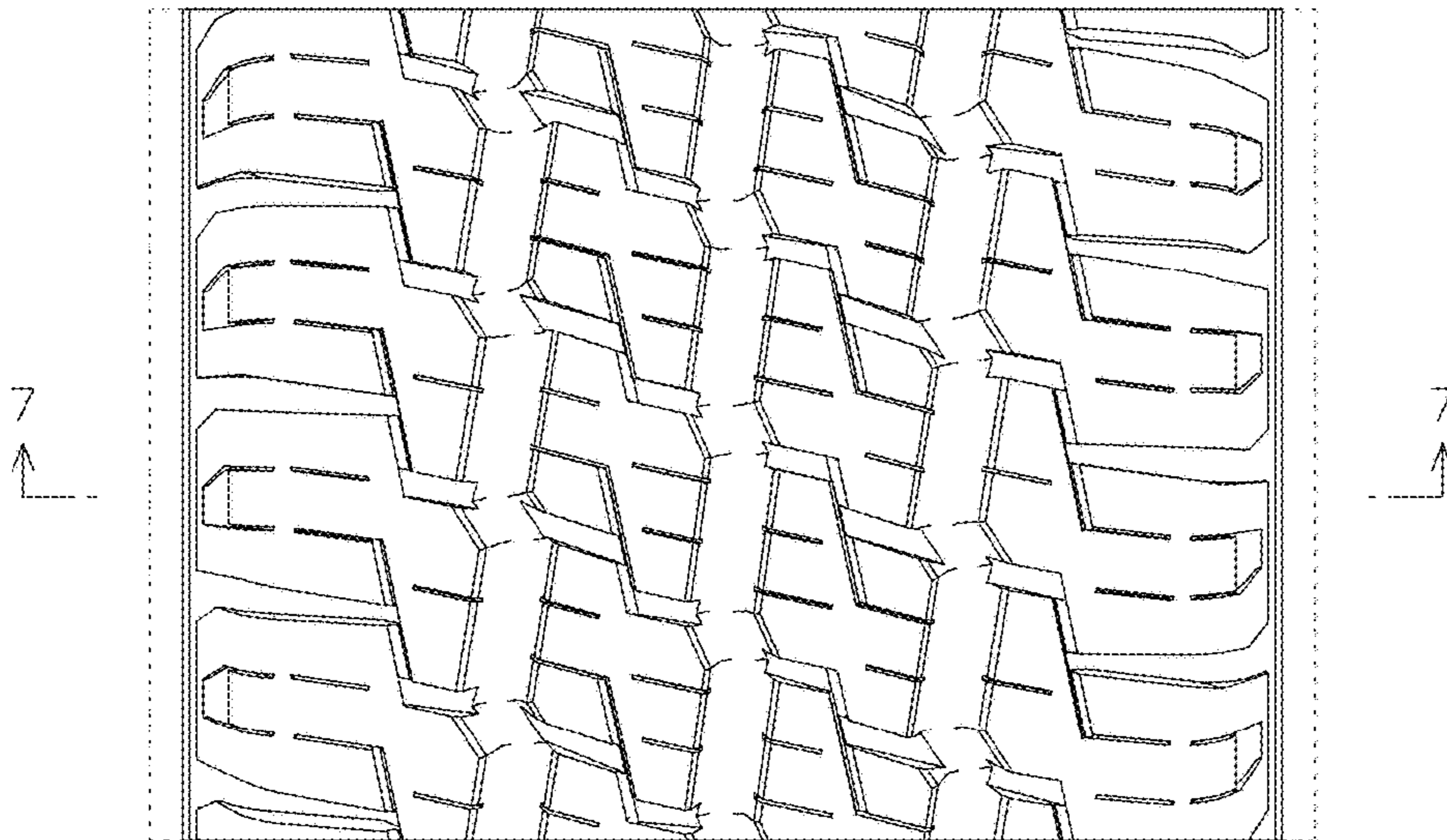

FIG. 6

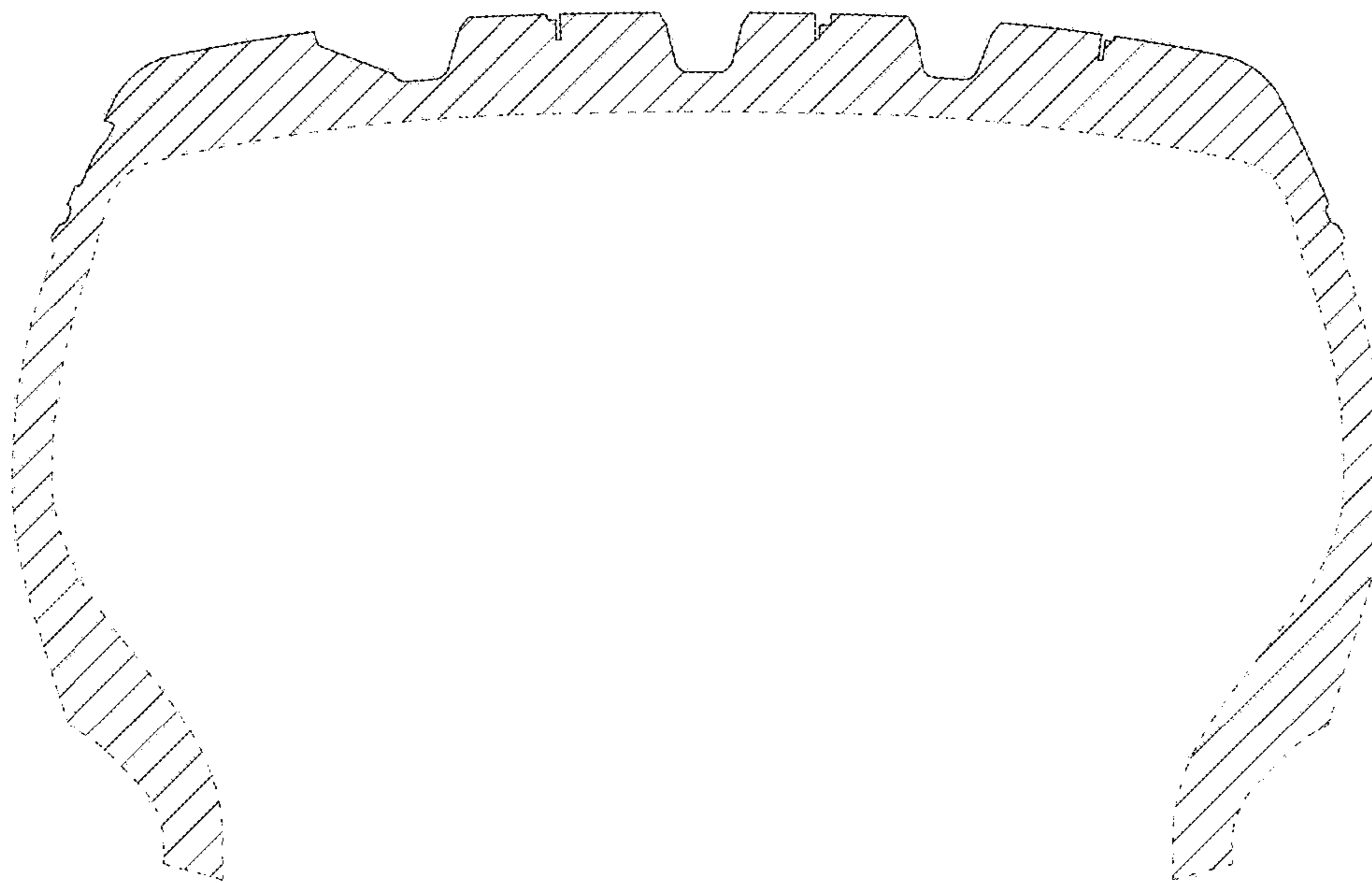

FIG. 7