

US00D860917S

(12) **United States Design Patent**
Tan et al.

(10) **Patent No.:** **US D860,917 S**

(45) **Date of Patent:** **** Sep. 24, 2019**

(54) **SCOOTER**

(71) Applicant: **Shenzhen Leqi Intelligent Technology Co., Ltd.**, Shenzhen (CN)

(72) Inventors: **Di Tan**, Shenzhen (CN); **FanFan Jiang**, Shenzhen (CN)

(73) Assignee: **SHENZHEN LEQI INTELLIGENT TECHNOLOGY CO., LTD.**, Shenzhen (CN)

(**) Term: **15 Years**

(21) Appl. No.: **29/643,943**

(22) Filed: **Apr. 13, 2018**

(51) **LOC (12) Cl.** **21-01**

(52) **U.S. Cl.**
USPC **D12/423**

(58) **Field of Classification Search**
USPC D21/419, 421, 423, 760, 765, 771;
D12/1, 8, 107, 110, 112, 113, 114
CPC B62K 3/002; B62K 9/00; B62K 2202/00;
B60Y 2200/126
See application file for complete search history.

(56) **References Cited**

U.S. PATENT DOCUMENTS

7,584,974	B2 *	9/2009	Jackman	B62K 3/002
					180/181
7,976,035	B2 *	7/2011	Chan	B62K 15/00
					280/87.05
8,511,695	B2 *	8/2013	Johnson	B62K 3/002
					280/87.041
D806,176	S *	12/2017	Peng	D21/423
D815,215	S *	4/2018	Desberg	D21/423
D827,036	S *	8/2018	Sebban	D21/423

D829,826	S *	10/2018	Liu	D21/423
D830,468	S *	10/2018	Liu	D21/423
D834,097	S *	11/2018	Lin	D21/423
D837,303	S *	1/2019	Desberg	D21/423

* cited by examiner

Primary Examiner — Cynthia M. Chin

(57) **CLAIM**

The ornamental design for a scooter, as shown and described.

DESCRIPTION

FIG. 1 is a perspective view of the scooter showing my new design;

FIG. 2 is a bottom perspective view thereof;

FIG. 3 is a left side elevational view thereof;

FIG. 4 is a right side elevational view thereof;

FIG. 5 is front elevational view thereof;

FIG. 6 is a rear elevational view thereof;

FIG. 7 is a top plan view thereof;

FIG. 8 is a bottom plan view thereof;

FIG. 9 is an enlarged partial view of handlebars taken from the top of FIG. 1;

FIG. 10 is an enlarged partial view of the scooter taken from the left side of FIG. 1;

FIG. 11 is an enlarged partial view the handlebars taken from the bottom right of FIG. 1;

FIG. 12 is an enlarged partial view of the scooter taken from the top left of FIG. 2.

FIG. 13 is an enlarged partial view of the scooter taken from the left side of FIG. 2; and,

FIG. 14 is an enlarged partial view of the handlebars of scooter taken from the bottom of FIG. 2.

The dash-dot broken lines represent the boundaries of the enlarged partial views of FIGS. 9-14 and form no part of the claimed design.

1 Claim, 14 Drawing Sheets

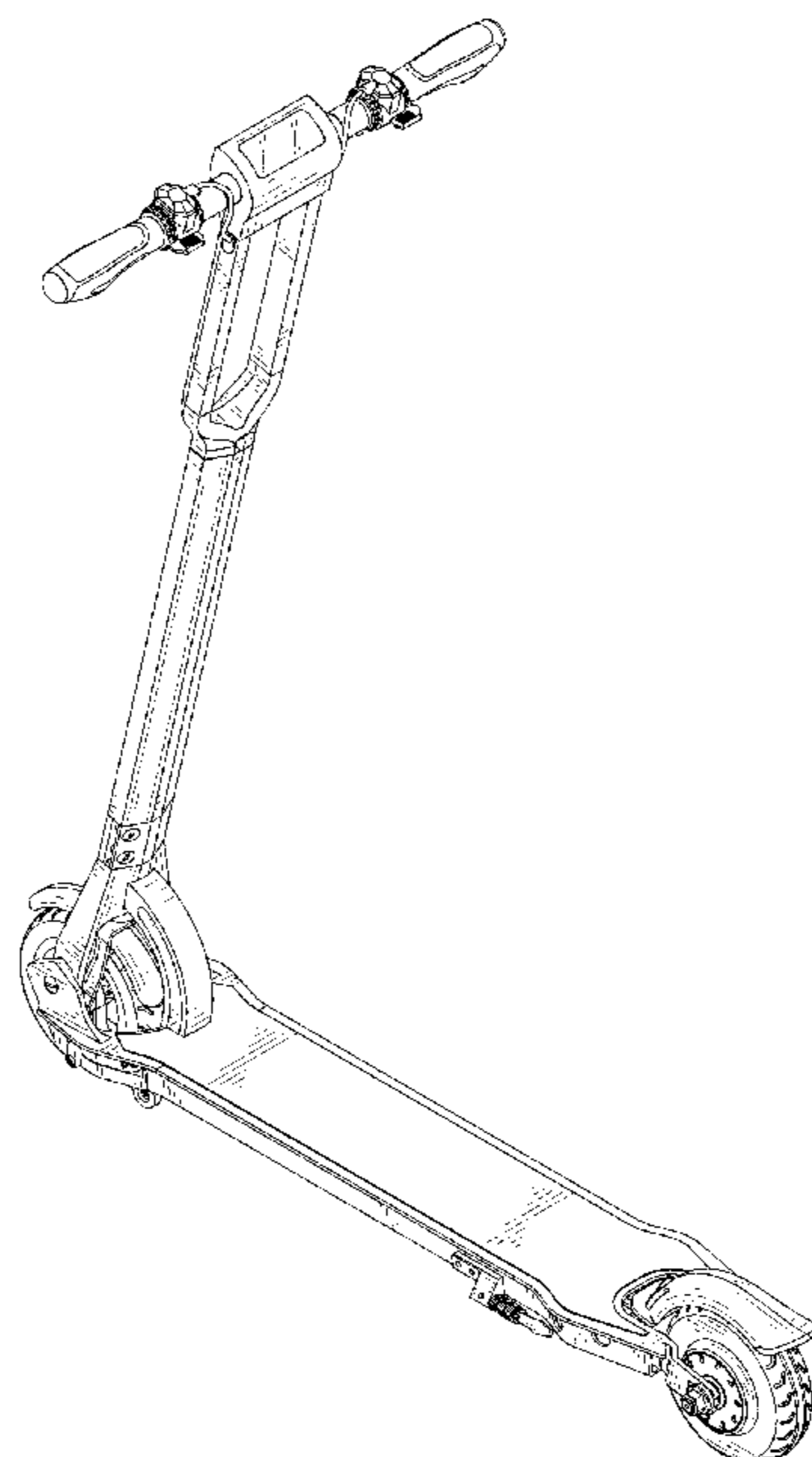

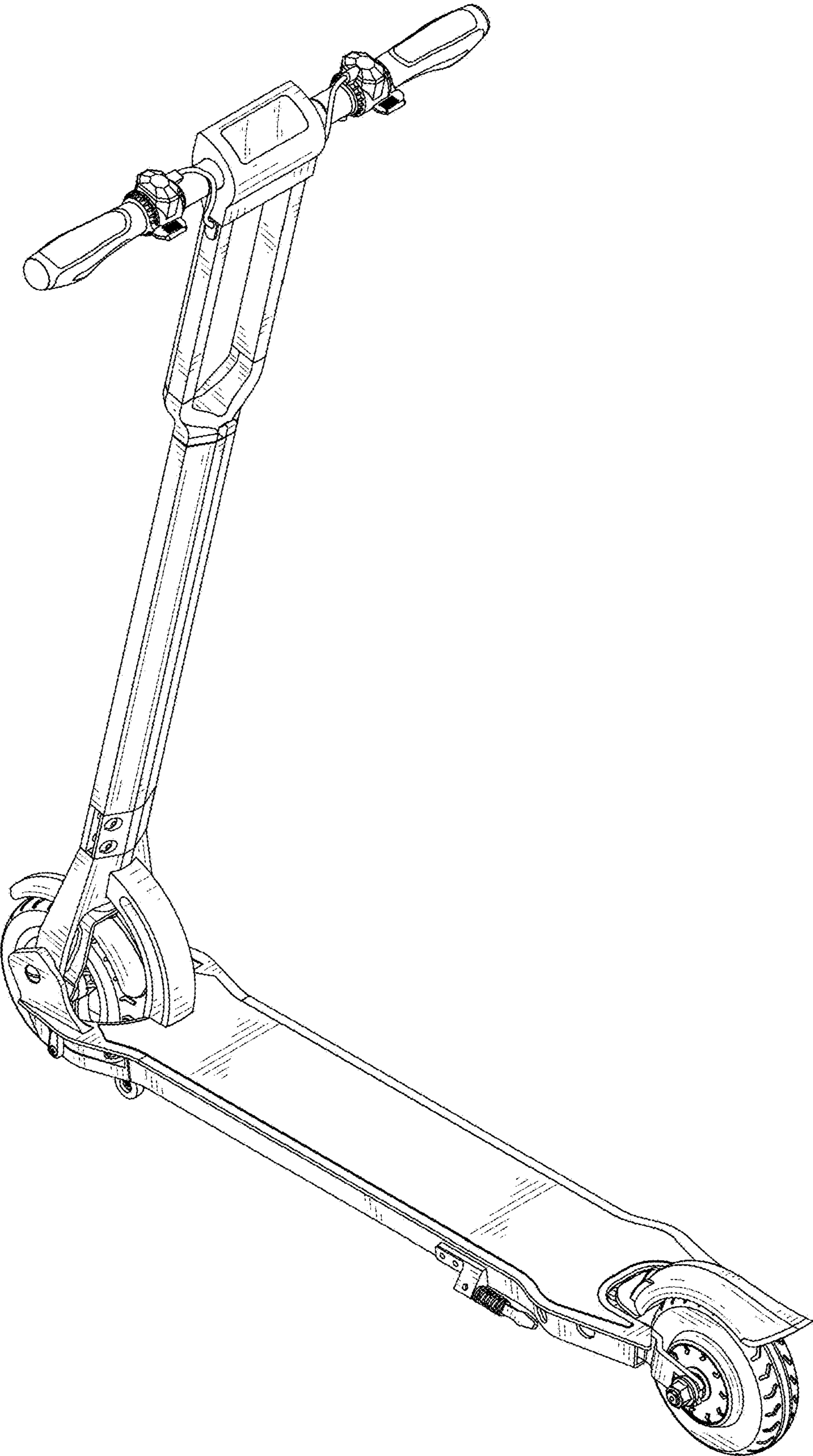

FIG. 1

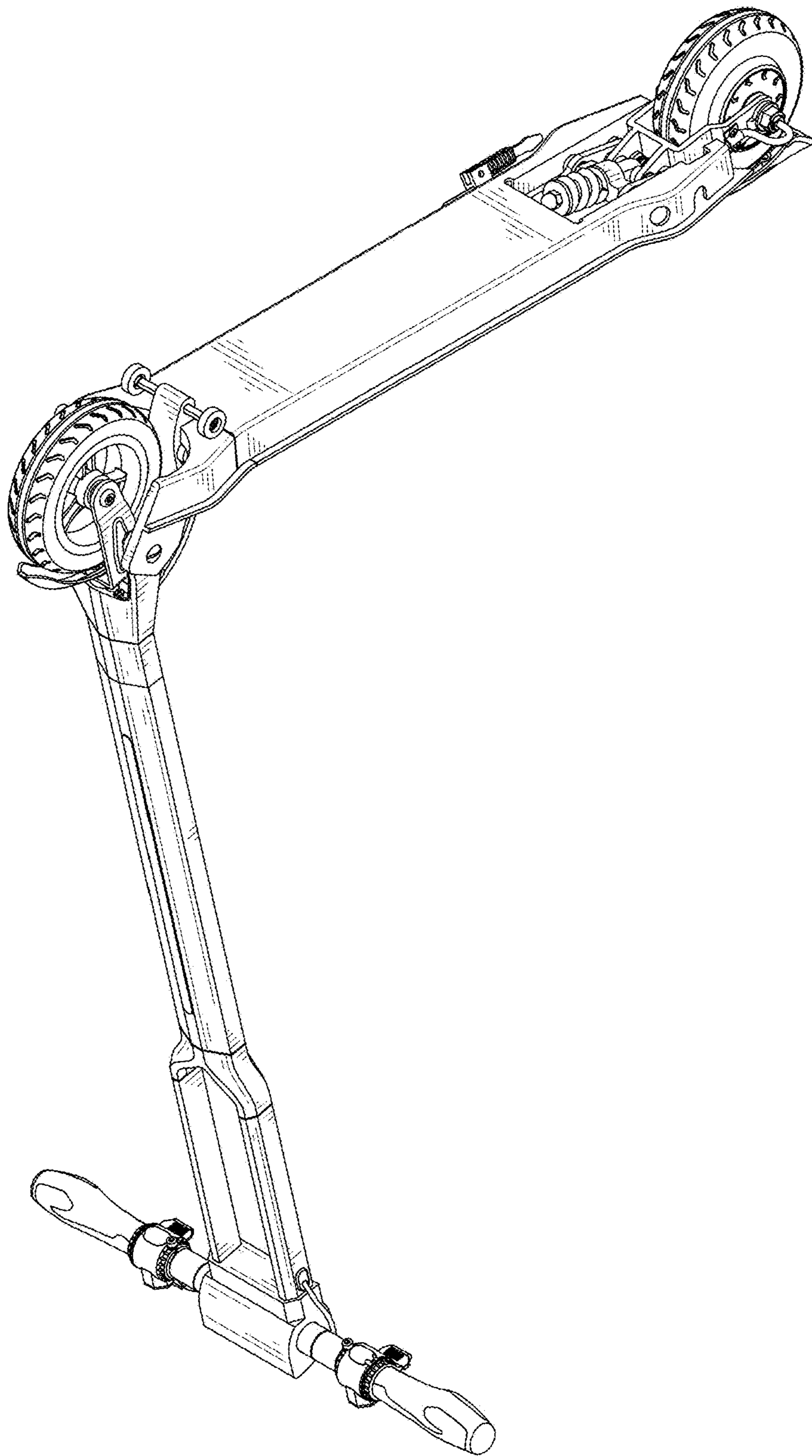

FIG. 2

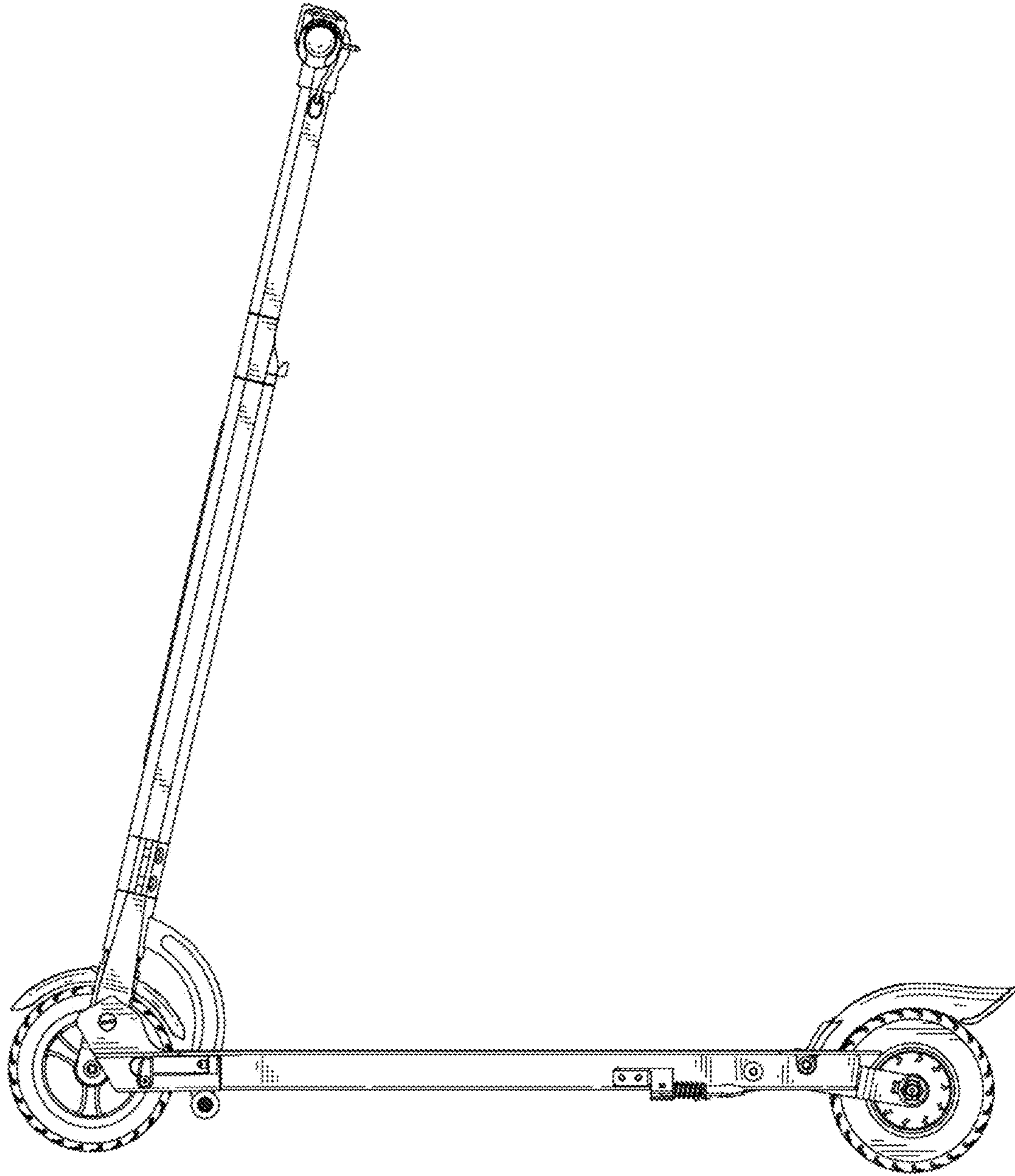

FIG. 3

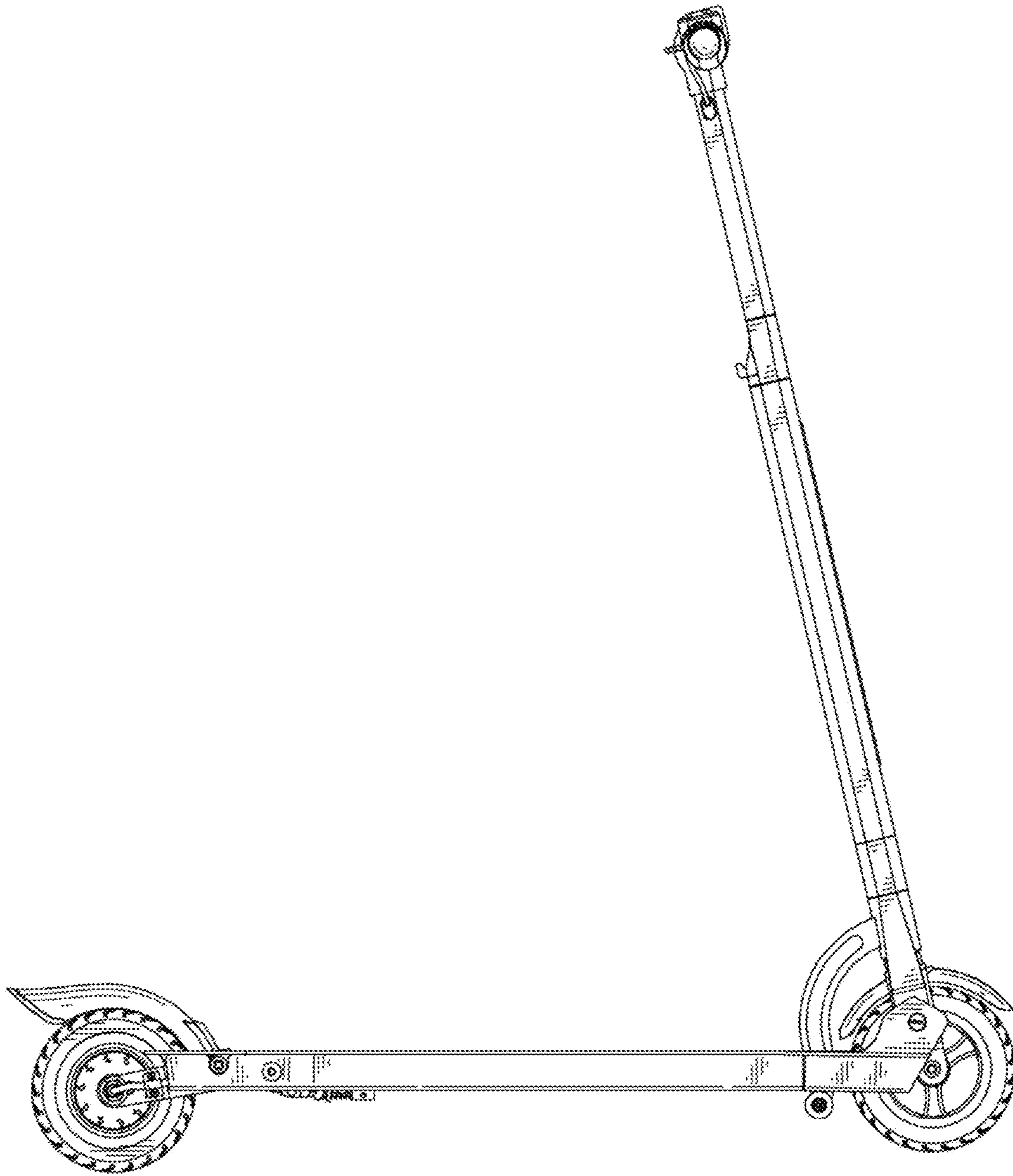

FIG. 4

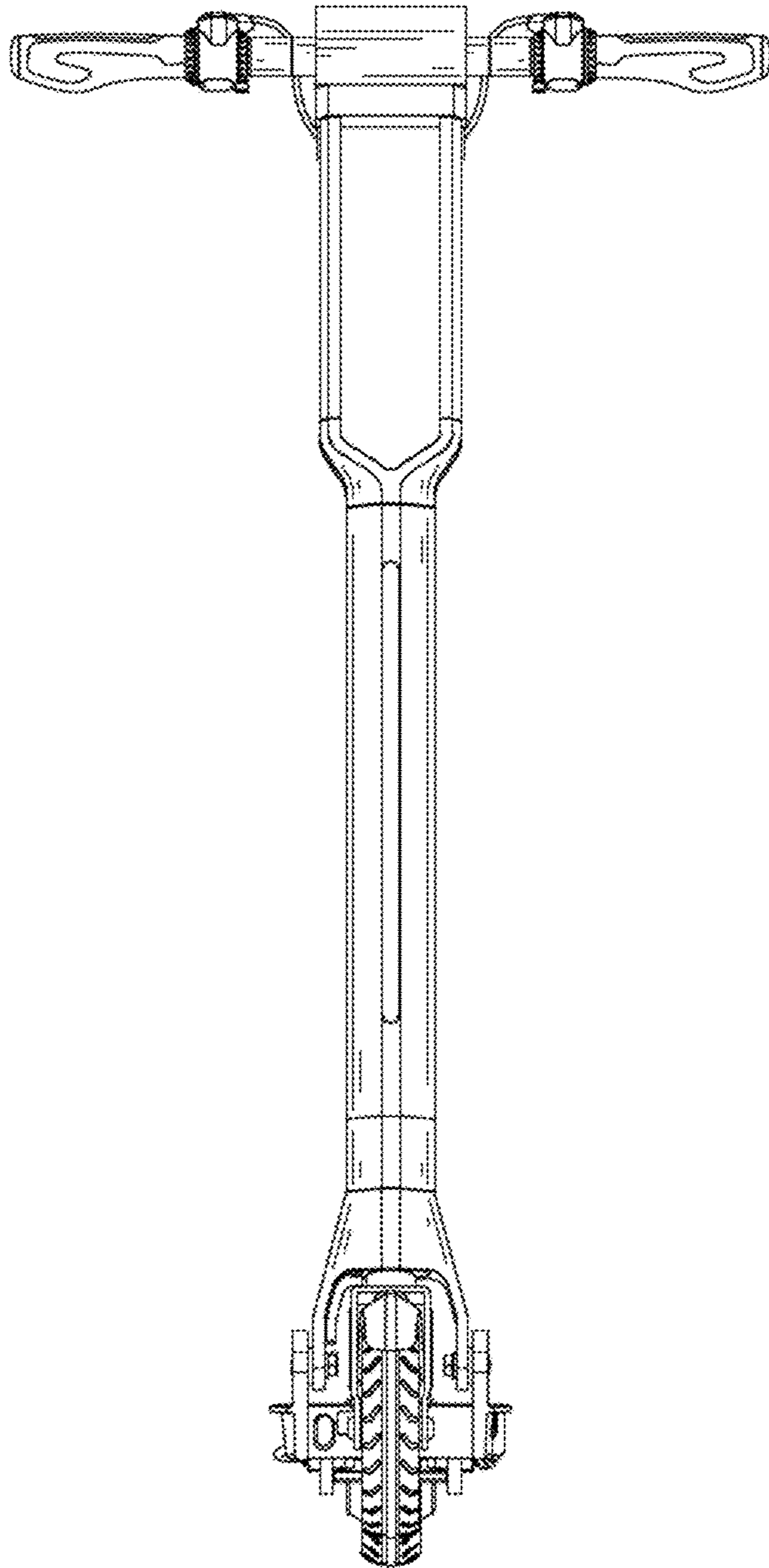

FIG. 5

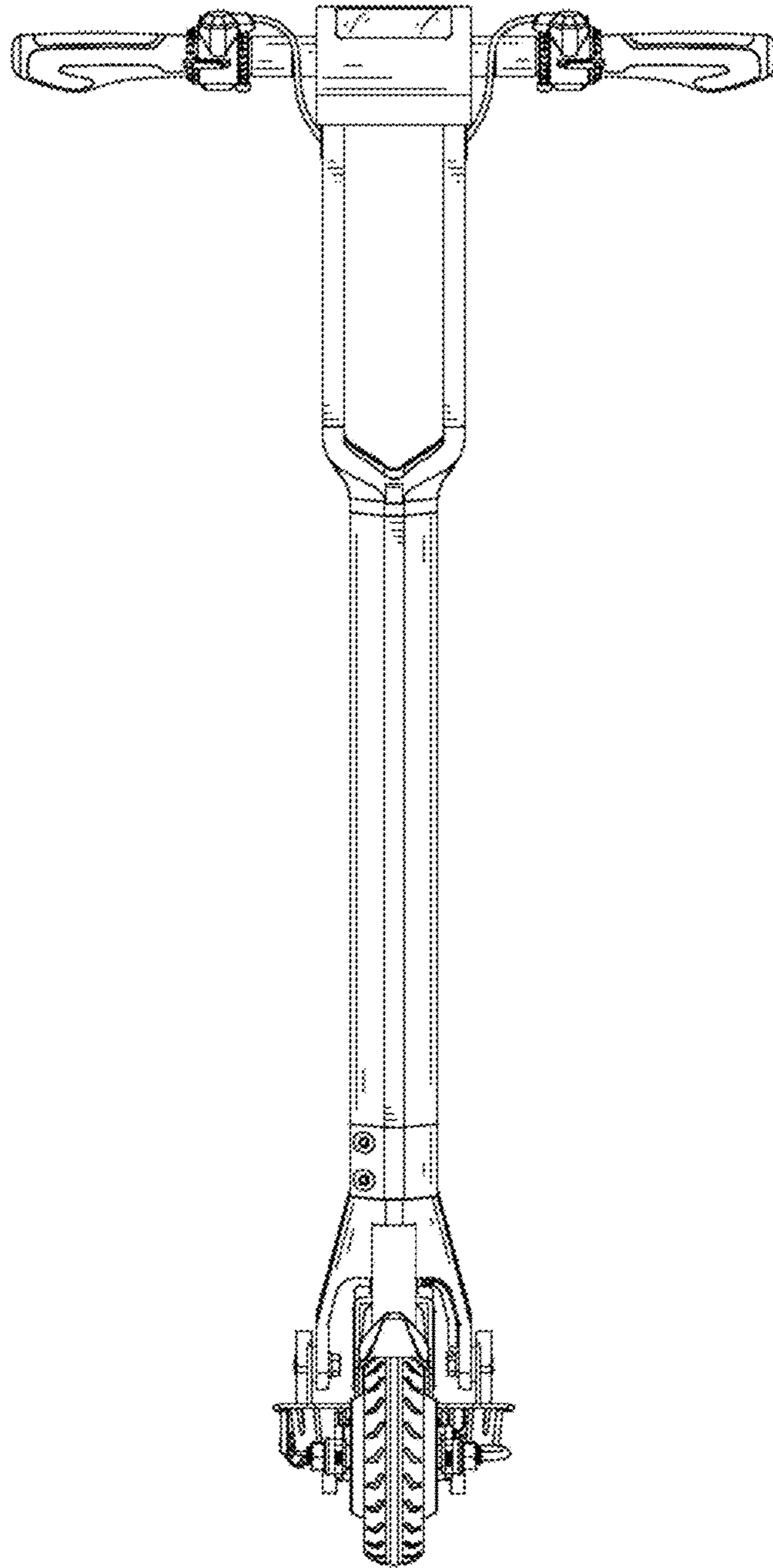

FIG. 6

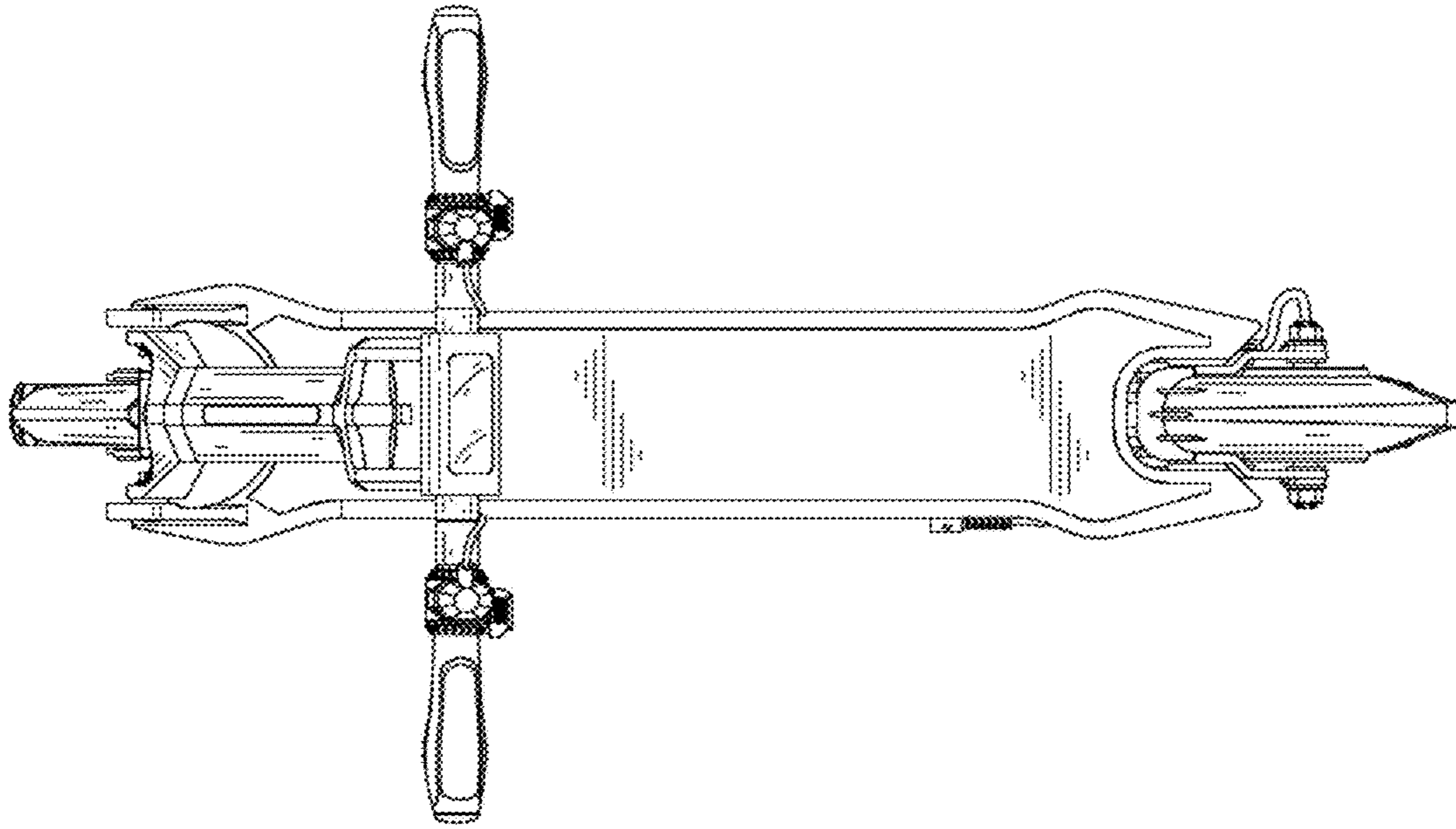

FIG. 7

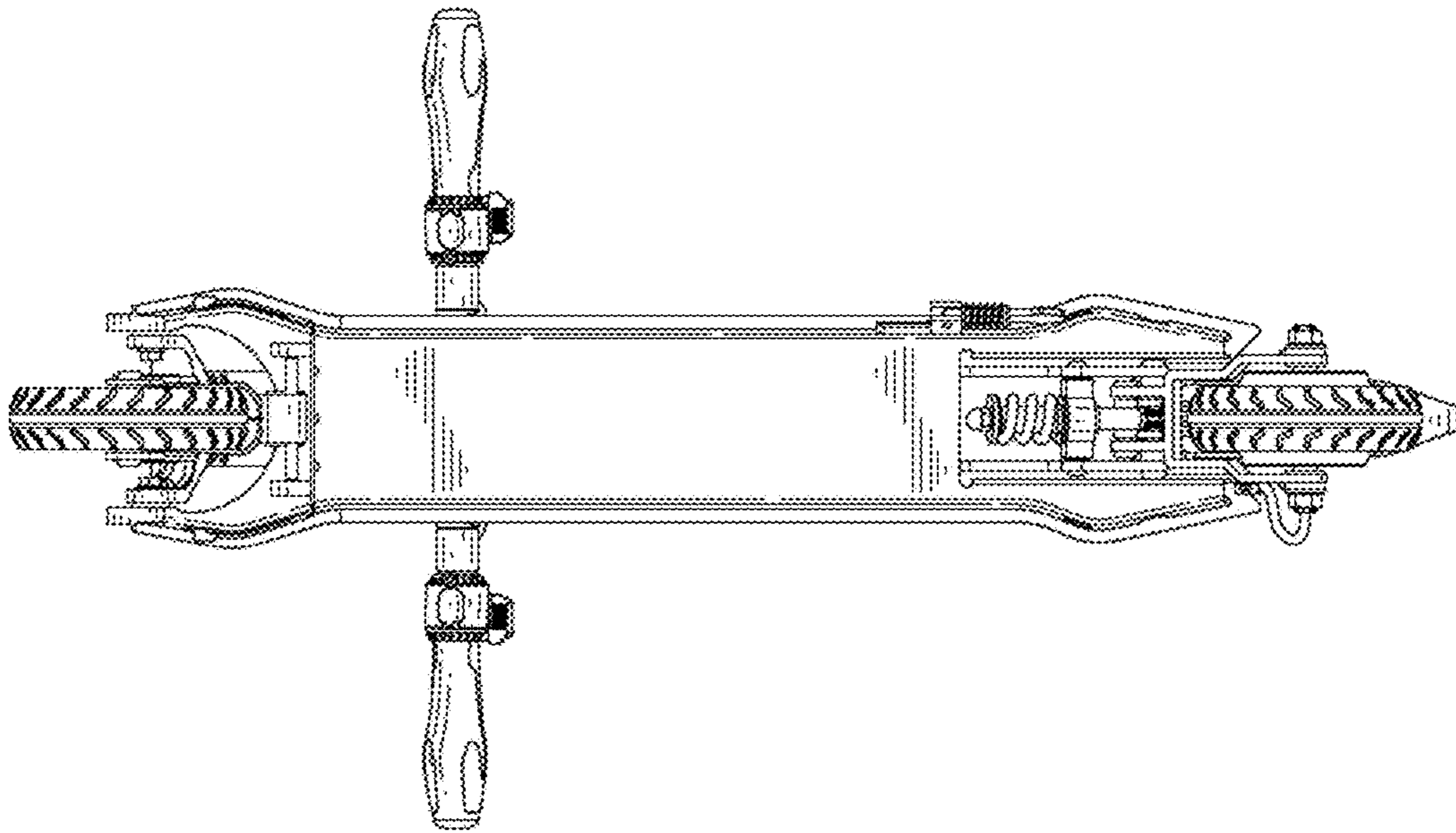

FIG. 8

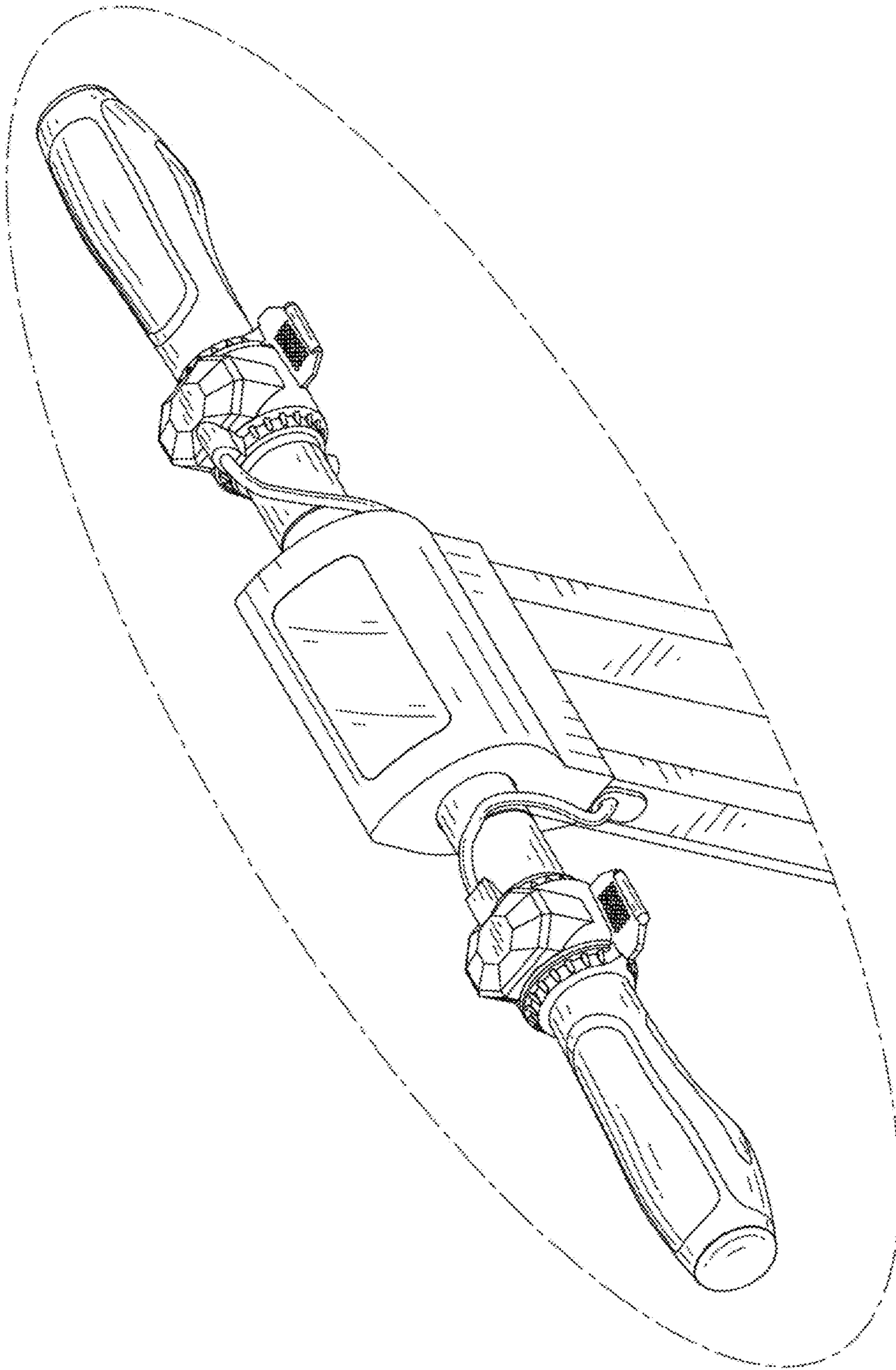

FIG. 9

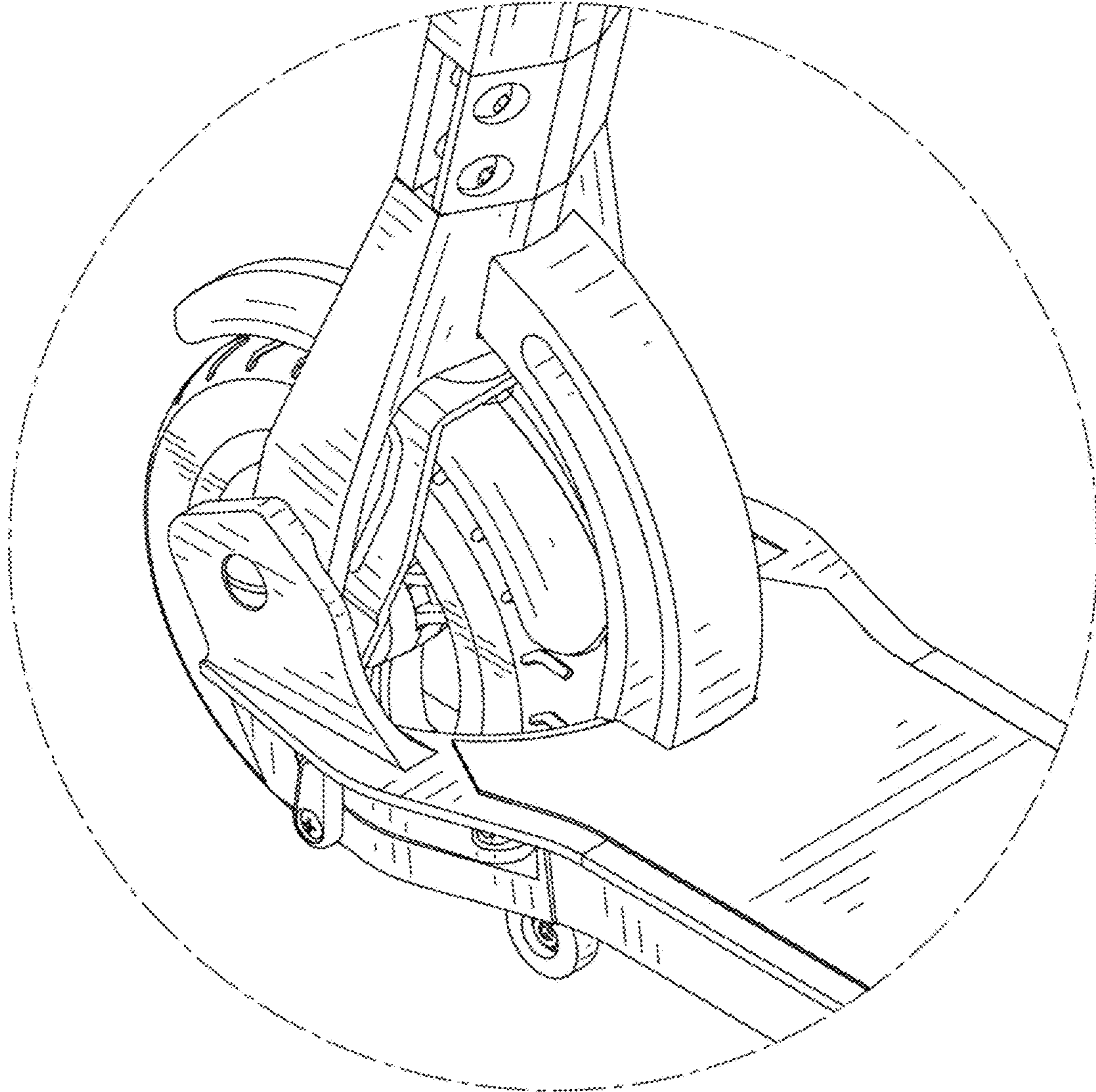

FIG. 10

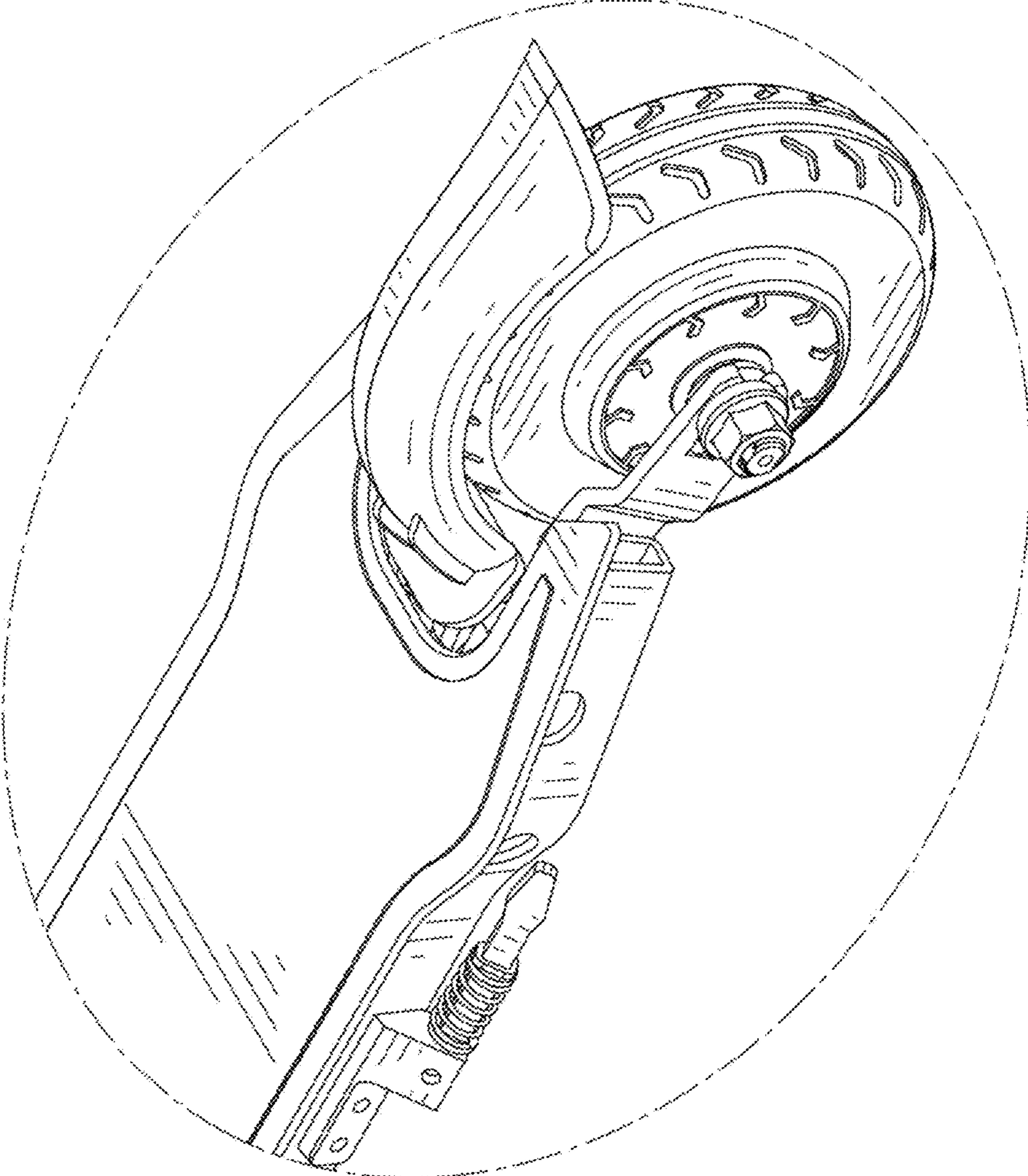

FIG. 11

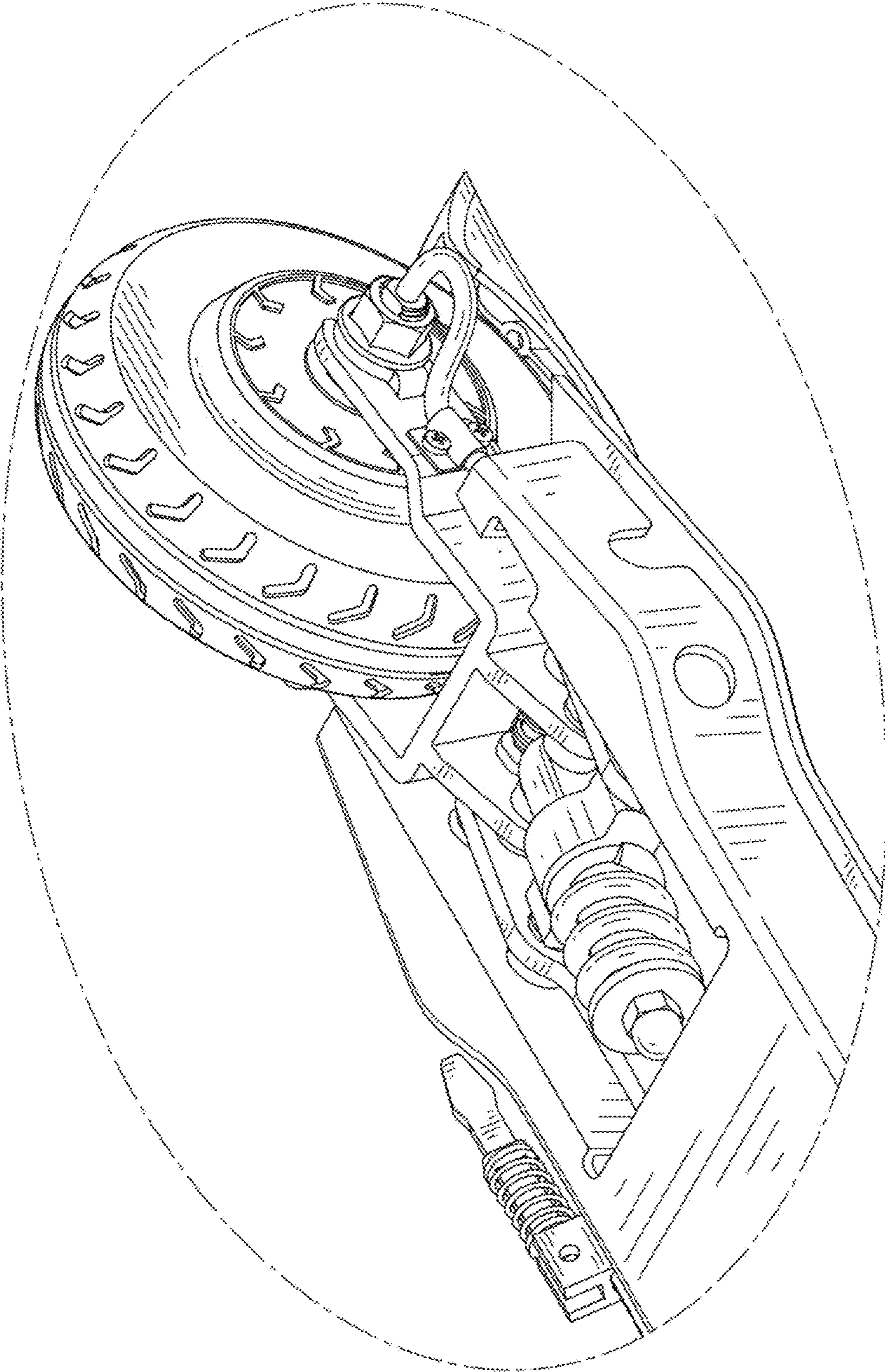

FIG. 12

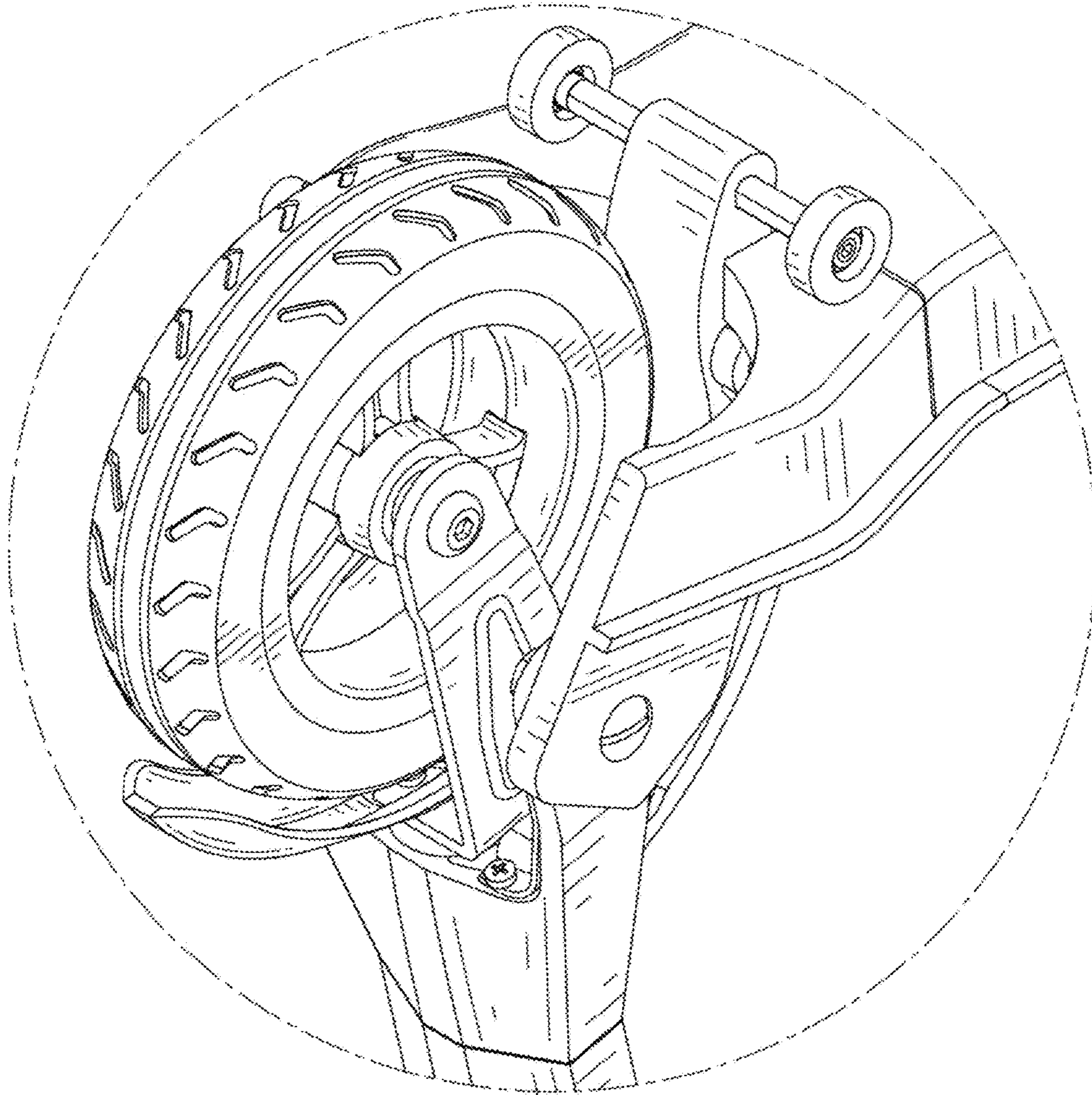

FIG. 13

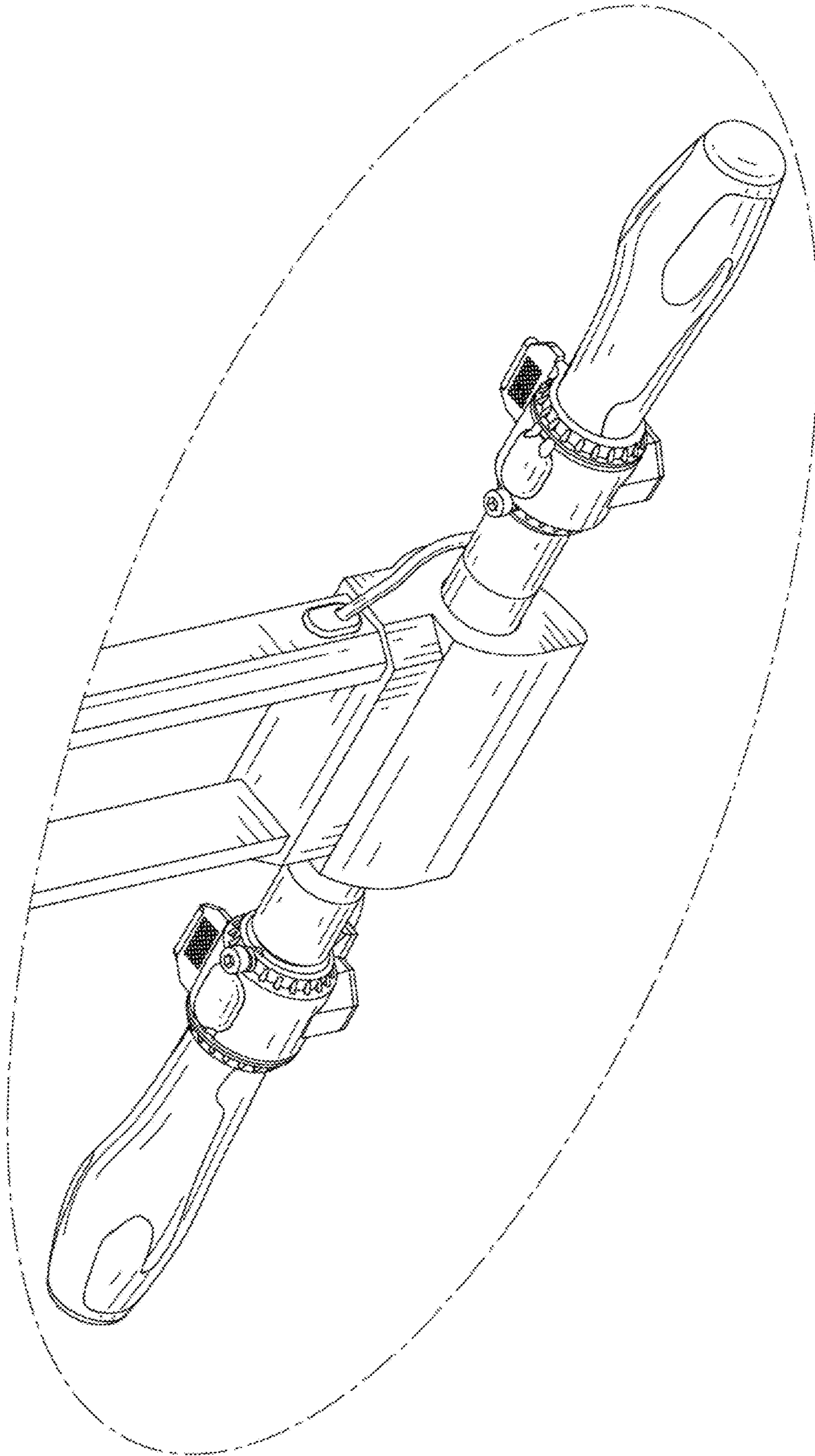

FIG. 14