

US00D860698S

(12) **United States Design Patent**
Godwin

(10) **Patent No.:** **US D860,698 S**

(45) **Date of Patent:** **** Sep. 24, 2019**

(54) **TABLE**

(71) Applicant: **Alumni Classroom Furniture Inc.,**
Waterloo (CA)

(72) Inventor: **Paul Godwin, Waterloo (CA)**

(73) Assignee: **Alumni Classroom Furniture Inc.,**
Waterloo (CA)

(**) Term: **15 Years**

(21) Appl. No.: **29/590,738**

(22) Filed: **Jan. 12, 2017**

(51) **LOC (12) Cl.** **06-06**

(52) **U.S. Cl.**

USPC **D6/707.22**

(58) **Field of Classification Search**

USPC D6/338, 641, 656, 656.1, 656.13, 656.15,
D6/656.18, 685, 686, 687, 691.1, 691.6,
D6/692.1, 693, 696, 696.1, 696.3, 696.4,
D6/697, 697.1, 697.2, 704, 705.1, 707,
D6/707.21, 707.22, 707.23, 708.24

CPC A47B 3/00; A47B 7/00; A47B 7/02; A47B
13/00; A47B 13/08; A47B 21/00; A47B
21/02; A47B 41/00; A47B 41/02; A47B
2200/0001; A47B 2200/0003; A47B
2200/0035

See application file for complete search history.

(56) **References Cited**

U.S. PATENT DOCUMENTS

D190,998 S * 8/1961 Schultz D6/688
3,342,147 A * 9/1967 Shettles A47B 87/002
108/185
3,683,825 A * 8/1972 Sheldon A47B 3/00
108/176
D227,966 S * 7/1973 Duern D6/696
D237,336 S * 10/1975 Loscalzo D6/693.3
D300,396 S * 3/1989 Kelley D6/693.3

D328,209 S * 7/1992 Knaub D6/707.21
D330,469 S * 10/1992 Brodbeck D6/643
5,438,937 A * 8/1995 Ball A47B 87/002
108/64
5,660,120 A * 8/1997 Sims A47B 21/00
108/50.02
D394,567 S * 5/1998 Hallenheim D6/693
D405,990 S * 2/1999 Peng-Hui D6/678.1

(Continued)

OTHER PUBLICATIONS

Interchange Wing Desk, hosted at Web.archive.org, posted on Mar. 16, 2015, online, site visited Oct. 19, 2017. Available from Internet: https://web.archive.org/web/20150316160200/http://smithsystem.com/furniture/wing-desk/#next.*

(Continued)

Primary Examiner — Mary Ann Calabrese

Assistant Examiner — Catherine Ho

(74) *Attorney, Agent, or Firm* — Brett J. Slaney; Blake, Cassels & Graydon LLP

(57)

CLAIM

The ornamental design of a table, as shown and described.

DESCRIPTION

FIG. 1 is a perspective view of the table;
FIG. 2 is top view of the table;
FIG. 3 is a bottom view of the table;
FIG. 4 is a side view of the table;
FIG. 5 is an opposite side view of the table;
FIG. 6 is a perspective view of the table showing an alternative configuration; and,
FIG. 7 is a perspective view of a component of the table isolated for clarity of illustration.
The even-spaced broken line portions of the figures are included to show portions of the article that form no part of the claimed design.

1 Claim, 7 Drawing Sheets

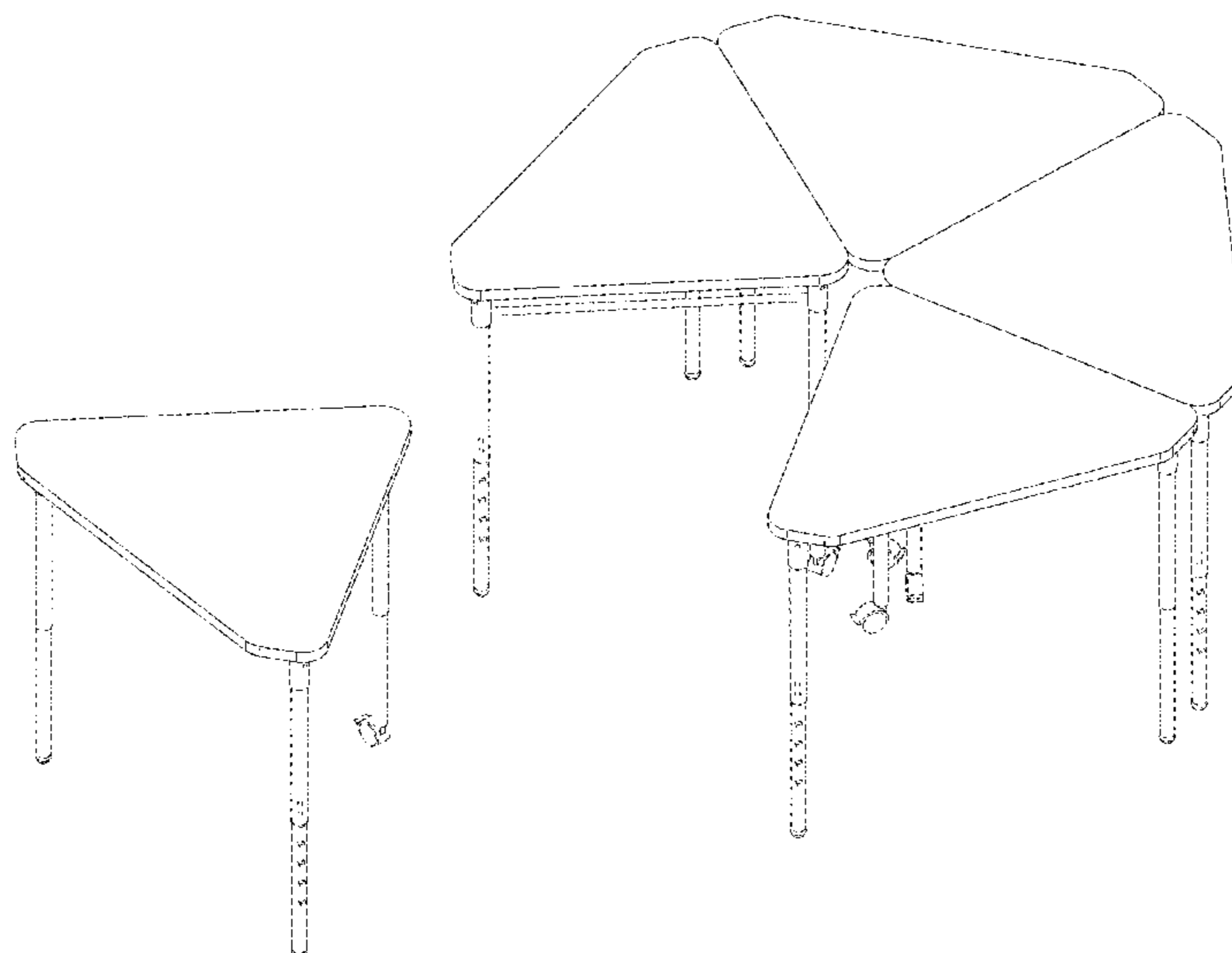

(56)

References Cited

U.S. PATENT DOCUMENTS

D413,212 S * 8/1999 Dame D6/650
D419,340 S * 1/2000 Swensson D6/696.1
D422,161 S * 4/2000 Pan D6/648.1
6,382,109 B1 * 5/2002 Novikoff A47B 87/002
108/65
7,311,047 B2 * 12/2007 Conley A47B 1/02
108/65
D608,118 S * 1/2010 Pini D6/690
D651,021 S * 12/2011 Etchells D6/669
D728,289 S * 5/2015 Pedrami D6/707.21
D834,861 S * 12/2018 Brooks D6/697
D834,865 S * 12/2018 Godwin D6/707.22
D839,648 S * 2/2019 Legare D6/707
2013/0129405 A1 * 5/2013 Everett A47B 13/088
403/66

OTHER PUBLICATIONS

UXL Diamond, hosted at Web.archive.org, posted on Mar. 16, 2015, online, site visited Oct. 19, 2017. Available from Internet: <https://web.archive.org/web/20150316164245/http://smithsystem.com/furniture/single-student-diamond-desk-2/>.*

Triangle Tables, posted at Behance.net, posted on May 16, 2014, online, site visited Oct. 19, 2017. Available from Internet: <https://www.behance.net/gallery/16941101/Triangle-Tables>.*

Modular School Desks, posted at Youtube.com, posted on Apr. 17, 2015, online, site visited Oct. 19, 2017. Available from Internet: <https://www.youtube.com/watch?v=-KcfHG91RxQ>.*

Balt Economy Shapes Desk & Essential Chair Package—Quo0007465 | Collaborative Des . . . ; www.worthingtondirect.com/desks/quo0005473-economy-shapes-desk-essential-chair-package-5-desks-5-16-h-chairs.htm; available online at least as early as Dec. 6, 2016.

* cited by examiner

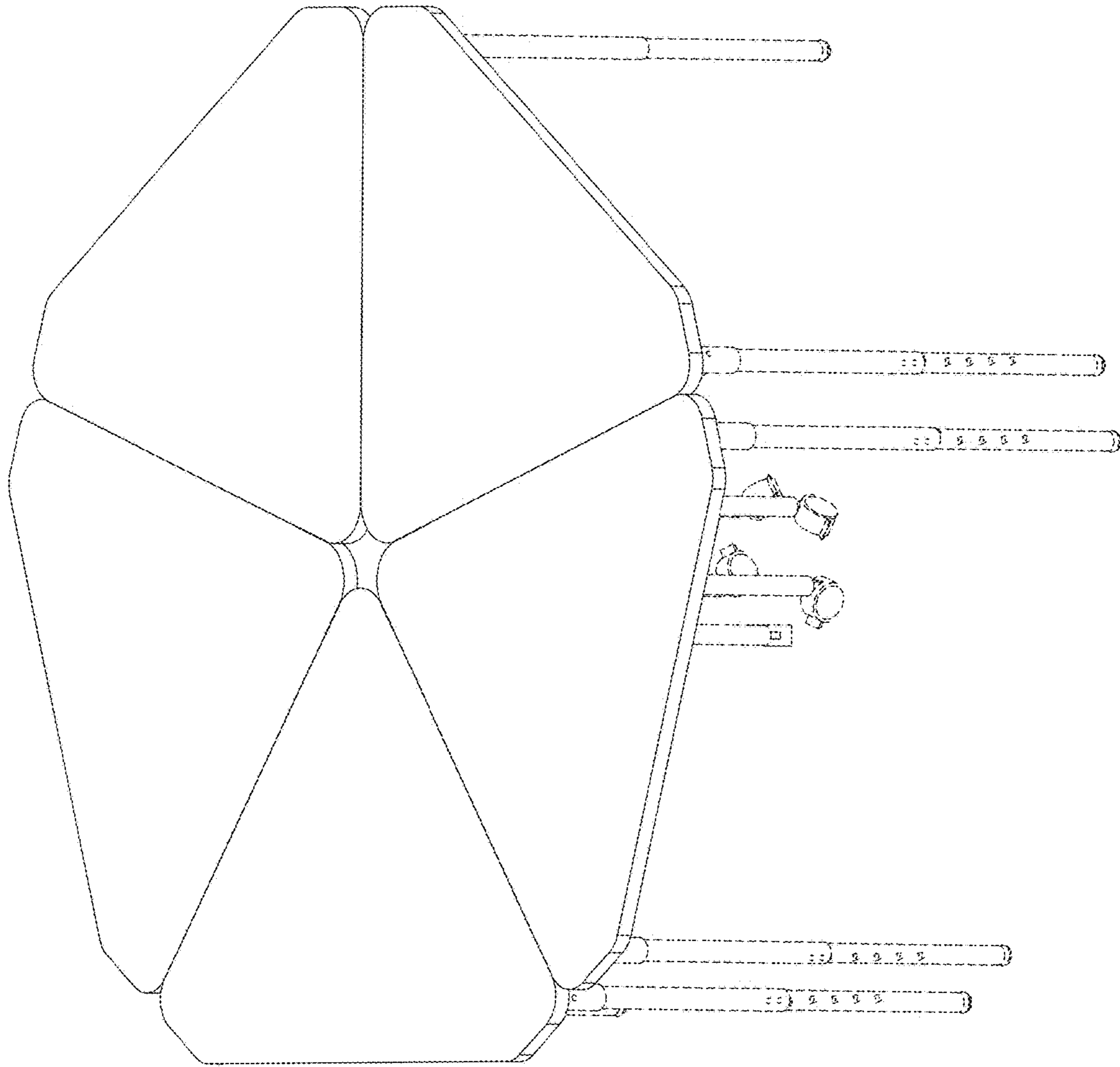

Fig. 1

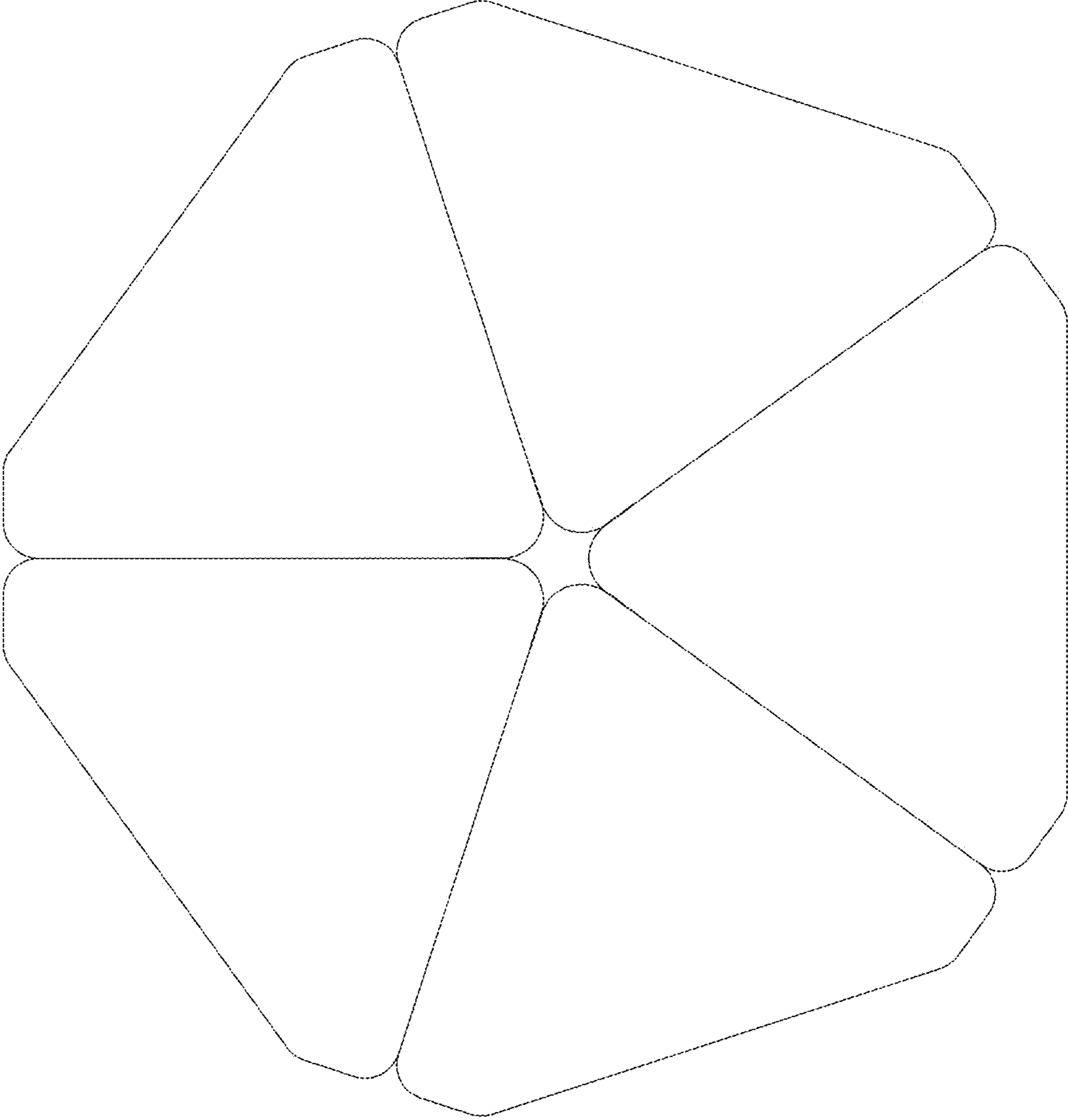

Fig. 2

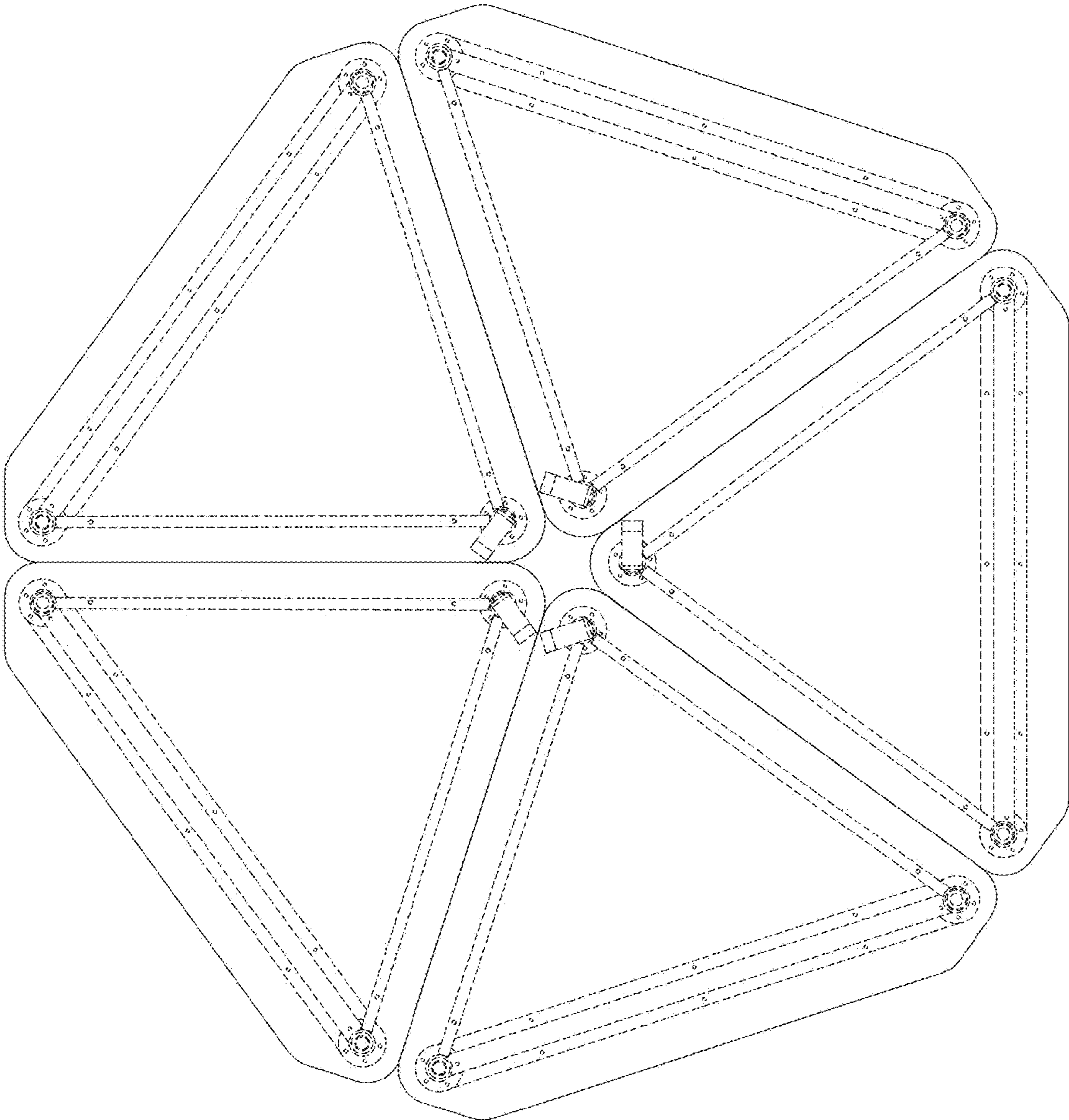

Fig. 3

Fig. 4

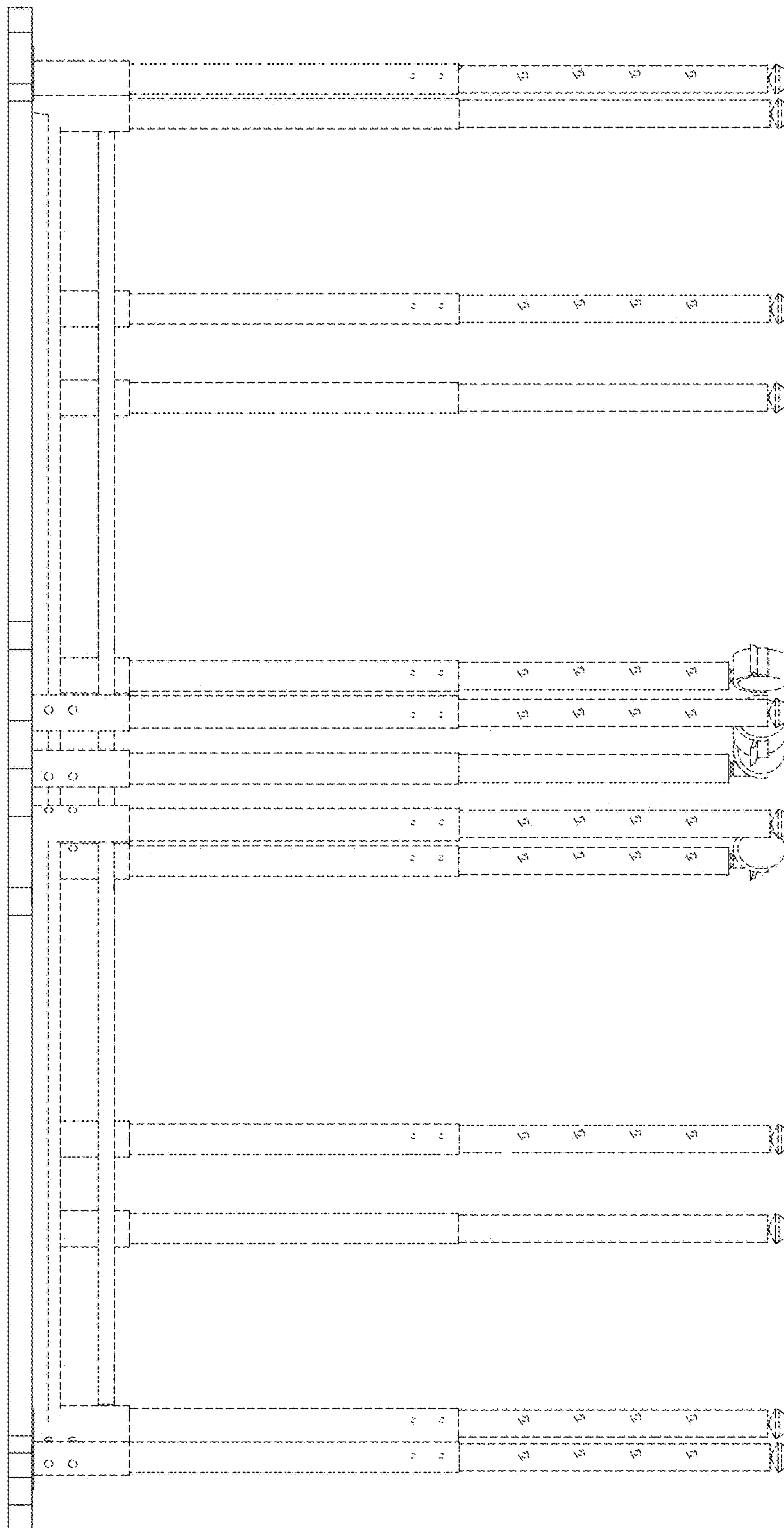
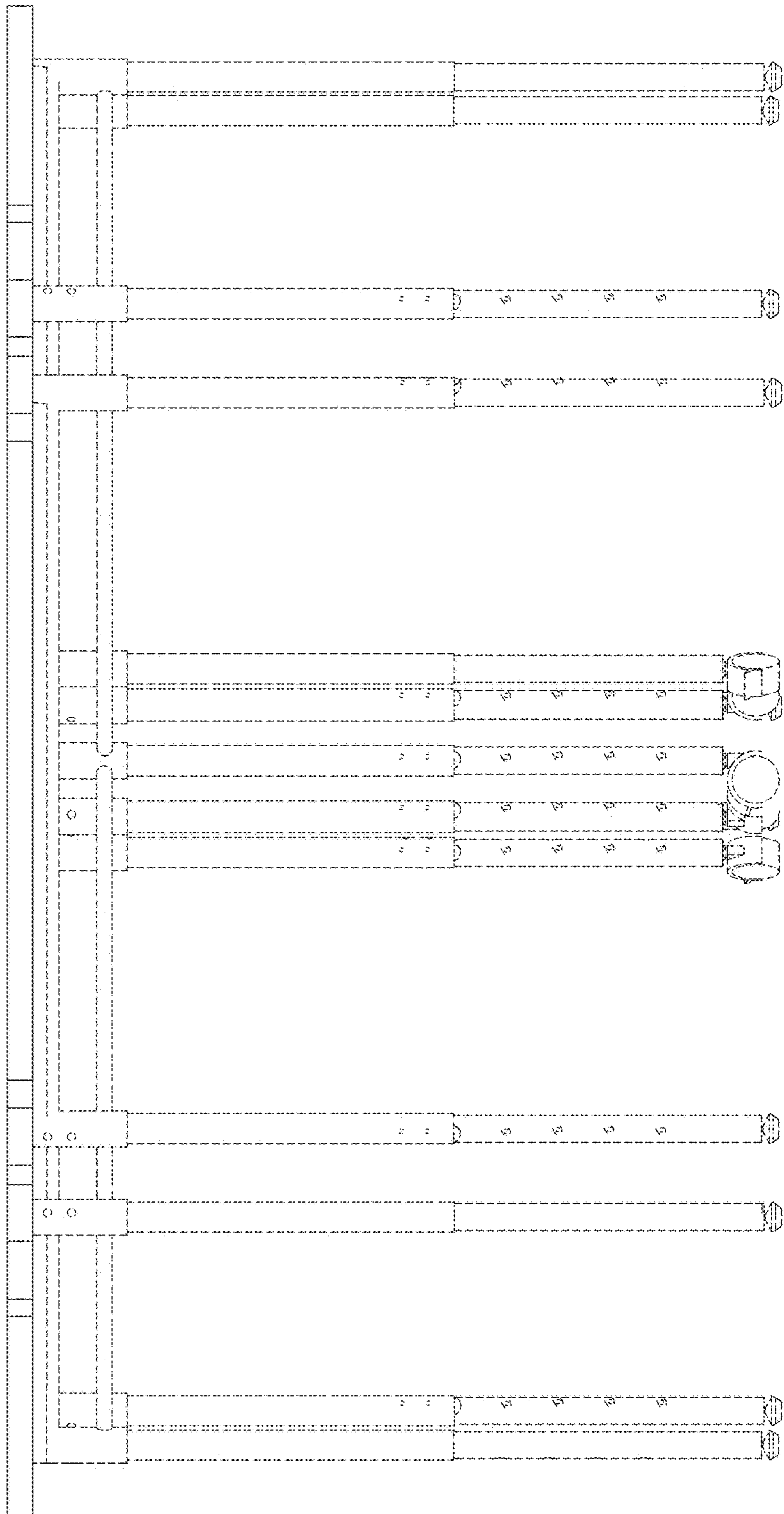

Fig. 5



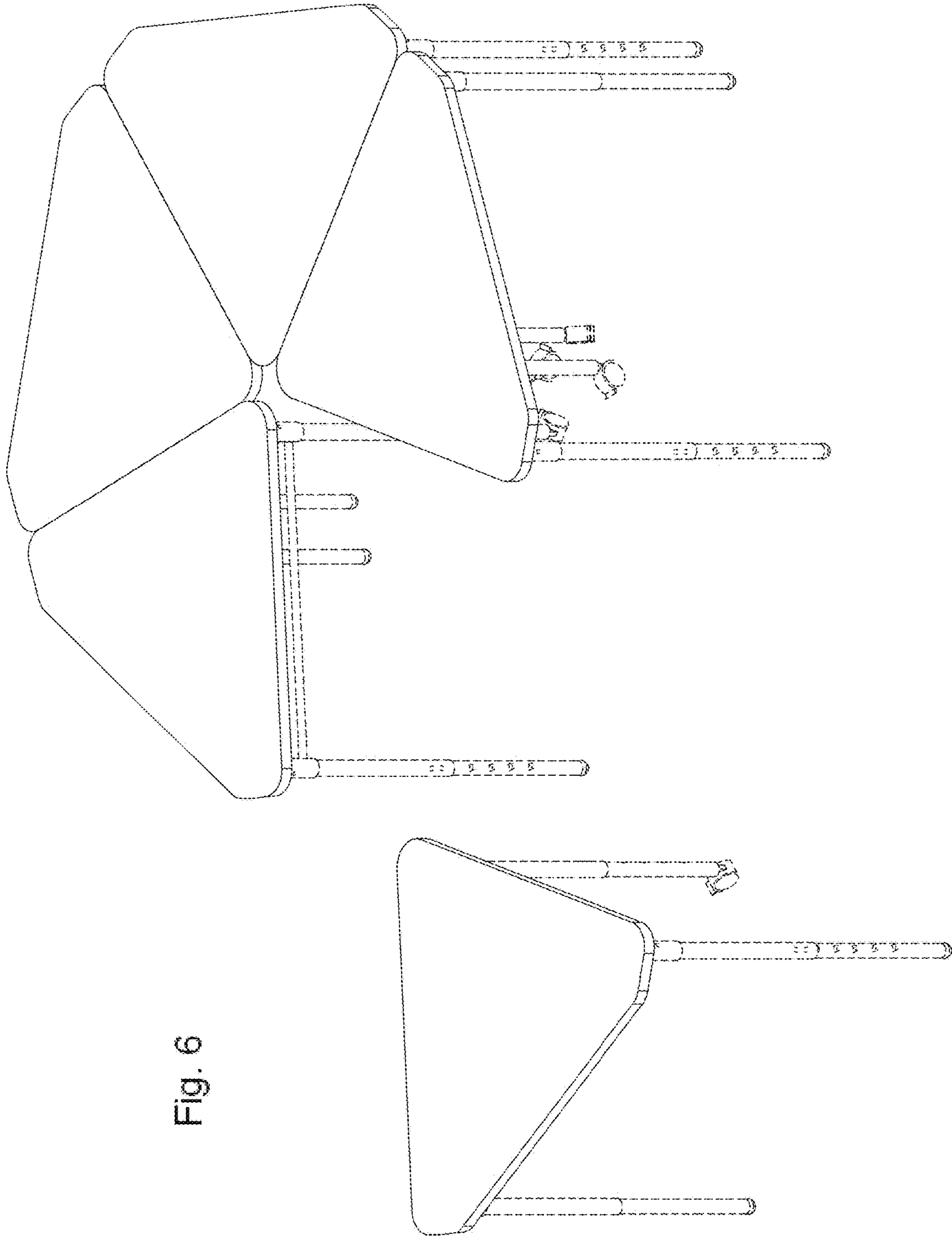

Fig. 6

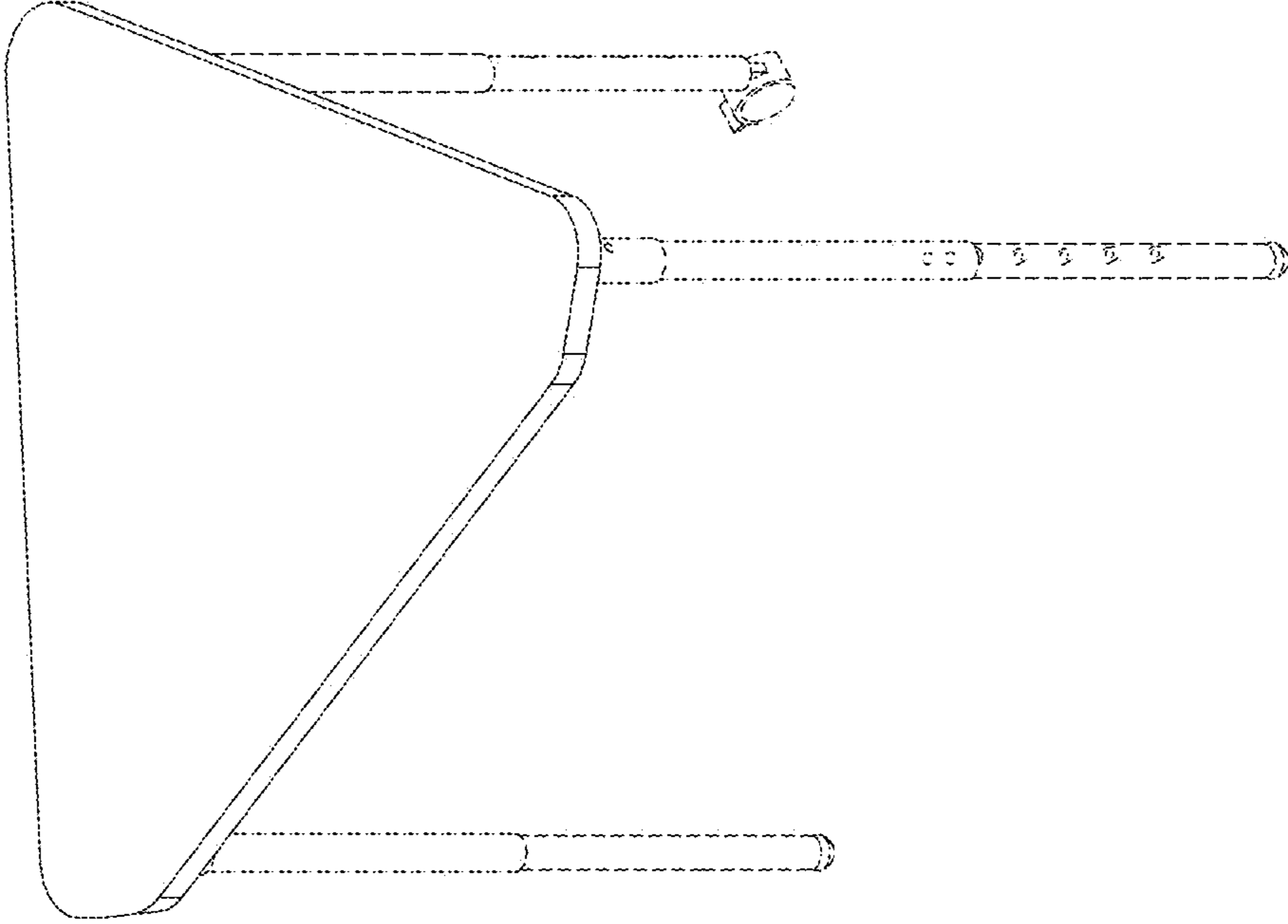

Fig. 7