



US00D860519S

(12) **United States Design Patent**  
**Cividi**

(10) **Patent No.:** **US D860,519 S**

(45) **Date of Patent:** **\*\* Sep. 17, 2019**

(54) **VAPING DEVICE**

(71) Applicant: **Santosh Cividi**, Sugar Land, TX (US)

(72) Inventor: **Santosh Cividi**, Sugar Land, TX (US)

(\*\*) Term: **15 Years**

(21) Appl. No.: **29/636,728**

(22) Filed: **Feb. 10, 2018**

(51) **LOC (12) Cl.** ..... **27-02**

(52) **U.S. Cl.**  
USPC ..... **D27/162**

(58) **Field of Classification Search**

USPC ..... D27/100, 101, 139-161, 162-194;  
D23/366; D7/416; D24/110; D19/101,  
D19/106, 115, 165, 195; D14/435.1;  
D13/108

CPC ..... A24F 47/008; A24F 47/002; A24F 7/00;  
A24F 15/12

See application file for complete search history.

(56) **References Cited**

**U.S. PATENT DOCUMENTS**

D257,519 S \* 11/1980 Plozner ..... D27/154  
D259,062 S \* 4/1981 Stutzer ..... D27/154  
D474,306 S \* 5/2003 Chemla ..... D27/154

(Continued)

*Primary Examiner* — Marissa J Cash

(74) *Attorney, Agent, or Firm* — Craft Chu PLLC;  
Andrew W. Chu

(57) **CLAIM**

The ornamental design for a vaping device, as shown and described.

**DESCRIPTION**

FIG. 1 is an upper perspective view of the vaping device showing my design in an assembled configuration;

FIG. 2 is a front elevation view thereof;  
FIG. 3 is a back elevation view thereof;  
FIG. 4 is a side elevation view thereof;  
FIG. 5 is an opposite side elevation view thereof;  
FIG. 6 is a top plan view thereof;  
FIG. 7 is a bottom plan view thereof;  
FIG. 8 is another upper perspective view thereof in an exploded configuration for a cartridge, shaft, and charger of the vaping device with a charge cap in broken lines;  
FIG. 9 is still another upper perspective view thereof in a partially exploded configuration for the cartridge and the shaft separated from the charger with a shaft cap in broken lines;  
FIG. 10 is an upper perspective view of the charger of the vaping device;  
FIG. 11 is a front elevation view of the charger;  
FIG. 12 is a back elevation view of the charger;  
FIG. 13 is a side elevation view of the charger;  
FIG. 14 is an opposite side elevation view of the charger;  
FIG. 15 is a top plan view of the charger;  
FIG. 16 is a bottom plan view of the charger;  
FIG. 17 is an upper perspective view of the shaft of the vaping device;  
FIG. 18 is a front elevation view of the shaft;  
FIG. 19 is a back elevation view of the shaft;  
FIG. 20 is a side elevation view of the shaft;  
FIG. 21 is an opposite side elevation view of the shaft;  
FIG. 22 is a top plan view of the shaft;  
FIG. 23 is a bottom plan view of the shaft;  
FIG. 24 is an upper perspective view of the cartridge of the vaping device;  
FIG. 25 is a front elevation view of the cartridge;  
FIG. 26 is a back elevation view of the cartridge;  
FIG. 27 is a side elevation view of the cartridge;  
FIG. 28 is an opposite side elevation view of the cartridge;  
FIG. 29 is a top plan view of the cartridge; and,  
FIG. 30 is a bottom plan view of the cartridge.  
The broken lines in the drawings represent unclaimed environmental subject matter and form no part of the claimed design.

**1 Claim, 7 Drawing Sheets**

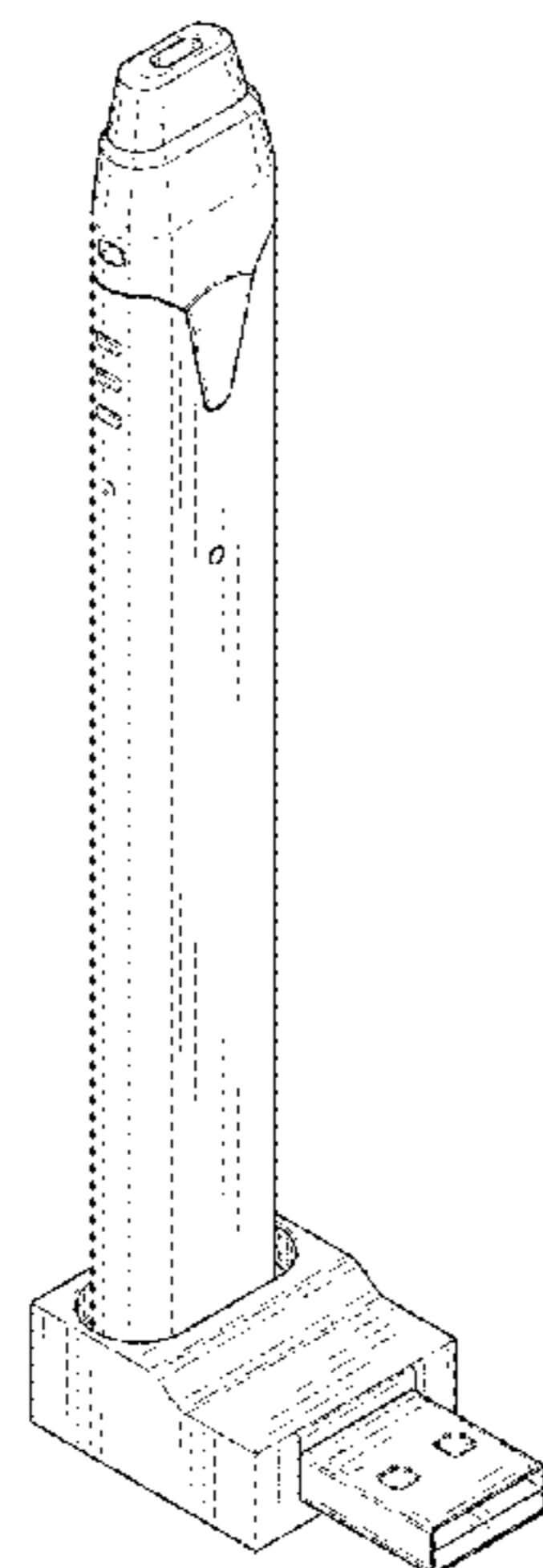

(56)

References Cited

U.S. PATENT DOCUMENTS

D532,927 S \* 11/2006 Sann ..... D27/101  
 D615,699 S \* 5/2010 Vordenberg ..... D27/102  
 D625,465 S \* 10/2010 Clavero ..... D27/154  
 D644,375 S 8/2011 Zhou  
 D645,817 S \* 9/2011 Sasada ..... D13/108  
 D675,777 S \* 2/2013 Wu ..... D27/101  
 D685,522 S 7/2013 Potter  
 D688,416 S 8/2013 Liu  
 D721,202 S \* 1/2015 Liu ..... D27/101  
 D725,310 S \* 3/2015 Eksouzian ..... D27/101  
 D725,821 S \* 3/2015 Levin ..... D27/101  
 D729,439 S 5/2015 Scatterday  
 D744,419 S \* 12/2015 Bowen ..... D13/108  
 D750,320 S \* 2/2016 Verleur ..... A24F 47/008  
 D752,284 S \* 3/2016 Doster ..... D27/189  
 D756,030 S \* 5/2016 Chen ..... D27/101  
 D759,303 S \* 6/2016 Afridi ..... D27/101  
 D760,948 S \* 7/2016 Eksouzian ..... D27/101  
 D762,003 S \* 7/2016 Lomeli ..... D27/163  
 D773,727 S \* 12/2016 Eksouzian ..... D27/101  
 D775,412 S \* 12/2016 Di Bari ..... D27/101  
 D776,337 S \* 1/2017 Levin ..... D27/101  
 D776,338 S \* 1/2017 Lomeli ..... D27/163  
 D776,869 S \* 1/2017 Heidl ..... D27/163  
 D778,493 S \* 2/2017 Scott ..... D27/101  
 D779,719 S \* 2/2017 Qiu ..... D27/101  
 D784,610 S \* 4/2017 Bosch ..... D27/101  
 D790,680 S \* 6/2017 Afridi ..... D23/366  
 D792,021 S \* 7/2017 Beer ..... D27/101  
 D792,643 S \* 7/2017 Wong ..... D27/101  
 D799,110 S \* 10/2017 Qiu ..... D27/101  
 D799,112 S \* 10/2017 Qiu ..... D27/101  
 D799,113 S \* 10/2017 Qiu ..... D27/101  
 D799,744 S \* 10/2017 Qiu ..... D27/101  
 D805,248 S \* 12/2017 Chen ..... D27/170  
 D805,684 S \* 12/2017 Thuery ..... D27/101  
 D807,575 S \* 1/2018 Luo ..... D27/141

D808,071 S \* 1/2018 Folkerts ..... D27/101  
 D811,003 S \* 2/2018 Folyan ..... D27/101  
 D813,447 S \* 3/2018 Watson ..... D27/162  
 D815,341 S \* 4/2018 Qiu ..... D27/101  
 D818,636 S \* 5/2018 Qiu ..... D27/101  
 D819,263 S \* 5/2018 Zhu ..... D27/101  
 D819,881 S \* 6/2018 Qiu ..... D27/101  
 D822,271 S \* 7/2018 Eksouzian ..... D27/101  
 D822,896 S \* 7/2018 Durand ..... D27/101  
 D825,099 S \* 8/2018 Wright ..... D27/101  
 D825,102 S \* 8/2018 Bowen ..... D27/167  
 D825,834 S \* 8/2018 Chen ..... D27/101  
 D827,195 S \* 8/2018 Chen ..... D27/101  
 D829,371 S \* 9/2018 Durand ..... D27/101  
 D829,372 S \* 9/2018 Huang ..... D27/101  
 D829,373 S \* 9/2018 Huang ..... D27/101  
 D829,980 S \* 10/2018 Qiu ..... D27/162  
 D830,298 S \* 10/2018 Bailey ..... D13/108  
 D832,499 S \* 10/2018 Qiu ..... D27/162  
 D832,500 S \* 10/2018 Qiu ..... D27/162  
 D833,064 S \* 11/2018 Verleur ..... D27/172  
 D834,246 S \* 11/2018 Qiu ..... D27/162  
 D835,337 S \* 12/2018 Beer ..... D27/162  
 D836,831 S \* 12/2018 Cividi ..... D27/162  
 D836,834 S \* 12/2018 Cividi ..... D27/194  
 D837,446 S \* 1/2019 Durand ..... D27/101  
 D838,899 S \* 1/2019 Qiu ..... D27/167  
 D844,235 S \* 3/2019 Cividi ..... D27/167  
 2015/0034104 A1 \* 2/2015 Zhou ..... A24F 47/008  
 131/329  
 2016/0345626 A1 \* 12/2016 Wong ..... A24F 47/008  
 2017/0258142 A1 \* 9/2017 Hatton ..... A24F 47/008  
 2017/0259170 A1 \* 9/2017 Bowen ..... A24F 47/008  
 2018/0043114 A1 \* 2/2018 Bowen ..... A61M 15/003  
 2018/0077967 A1 \* 3/2018 Hatton ..... A61M 11/042  
 2018/0098571 A1 \* 4/2018 Watson ..... A24F 47/008  
 2018/0153221 A1 \* 6/2018 Verleur ..... A24F 47/008  
 2018/0213847 A1 \* 8/2018 Reeve ..... A24F 47/008  
 2018/0279674 A1 \* 10/2018 Watson ..... A24F 7/02  
 2018/0279682 A1 \* 10/2018 Guo ..... A24F 47/008

\* cited by examiner

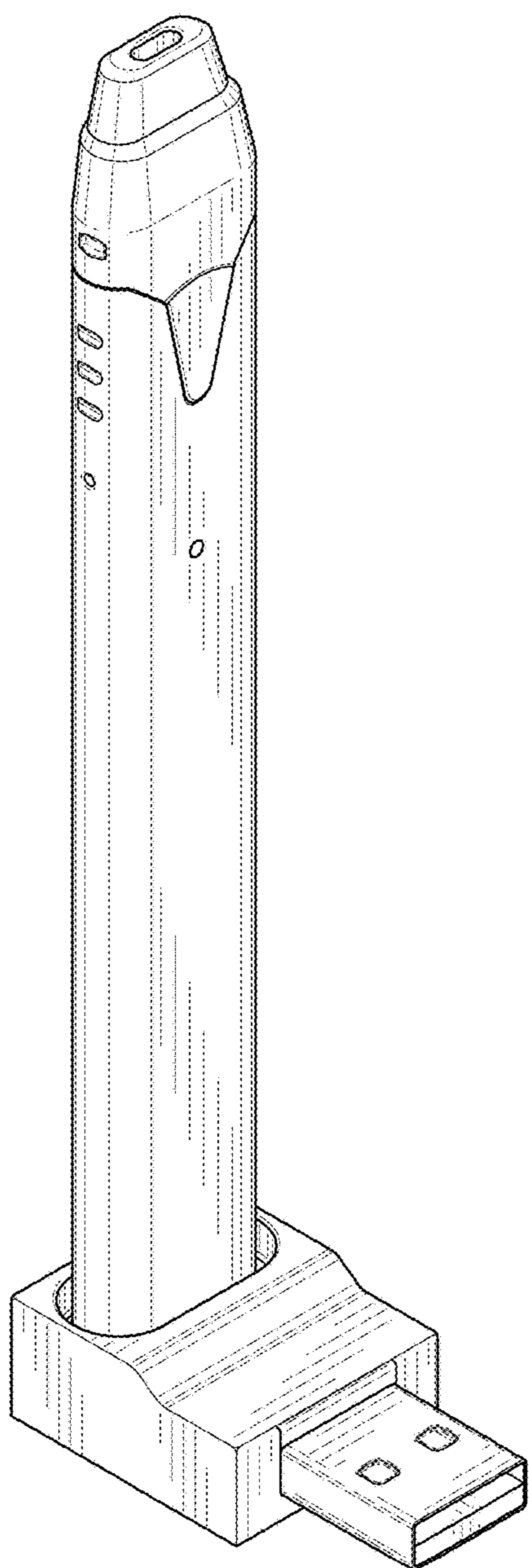

FIG. 1

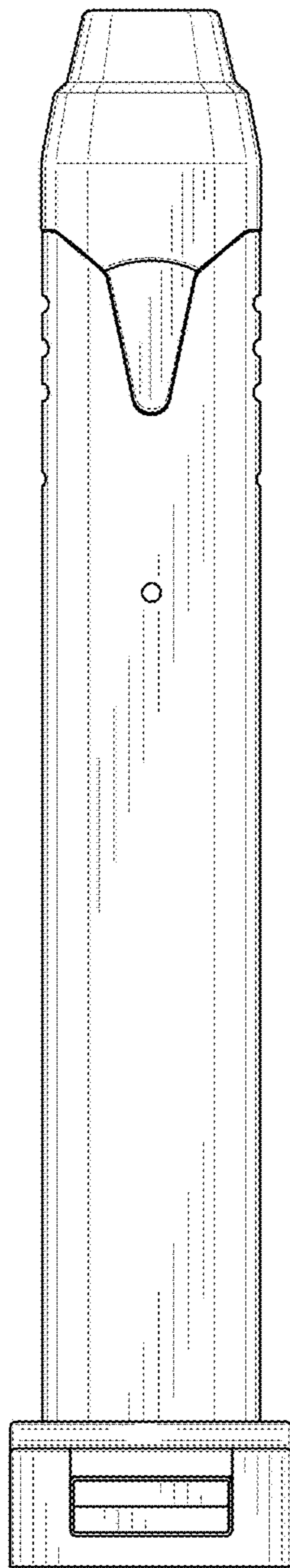

FIG. 2

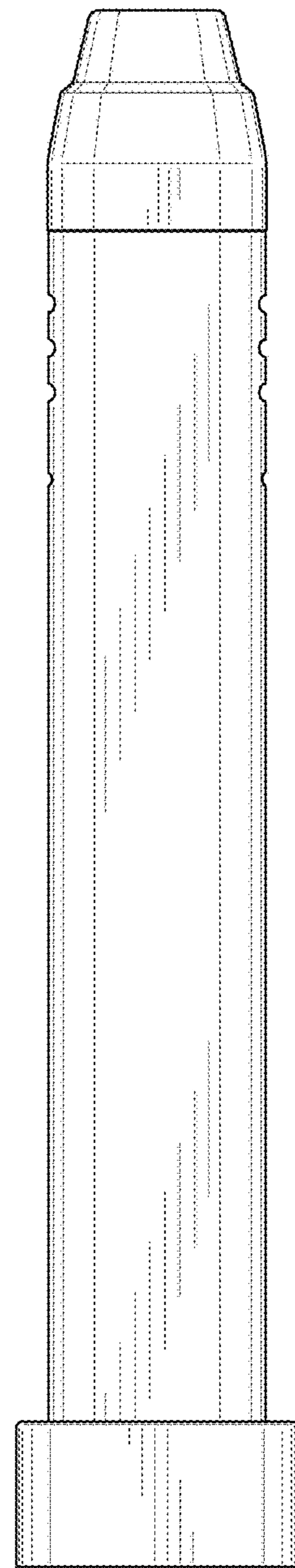

FIG. 3

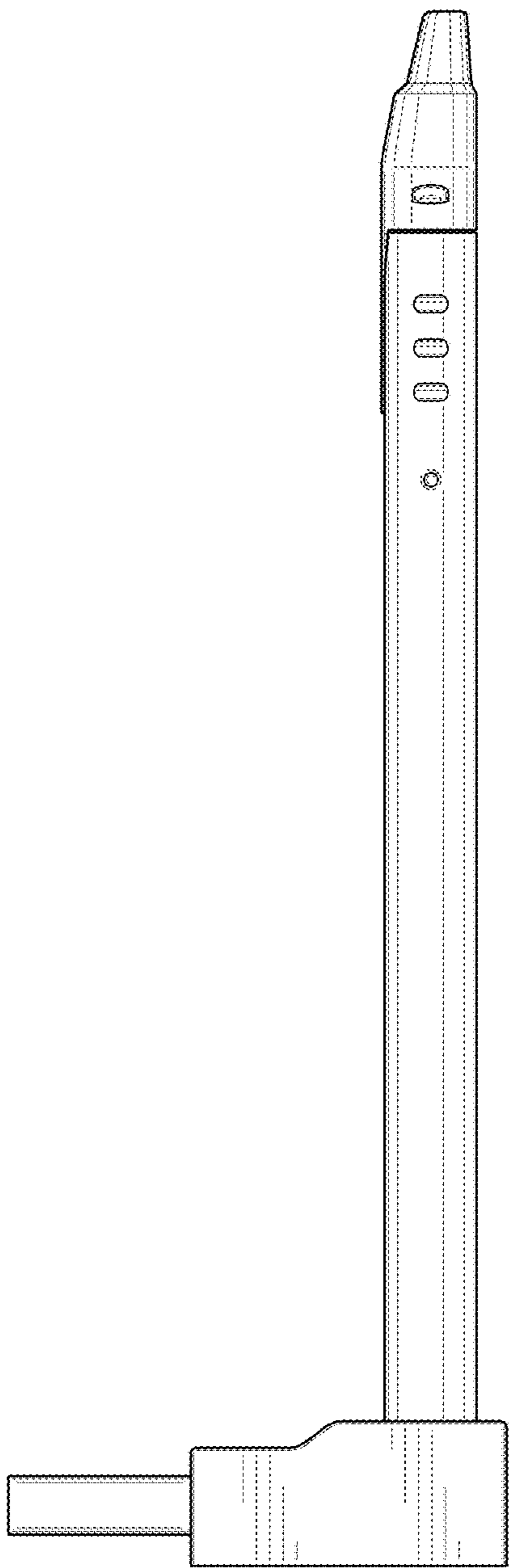

FIG. 4

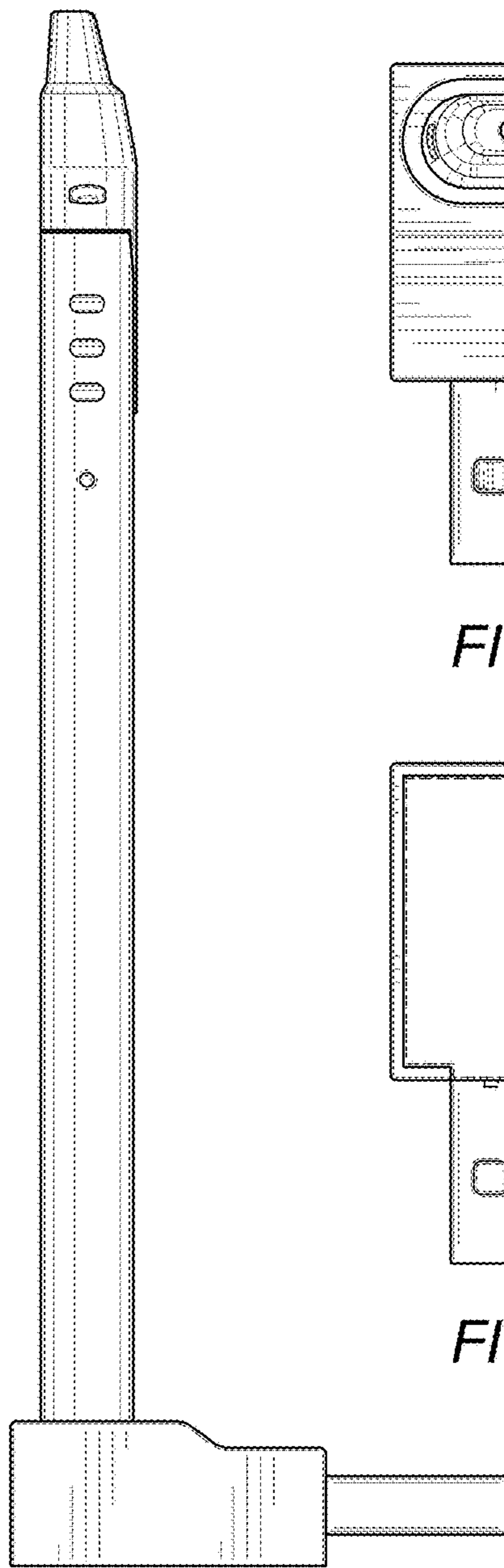

FIG. 5

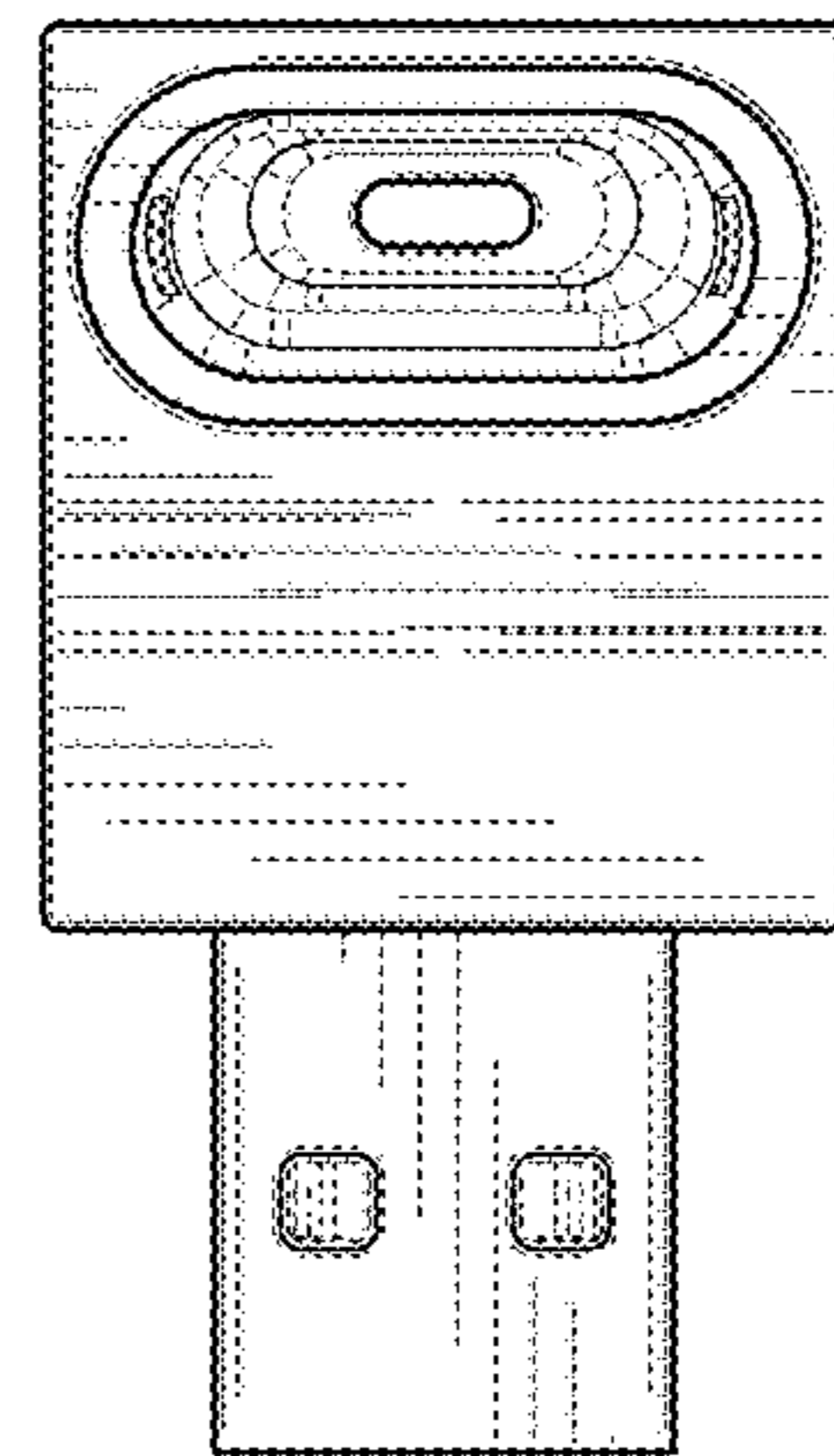

FIG. 6

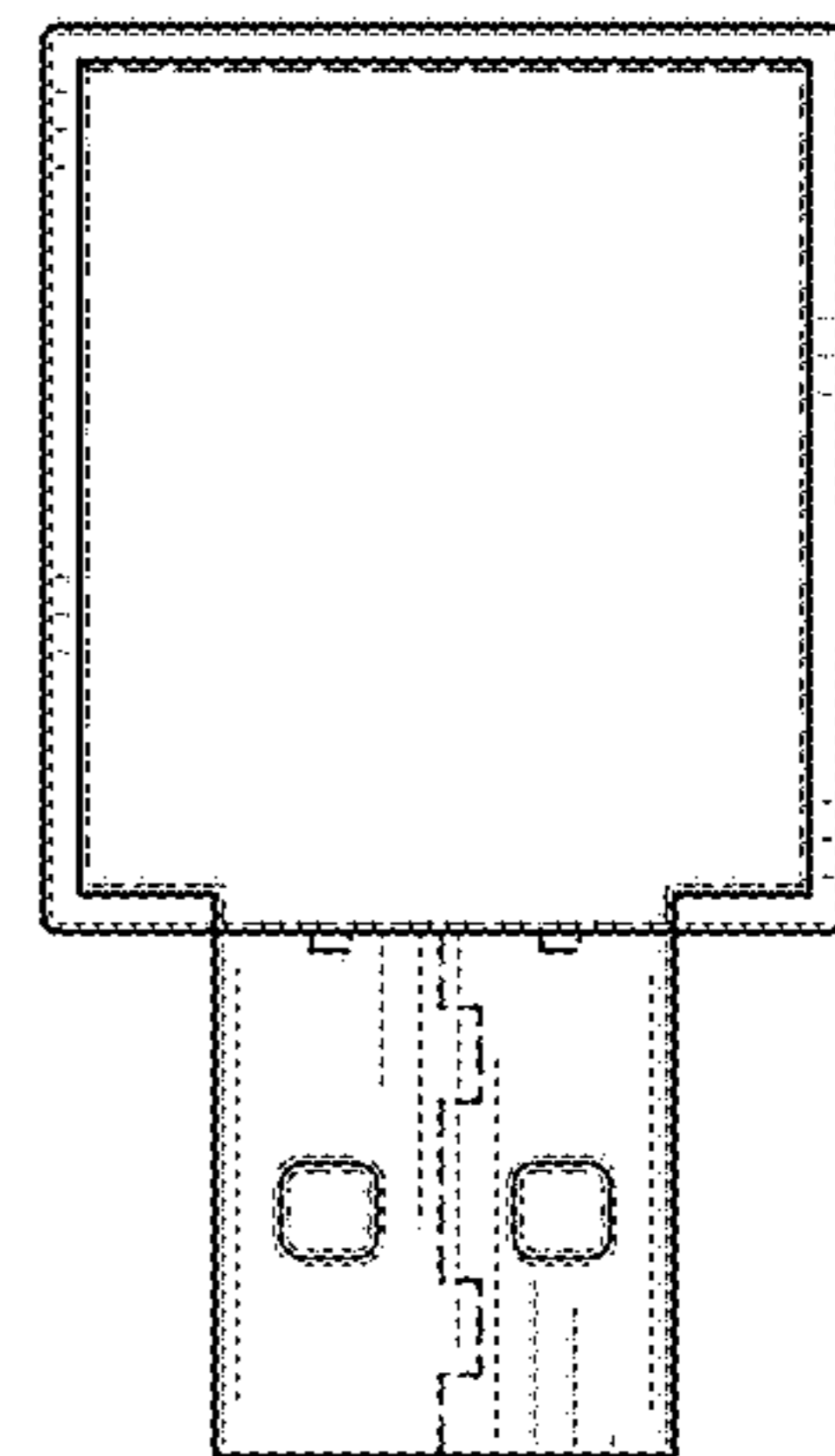

FIG. 7

FIG. 8

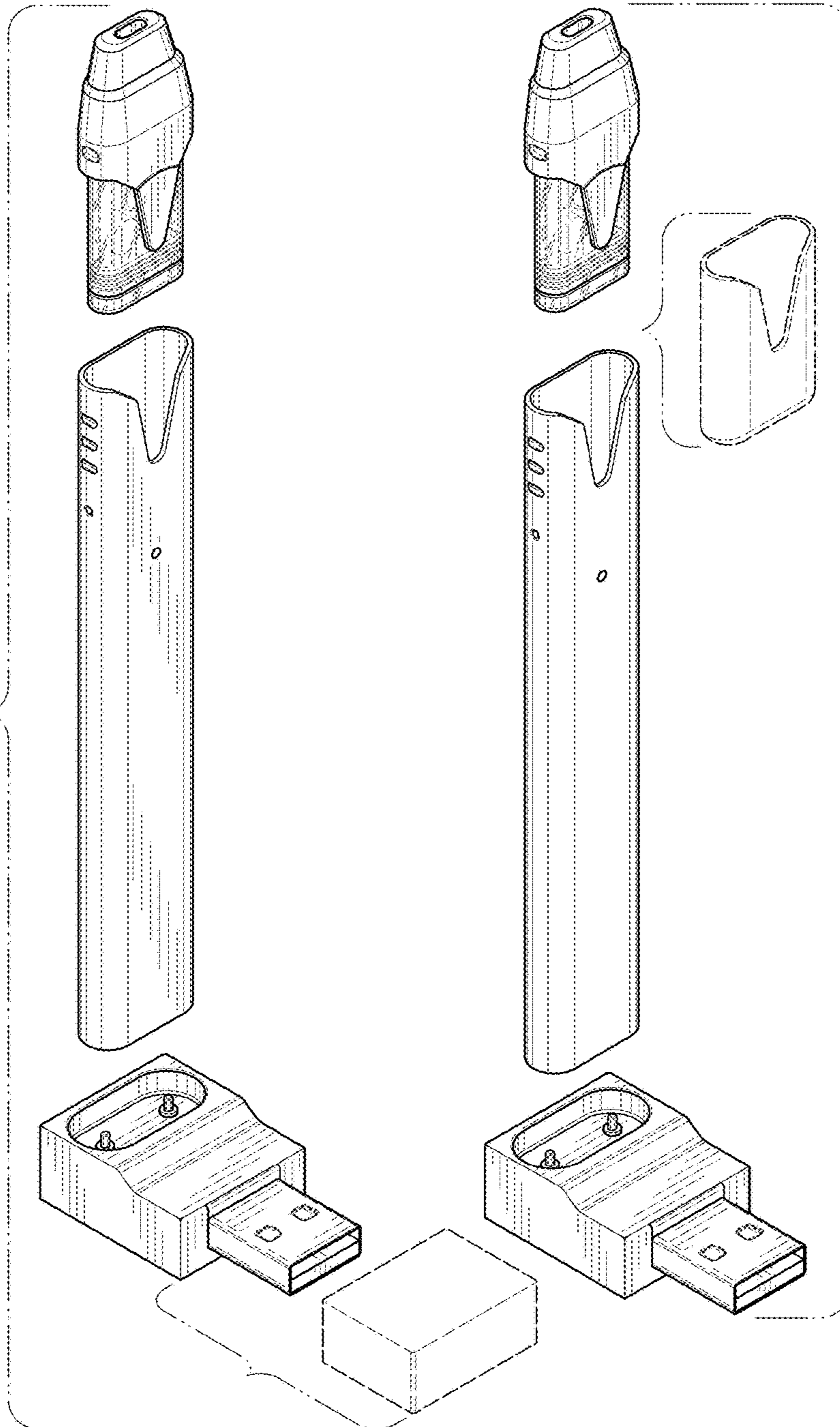
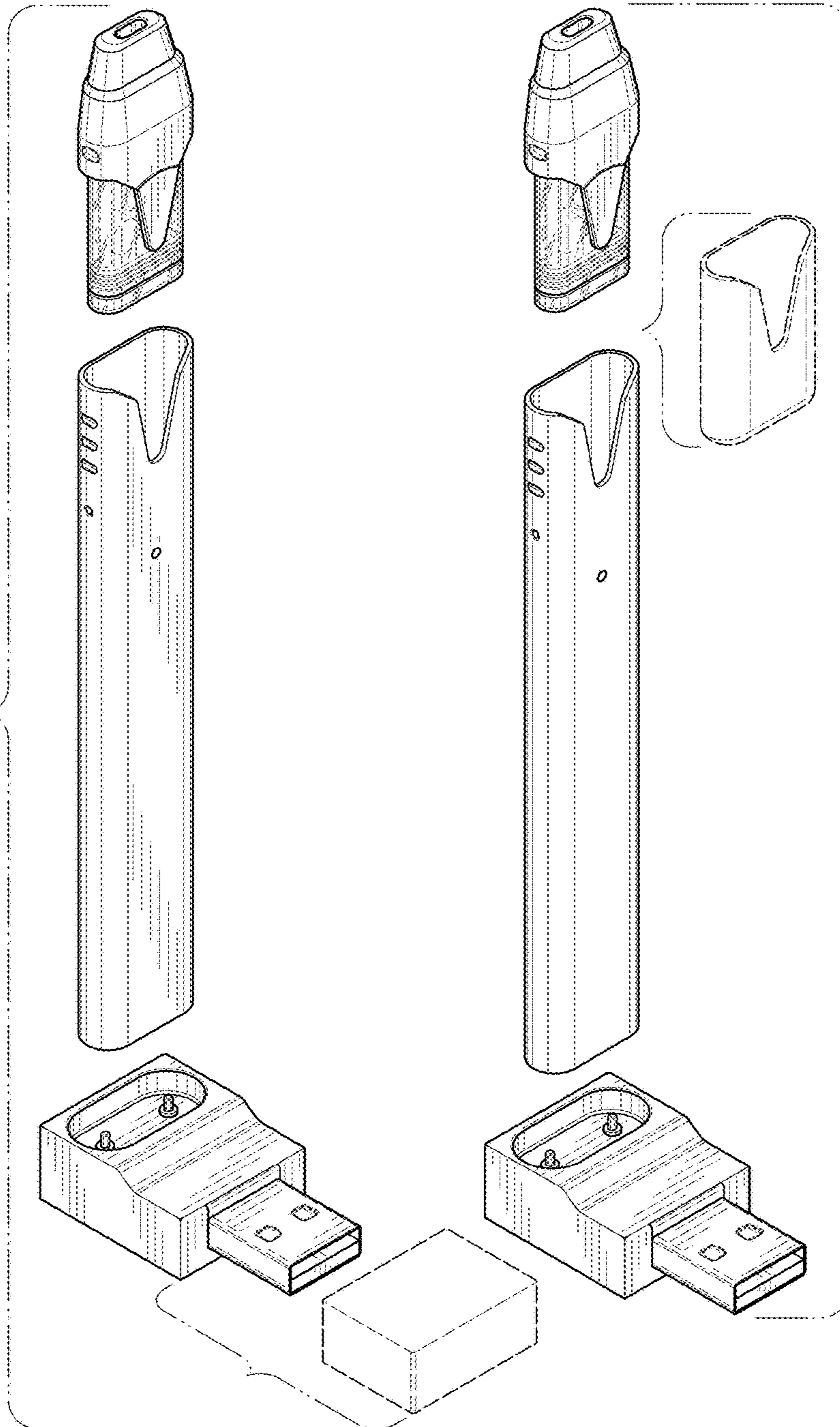

FIG. 9



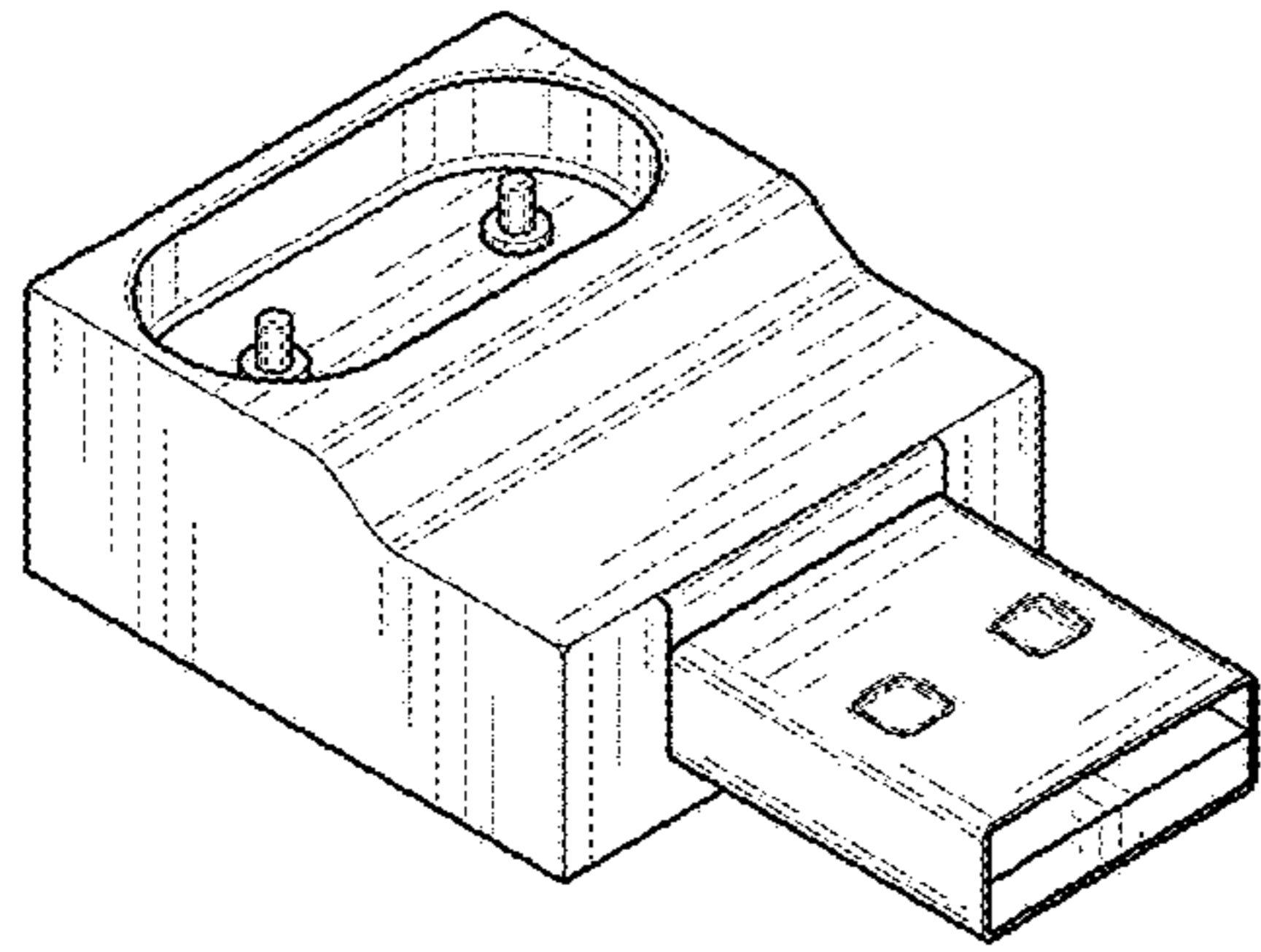

FIG. 10

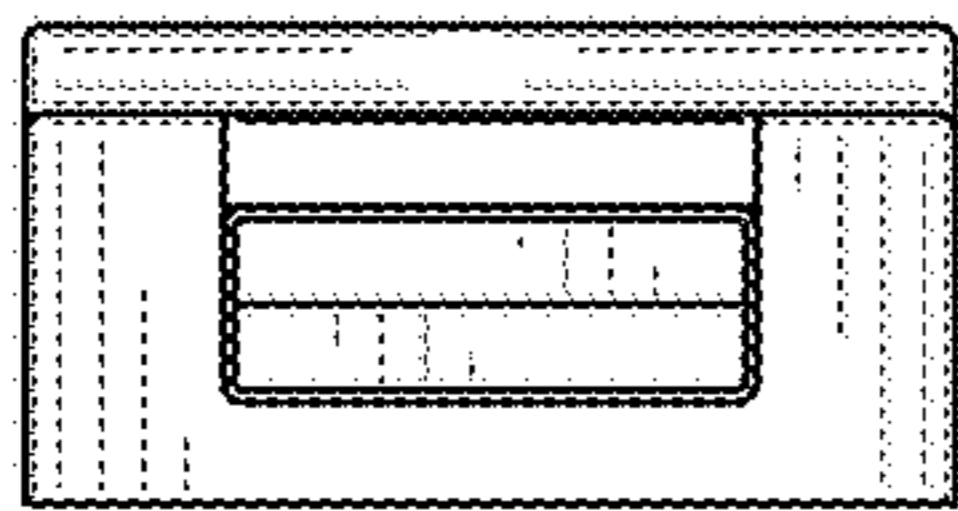

FIG. 11

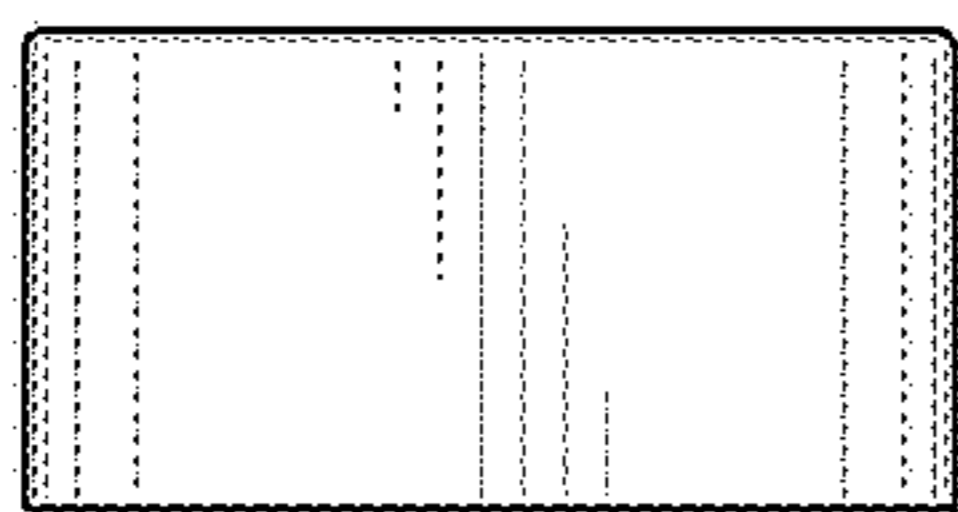

FIG. 12

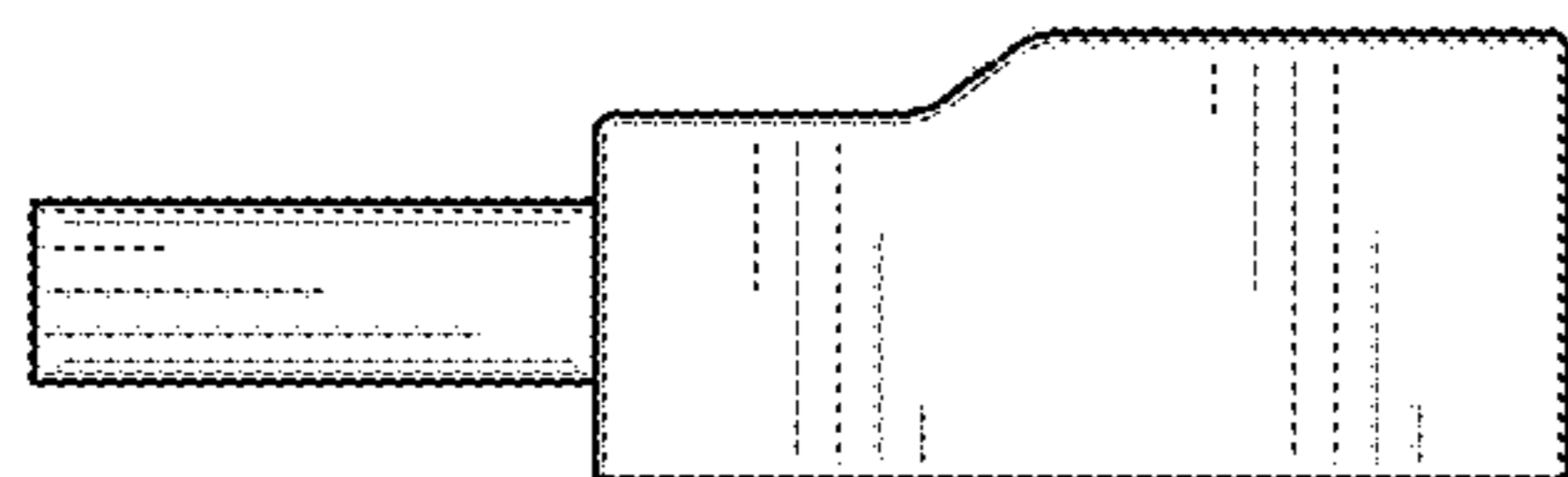

FIG. 13

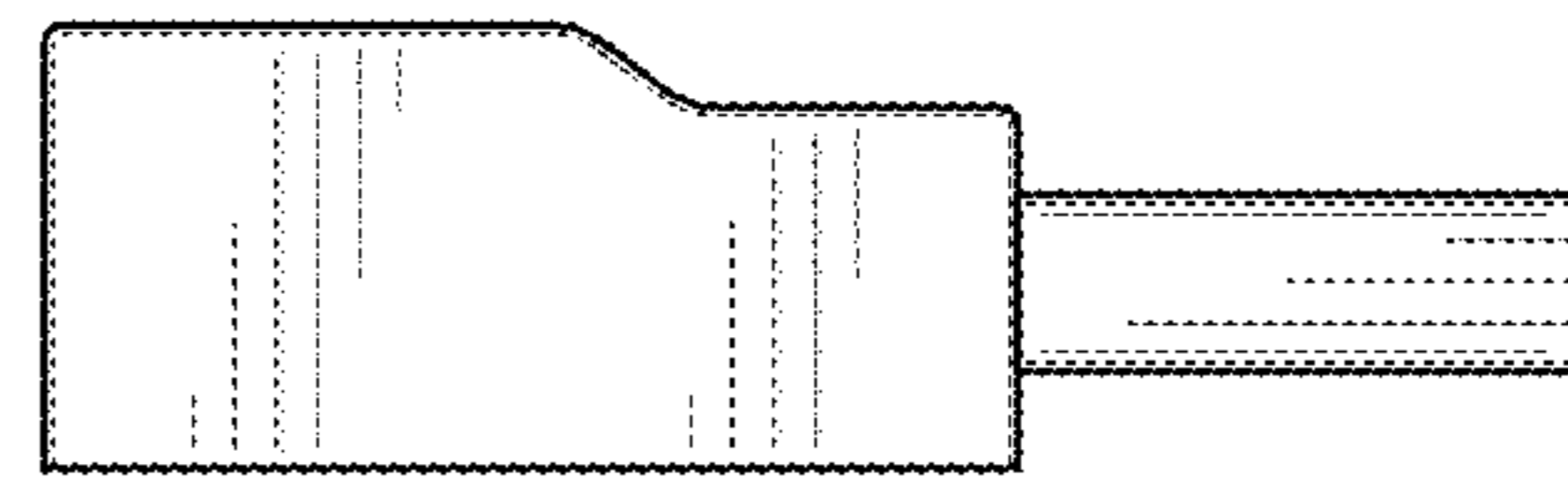

FIG. 14

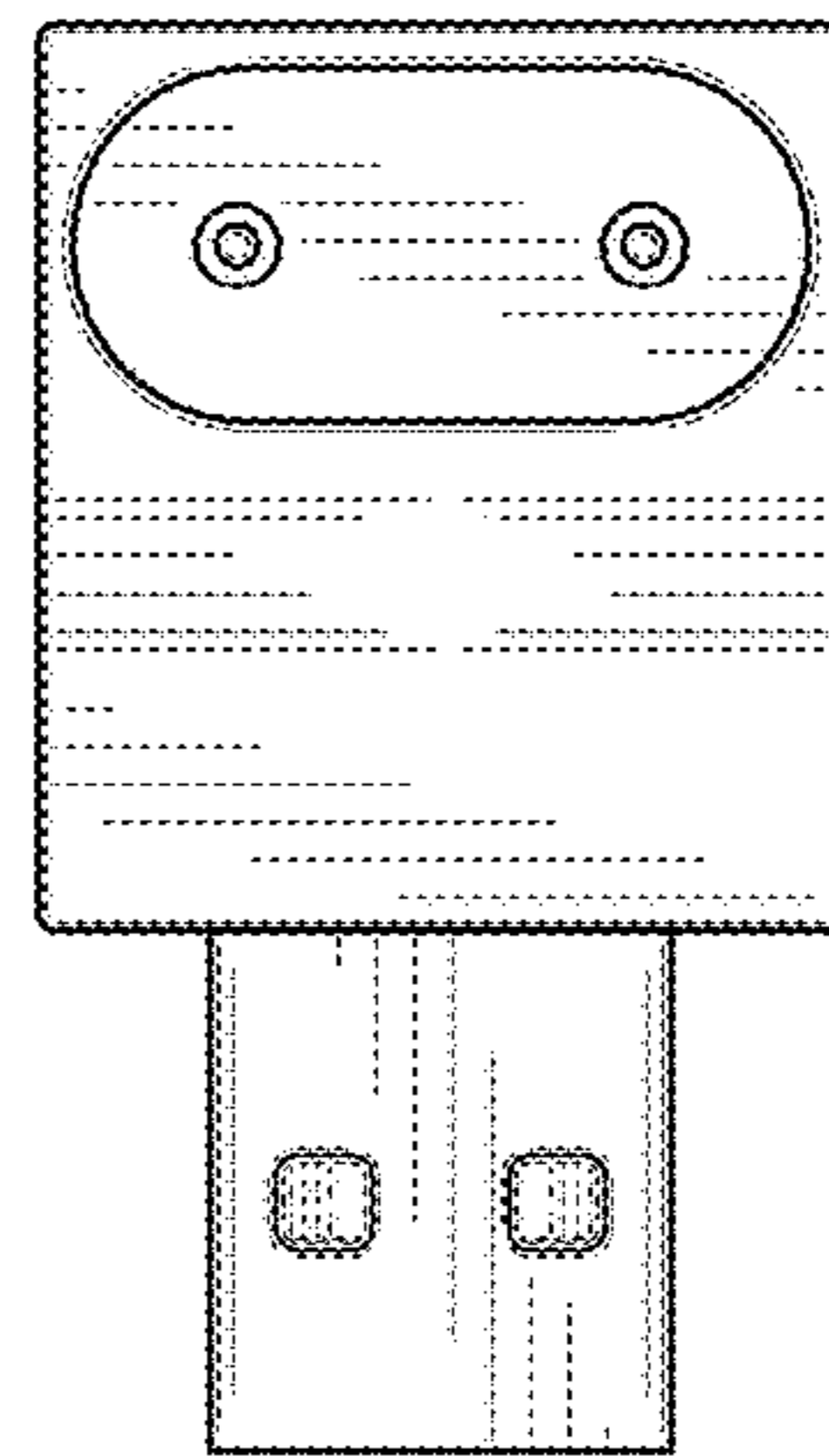

FIG. 15

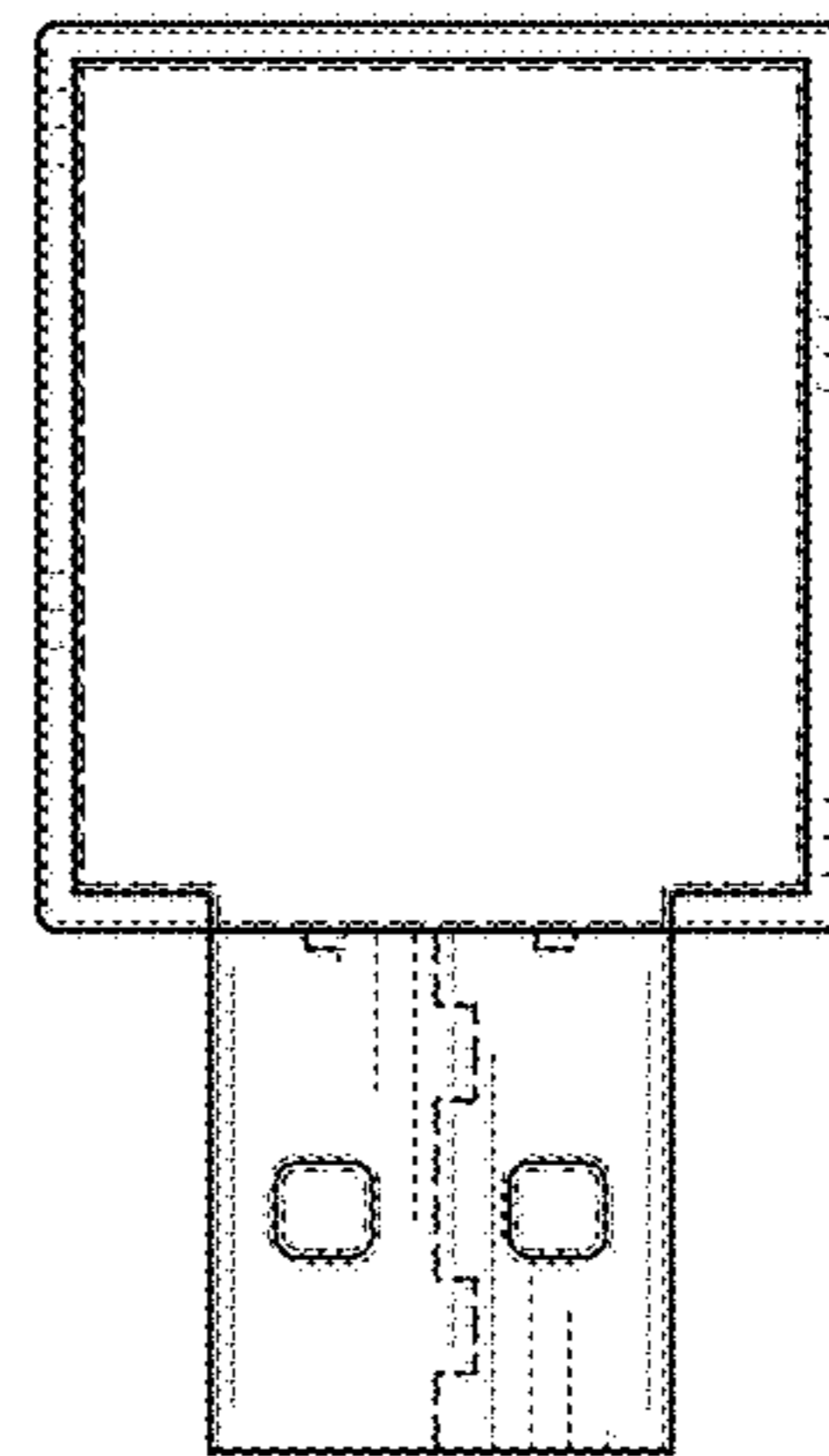

FIG. 16

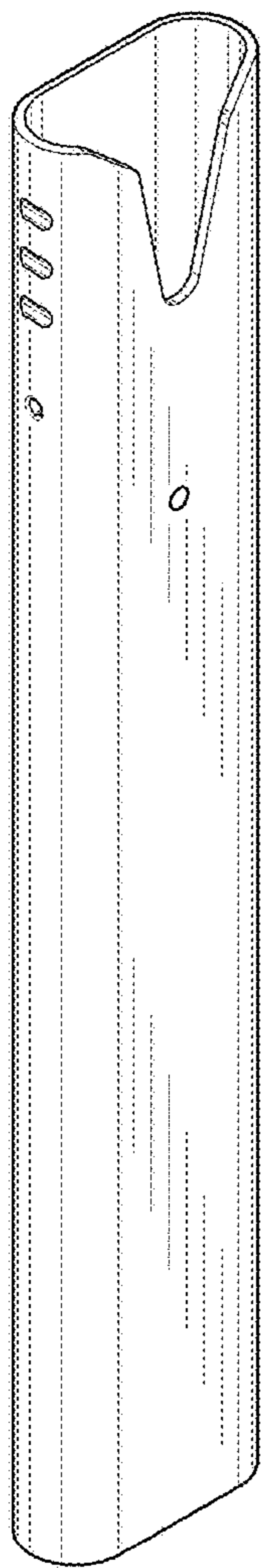

FIG. 17

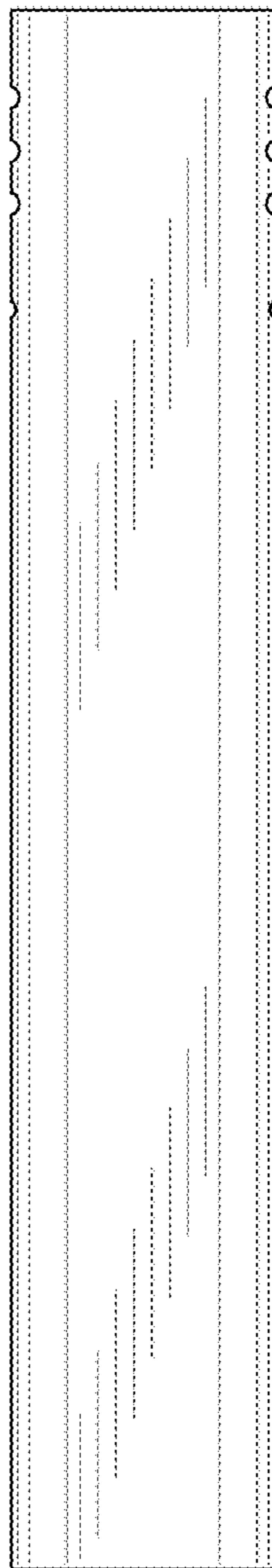

FIG. 18

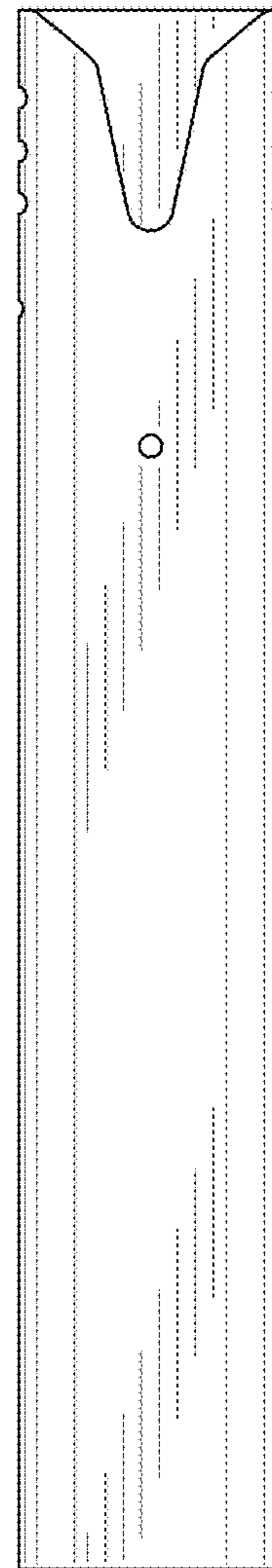

FIG. 19

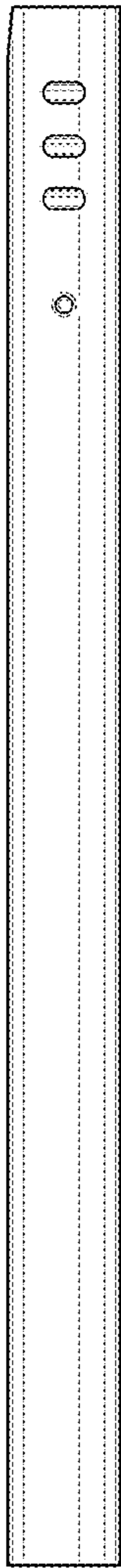

FIG. 20

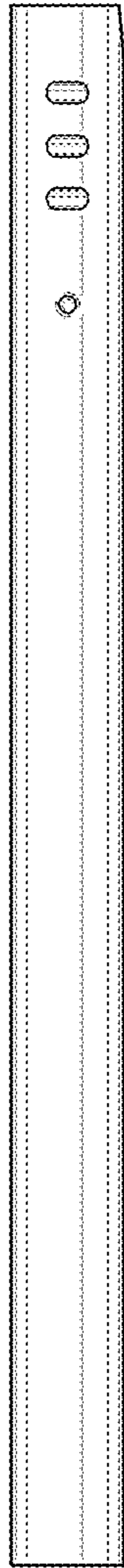

FIG. 21



FIG. 22

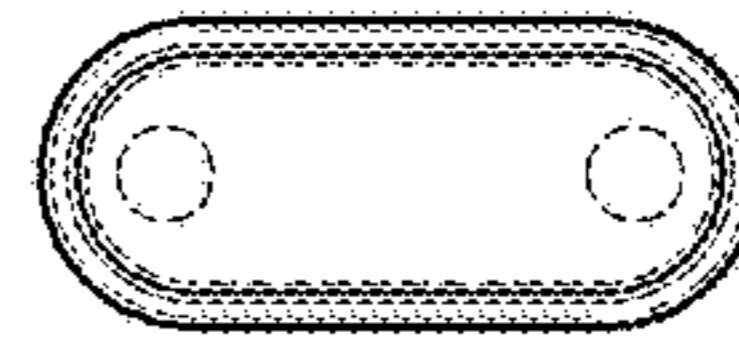

FIG. 23



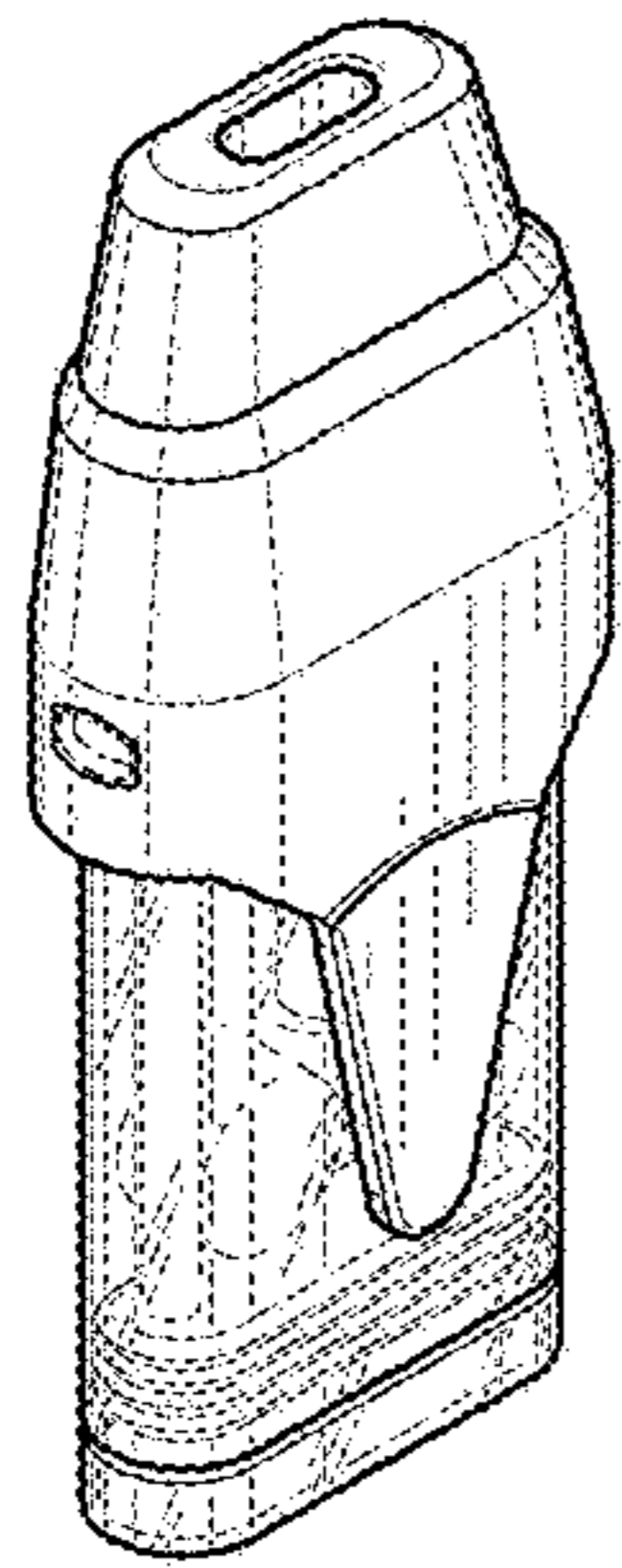

FIG. 24

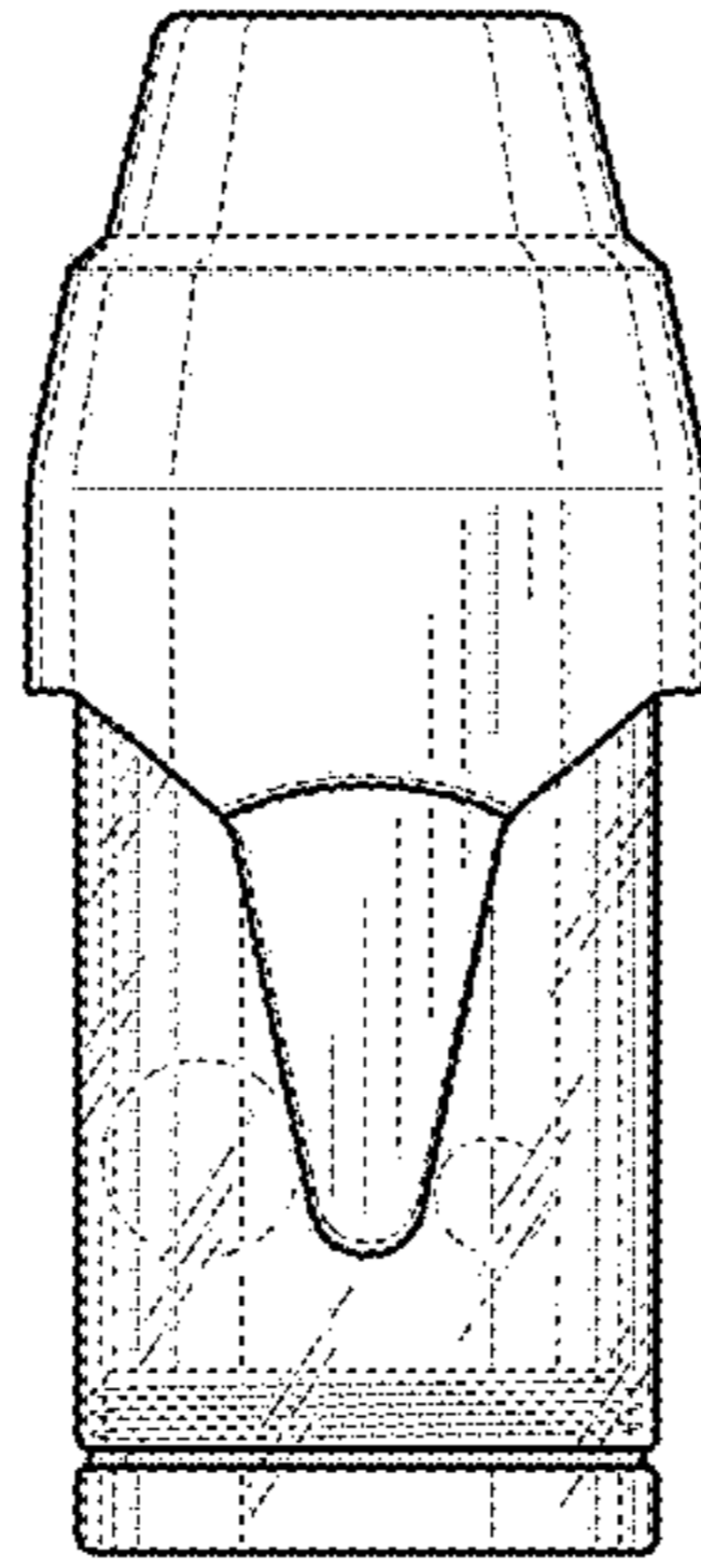

FIG. 25

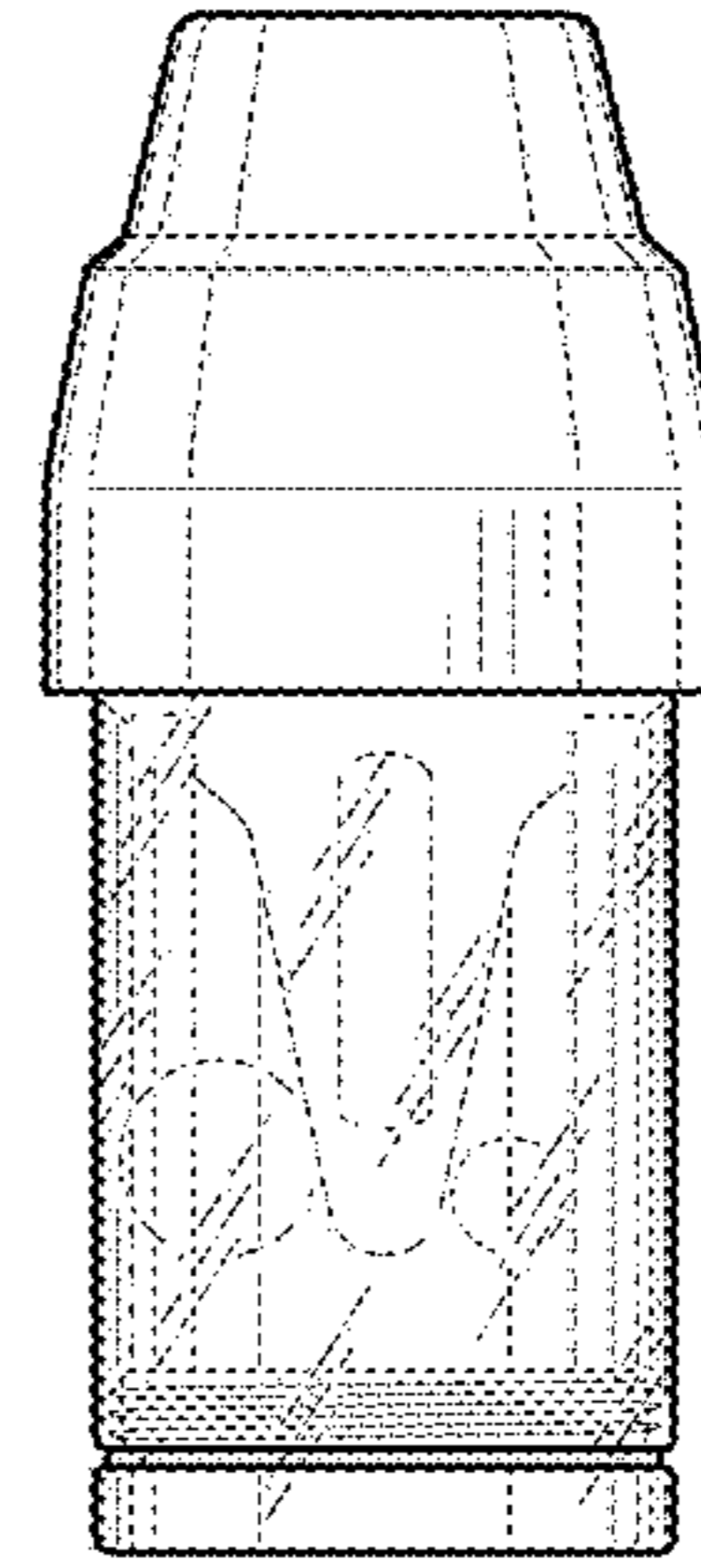

FIG. 26

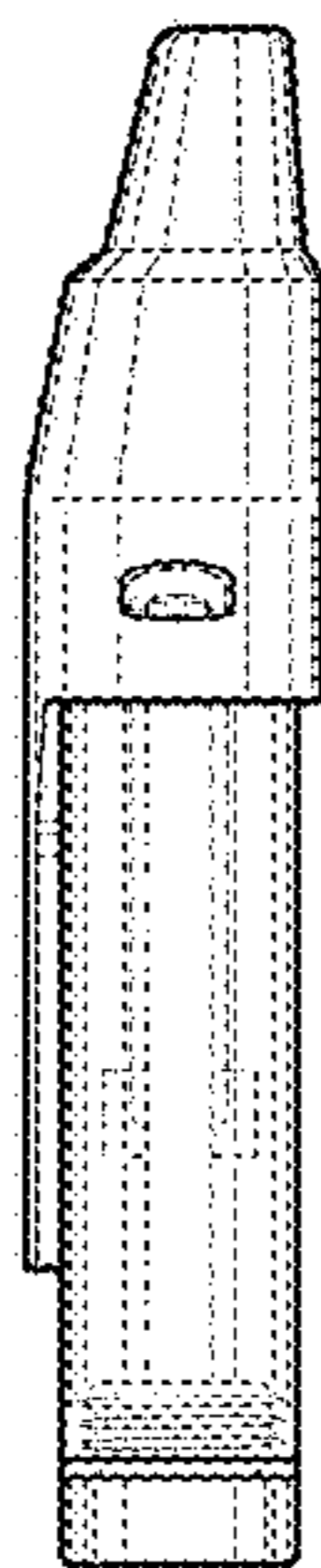

FIG. 27



FIG. 28

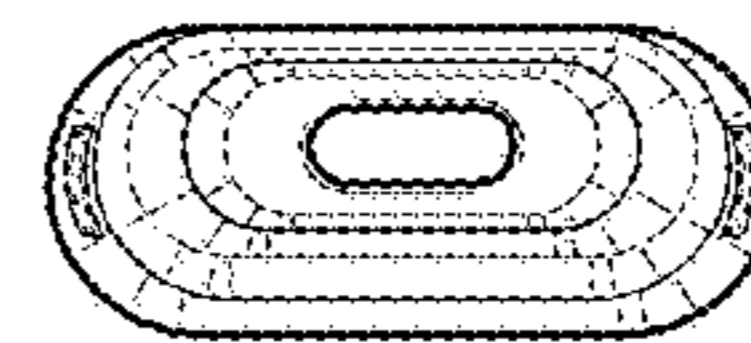

FIG. 29



FIG. 30