



US00D860465S

(12) **United States Design Patent** (10) **Patent No.:** **US D860,465 S**
Lovell et al. (45) **Date of Patent:** **** Sep. 17, 2019**

(54) **ELECTRODE ARRAY**
(71) Applicant: **BLINK DEVICE LLC**, Seattle, WA (US)
(72) Inventors: **Matthew Lovell**, Seattle, WA (US); **Justin Hulvershorn**, Seattle, WA (US); **Karl Schmidt**, Seattle, WA (US)
(73) Assignee: **Blink Device, LLC**, Okemos, MI (US)

D718,458 S * 11/2014 Vosch D24/187
D719,660 S * 12/2014 Vosch D24/187
D728,801 S * 5/2015 Machon D24/187
(Continued)

(**) Term: **15 Years**

FOREIGN PATENT DOCUMENTS

EM 005236148-0001 * 4/2018
KR 30-0854469 5/2016
(Continued)

(21) Appl. No.: **29/624,470**

English Translation of Japanese Notification, related to Japanese Design Application No. 2018-009384, dated Sep. 4, 2018, 2 pgs.
(Continued)

(22) Filed: **Nov. 1, 2017**

(51) **LOC (12) Cl.** **24-02**
(52) **U.S. Cl.**
USPC **D24/187**

OTHER PUBLICATIONS

Primary Examiner — Susan Bennett Hattan
Assistant Examiner — Omeed Agilee
(74) *Attorney, Agent, or Firm* — Bookoff McAndrews, PLLC

(58) **Field of Classification Search**
USPC D24/107, 168, 186, 187, 189, 200
CPC A61B 5/0002; A61B 5/042; A61B 5/0404; A61B 5/0416; A61B 5/0422; A61B 5/0424; A61B 5/0492; A61B 5/04004; A61B 5/0402; A61B 5/04012; A61B 5/04082; A61B 5/04085; A61B 5/04087; A61N 1/046; A61N 1/0472; A61N 1/0476; A61N 1/0492
See application file for complete search history.

(57) **CLAIM**

The ornamental design for an electrode array, as shown and described.

(56) **References Cited**

U.S. PATENT DOCUMENTS

5,131,401 A 7/1992 Westenskow et al.
D443,063 S * 5/2001 Pisani D24/187
6,298,255 B1 10/2001 Cordero et al.
6,456,872 B1 * 9/2002 Faisandier A61B 5/04085 600/390
D501,558 S * 2/2005 Chastain D24/187
D505,206 S * 5/2005 Chastain D24/187
8,506,502 B2 8/2013 Gilhuly
D702,356 S * 4/2014 Vosch D24/187
D702,357 S * 4/2014 Vosch D24/187

DESCRIPTION

FIG. 1 is a top plan view of an electrode array showing our new design;
FIG. 2 is a bottom plan view thereof;
FIG. 3 is a rear elevational view thereof;
FIG. 4 is a front elevational view thereof; and,
FIG. 5 is a top, front, side perspective view thereof.
The broken lines in form of a connection clip in all views and the broken lines in shape of pads in FIG. 2 depict portions of the electrode array that form no part of the claimed design. The claim terminates at the outermost edge of the broken lines and does not include surfaces that may be behind, under, or hidden by the broken lines.

1 Claim, 4 Drawing Sheets

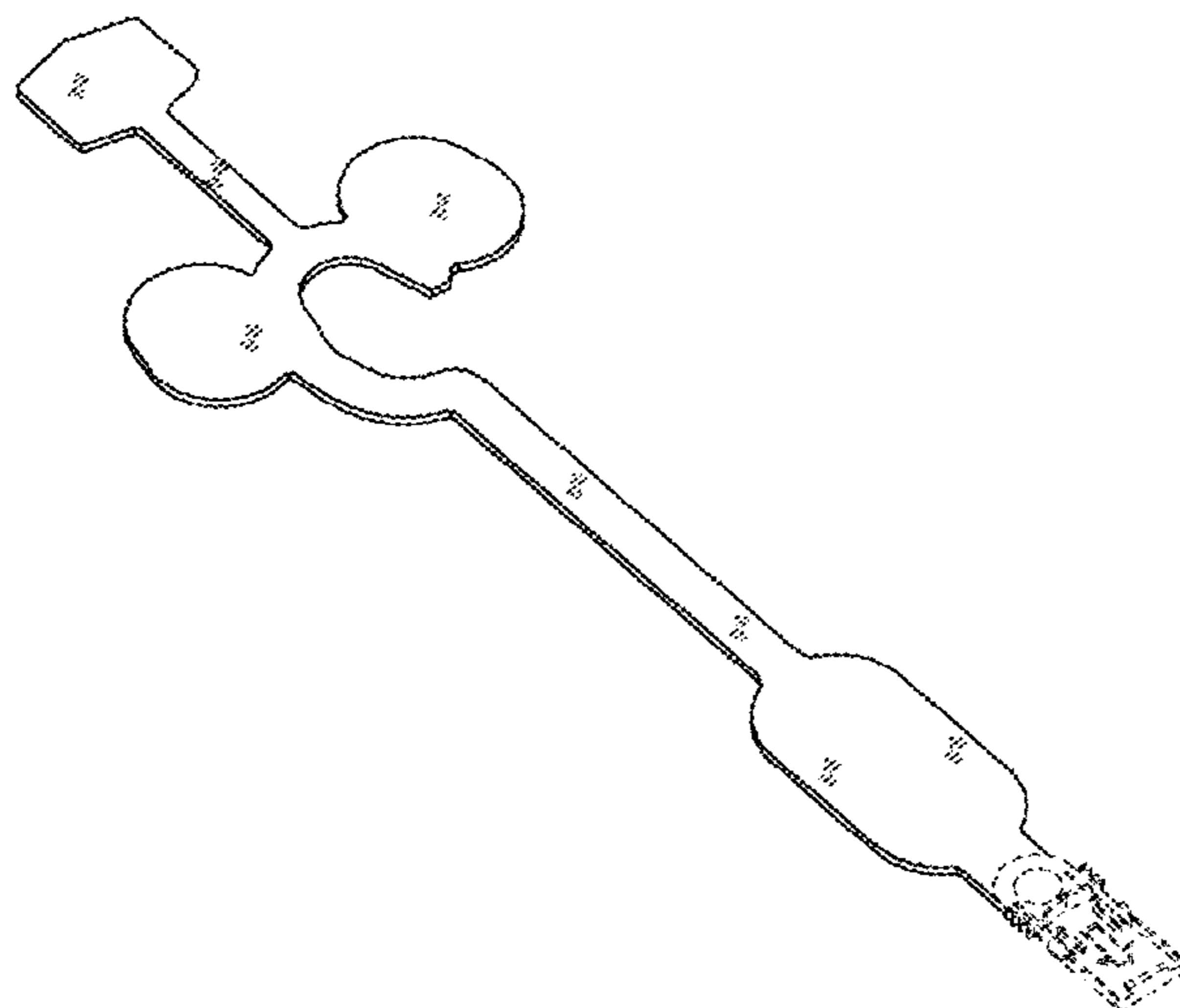

(56)

References Cited

U.S. PATENT DOCUMENTS

D757,952	S	*	5/2016	Wiebenga	D24/200
D761,436	S	*	7/2016	Fogarty	D24/187
D764,672	S	*	8/2016	Vosch	D24/187
D773,672	S	*	12/2016	Machon	D24/187
D790,069	S	*	6/2017	Wong	D24/187
D800,321	S	*	10/2017	Roche	D24/187
D809,663	S	*	2/2018	Nachum	D24/168
D821,587	S	*	6/2018	Vosch	D24/187
D821,588	S	*	6/2018	Vosch	D24/187
2013/0204155	A1		8/2013	Brull et al.		
2014/0012157	A1		1/2014	Gilhuly		
2014/0107524	A1		4/2014	Brull et al.		
2014/0235991	A1		8/2014	Gadsby		

FOREIGN PATENT DOCUMENTS

KR	30-0904466	4/2017
KR	30-0910972	6/2017

OTHER PUBLICATIONS

Japanese Notification, related to Japanese Design Application No.
2018-009384, dated Sep. 4, 2018, 2 pgs.

* cited by examiner

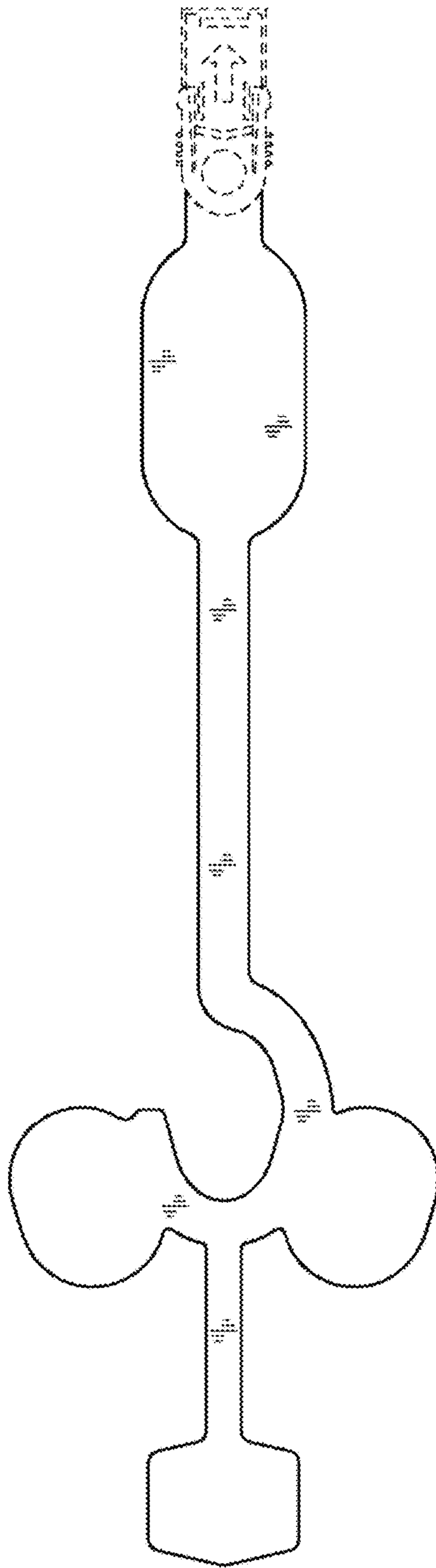

FIG. 1

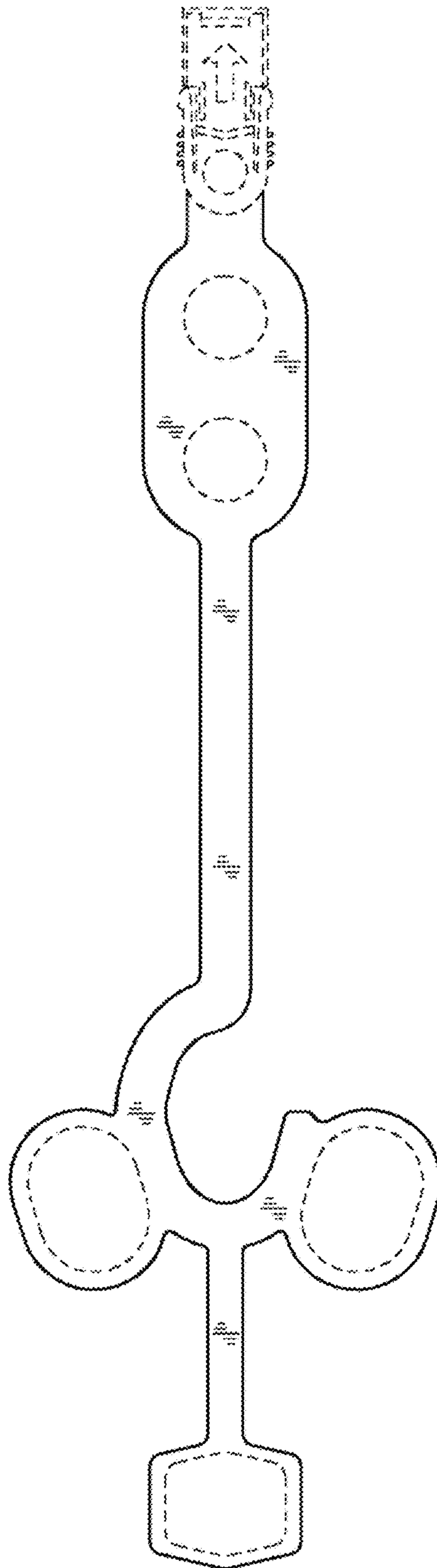

FIG. 2

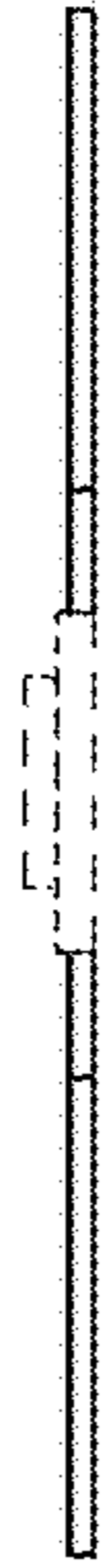

FIG. 3



FIG. 4

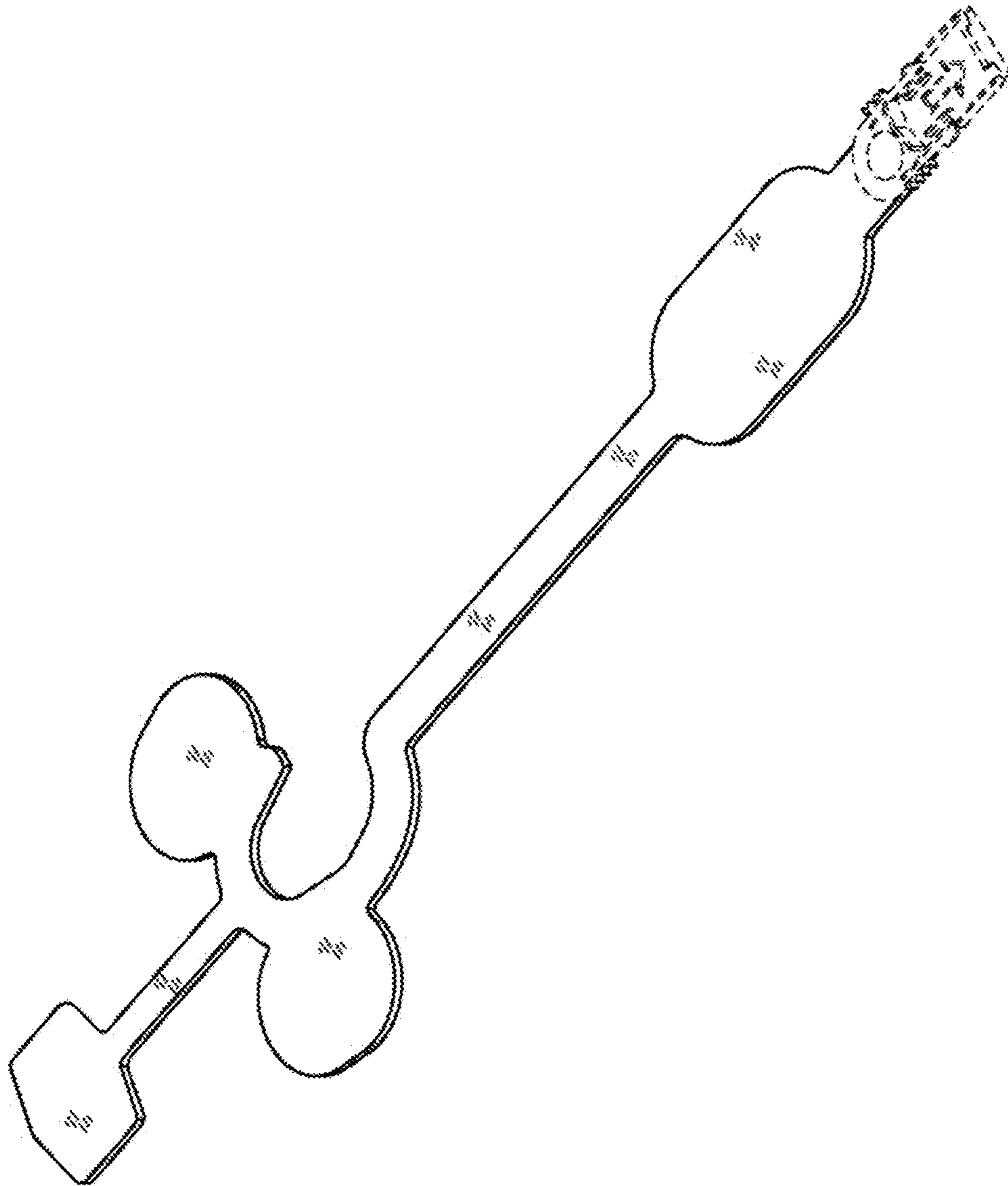

FIG. 5