

US00D860278S

(12) **United States Design Patent** (10) **Patent No.:** **US D860,278 S**
Knudsen (45) **Date of Patent:** **** Sep. 17, 2019**

(54) **LINEAR ACTUATOR AND CONTROL BOX COMBINATION**

(71) Applicant: **LINAK A/S**, Nordborg (DK)
(72) Inventor: **Martin Kahr Knudsen**, Sydals (DK)
(73) Assignee: **LINAK A/S**, Nordborg (DK)
(**) Term: **15 Years**
(21) Appl. No.: **29/630,518**

(22) Filed: **Dec. 21, 2017**

(30) **Foreign Application Priority Data**

Jun. 28, 2017 (DK) DA 2017 00055
Jun. 28, 2017 (DK) DA 2017 00056
Jun. 28, 2017 (DK) DA 2017 00057
Jun. 28, 2017 (DK) DA 2017 00059

(51) **LOC (12) Cl.** **15-09**

(52) **U.S. Cl.**
USPC **D15/148**

(58) **Field of Classification Search**
USPC D12/345; D13/118, 158, 162, 184;
D15/1-5, 7, 9, 143, 148, 149, 199
CPC B66F 3/18; F16H 19/04; F16H 19/039;
H01F 7/066
See application file for complete search history.

(56) **References Cited**

U.S. PATENT DOCUMENTS

D400,220 S * 10/1998 Nemoto D15/148
D458,284 S * 6/2002 Landerholm D15/143
D577,753 S * 9/2008 Lund D15/143
D589,459 S * 3/2009 Iida D13/158
D589,991 S * 4/2009 Chen D15/143
D594,487 S * 6/2009 Lund D15/143
D595,752 S * 7/2009 Lin D15/143
D595,753 S * 7/2009 Tseng D15/143
D596,653 S * 7/2009 Fukano D15/143

(Continued)

OTHER PUBLICATIONS

Data Sheet for Linak Actuator LA27 (8 pgs.), retrieved from https://web.archive.org/web/20160730151752/http://www.linak-us.com/corporate/pdf/english/data%20sheet/linear%20actuator_la27_data%20sheet_eng.pdf (Wayback Machine) with date of Jul. 30, 2016.

(Continued)

Primary Examiner — Patricia A Palasik

(74) *Attorney, Agent, or Firm* — Dykema Gossett PLLC

(57) **CLAIM**

The ornamental design for a linear actuator and control box combination, as shown and described.

DESCRIPTION

FIG. 1 is a perspective top view of a linear actuator and control box combination showing a first embodiment of my design,
FIG. 2 is a perspective bottom view thereof,
FIG. 3 is an elevational right side view thereof,
FIG. 4 is an elevational left side view thereof,
FIG. 5 is a top plan view thereof,
FIG. 6 is a bottom plan view thereof,
FIG. 7 is an elevational front view thereof,
FIG. 8 is an elevational rear view thereof,
FIG. 9 is a perspective top view of a second embodiment thereof,
FIG. 10 is a perspective bottom view thereof,
FIG. 11 is an elevational right side view thereof,
FIG. 12 is an elevational left side view thereof,
FIG. 13 is a top plan view thereof,
FIG. 14 is a bottom plan view thereof,
FIG. 15 is an elevational front view thereof; and,
FIG. 16 is an elevational rear view thereof.
The broken away symbols in the drawings indicate that any portion of the article beyond what is shown forms no part of the claimed design.

1 Claim, 16 Drawing Sheets

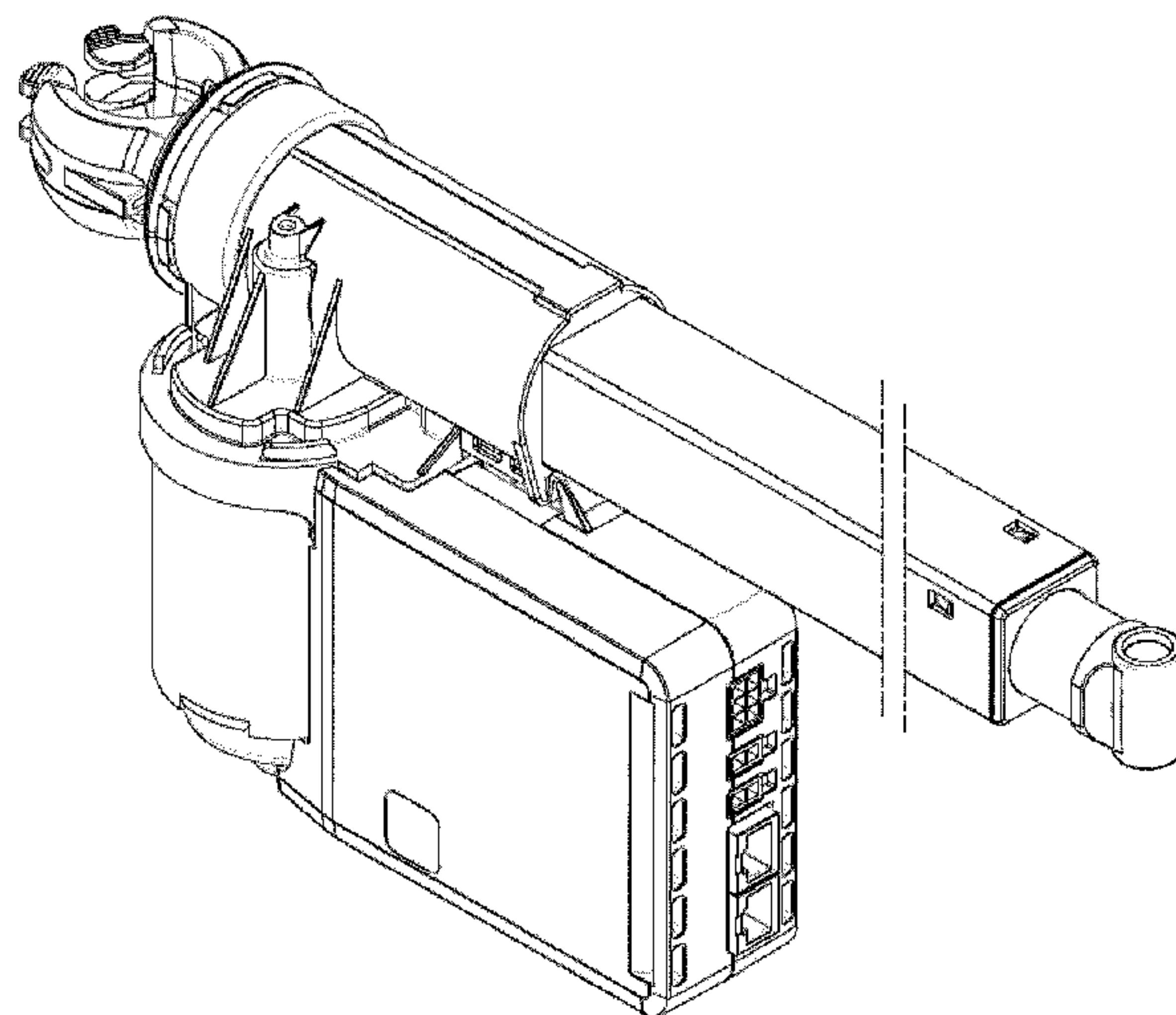

(56)

References Cited

U.S. PATENT DOCUMENTS

D620,961	S *	8/2010	Iversen	D15/143
D625,745	S *	10/2010	Chiang	D15/143
D646,310	S *	10/2011	Lan	D15/143
D654,524	S *	2/2012	Iversen	D15/199
D656,975	S *	4/2012	Tseng	D15/143
D727,714	S *	4/2015	Gherlenda	D8/331
D765,748	S *	9/2016	Bogelund	D15/143
D765,749	S *	9/2016	Wu	D15/143
D776,728	S *	1/2017	Wu	D15/143
D776,729	S *	1/2017	Wu	D15/143
D785,061	S *	4/2017	Gong	D15/148
D785,062	S *	4/2017	Gong	D15/148
D792,490	S *	7/2017	Lin	D15/143
D792,491	S *	7/2017	Lin	D15/143
D792,492	S *	7/2017	Lin	D15/143
D800,195	S *	10/2017	Lin	D15/148
D806,151	S *	12/2017	Landerholm	D15/143
D806,153	S *	12/2017	Skov	D15/148
D819,100	S *	5/2018	Lin	D15/148
2004/0093969	A1 *	5/2004	Nielsen	A47C 20/041 74/89.23
2005/0160846	A1 *	7/2005	Chiang	F16H 25/20 74/89.35
2009/0151489	A1 *	6/2009	Jensen	F16H 25/20 74/89.33
2010/0186529	A1 *	7/2010	Chiang	F16H 25/2015 74/89.37
2011/0068725	A1 *	3/2011	Bastholm	F16H 25/2015 318/468

OTHER PUBLICATIONS

Data Sheet for Linak Actuator LA31 Careline (8 pgs.), retrieved from <https://web.archive.org/web/20160729200552/http://www.linak->

[us.com/corporate/pdf/english/data%20sheet/linear%20actuator_la31c_data%20sheet_eng.pdf](https://web.archive.org/web/20160915173206/http://www.linak.com/corporate/pdf/english/data%20sheet/linear%20actuator_la31c_data%20sheet_eng.pdf) (Wayback Machine) with date of Jul. 29, 2016.

Data Sheet for Linak Actuator LA31 Deskline (4 pgs.), retrieved from https://web.archive.org/web/20160915173206/http://www.linak.com/corporate/pdf/english/data%20sheet/linear%20actuator_la31d_data%20sheet_eng.pdf (Wayback Machine) with date of Sep. 15, 2016.

Data Sheet for Linak Actuator LA31 Homeline (8 pgs.), retrieved from https://web.archive.org/web/20160915173226/http://www.linak.com/corporate/pdf/english/data%20sheet/linear%20actuator_la31h_data%20sheet_eng.pdf (Wayback Machine) with date of Sep. 15, 2016.

Data Sheet for TiMotion—TA9 series (11 pgs.), retrieved from <https://web.archive.org/web/20170614055550/http://www.timotion.com/product.php?ProductID=13> (Wayback Machine) with date of Jun. 14, 2017.

Data Sheet for TiMotion—TA26 series (8 pgs.), retrieved from <https://web.archive.org/web/20170614034637/http://www.timotion.com/product.php?ProductID=211> (Wayback Machine) with date of Jun. 14, 2017.

Data Sheet for TiMotion—JP3 series (8 pgs.), retrieved from <https://web.archive.org/web/20170614161605/http://www.timotion.com/product.php?ProductID=43> (Wayback Machine) with date of Jun. 14, 2017.

Data Sheet for Okin—Deltadrive (2 pgs.), retrieved from <https://web.archive.org/web/20150218084847/http://www.okin.de/products/single-drives/products/deltadrive> (Wayback Machine) with date of Feb. 18, 2015.

Martin Kahr Knudsen, Design U.S. Appl. No. 29/630,511, filed Dec. 21, 2017.

* cited by examiner

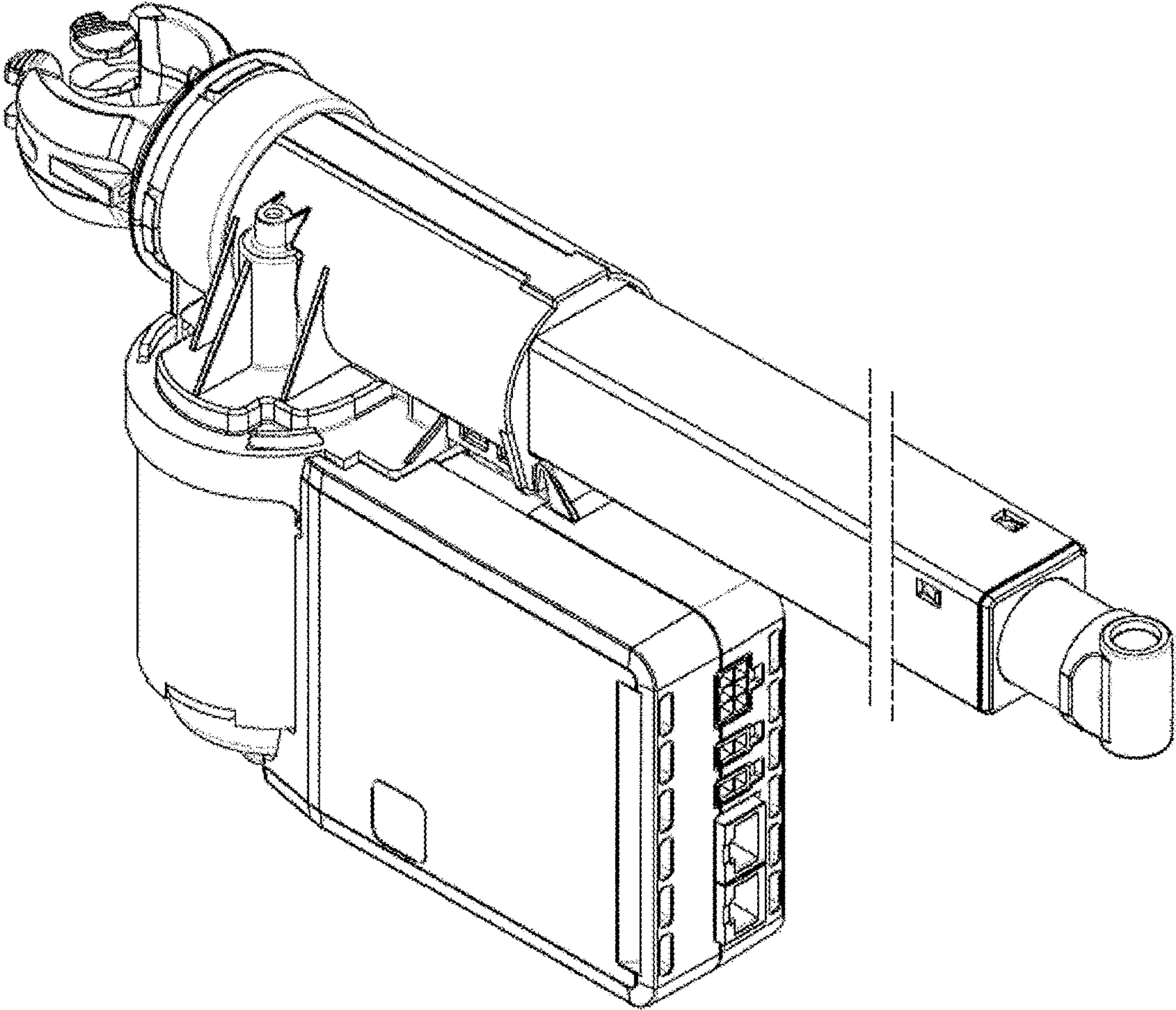

FIG. 1

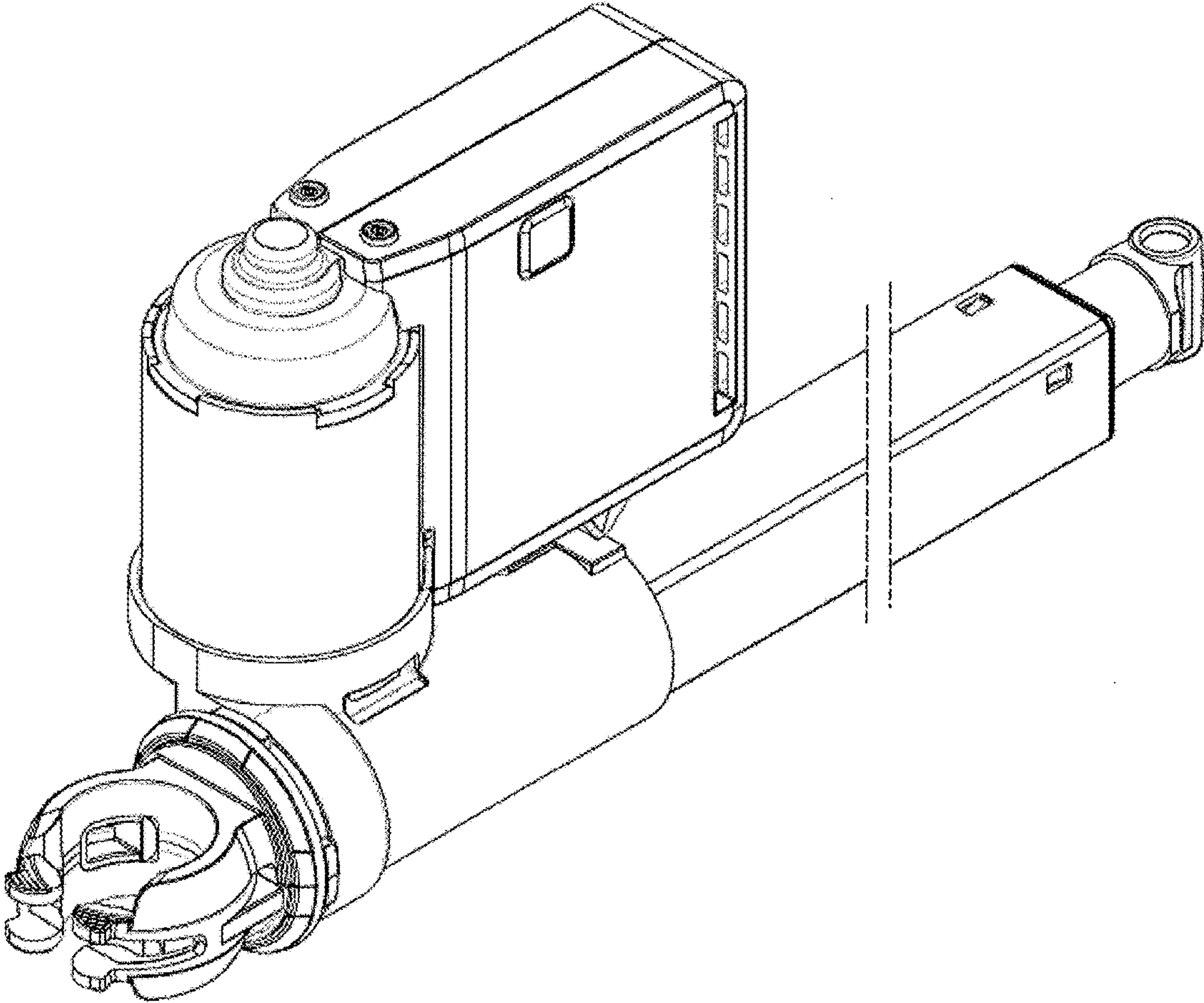

FIG. 2

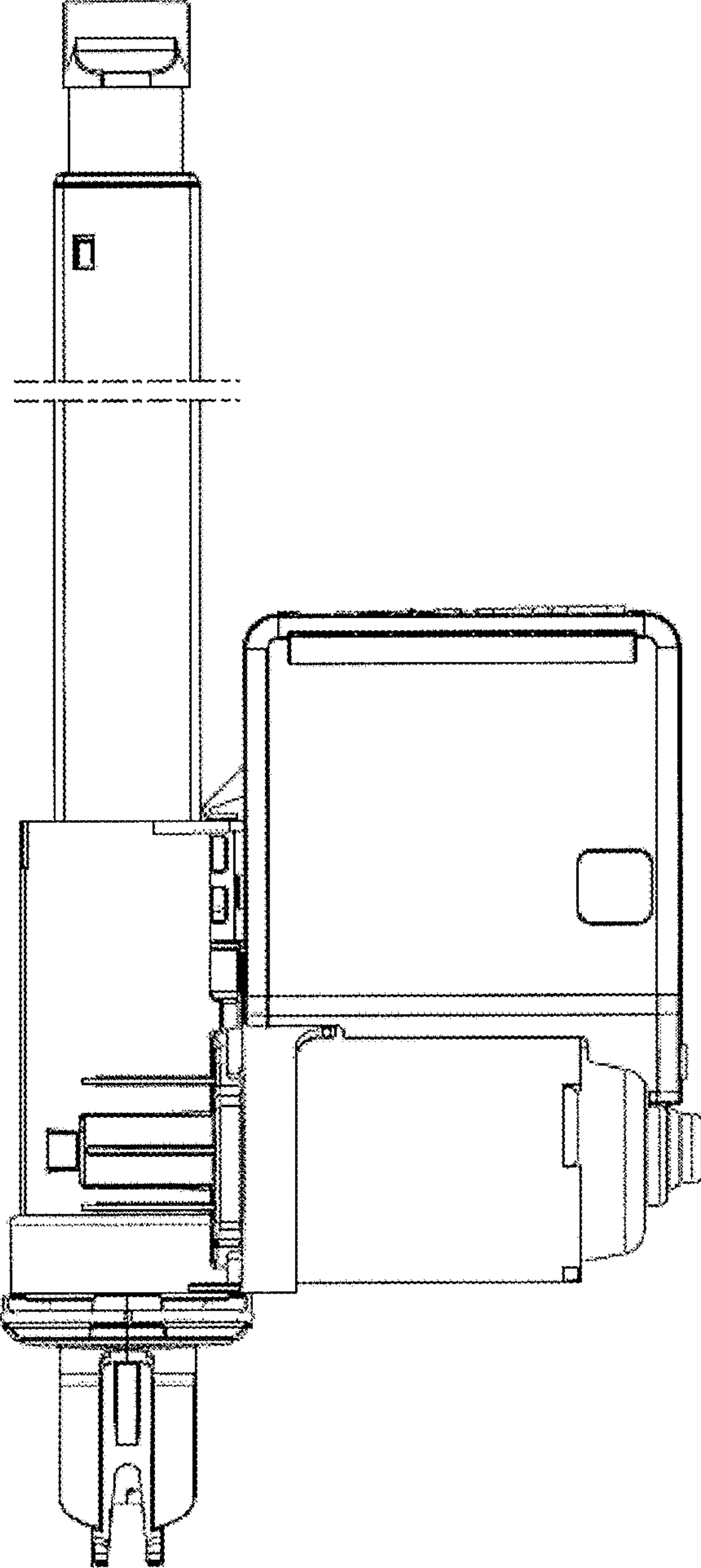

FIG. 3

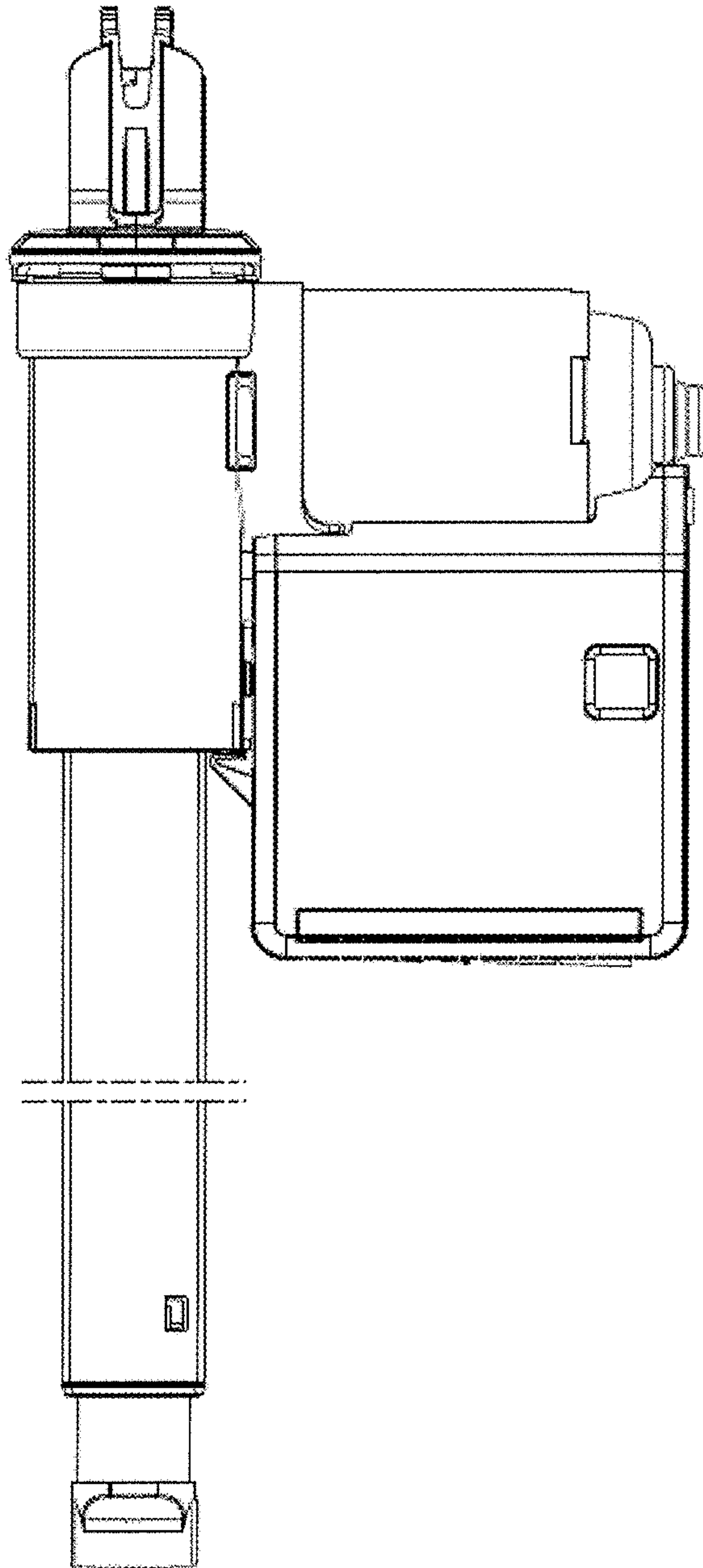

FIG. 4

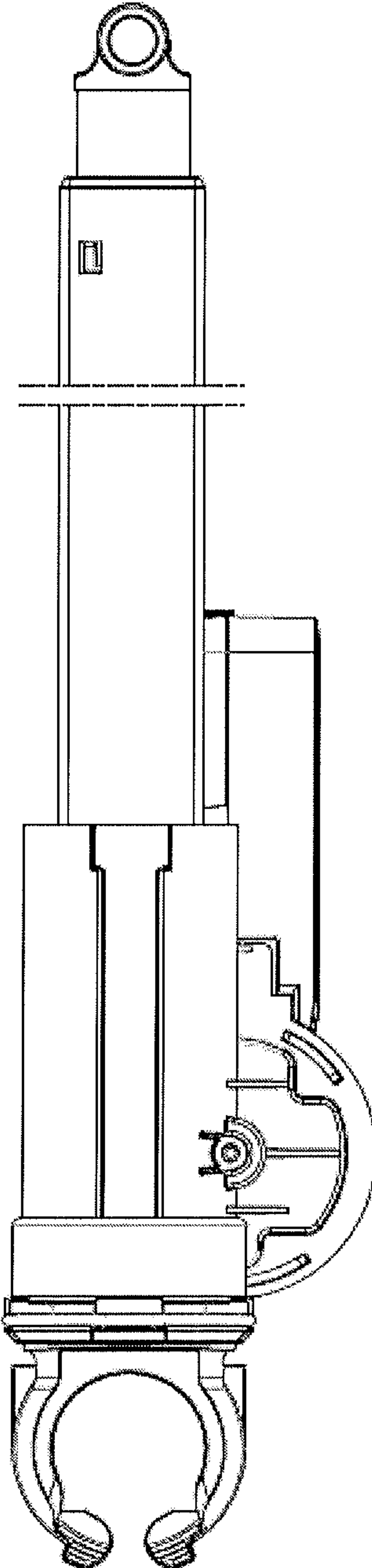

FIG. 5

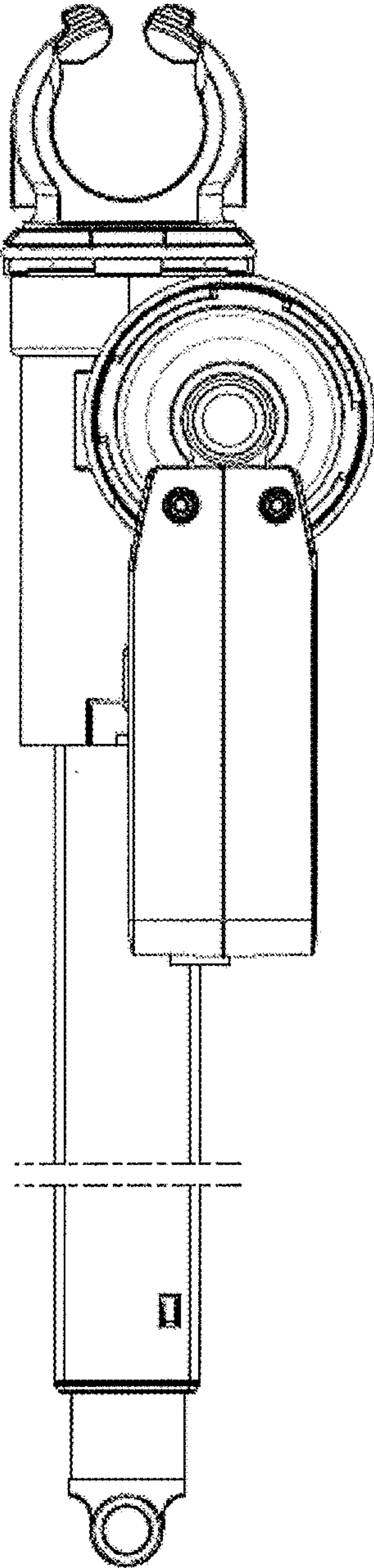

FIG. 6

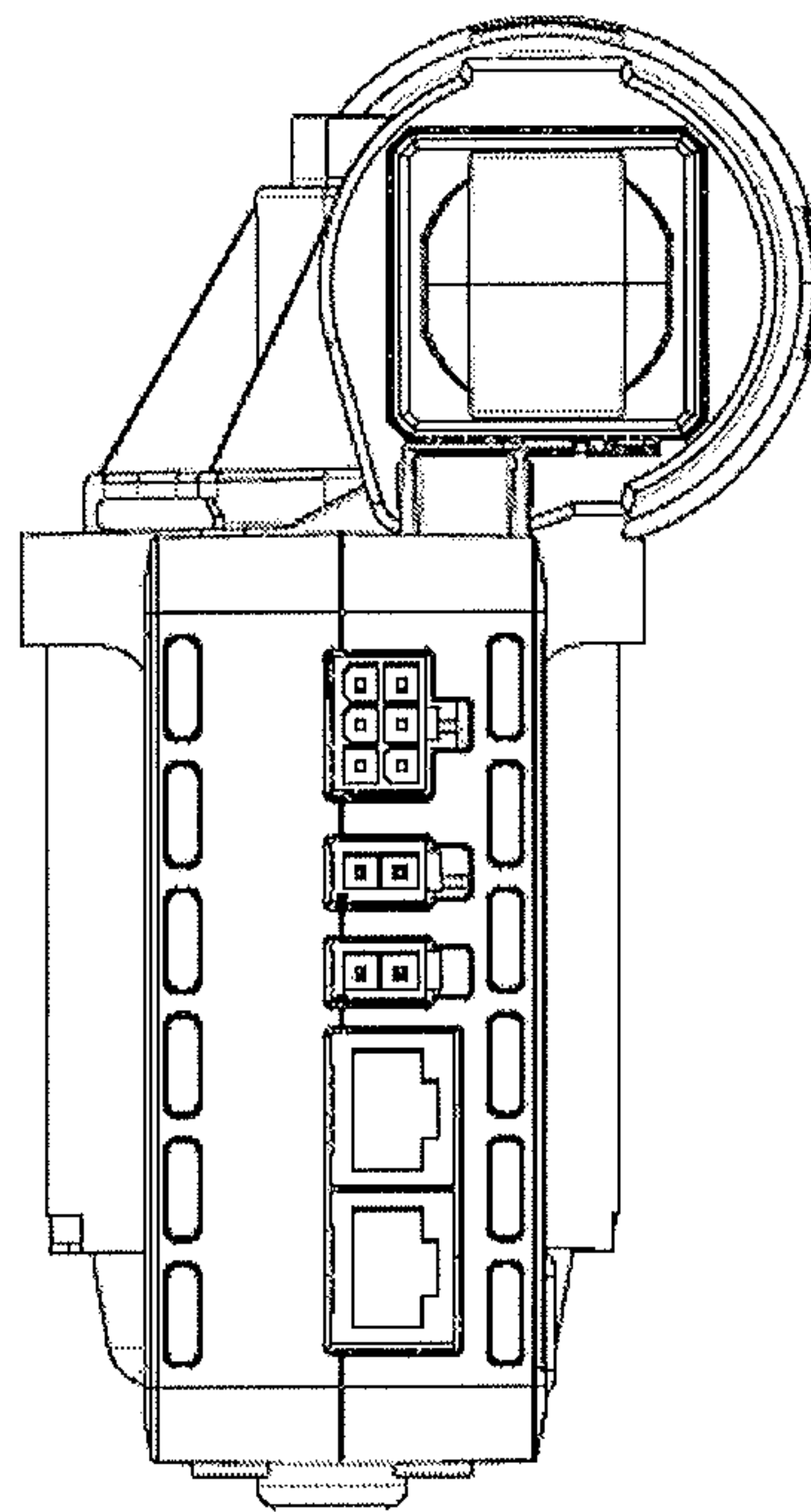

FIG. 7

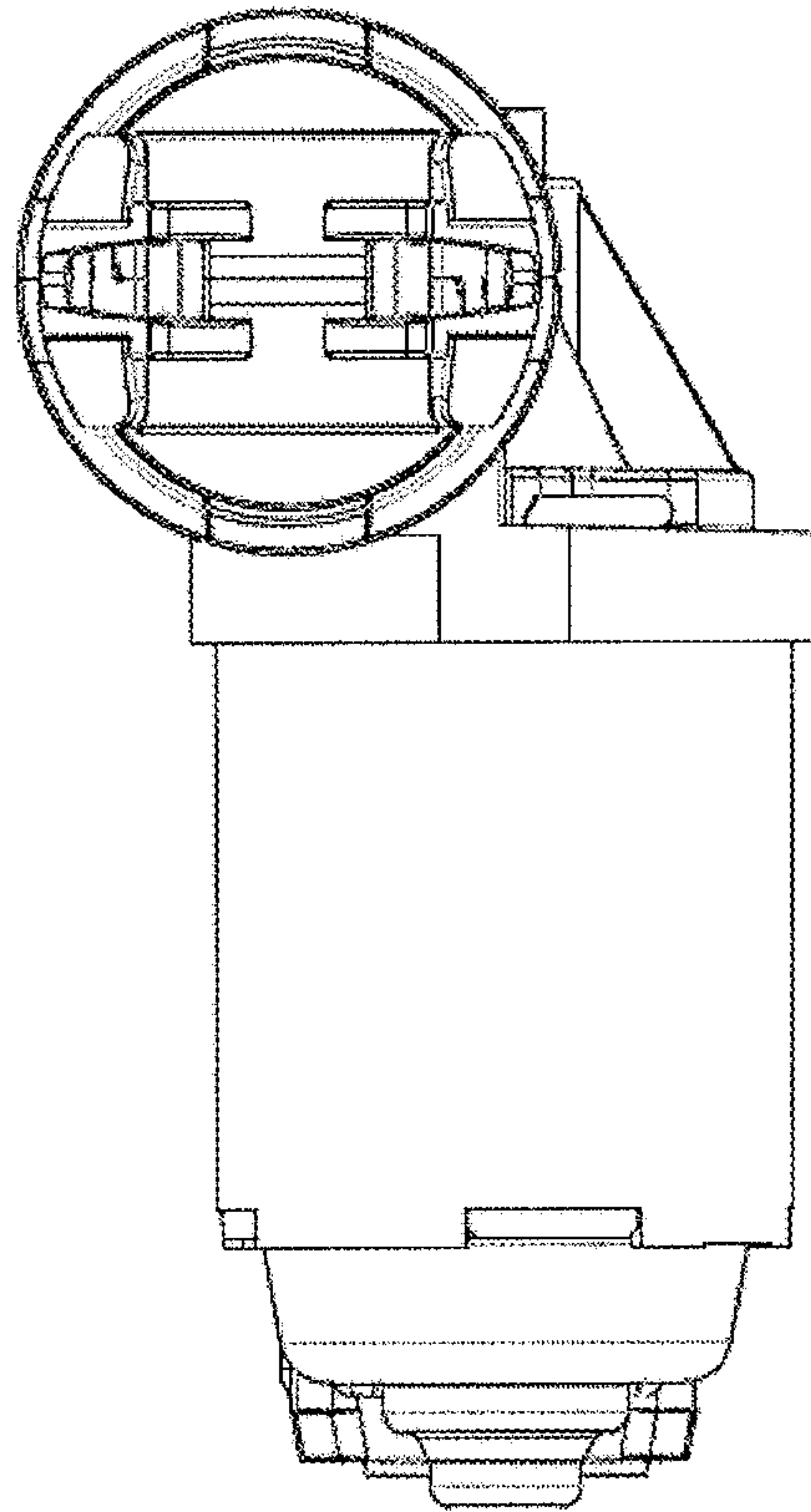

FIG. 8

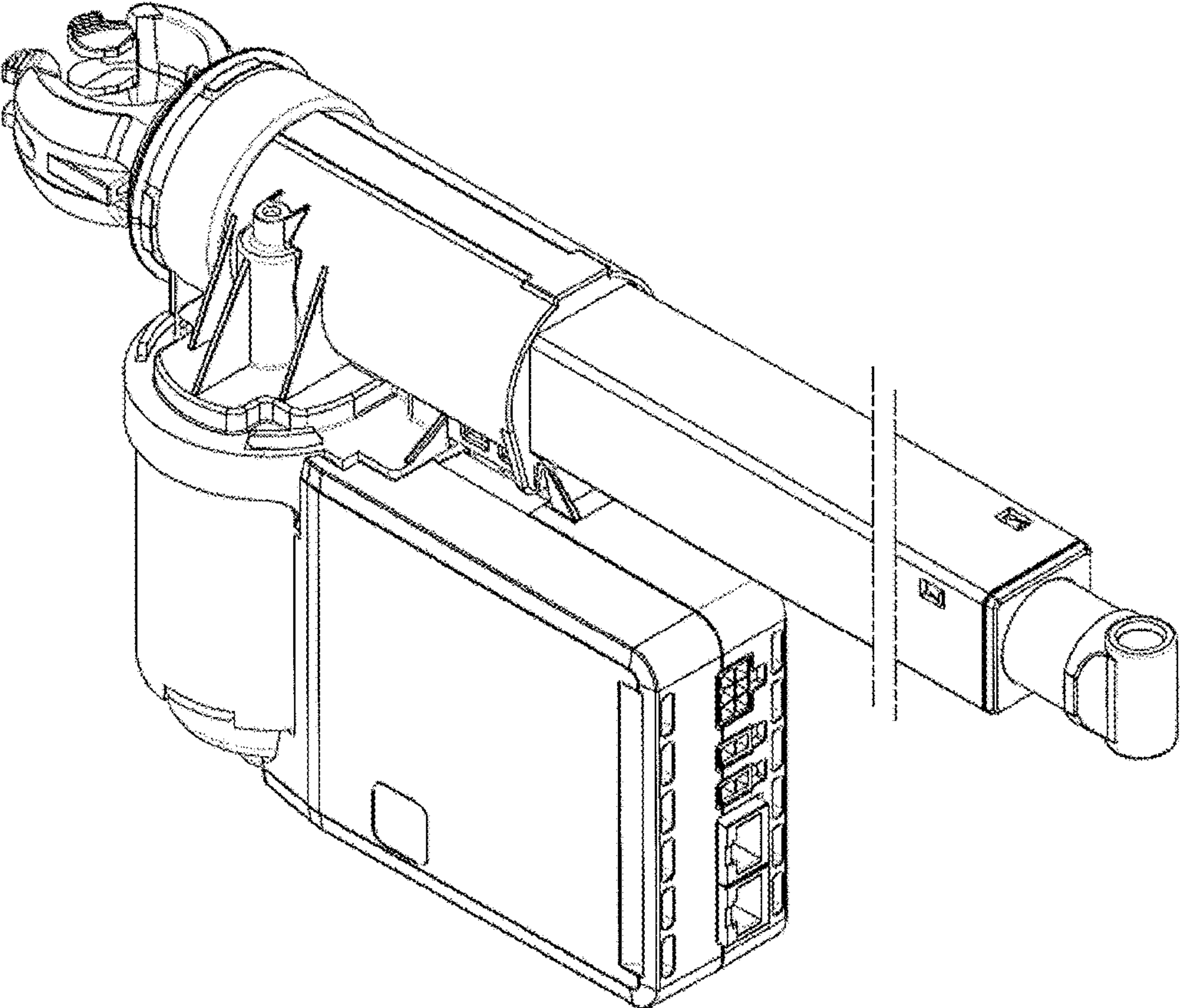

FIG. 9

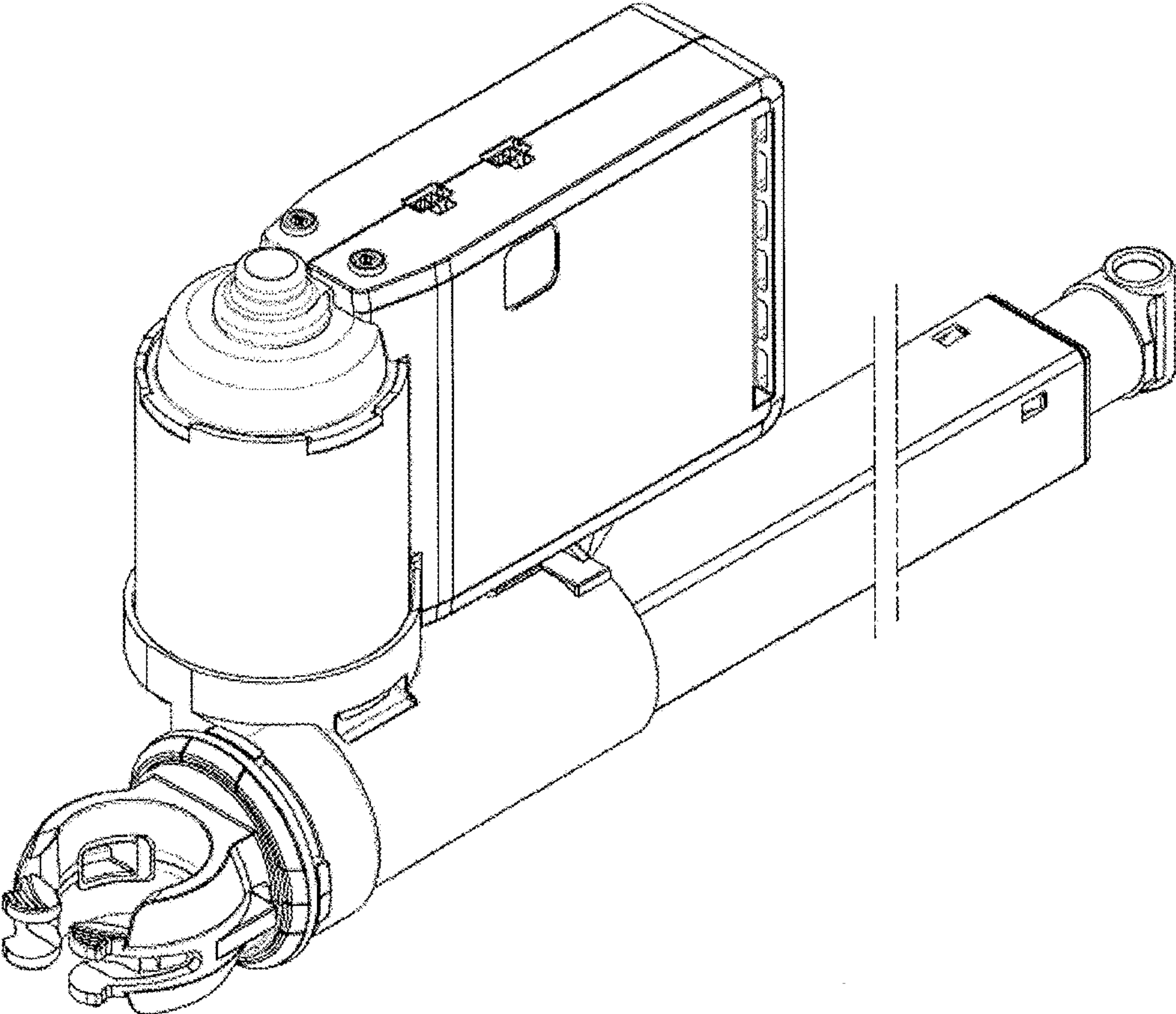

FIG. 10

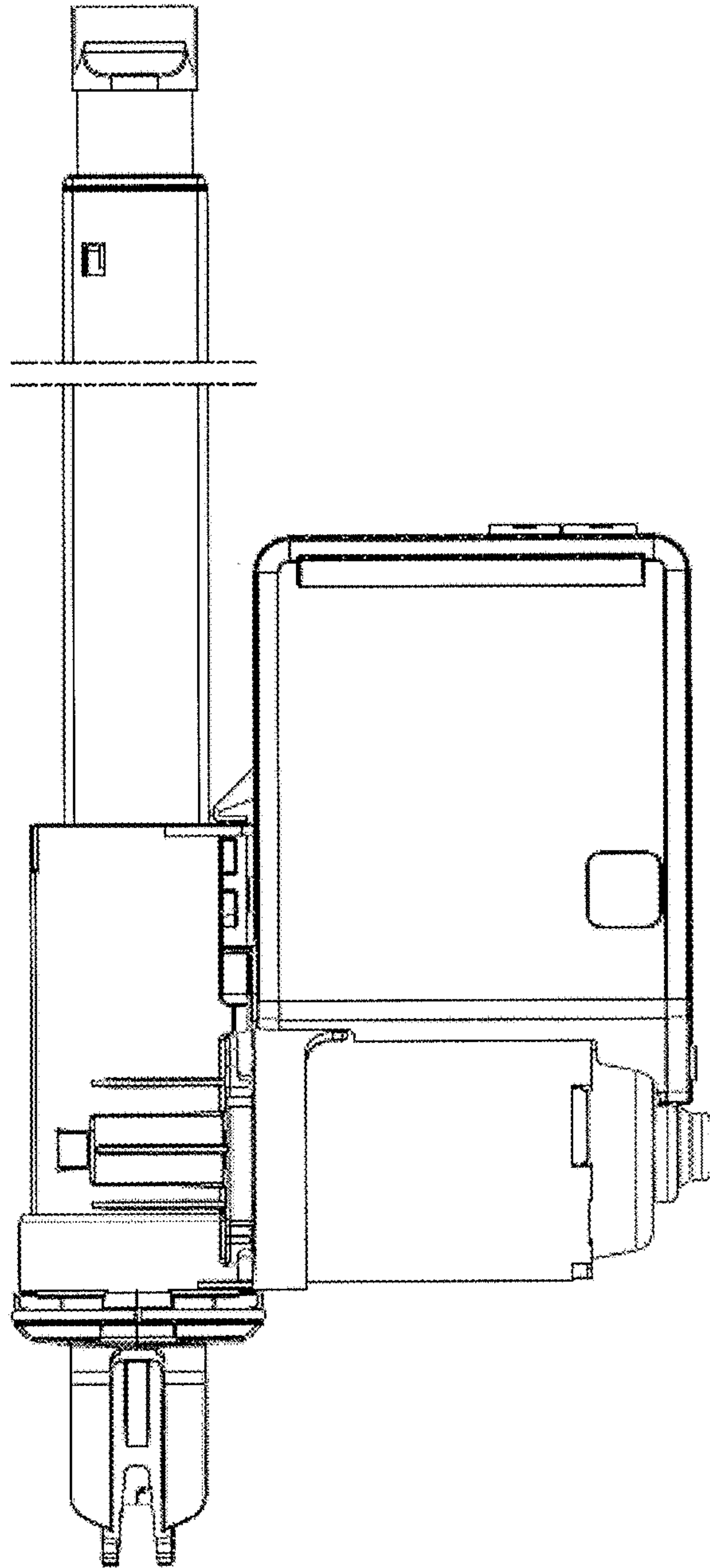

FIG. 11

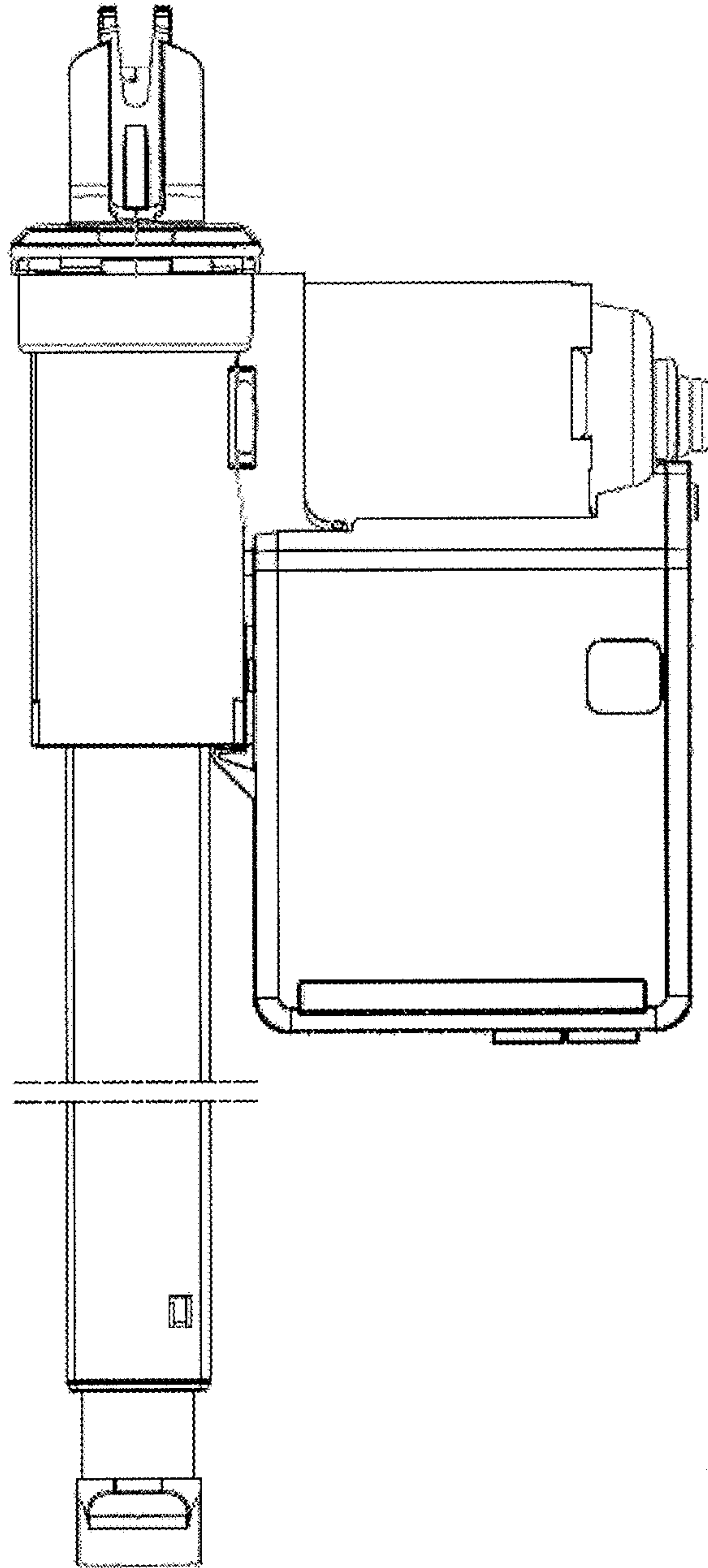

FIG. 12

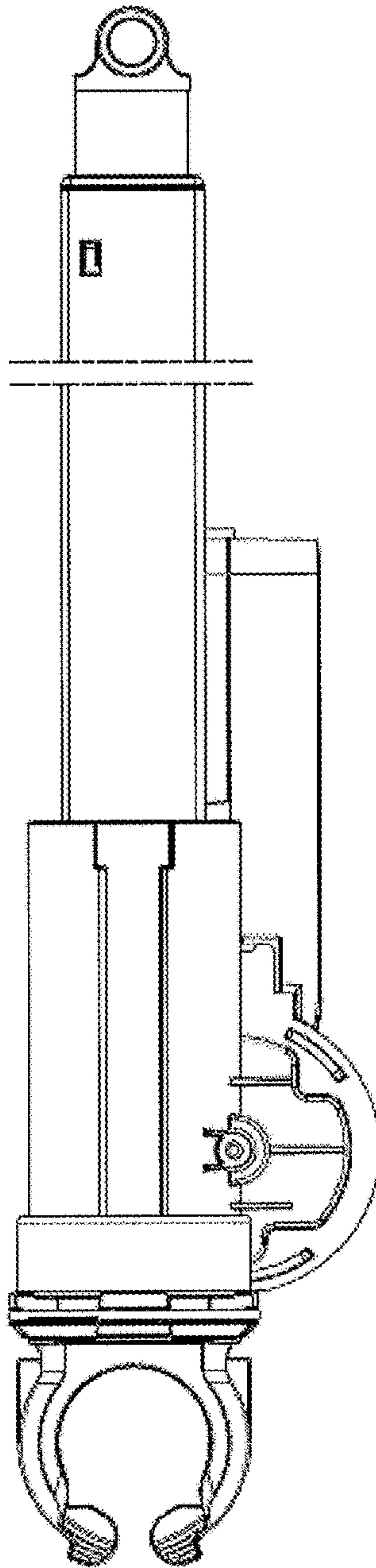

FIG. 13

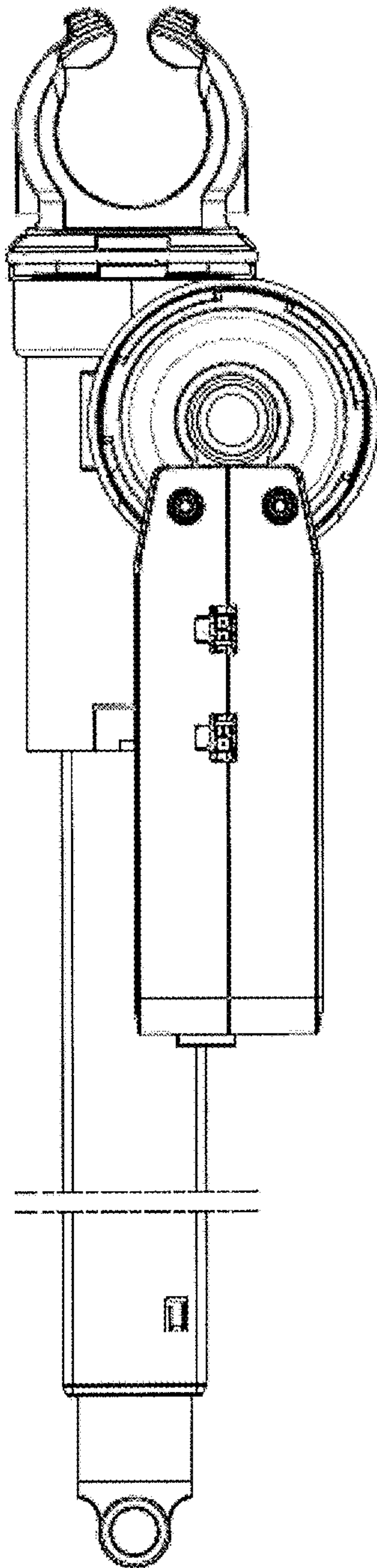

FIG. 14

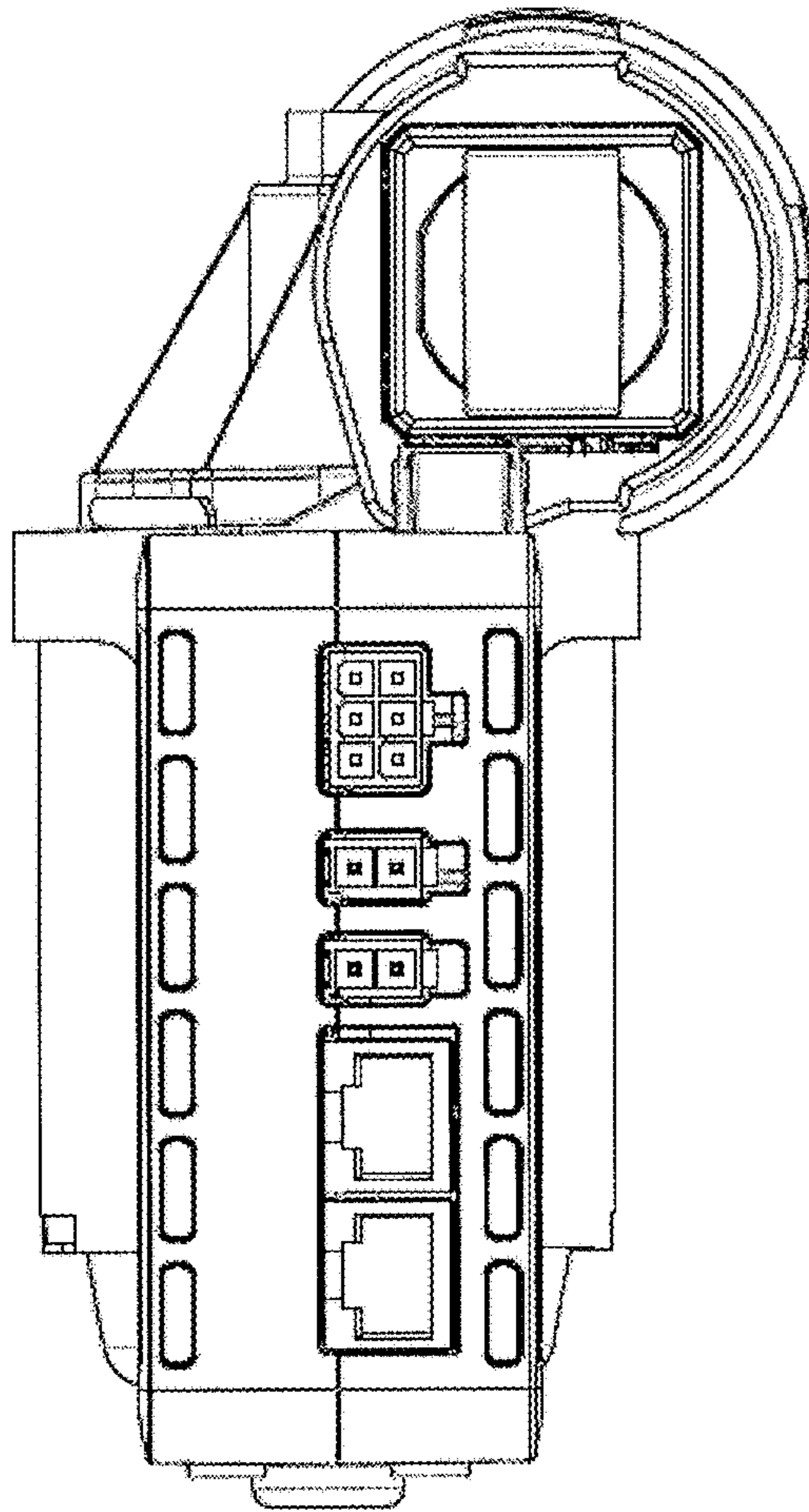

FIG. 15

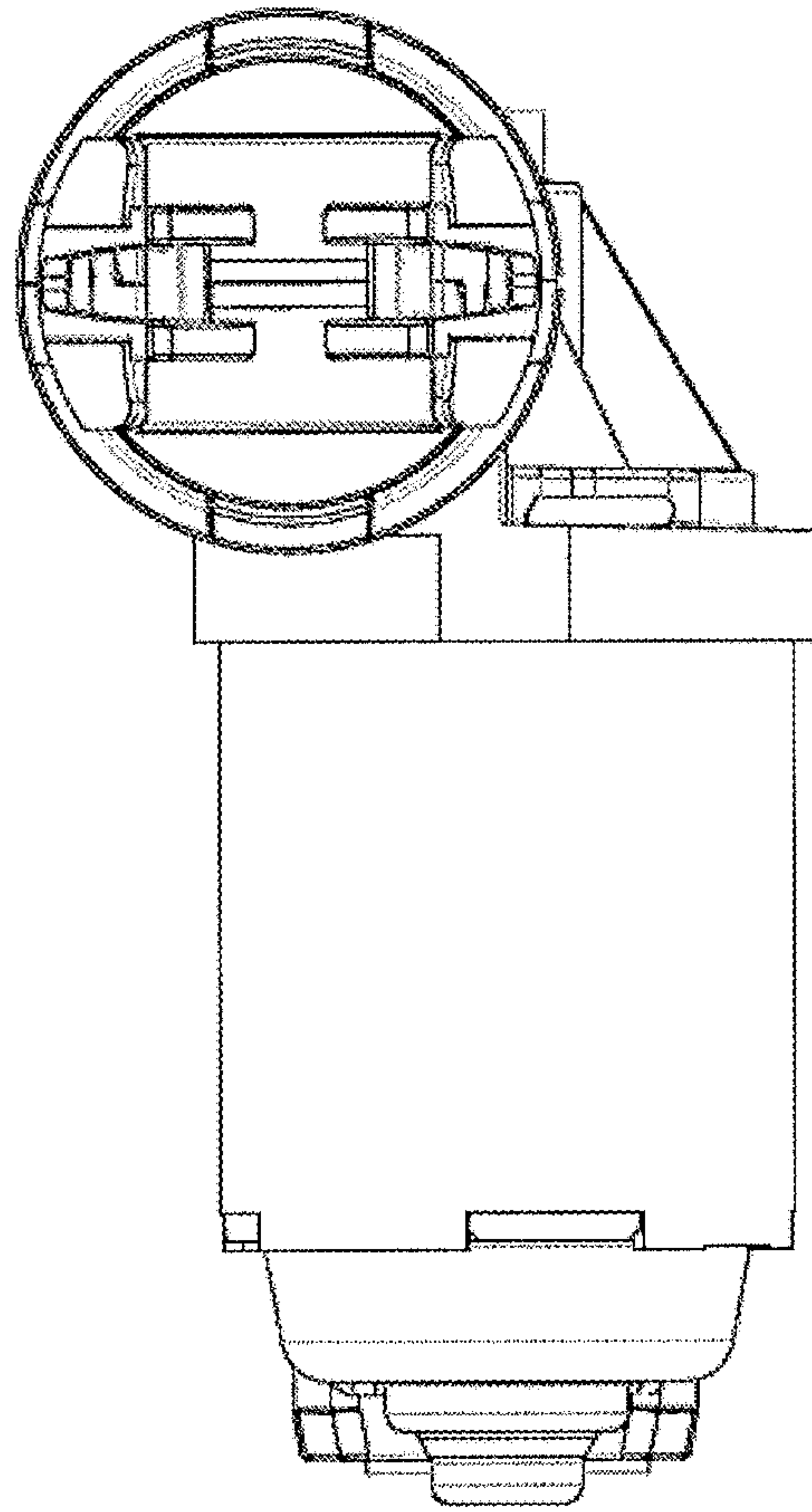

FIG. 16