



US00D860013S

(12) **United States Design Patent** (10) **Patent No.:** **US D860,013 S**
Ahn et al. (45) **Date of Patent:** **** Sep. 17, 2019**

- (54) **REAR SENSOR HOUSING**
- (71) Applicant: **Waymo LLC**, Mountain View, CA (US)
- (72) Inventors: **YooJung Ahn**, Mountain View, CA (US); **Joshua Newby**, San Francisco, CA (US); **Albert Shane**, Berkeley, CA (US)
- (73) Assignee: **Waymo LLC**, Mountain View, CA (US)
- (**) Term: **15 Years**
- (21) Appl. No.: **29/656,372**
- (22) Filed: **Jul. 12, 2018**

Related U.S. Application Data

- (62) Division of application No. 29/602,112, filed on Apr. 28, 2017, now Pat. No. Des. 834,971.
- (51) **LOC (12) Cl.** **10-04**
- (52) **U.S. Cl.**
USPC **D10/70**; D12/190; D12/197
- (58) **Field of Classification Search**
USPC D10/70; D12/190, 197
CPC .. B60Q 1/0017; B60Q 1/0023; B60Q 1/0029;
B60Q 1/0035; B60Q 1/0041; B60Q 1/26;
B60Q 1/2603; B60Q 1/2607; B60Q
1/2611; B60Q 9/002; B60Q 9/003; B60Q
9/004; B60Q 9/006; B60Q 9/007; B60Q
9/008; B60R 1/10; B60R 1/12; B60R
2001/1284
See application file for complete search history.

(56) **References Cited**

U.S. PATENT DOCUMENTS

- D328,436 S * 8/1992 Fuerst D10/46
- 5,945,907 A 8/1999 Yaron et al.
- D478,518 S * 8/2003 Porter D10/70

- D525,888 S * 8/2006 Porter D10/70
 - 9,725,060 B1 8/2017 Daniel et al.
 - 9,862,311 B2 * 1/2018 Kiriya B60Q 1/0023
 - D826,073 S * 8/2018 Alkelai D10/70
- (Continued)

Primary Examiner — Antoine Duval Davis
(74) *Attorney, Agent, or Firm* — Botos Churchill IP Law

(57) **CLAIM**

The ornamental design for a rear sensor housing, as shown and described.

DESCRIPTION

The present application is related to application Ser. No. 29/602,101, entitled Roof Sensor Housing, to application Ser. No. 29/602,117, entitled Fender Sensor Housing, and to application Ser. No. 29/602,110, entitled Rear Sensor Housing, each of which was filed on Apr. 28, 2017, the entire disclosures of which are incorporated by reference herein. FIG. 1 is a front perspective view of a rear sensor housing according to our design; FIG. 2 is a front elevation view thereof; FIG. 3 is a back elevation view thereof; FIG. 4 is a right side elevation view thereof; FIG. 5 is a left side elevation view thereof; FIG. 6 is a top plan view thereof; FIG. 7 is a bottom plan view thereof; FIG. 8 is a front perspective view of the rear sensor housing positioned on a first exemplary vehicle; and, FIG. 9 is a front perspective view of the rear sensor housing positioned on a second exemplary vehicle. The broken lines shown in FIGS. 1-7 illustrate portions of the rear sensor housing that form no part of the claimed design. The broken lines shown in FIGS. 8-9 illustrate portions of the rear sensor housing and the exemplary vehicles that form no part of the claimed design. The specific placement of the rear sensor housing in FIGS. 8-9 on the exemplary vehicles are for illustrative purposes only.

1 Claim, 6 Drawing Sheets

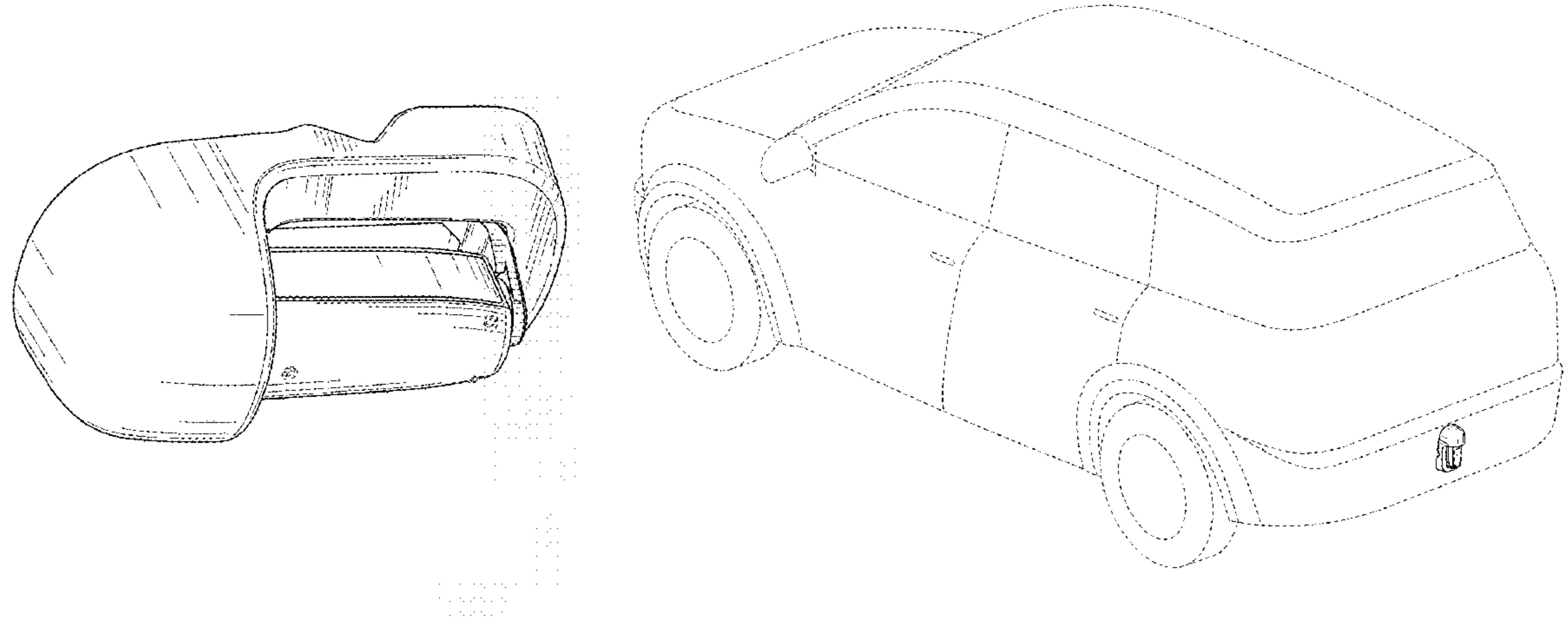

(56)

References Cited

U.S. PATENT DOCUMENTS

2016/0011594 A1 1/2016 Chung et al.
2017/0151933 A1 6/2017 Doorley et al.
2017/0293016 A1 10/2017 McCloskey et al.
2017/0300060 A1 10/2017 Crawley
2017/0343654 A1 11/2017 Valois et al.
2018/0011173 A1 1/2018 Newman
2018/0015886 A1 1/2018 Frank et al.
2018/0017680 A1 1/2018 Pennecot et al.
2018/0037268 A1 2/2018 Moore et al.
2018/0086280 A1 3/2018 Nguyen

* cited by examiner

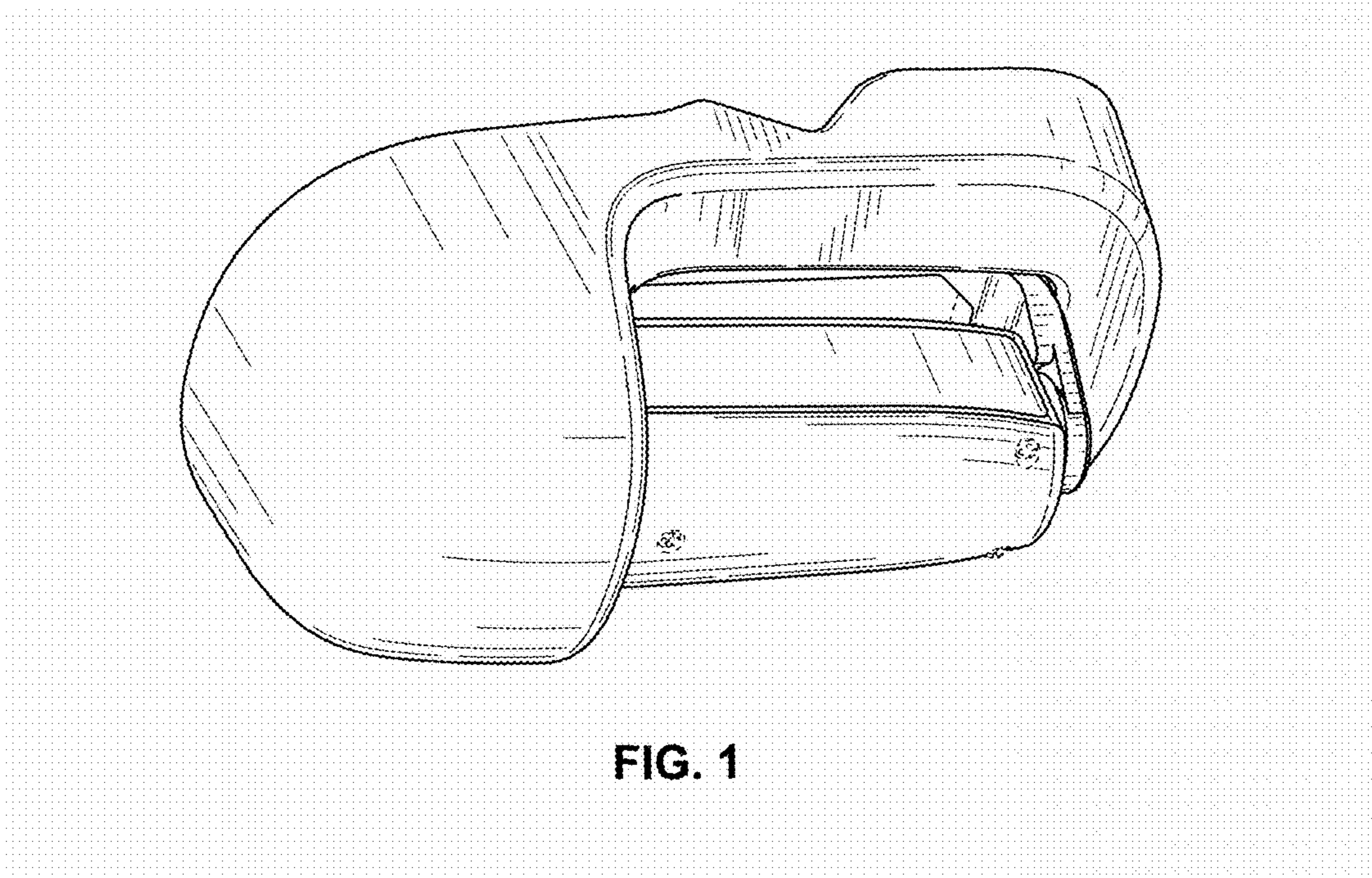

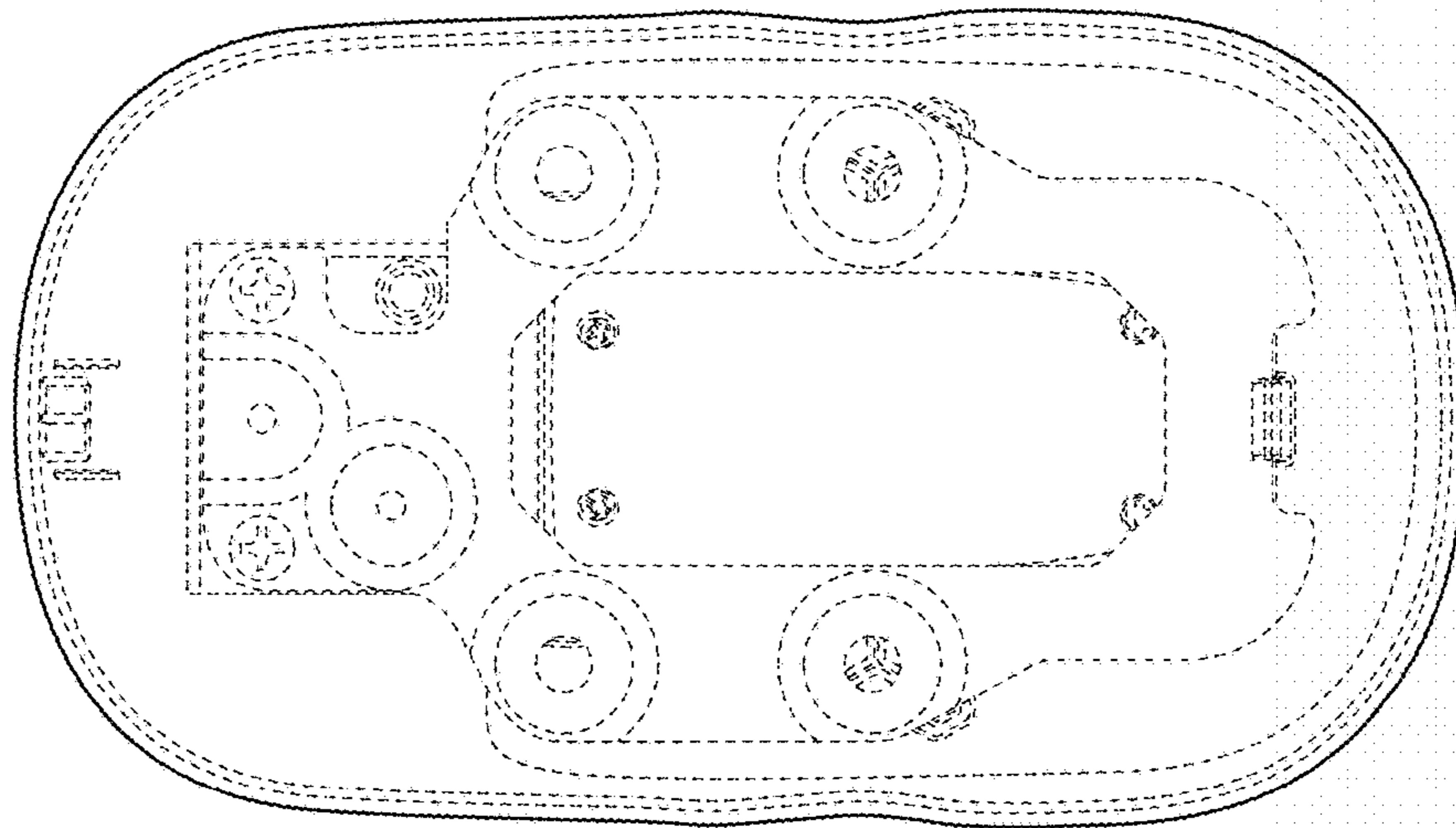

FIG. 3

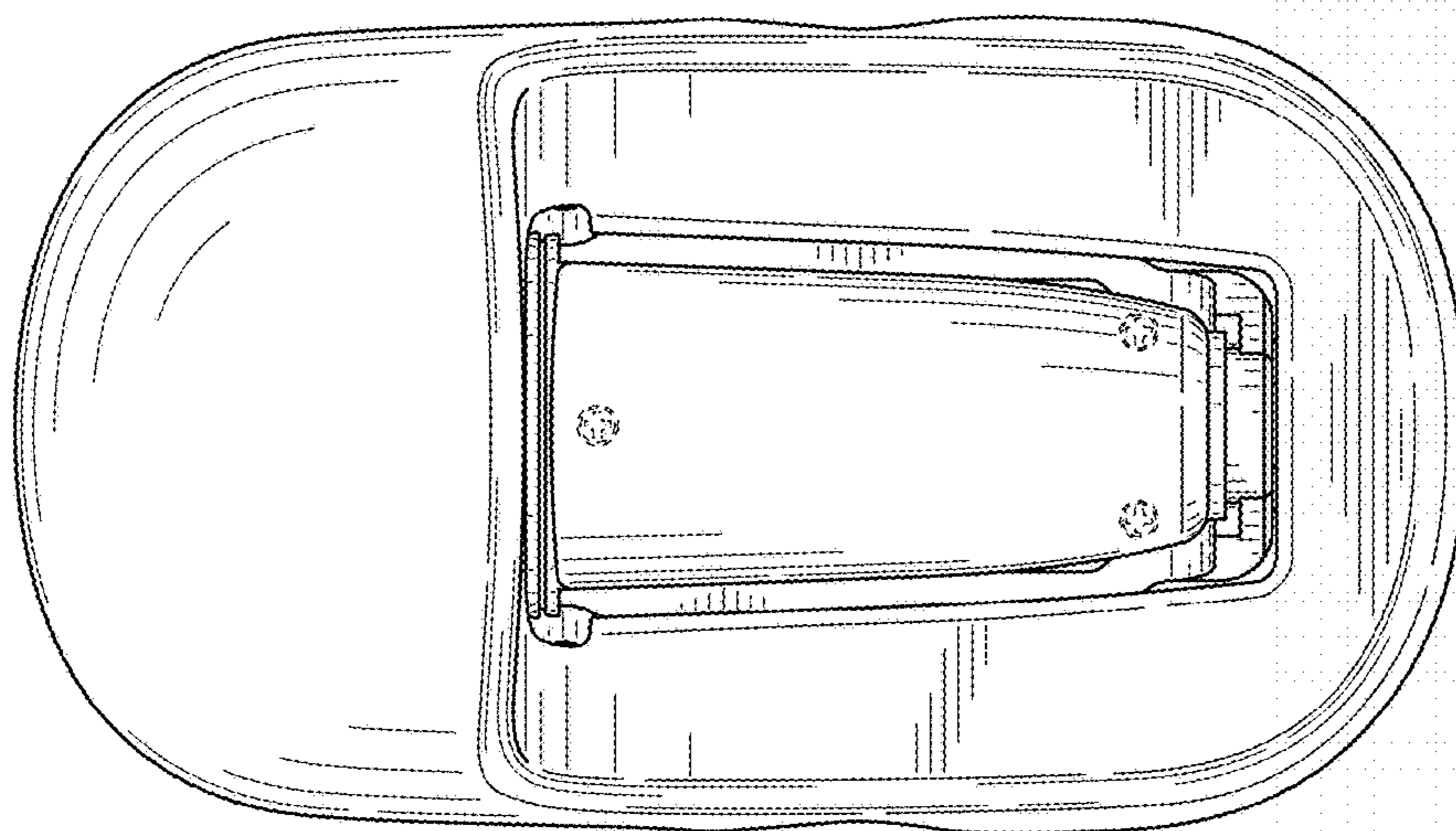

FIG. 2

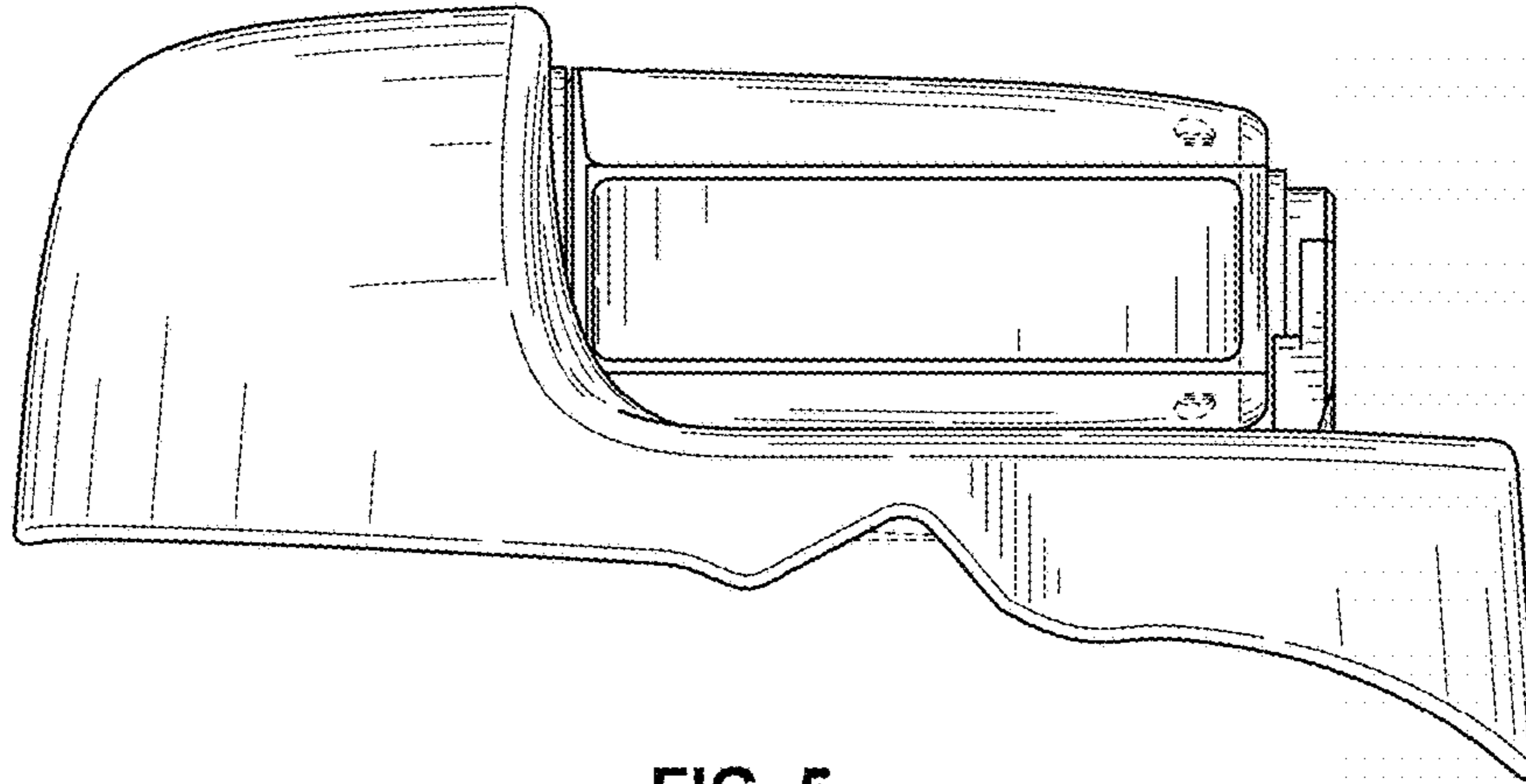

FIG. 5

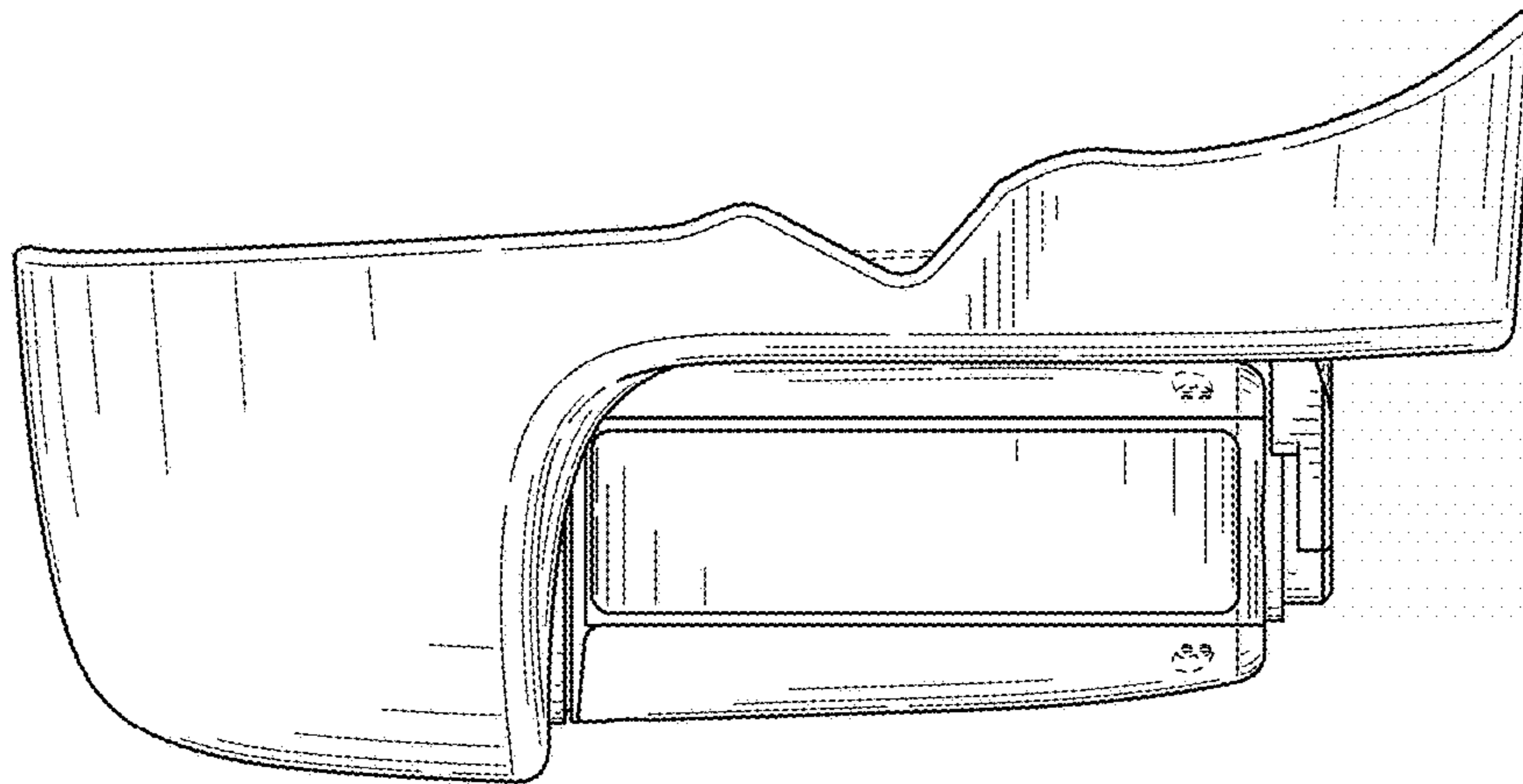

FIG. 4

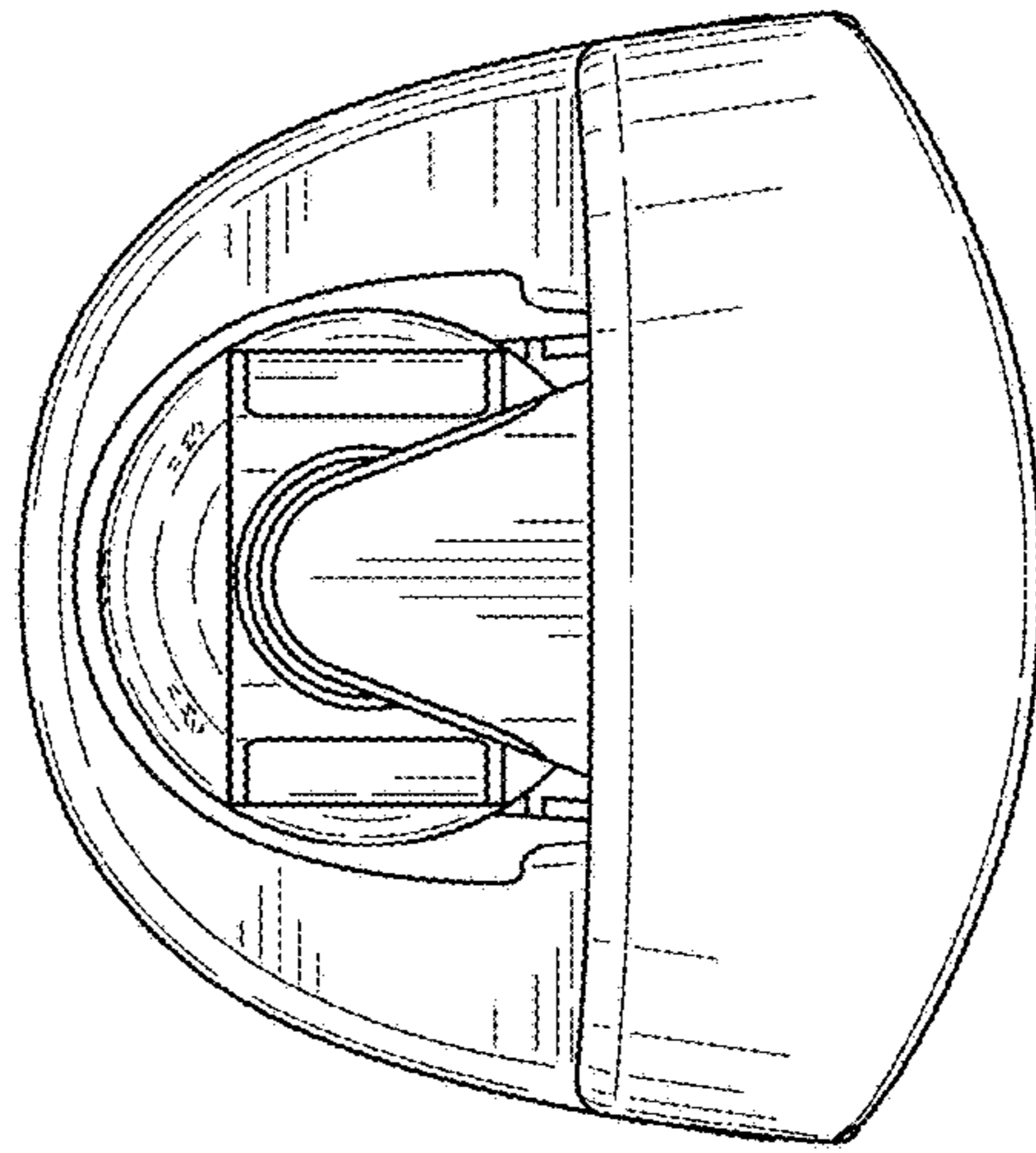

FIG. 7

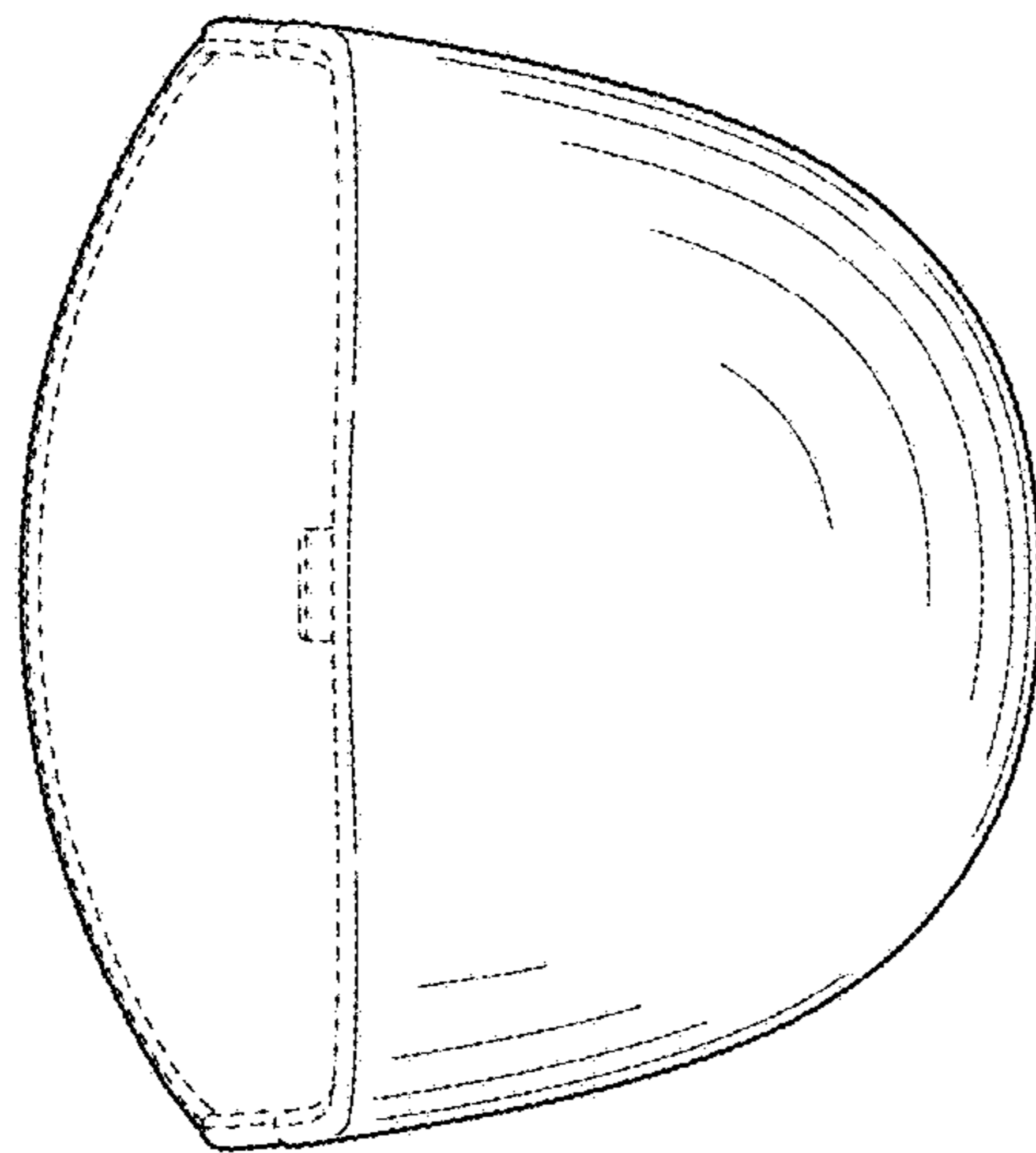
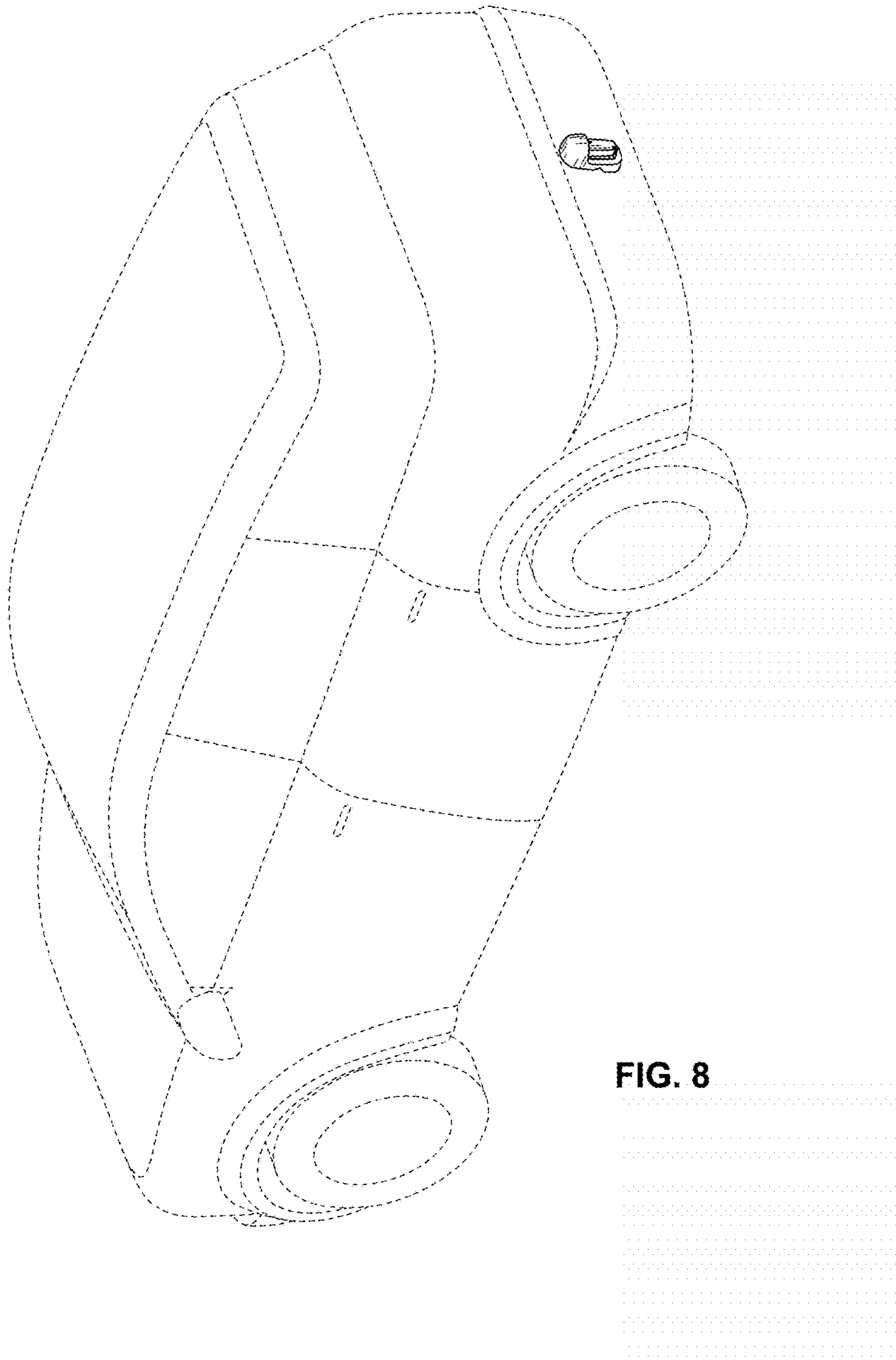

FIG. 6



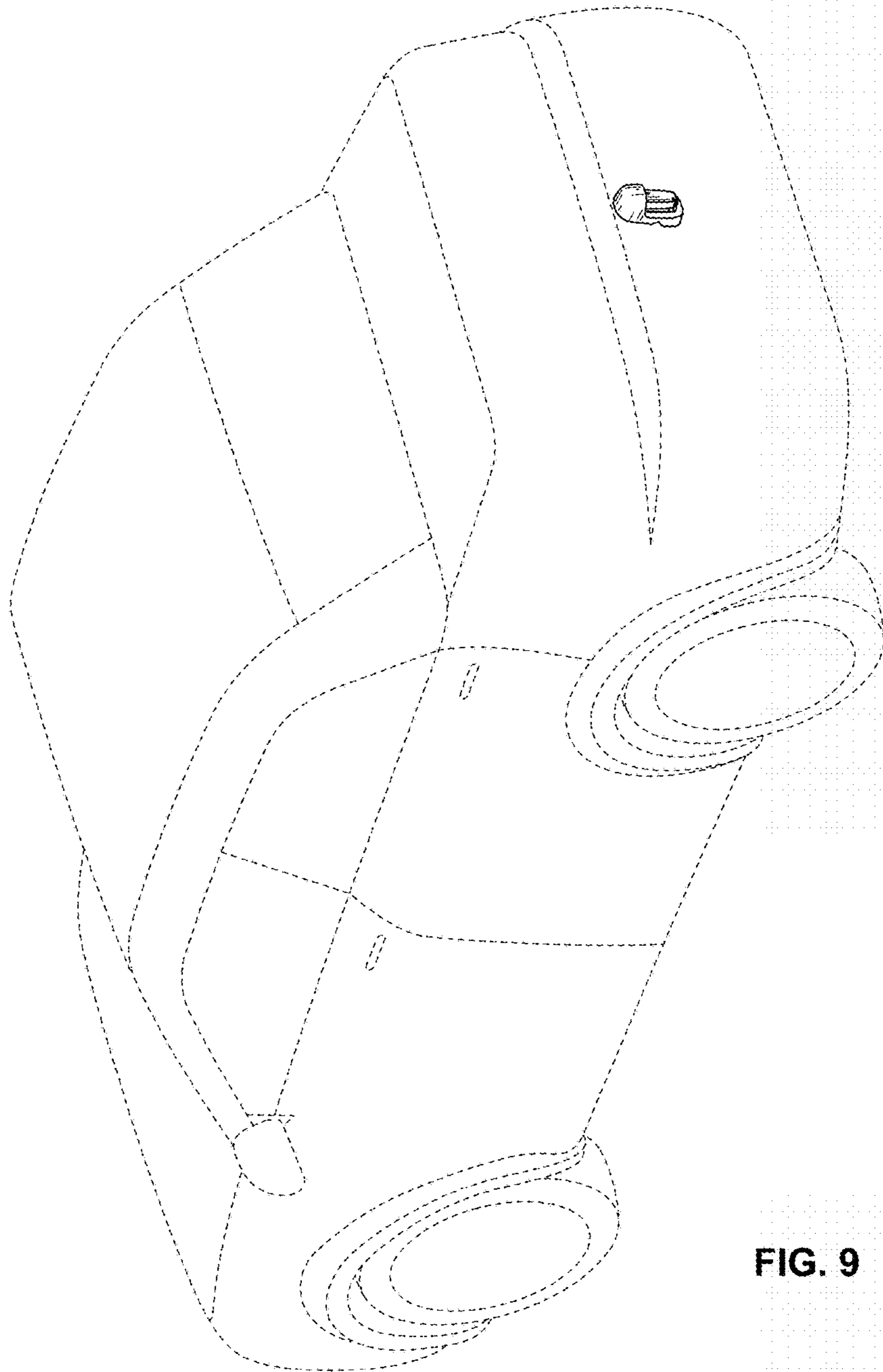

FIG. 9