

US00D859769S

(12) **United States Design Patent**
Burns et al.

(10) **Patent No.:** **US D859,769 S**

(45) **Date of Patent:** **** Sep. 10, 2019**

- (54) **DEBRIS CART**
- (71) Applicant: **RICHARD S. BURNS & COMPANY, INC.**, Philadelphia, PA (US)
- (72) Inventors: **Allen T. Burns**, Philadelphia, PA (US);
Thomas A. Garlick, Langhorne, PA (US); **William Vile**, Turnersville, NJ (US)
- (73) Assignee: **RICHARD S. BURNS & COMPANY, INC.**, Philadelphia, PA (US)

- 3,858,939 A * 1/1975 Bond B60P 1/14
298/20 R
- D240,614 S * 7/1976 Paterno D34/25
- 4,054,301 A * 10/1977 Bond B60P 1/18
280/400
- 4,129,314 A * 12/1978 Bond B60P 1/18
280/425.1
- 4,162,086 A * 7/1979 Bond B60P 1/14
280/425.1
- 4,723,887 A * 2/1988 Swain E02F 3/96
280/419
- D301,651 S * 6/1989 Rinkewich D34/20
- D326,171 S * 5/1992 Brenner D34/1

(Continued)

- (**) Term: **15 Years**
- (21) Appl. No.: **29/653,364**
- (22) Filed: **Jun. 14, 2018**

Primary Examiner — Cynthia Ramirez
(74) *Attorney, Agent, or Firm* — Ballard Spahr LLP

(57) **CLAIM**

The ornamental design for a debris cart, as shown and described.

Related U.S. Application Data

- (62) Division of application No. 29/561,274, filed on Apr. 14, 2016, now Pat. No. Des. 822,932.
- (51) **LOC (12) Cl.** **09-09**
- (52) **U.S. Cl.**
USPC **D34/5; D34/25**
- (58) **Field of Classification Search**
USPC D34/1, 3, 4, 10, 11, 12, 14, 19, 25;
220/908, 908.1, 1.5; D6/675; 280/47.35
CPC B65D 90/0033; B65D 90/18; B65D 90/24;
B65D 88/123; B65D 88/747
See application file for complete search history.

DESCRIPTION

FIG. 1 is a top perspective view of a debris cart showing my new design;
 FIG. 2 is a front elevational view of the debris cart of FIG. 1, the rear elevational view of the debris cart being a mirror image thereof;
 FIG. 3 is a left side elevational view of the debris cart of FIG. 1;
 FIG. 4 is a right side elevational view of the debris cart of FIG. 1;
 FIG. 5 is a top plan view of the debris cart of FIG. 1; and,
 FIG. 6 is a bottom plan view of the debris cart of FIG. 1.
 The dash-dash-dash broken lines shown in the figures are for purposes of illustrating environment only and form no part of the claimed design.
 The debris cart is shown with a symbolic break in its length. The appearance of any portion of the article between the break lines forms no part of the claimed design.

(56) **References Cited**

U.S. PATENT DOCUMENTS

- D202,493 S * 10/1965 Gribbens D34/20
- 3,366,397 A * 1/1968 Zeilstra B62B 1/10
280/47.26
- 3,788,702 A * 1/1974 Toboll B60P 1/18
105/378

1 Claim, 3 Drawing Sheets

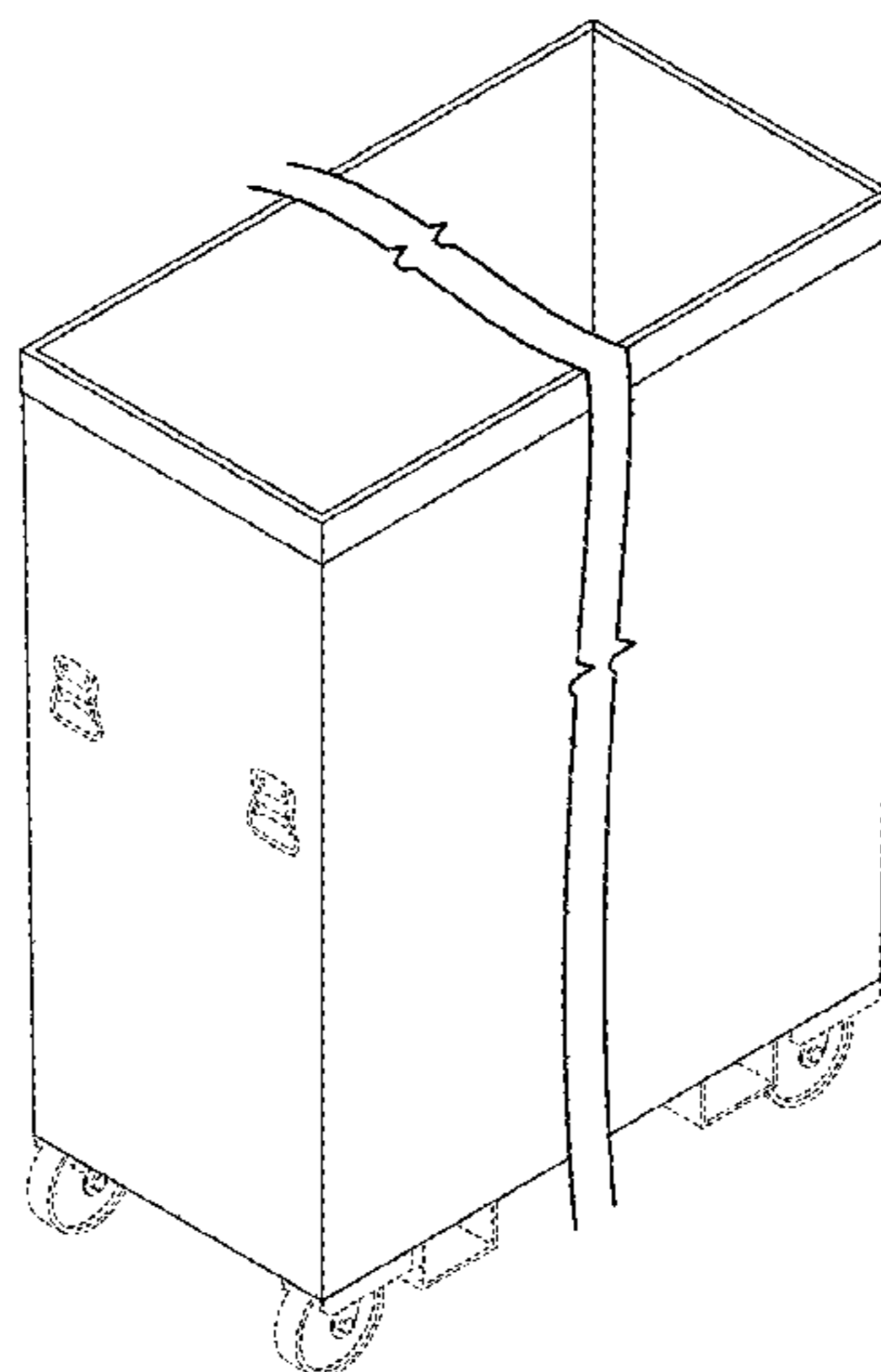

(56)

References Cited

U.S. PATENT DOCUMENTS

D326,198 S * 5/1992 Pacetti D34/19
5,213,367 A * 5/1993 Norman, Jr. B60P 3/224
182/113
5,529,177 A * 6/1996 Podd B65D 88/747
206/204
D821,675 S * 6/2018 Burns D34/5
D822,932 S * 7/2018 Burns D34/5
D844,277 S * 3/2019 Olson D34/19

* cited by examiner

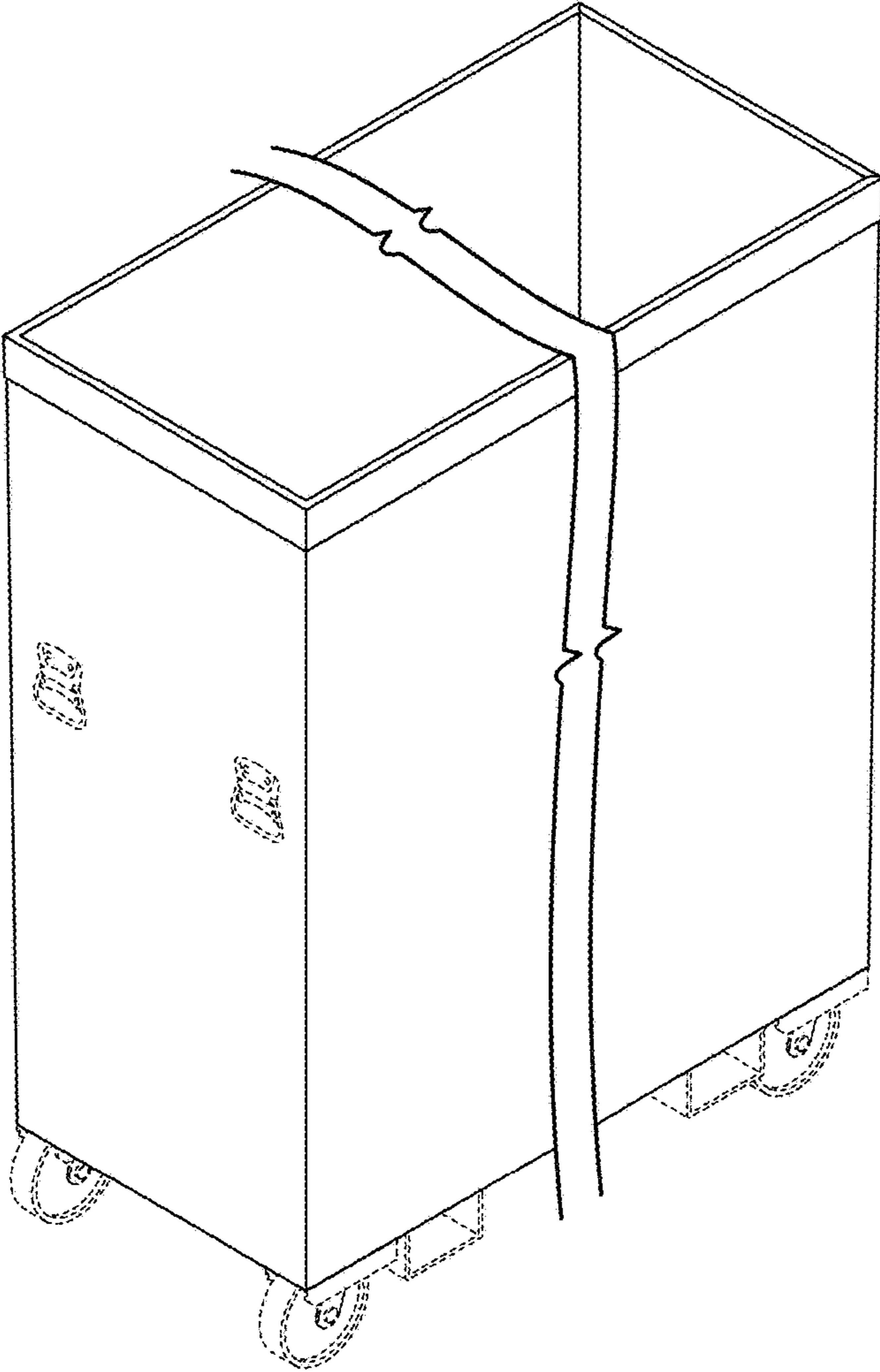

FIG. 1

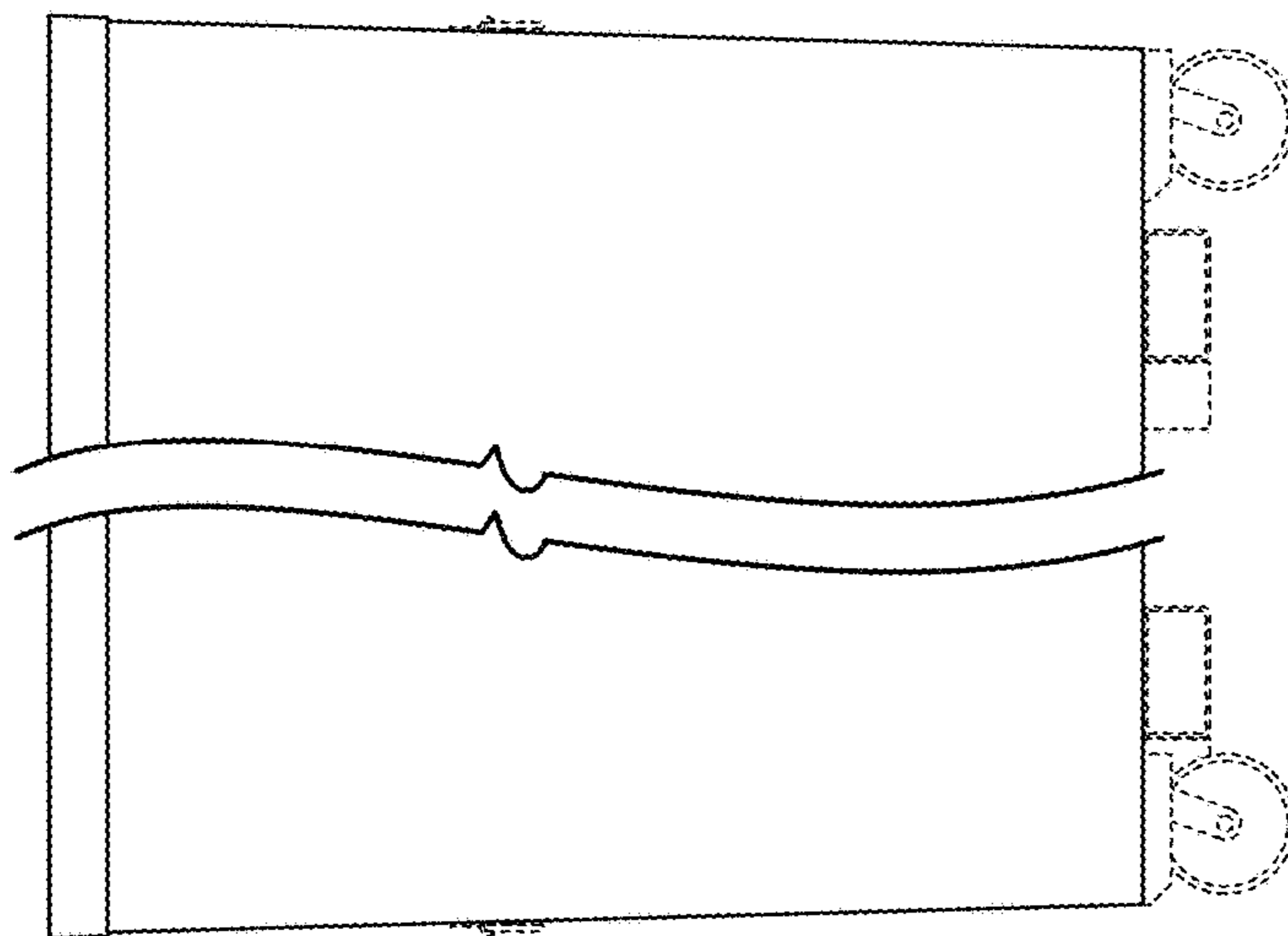

FIG. 2

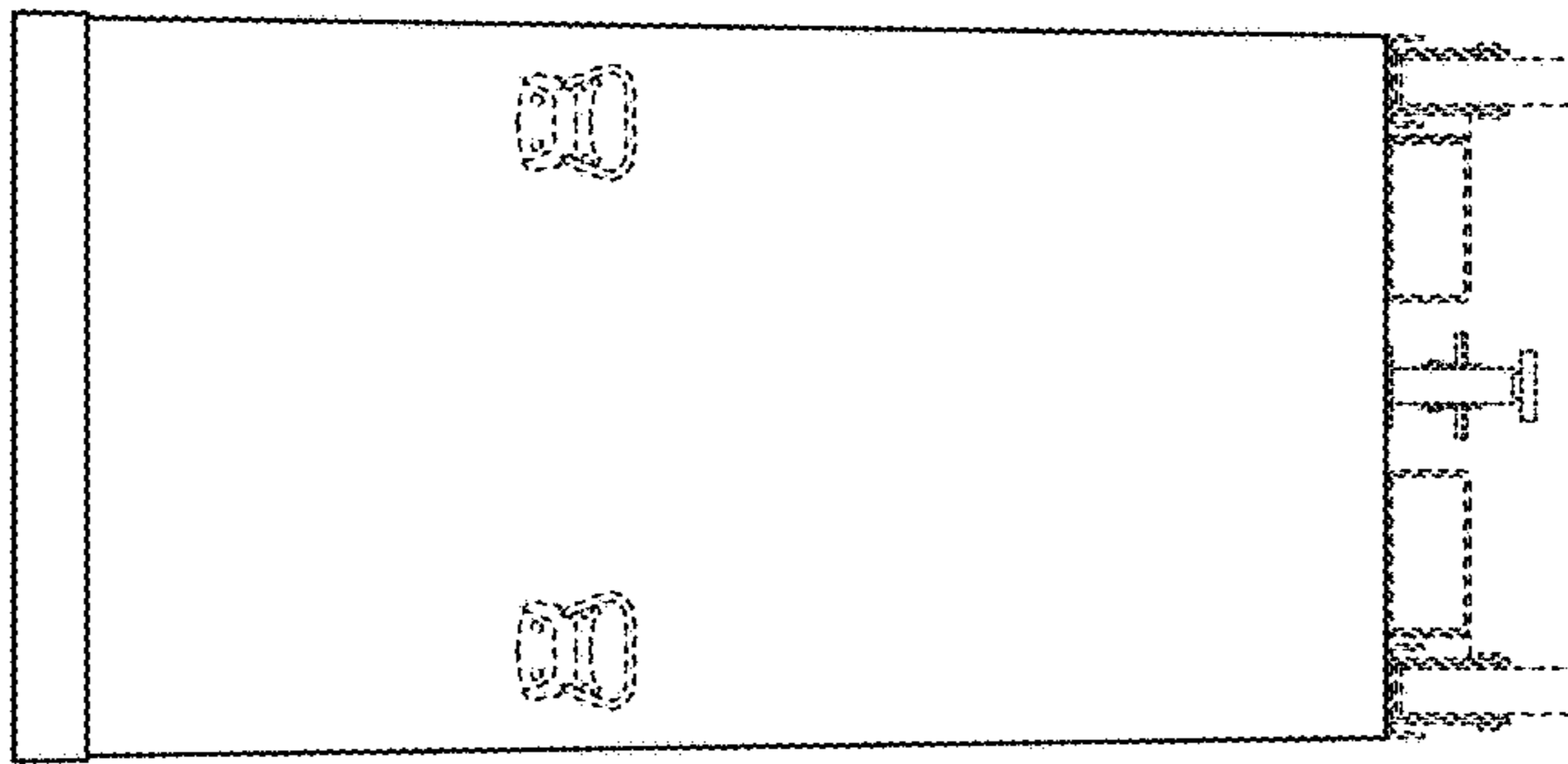

FIG. 3

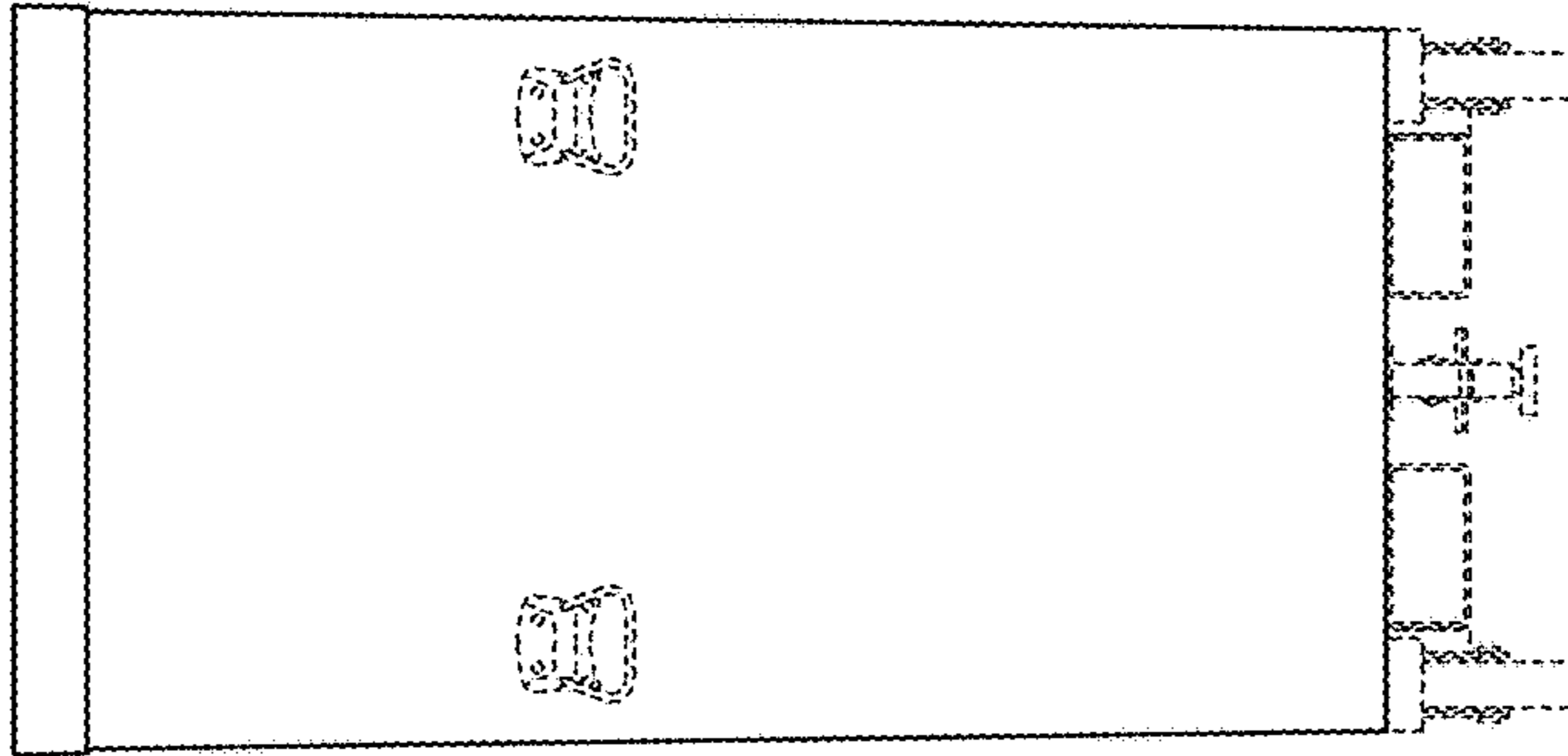

FIG. 4

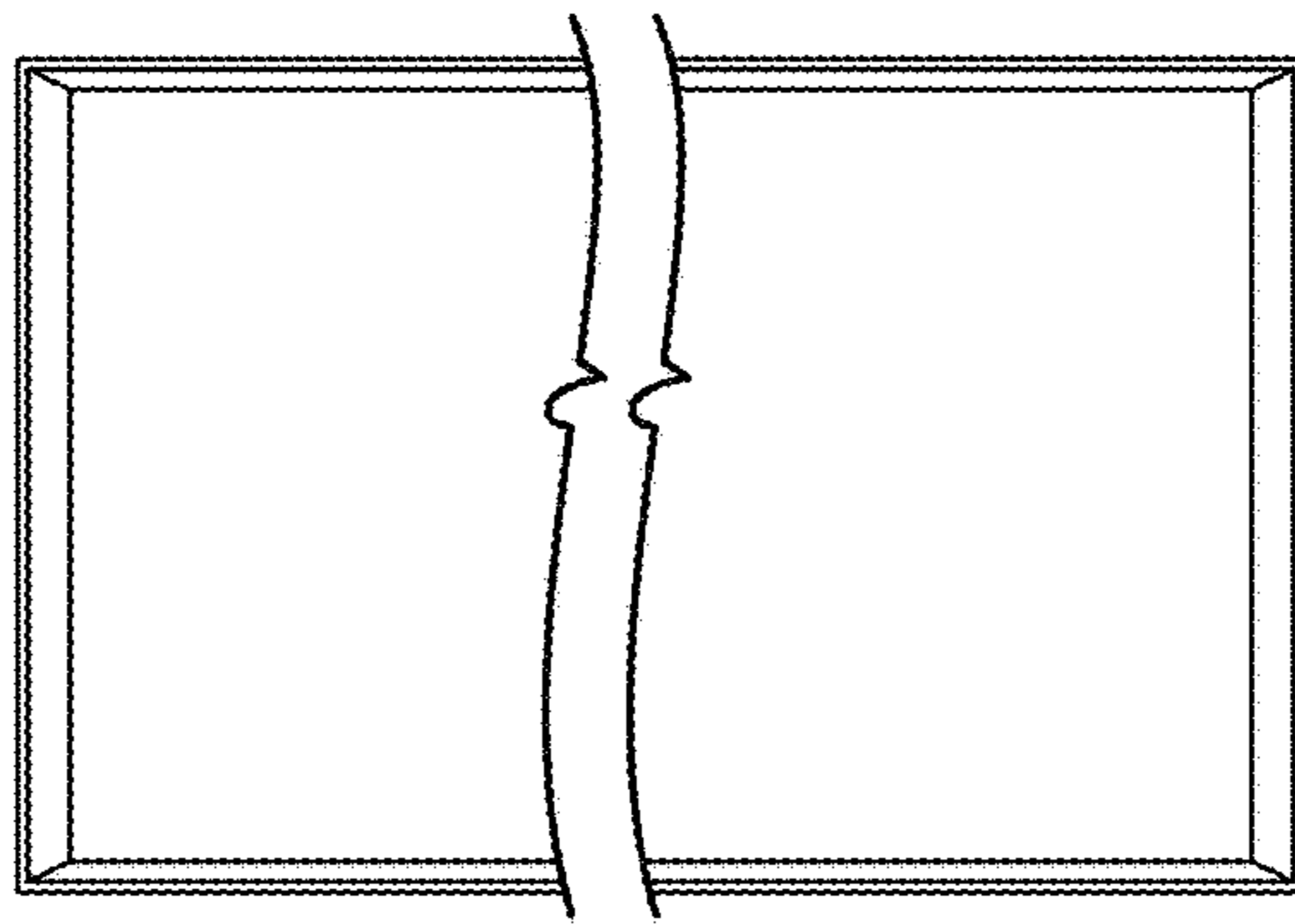

FIG. 5

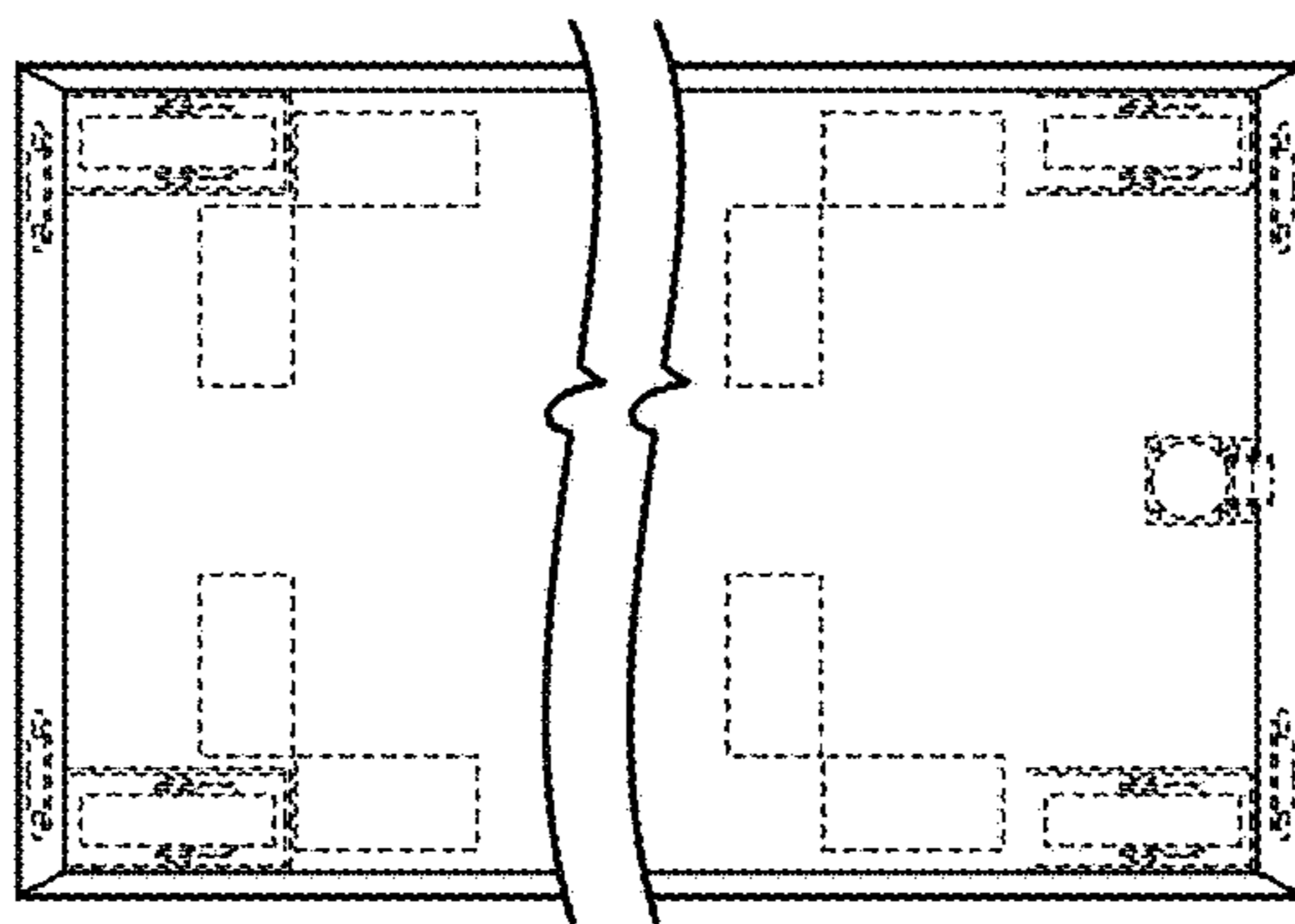

FIG. 6