



US00D859689S

(12) **United States Design Patent** (10) **Patent No.:** **US D859,689 S**
Vaghi (45) **Date of Patent:** **** Sep. 10, 2019**

(54) **COMBINATION PARKING STRUCTURE AND TRAIN STATION**

(71) Applicant: **NINO R. VAGHI FOUNDATION**,
Kensington, MD (US)

(72) Inventor: **Nino R. Vaghi**, Kensington, MD (US)

(73) Assignee: **Nino R. Vaghi Foundation**,
Kensington, MD (US)

(**) Term: **15 Years**

(21) Appl. No.: **29/657,690**

(22) Filed: **Jul. 24, 2018**

(51) **LOC (12) Cl.** **D25-03**

(52) **U.S. Cl.**
USPC **D25/3; D25/31**

(58) **Field of Classification Search**
USPC D25/1-34, 57-61
CPC E04H 1/00-14; E04H 3/00-10; E04H
3/12-30; E04H 6/00; E04H 6/08-10
See application file for complete search history.

(56) **References Cited**

U.S. PATENT DOCUMENTS

D149,076 S *	3/1948	Loewy	D25/30
D181,555 S *	11/1957	Sullivan	D25/34
D193,470 S *	8/1962	Kimball	D25/18
3,319,385 A *	5/1967	Szpytman		
3,485,000 A *	12/1969	Fiquet	E04B 1/3211 D25/19
D391,646 S *	3/1998	Broudy	D25/1
6,279,855 B1 *	8/2001	Domer	E04H 3/00 244/114 R
D486,237 S *	2/2004	Henry	D25/1
D490,906 S *	6/2004	Small	D25/31

8,915,669 B1	12/2014	Gustafson et al.	
9,267,306 B2	2/2016	Suhami	
2005/0280555 A1	12/2005	Warner, IV	
2011/0214364 A1 *	9/2011	Fuller E04H 1/04 52/173.3
2014/0123574 A1 *	5/2014	Paone E04H 1/005 52/79.12
2016/0340923 A1	11/2016	Stauffer	

FOREIGN PATENT DOCUMENTS

CN	102383636 A	3/2012
WO	2010062204 A1	6/2010

* cited by examiner

Primary Examiner — Brett Miller

(74) *Attorney, Agent, or Firm* — Richard C. Litman

(57) **CLAIM**

The ornamental design for a combination parking structure and train station, as shown and described.

DESCRIPTION

FIG. 1 is a perspective view of a combination parking structure and train station showing my design; FIG. 2 is a plan view thereof; FIG. 3 is a front elevational view thereof; FIG. 4 is a rear elevational view thereof; FIG. 5 is a left side elevational view thereof; FIG. 6 is a right side elevational view thereof; and, FIG. 7 is a perspective view thereof, shown without environmental subject matter.

The broken line showing of the roadway and ramps in FIGS. 1-6 is for illustrative purposes only and forms no part of the claimed design.

A bottom view of the combination parking structure and train station is flat and unornamental.

1 Claim, 5 Drawing Sheets

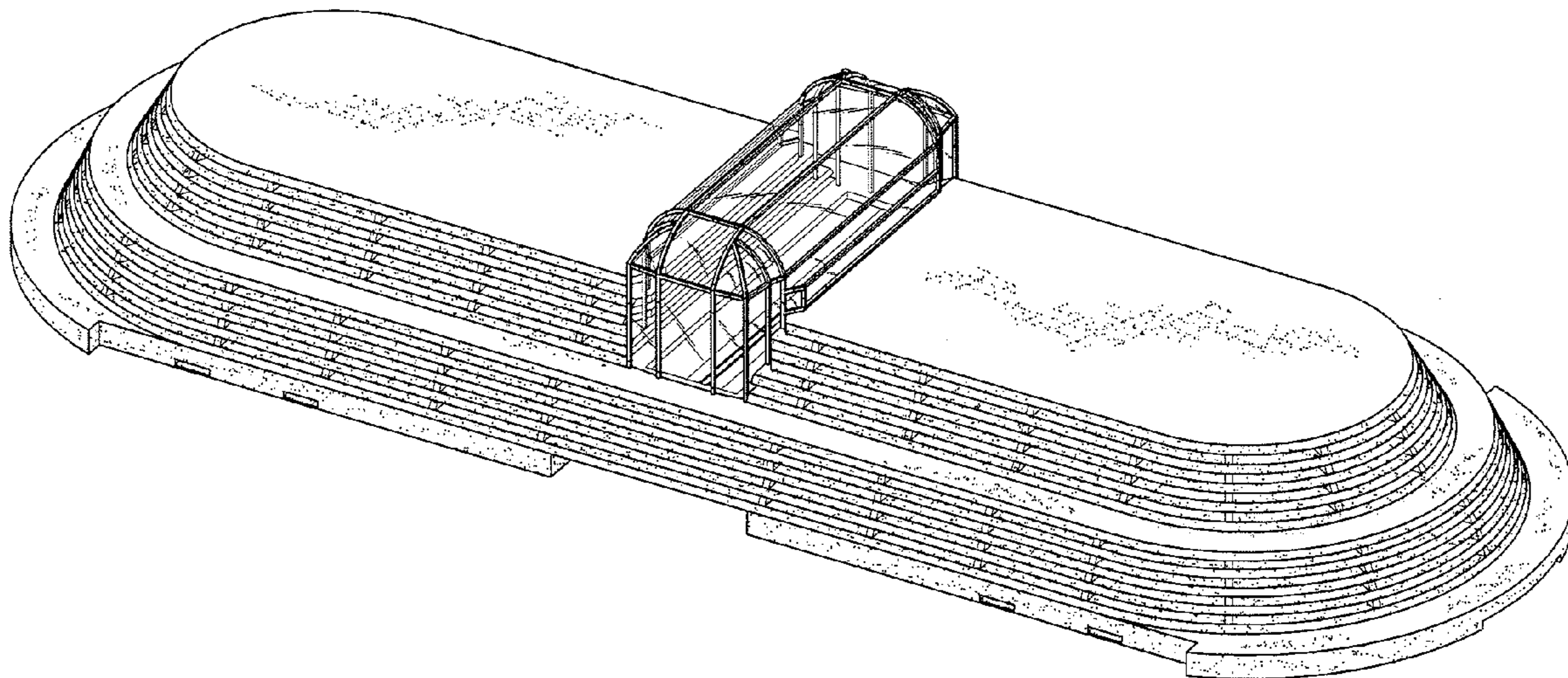

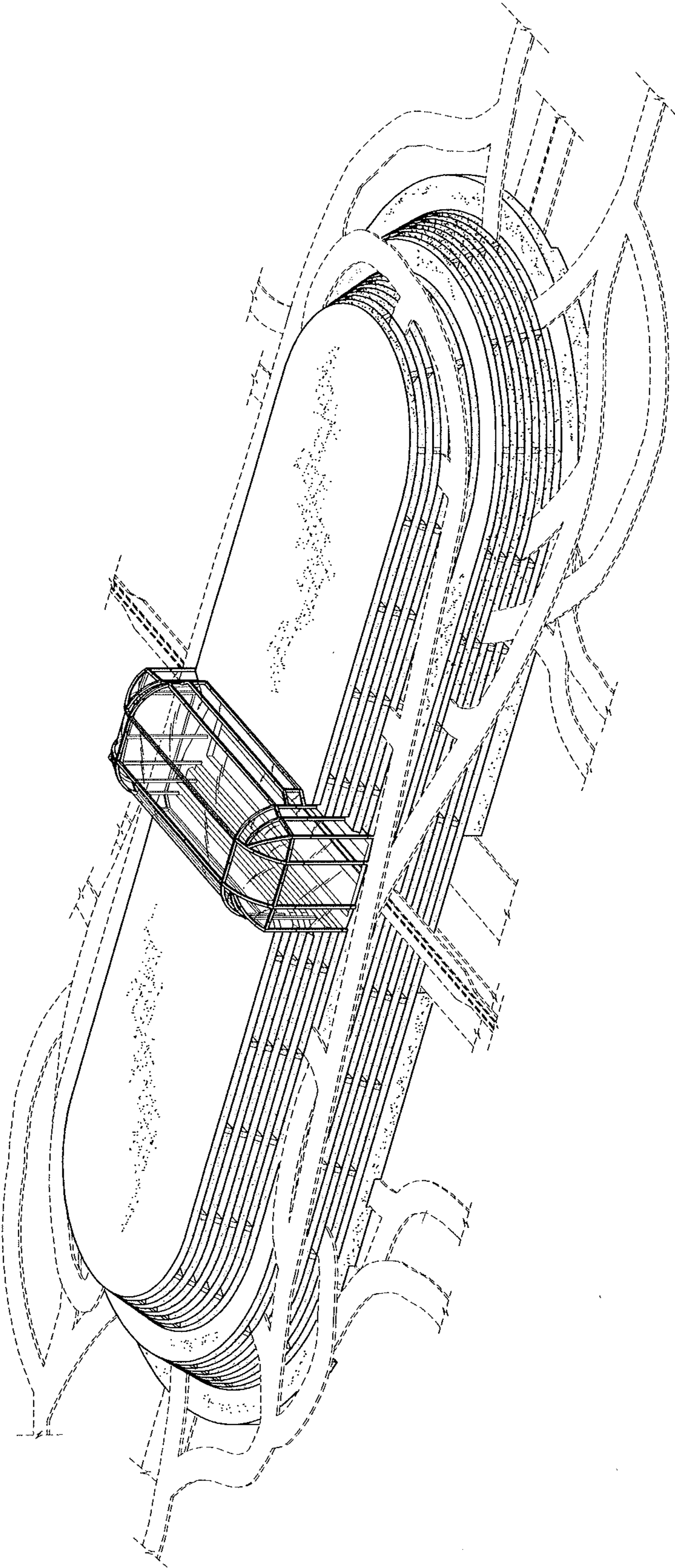

FIG. 1

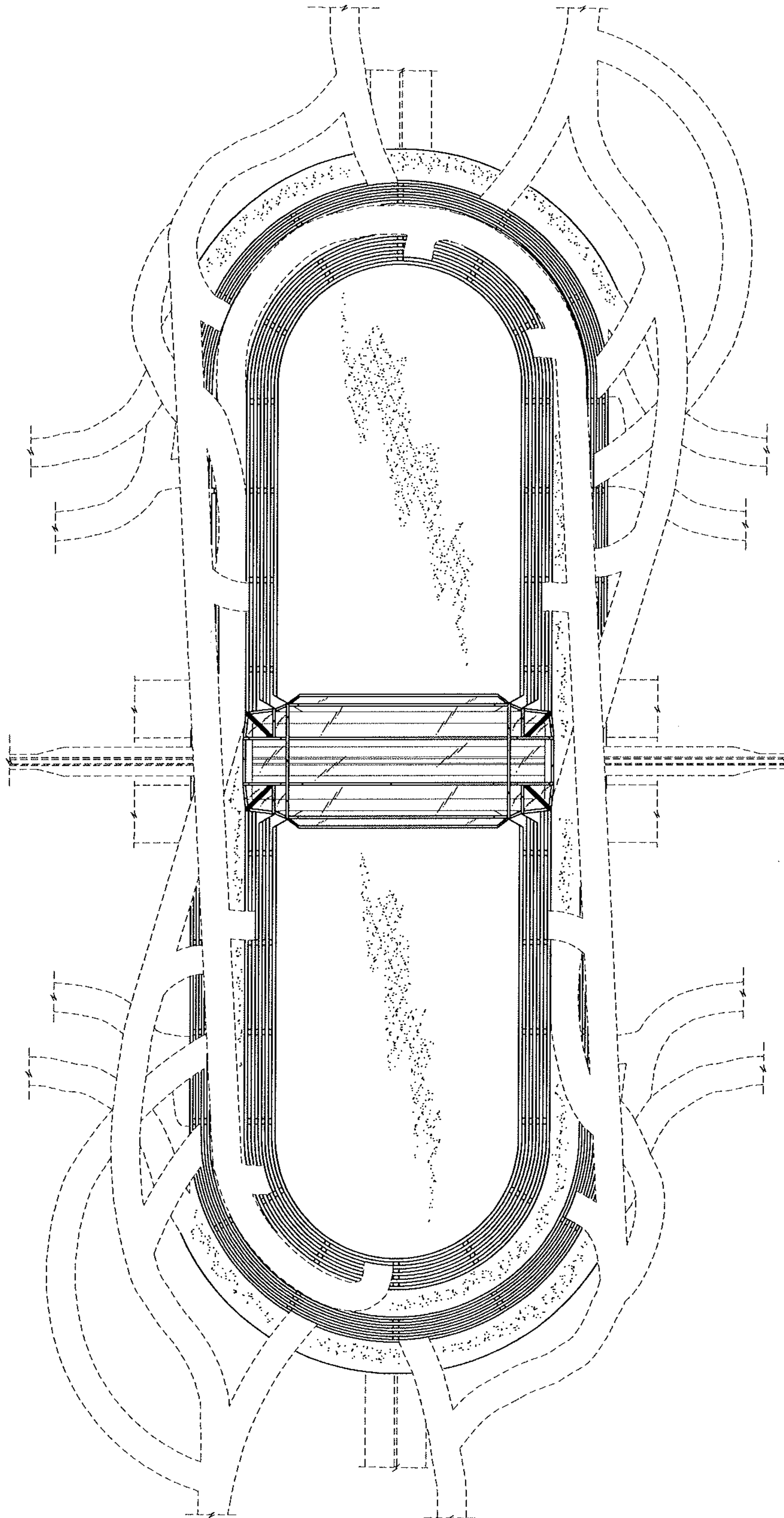

FIG. 2

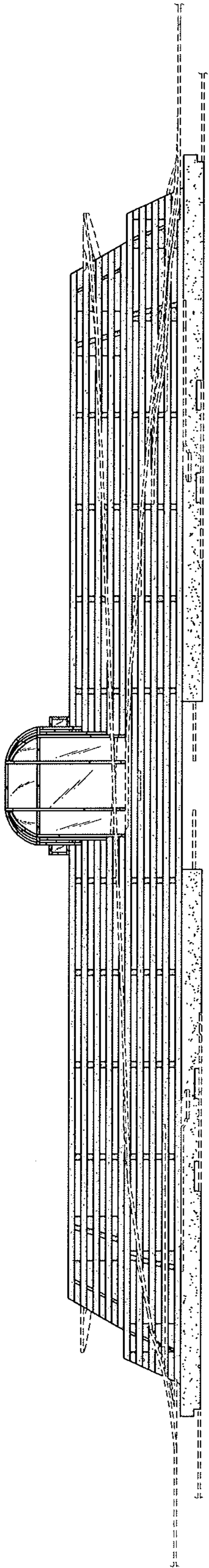

FIG. 3

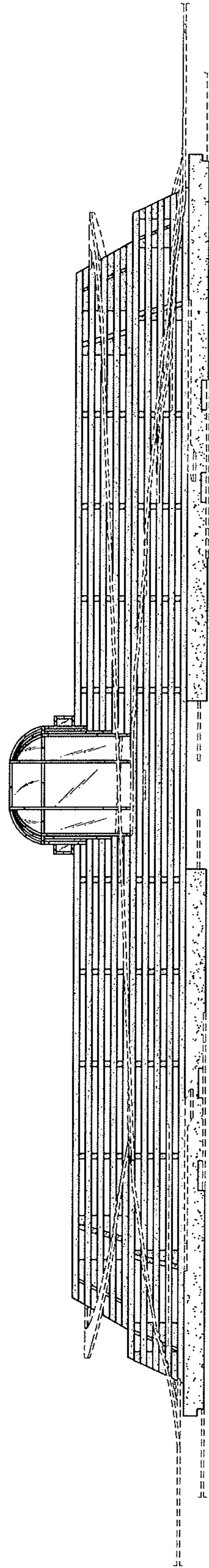

FIG. 4

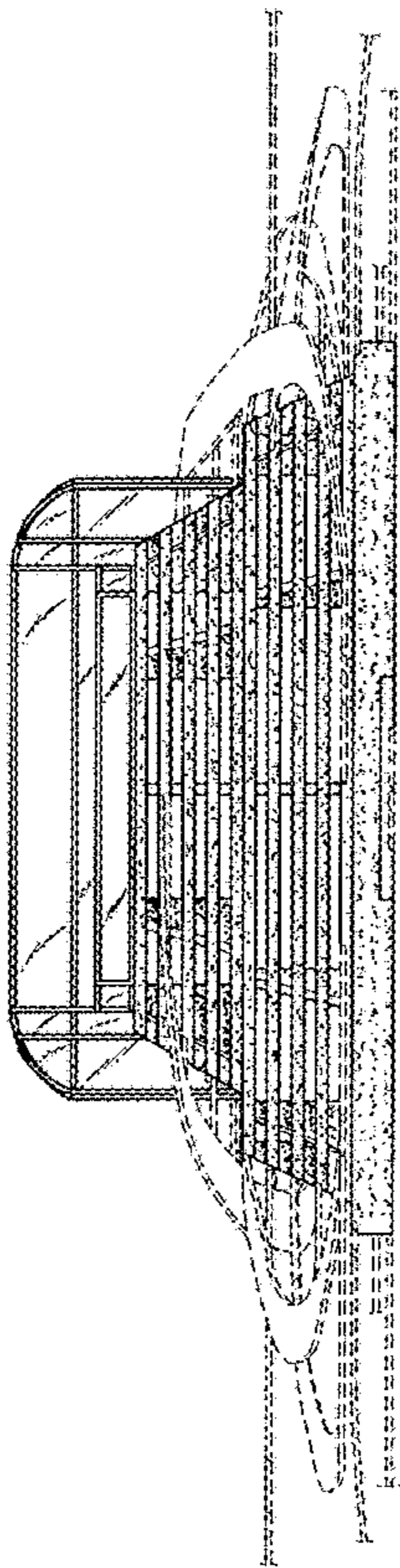

FIG. 5

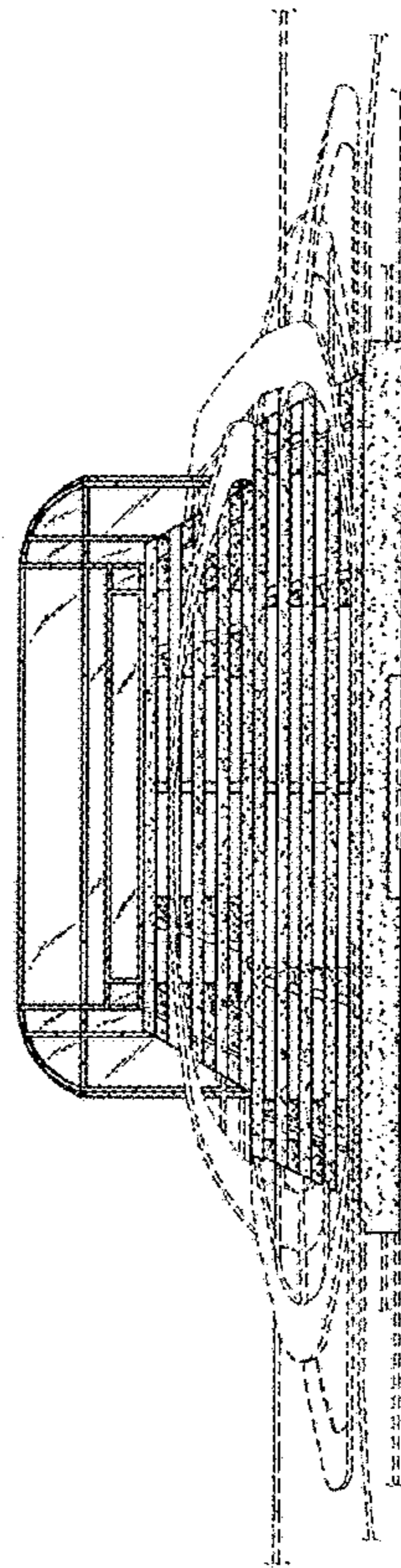

FIG. 6

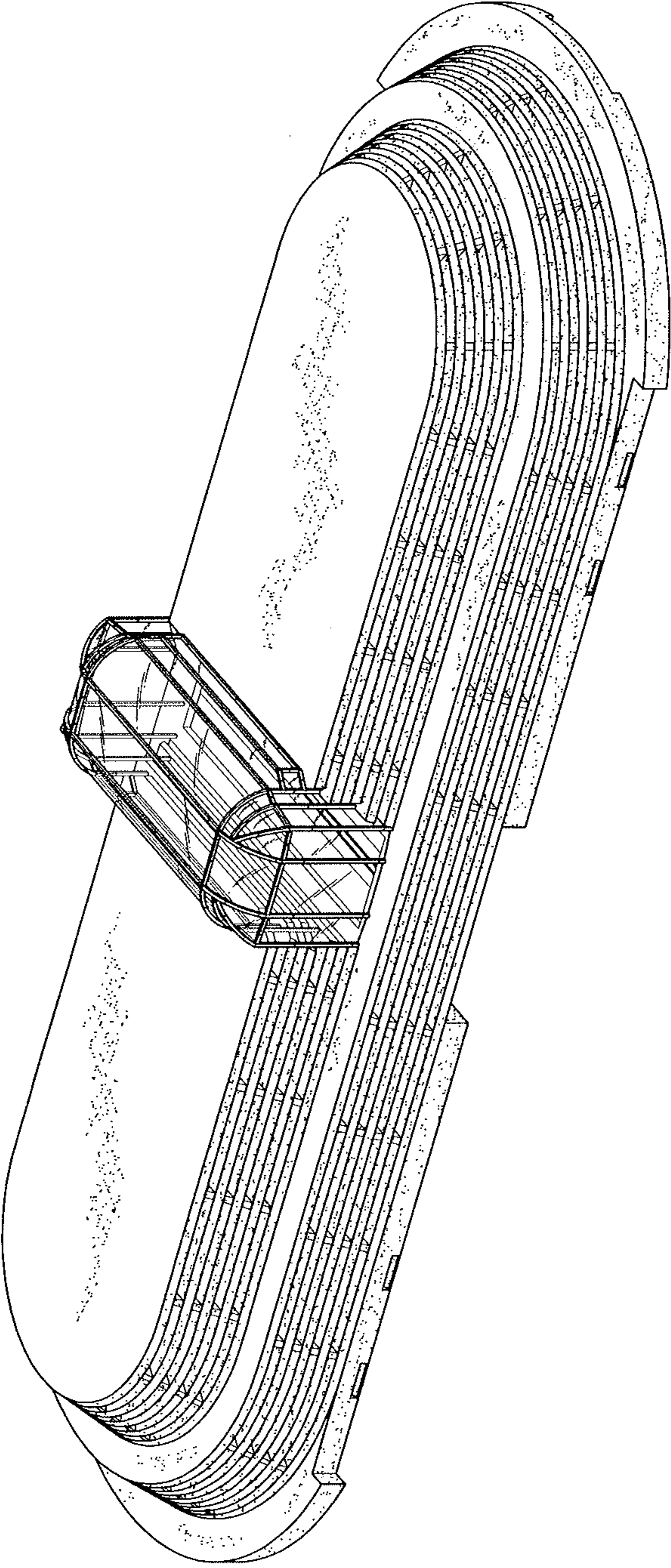

FIG. 7