



US00D859365S

(12) **United States Design Patent**  
**Kitamura et al.**

(10) **Patent No.:** **US D859,365 S**

(45) **Date of Patent:** **\*\* Sep. 10, 2019**

- (54) **SPEAKER FOR AUTOMOBILE**
- (71) Applicant: **PIONEER CORPORATION**, Tokyo (JP)
- (72) Inventors: **Meiji Kitamura**, Tokyo (JP); **Chie Wakasa**, Tokyo (JP)
- (73) Assignee: **PIONEER CORPORATION**, Tokyo (JP)

(\*\*) Term: **15 Years**

(21) Appl. No.: **29/638,401**

(22) Filed: **Feb. 27, 2018**

(30) **Foreign Application Priority Data**

Sep. 5, 2017 (JP) ..... 2017-019173

(51) **LOC (12) Cl.** ..... **14-03**

(52) **U.S. Cl.**  
USPC ..... **D14/216**; D14/221

(58) **Field of Classification Search**  
USPC ..... D14/216, 215, 221, 222, 208, 219, 210;  
181/144-148, 156, 170, 173, 141, 182,  
181/396, 186; 381/380, 381, 421, 423,  
381/426, 427, 397, 186, 182, 412, 385,  
381/409; 455/90.3, 575.1, 569.1  
CPC ... H04R 1/20; H04R 9/06; H04R 9/04; H04R  
1/00; H04R 1/24; H04R 25/00  
See application file for complete search history.

(56) **References Cited**

**U.S. PATENT DOCUMENTS**

- 2,538,621 A \* 1/1951 Hopkins ..... H04R 9/045  
174/1
- D188,542 S \* 8/1960 Levy ..... D14/216
- 3,055,991 A \* 9/1962 Guss ..... H04R 9/025  
381/401
- D197,716 S \* 3/1964 Boldt ..... D14/216
- D225,069 S \* 11/1972 May ..... D14/216

- 3,711,659 A \* 1/1973 Bremseth ..... H04R 9/046  
336/223
  - D250,586 S \* 12/1978 Nussdorfer ..... D14/216
  - 4,320,263 A \* 3/1982 Thiele ..... H04R 9/027  
381/415
  - 4,336,425 A \* 6/1982 Renkus ..... H04R 7/127  
29/594
  - D270,909 S \* 10/1983 Iijima ..... D14/216
- (Continued)

**FOREIGN PATENT DOCUMENTS**

- JP 1329110 S 5/2008
- JP 1519045 S 3/2015

**OTHER PUBLICATIONS**

Pioneer Catalog published in 2016, Audio & AV 2017 Car Entertainment Dealer Reference Guide vol. 1, pp. 74, 75, 78, 79, 82, 83, 88 and 89.

*Primary Examiner* — Paula Allen Greene

(74) *Attorney, Agent, or Firm* — Drinker Biddle & Reath LLP

(57) **CLAIM**

The ornamental design for the speaker for automobile, as shown and described.

**DESCRIPTION**

FIG. 1 is a perspective view of a speaker for automobile showing our new design;  
FIG. 2 is a front view thereof;  
FIG. 3 is a rear view thereof;  
FIG. 4 is a top view thereof;  
FIG. 5 is a bottom view thereof  
FIG. 6 is a right side view thereof; and,  
FIG. 7 is a left side view thereof.  
The broken line showing of the speaker for automobile is included for the purpose of illustrating portions of the speaker for automobile and forms no part of the claimed design.

**1 Claim, 7 Drawing Sheets**

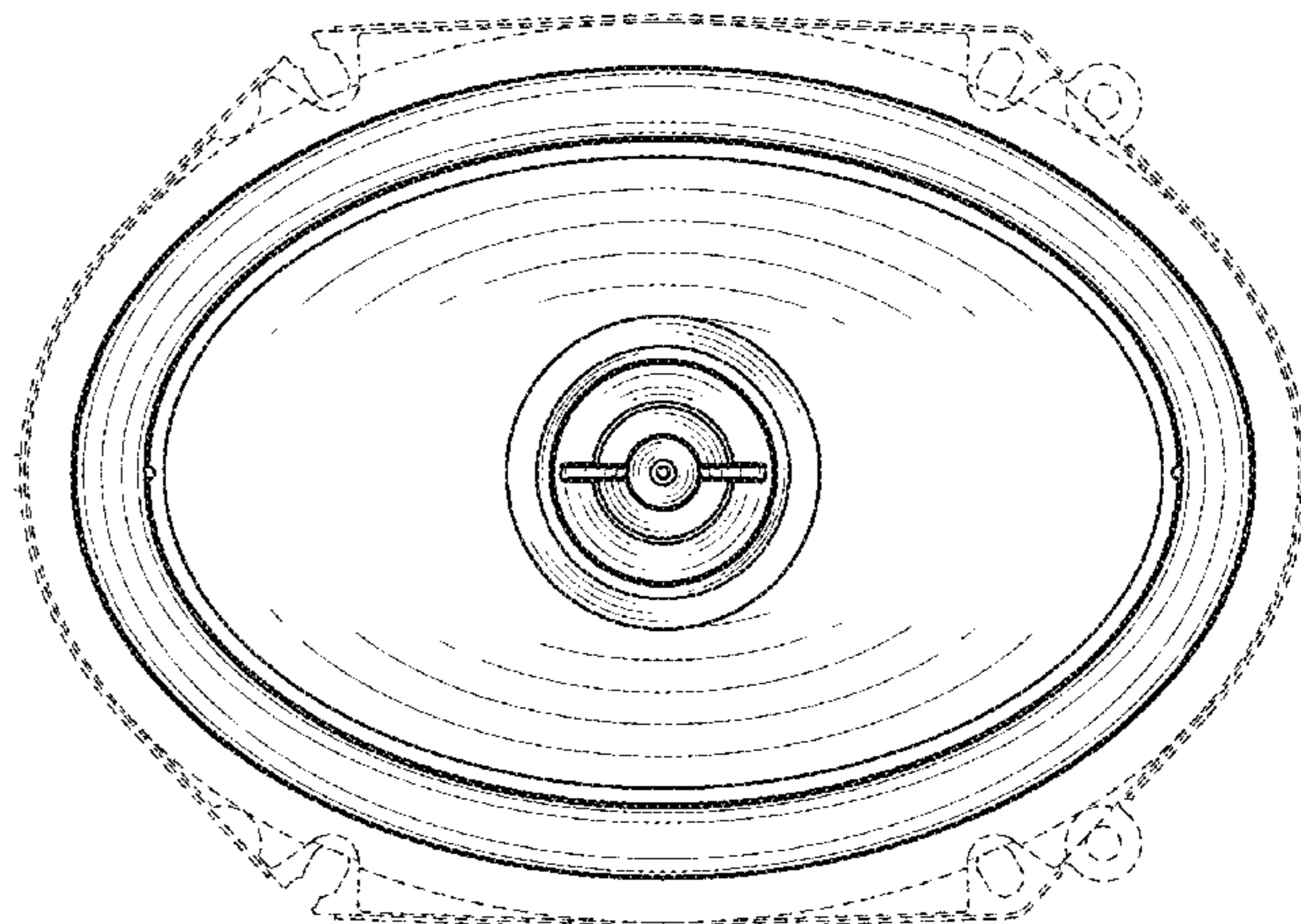
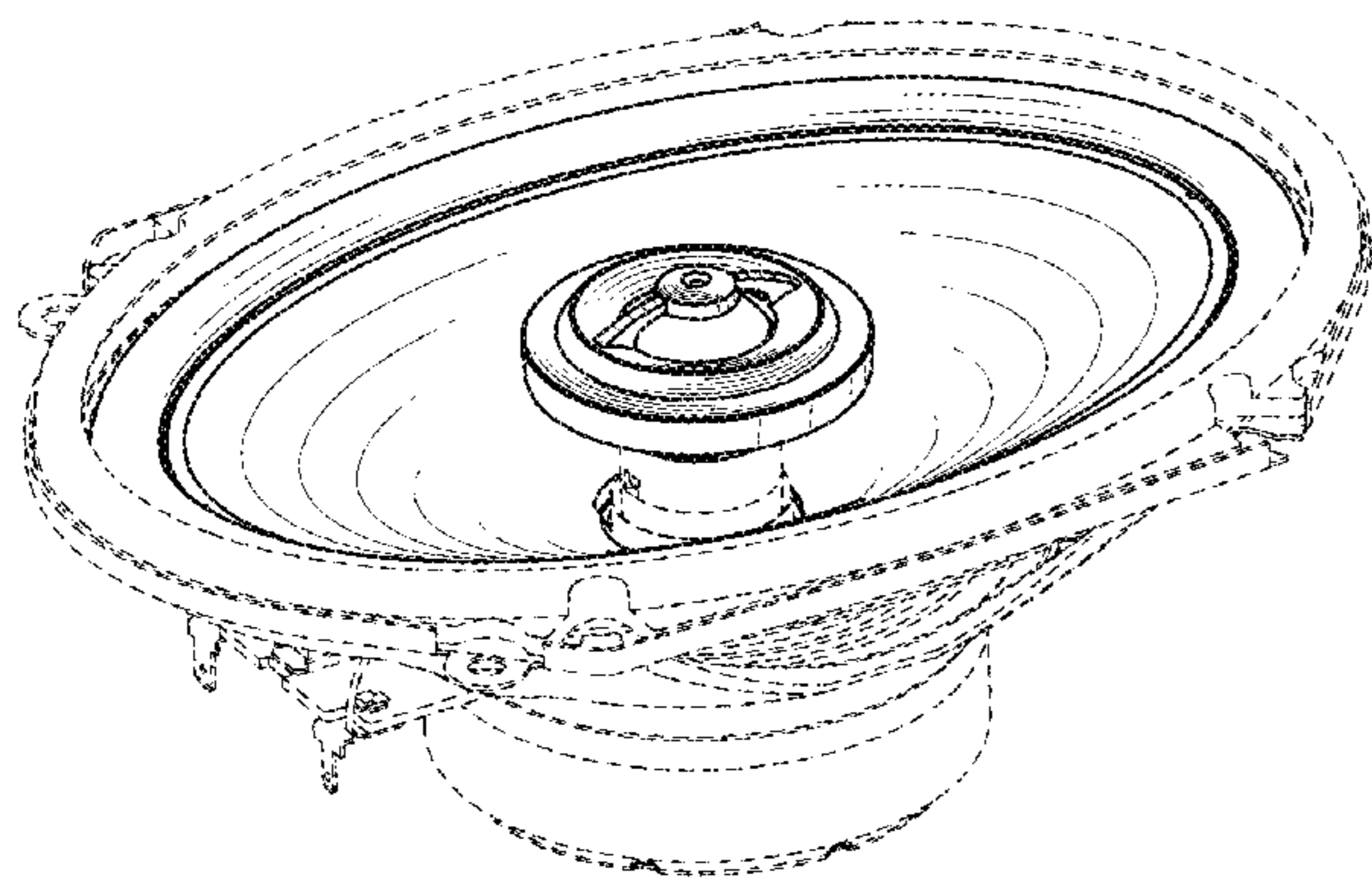

(56)

References Cited

U.S. PATENT DOCUMENTS

D289,041 S \* 3/1987 Bittencourt ..... D14/216  
 D320,020 S \* 9/1991 Iwano ..... D14/216  
 5,133,428 A \* 7/1992 Perrson ..... B60R 11/0217  
 181/153  
 D360,886 S \* 8/1995 Hall ..... D14/216  
 5,548,657 A \* 8/1996 Fincham ..... H04R 1/24  
 381/182  
 5,604,815 A \* 2/1997 Paddock ..... H04R 9/025  
 381/182  
 D393,641 S \* 4/1998 Hai-Fu ..... D14/216  
 5,739,480 A \* 4/1998 Lin ..... H04R 1/24  
 181/144  
 D400,884 S \* 11/1998 Christie, II ..... D14/216  
 D402,988 S \* 12/1998 Shin ..... D14/214  
 6,088,466 A \* 7/2000 Proni ..... H04R 9/02  
 381/397  
 6,095,278 A \* 8/2000 Lin ..... H04R 9/06  
 181/148  
 D432,118 S \* 10/2000 Honnert ..... D14/216  
 6,516,076 B1 \* 2/2003 Marlin ..... G10K 11/004  
 181/159  
 D480,709 S \* 10/2003 Proni ..... D14/216

6,675,930 B2 \* 1/2004 Sugiyama ..... H04R 1/025  
 181/148  
 D488,802 S \* 4/2004 Uehara ..... D14/216  
 D504,416 S \* 4/2005 Dayan ..... D14/216  
 D521,982 S \* 5/2006 Schafernak ..... D14/216  
 D529,899 S \* 10/2006 Amada ..... D14/221  
 D560,658 S \* 1/2008 Akaishi ..... D14/221  
 7,720,248 B2 \* 5/2010 Sasaki ..... H04R 9/06  
 181/148  
 8,422,714 B2 \* 4/2013 Peng ..... H04R 1/2803  
 181/155  
 D705,193 S \* 5/2014 Yoon ..... D14/185  
 8,942,407 B2 \* 1/2015 Dodd ..... H04R 7/02  
 181/157  
 D723,010 S \* 2/2015 Moon ..... D14/222  
 D804,454 S \* 12/2017 Katsuno ..... D14/222  
 D810,050 S \* 2/2018 Uemoto ..... D14/216  
 10,085,079 B2 \* 9/2018 Sato ..... H04R 1/025  
 D840,375 S \* 2/2019 Sakata ..... D14/216  
 2002/0150271 A1 \* 10/2002 Sugiyama ..... H04R 1/06  
 381/386  
 2006/0188123 A1 \* 8/2006 Sasaki ..... H04R 1/021  
 381/386  
 2013/0287246 A1 \* 10/2013 Sasaki ..... H04R 1/06  
 381/412

\* cited by examiner

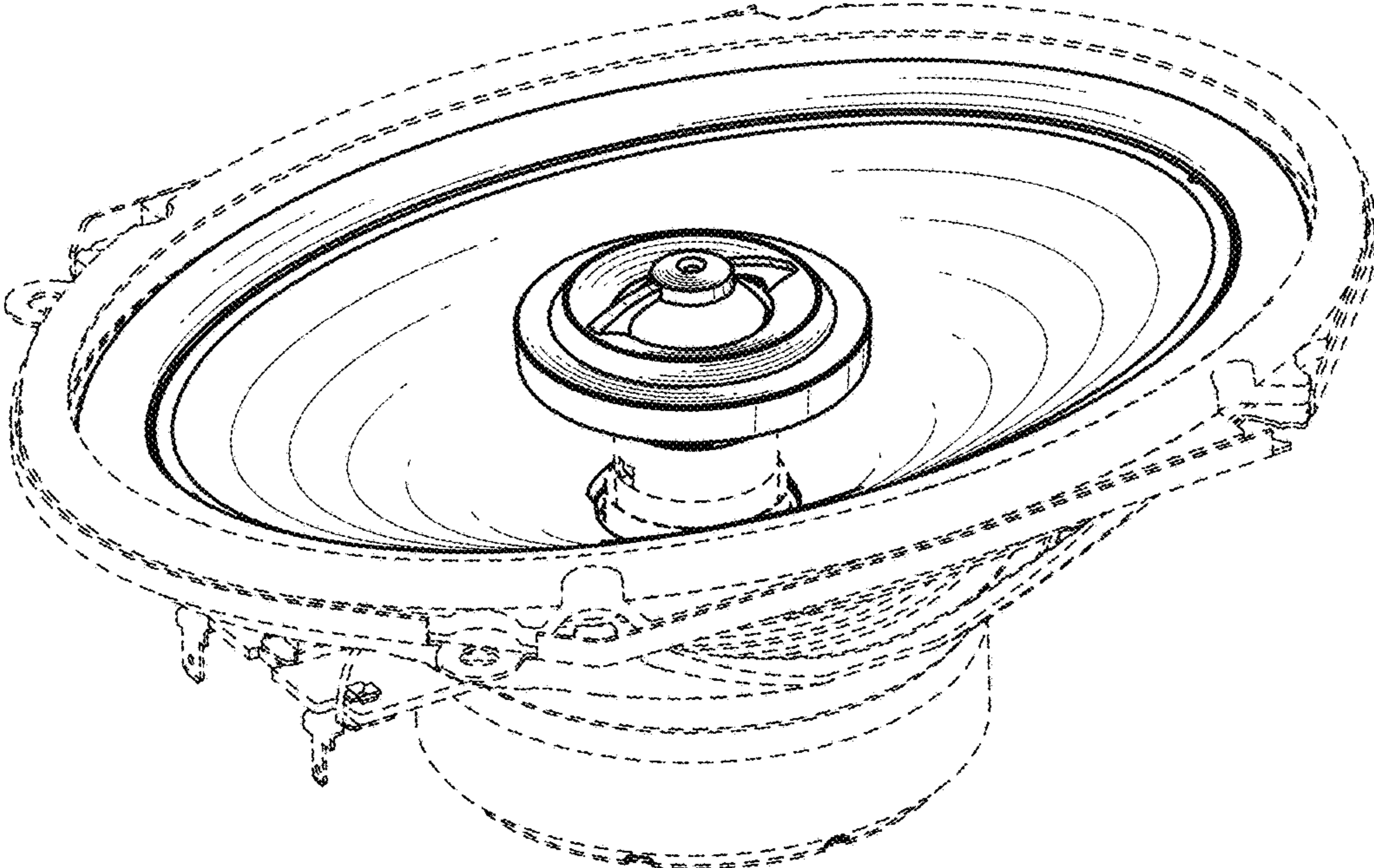

FIG. 1

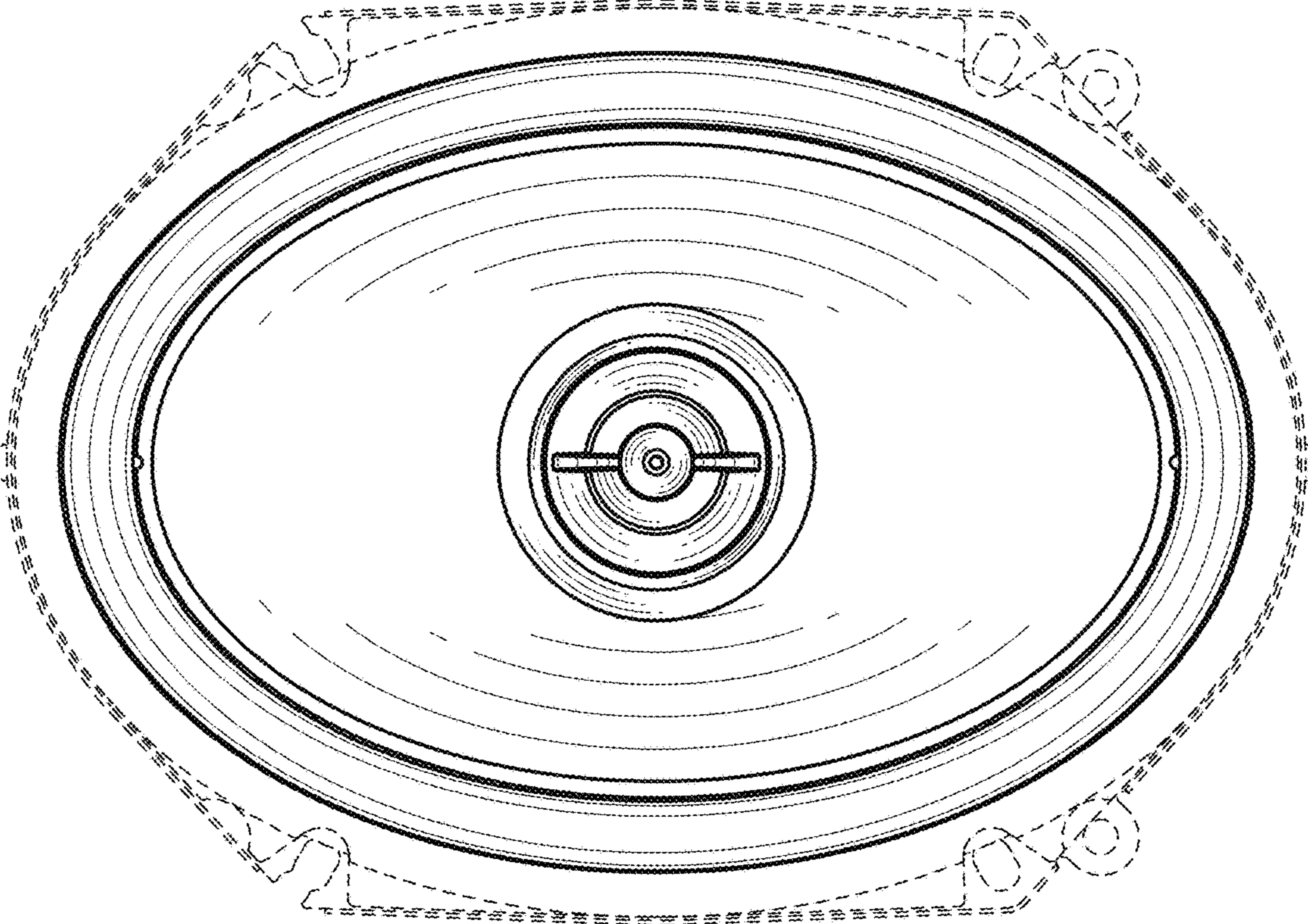

FIG. 2

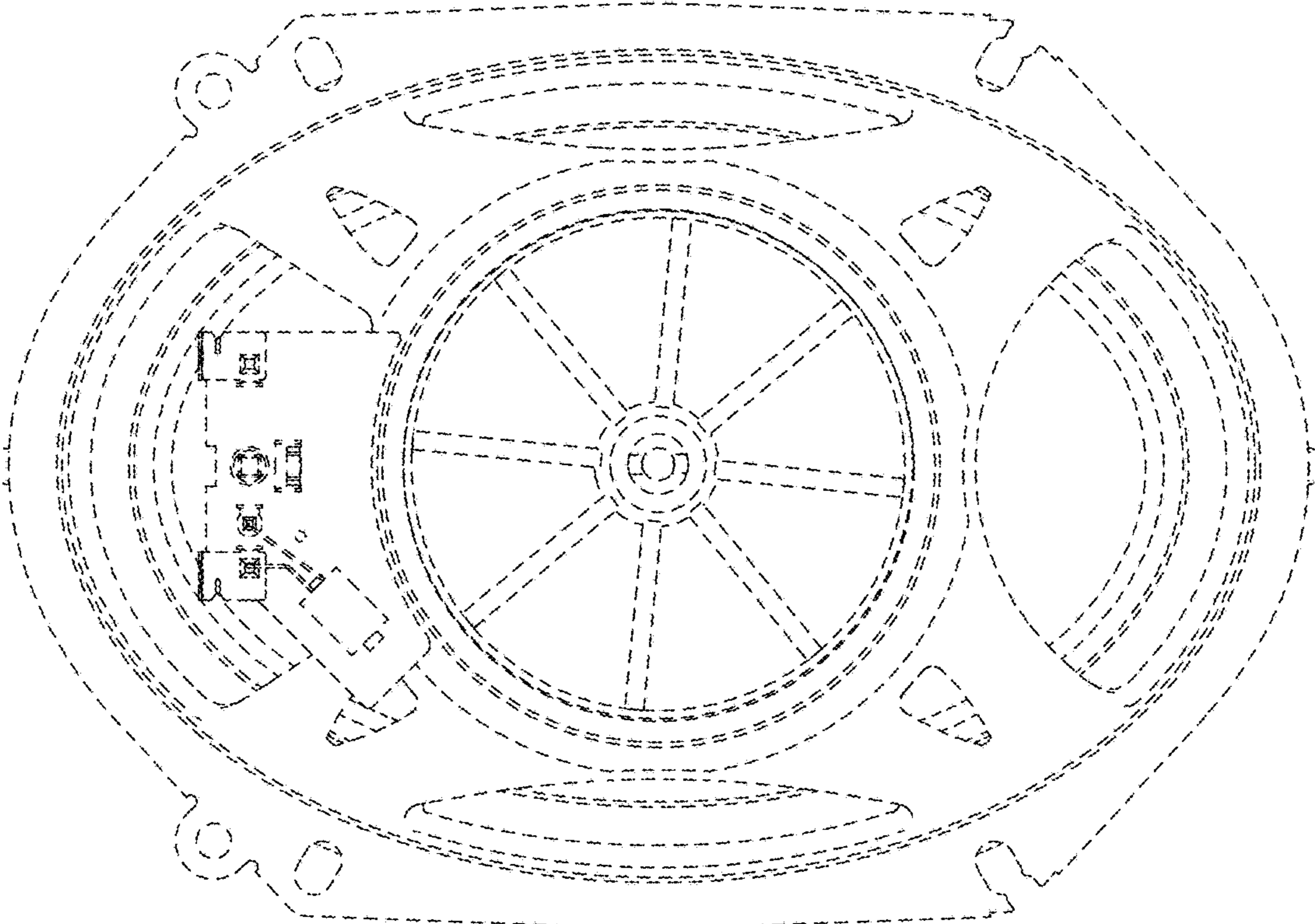

FIG. 3

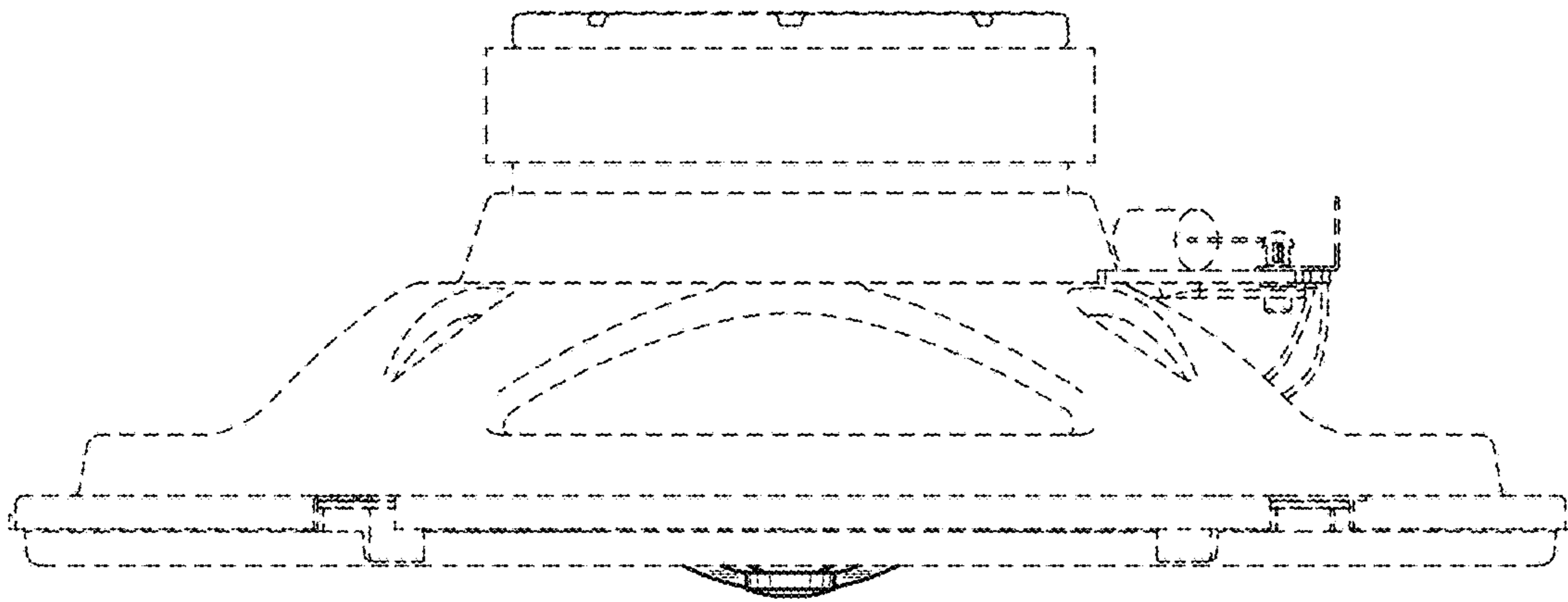

FIG. 4

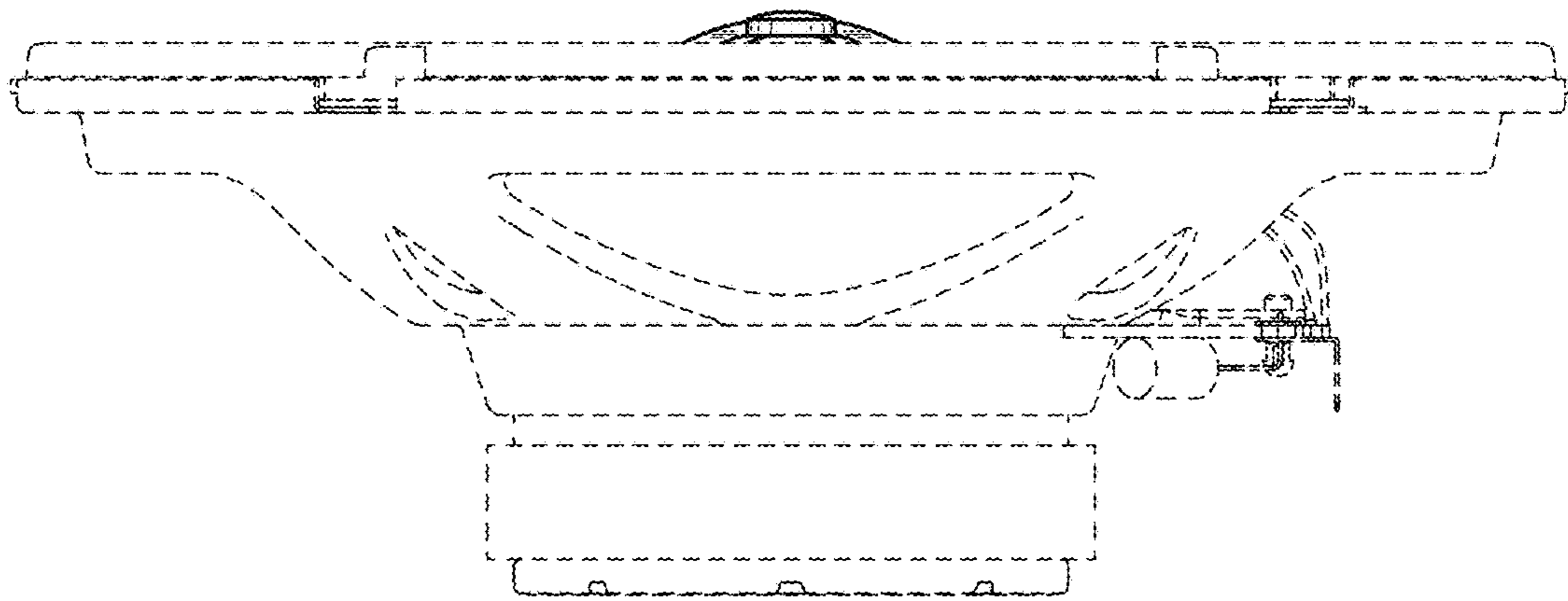

FIG. 5

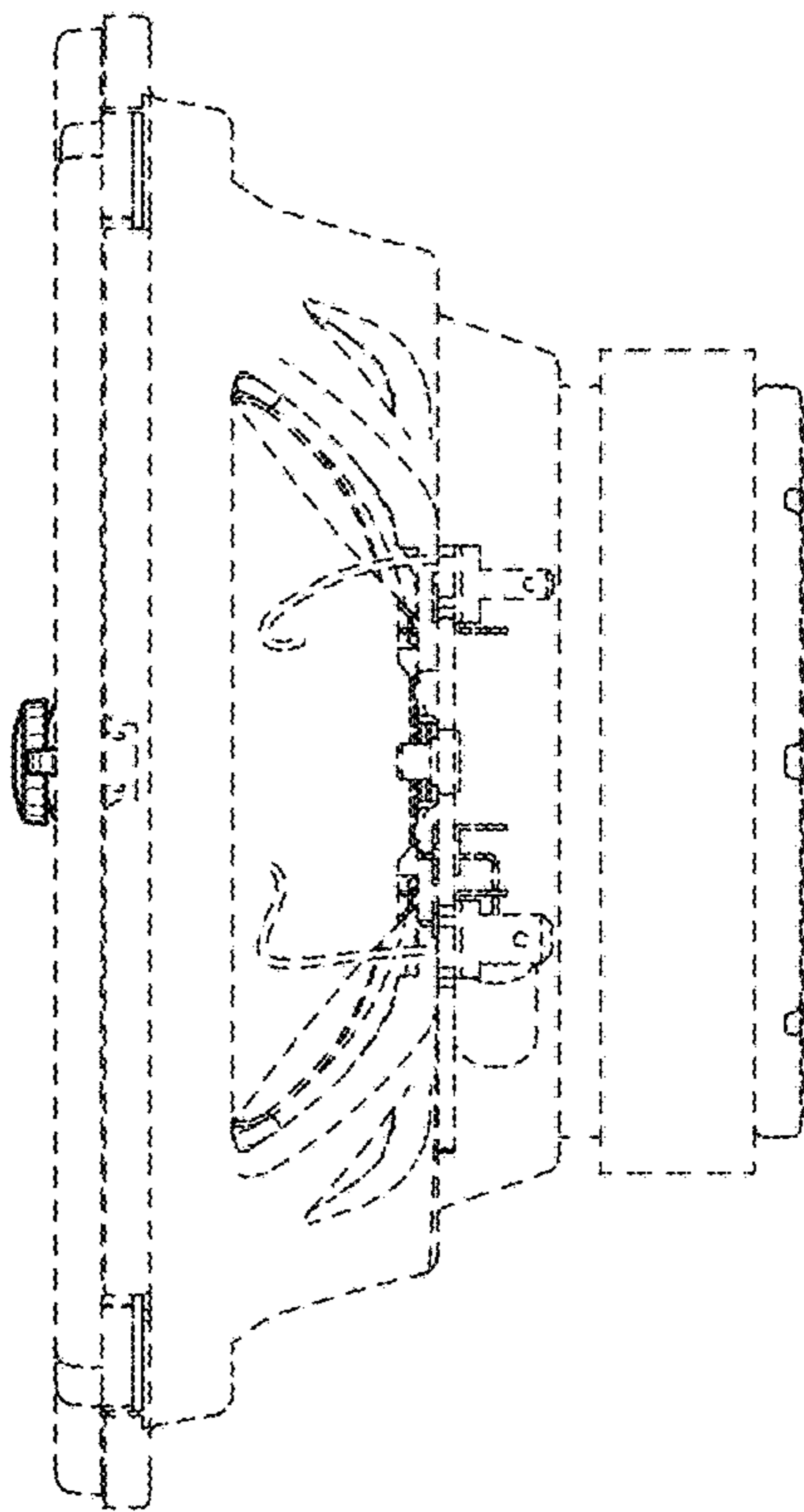

FIG. 6



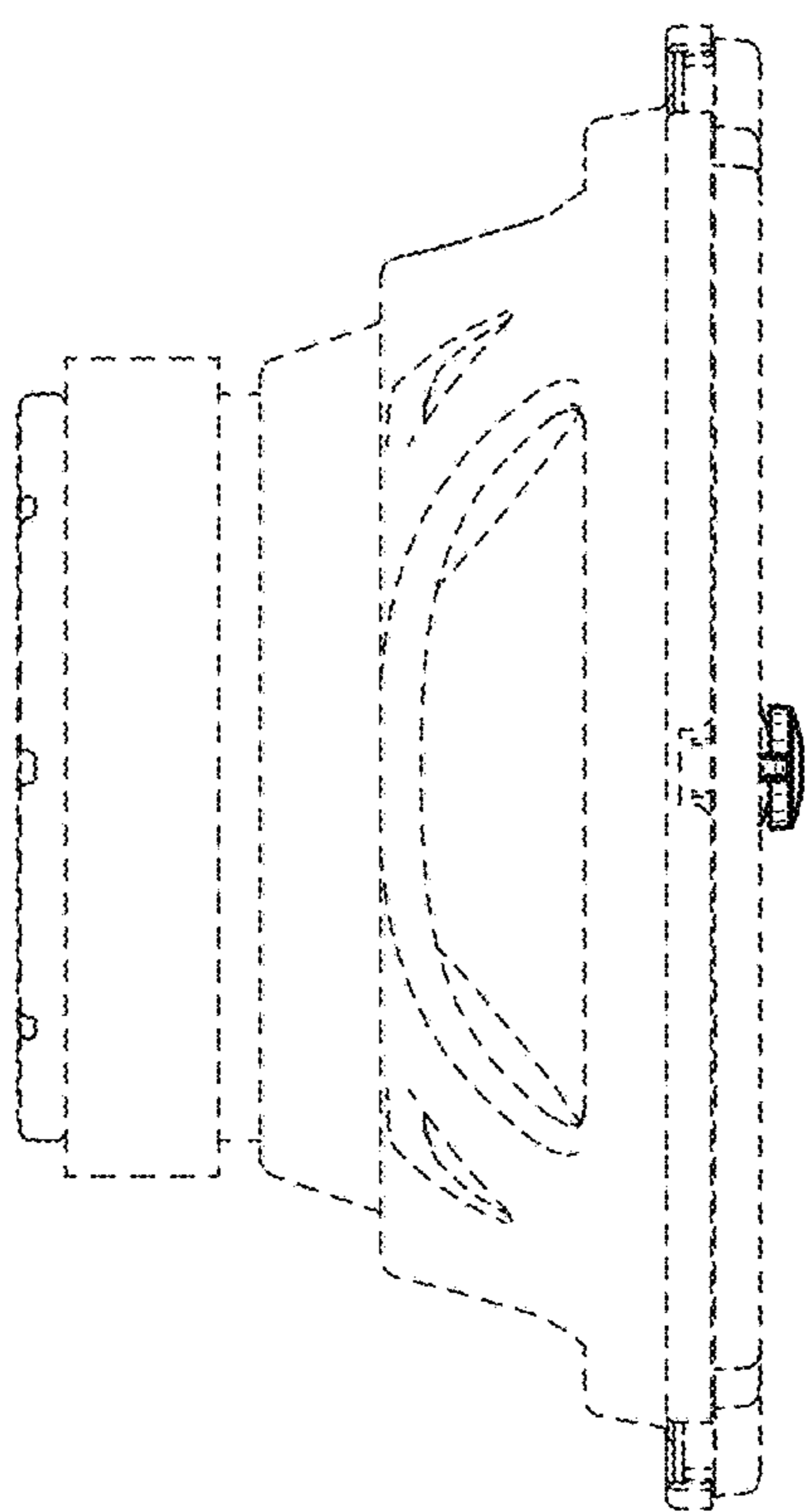

FIG. 7