



US00D859223S

(12) **United States Design Patent** (10) **Patent No.:** **US D859,223 S**
Weichers (45) **Date of Patent:** **** Sep. 10, 2019**

- (54) **SADDLE BAG PROTECTOR**
- (71) Applicant: **Steven Blair Weichers**, Escondido, CA (US)
- (72) Inventor: **Steven Blair Weichers**, Escondido, CA (US)
- (**) Term: **15 Years**
- (21) Appl. No.: **29/638,031**
- (22) Filed: **Feb. 23, 2018**
- (51) **LOC (12) Cl.** **12-11**
- (52) **U.S. Cl.**
USPC **D12/114**
- (58) **Field of Classification Search**
USPC D12/114, 110, 117, 119, 126, 407, 409, D12/410, 184, 186
CPC B62J 9/00; B62J 9/001; B62J 23/00; B62J 27/00
See application file for complete search history.

6,419,039	B1 *	7/2002	Wagner	B62J 27/00	180/219
D515,985	S *	2/2006	Kishi	D12/126	
D575,199	S *	8/2008	Stahel, Jr.	D12/114	
D608,262	S *	1/2010	Truebsbach	D12/190	
D715,697	S *	10/2014	Futamata	D12/114	
D751,948	S *	3/2016	Bloch	D10/109.1	
D803,105	S *	11/2017	Tsuji	D12/126	
D842,766	S *	3/2019	Greene	D12/114	

* cited by examiner

Primary Examiner — Michelle E. Wilson
Assistant Examiner — Clese Moore, Jr.
(74) *Attorney, Agent, or Firm* — Quickpatents, LLC; Kevin Prince

(57) **CLAIM**

I claim the ornamental design for a saddle bag protector, as shown and described.

DESCRIPTION

FIG. 1 is a perspective view of a saddle bag protector, showing my new design;
FIG. 2 is an enlarged front elevational view thereof;
FIG. 3 is an enlarged rear elevational view thereof;
FIG. 4 is a left-side elevational view thereof;
FIG. 5 is a right-side elevational view thereof;
FIG. 6 is a top plan view thereof; and,
FIG. 7 is a bottom plan view thereof.
The broken lines showing a motor cycle with saddle bags in FIG. 1 depict environmental matter and form no part of the claimed design.

1 Claim, 2 Drawing Sheets

(56) **References Cited**

U.S. PATENT DOCUMENTS

D374,295	S *	10/1996	Farchione	D12/114
D403,991	S *	1/1999	Davidson	D12/114
6,068,075	A *	5/2000	Saiki	B62J 9/00
					180/219
D442,121	S *	5/2001	LaBonte	D12/114
D442,122	S *	5/2001	LaBonte	D12/114
D460,388	S *	7/2002	Price	D12/114
D460,724	S *	7/2002	Owens	D12/114

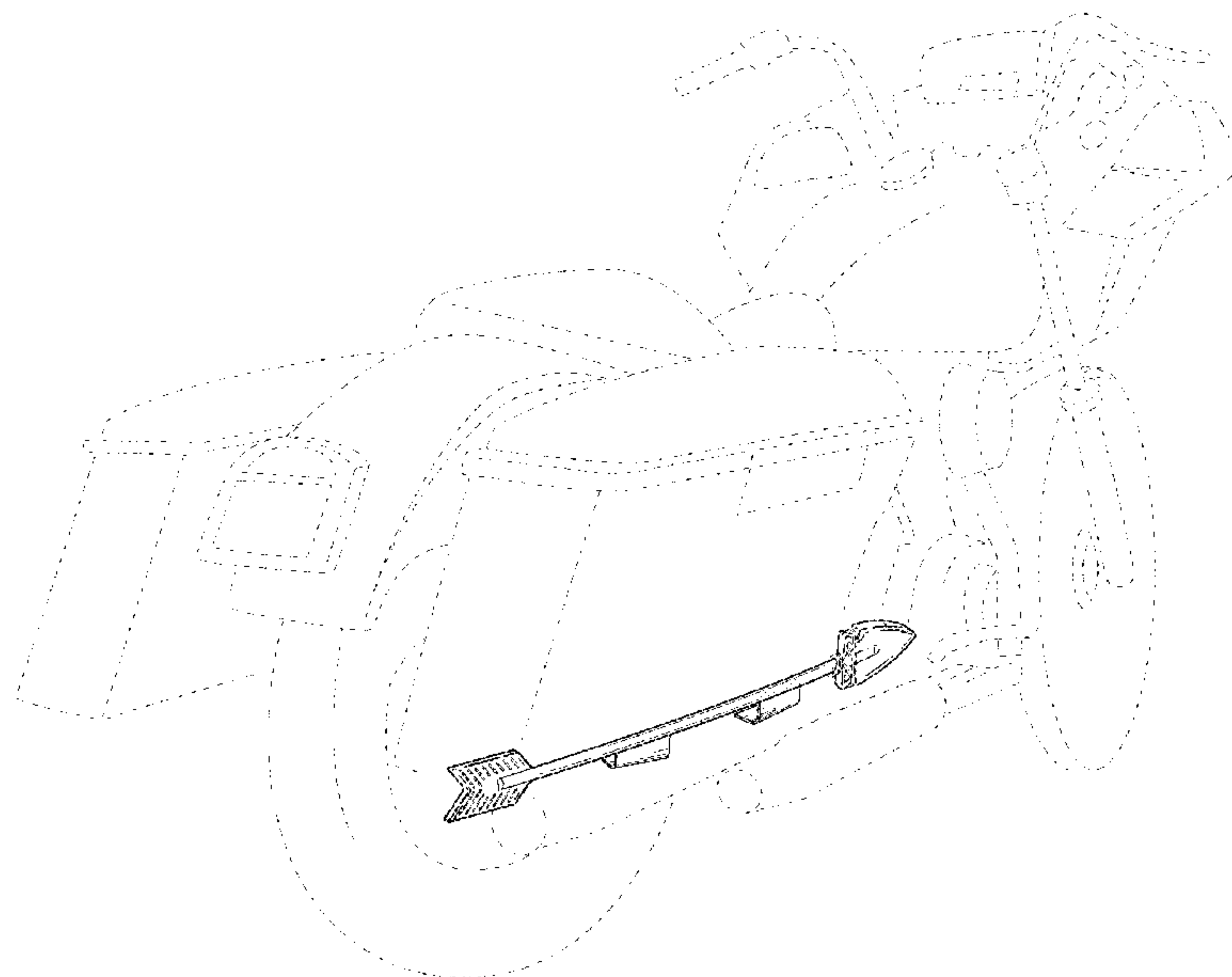

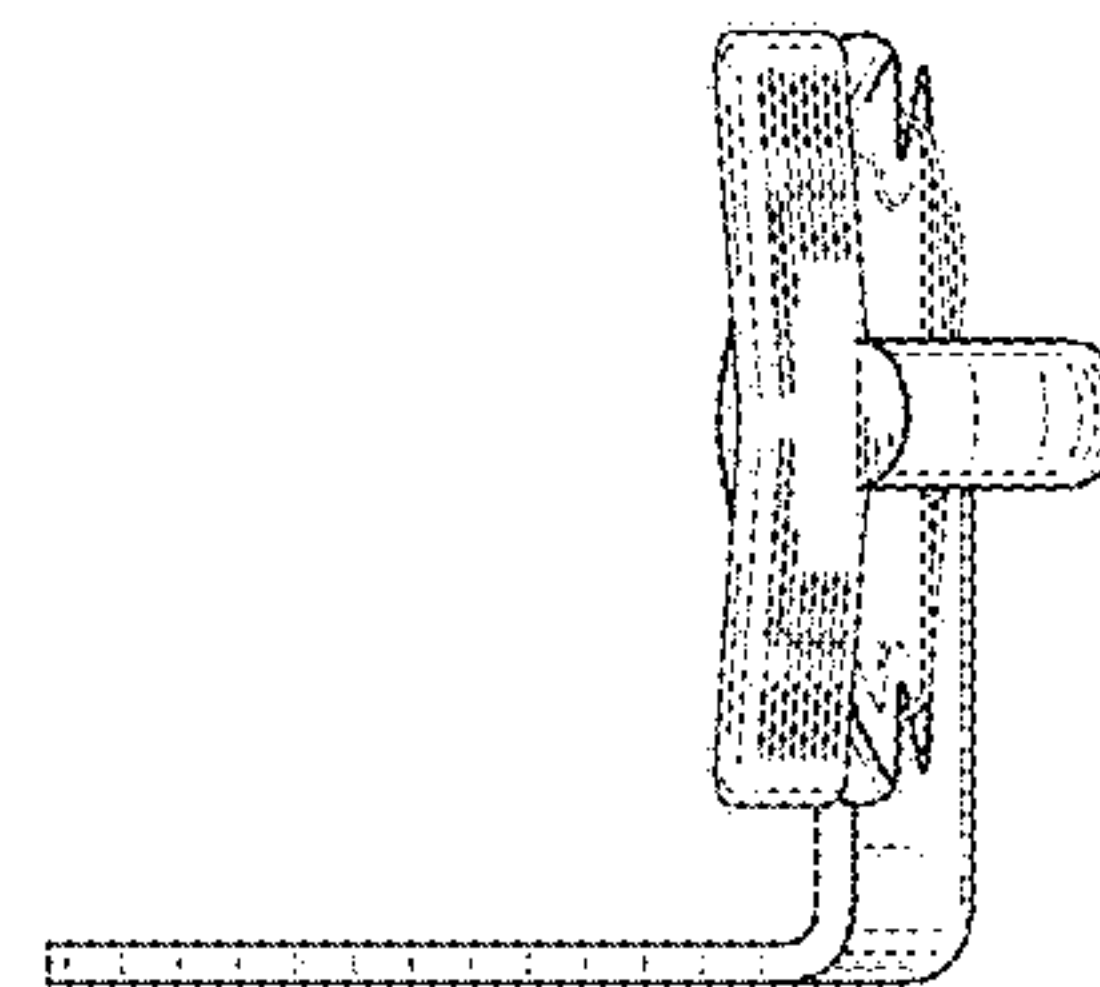
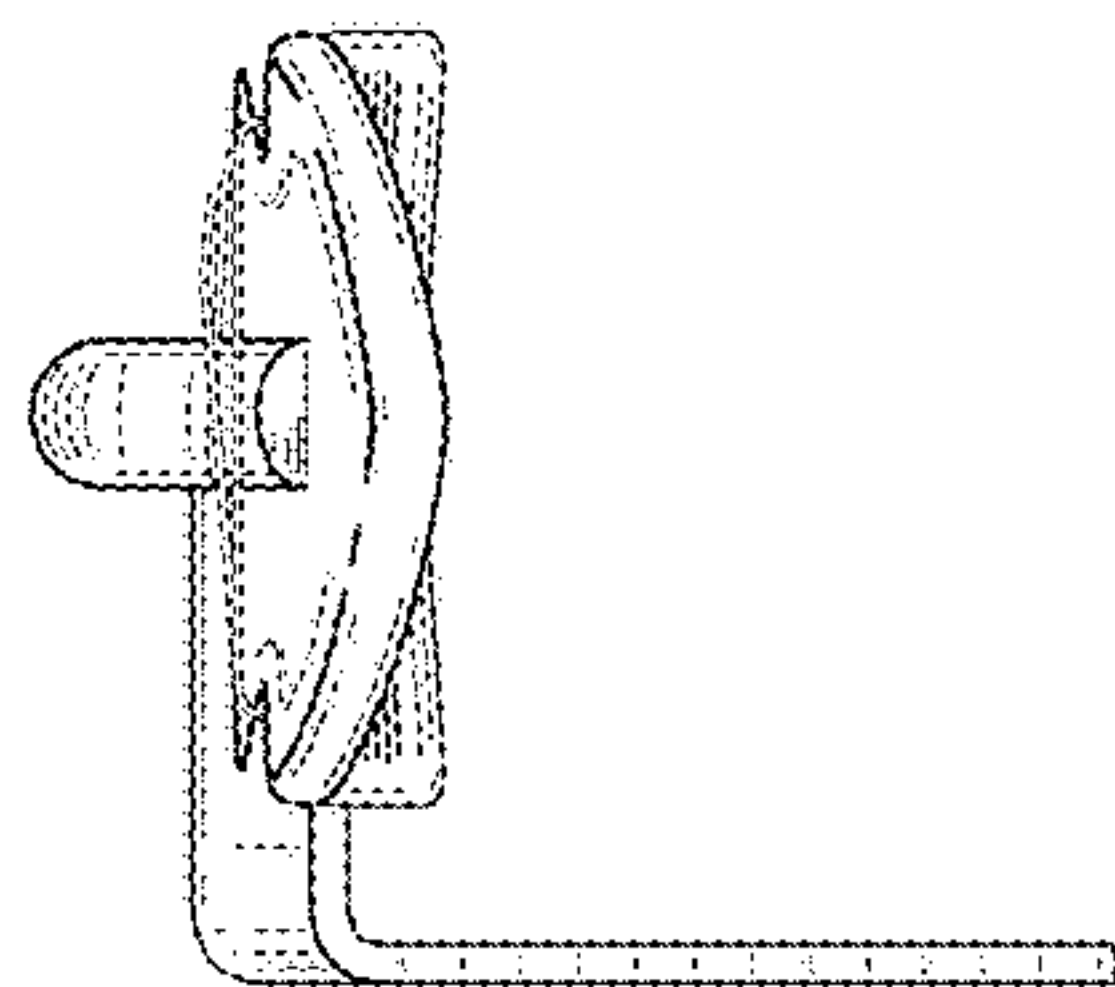
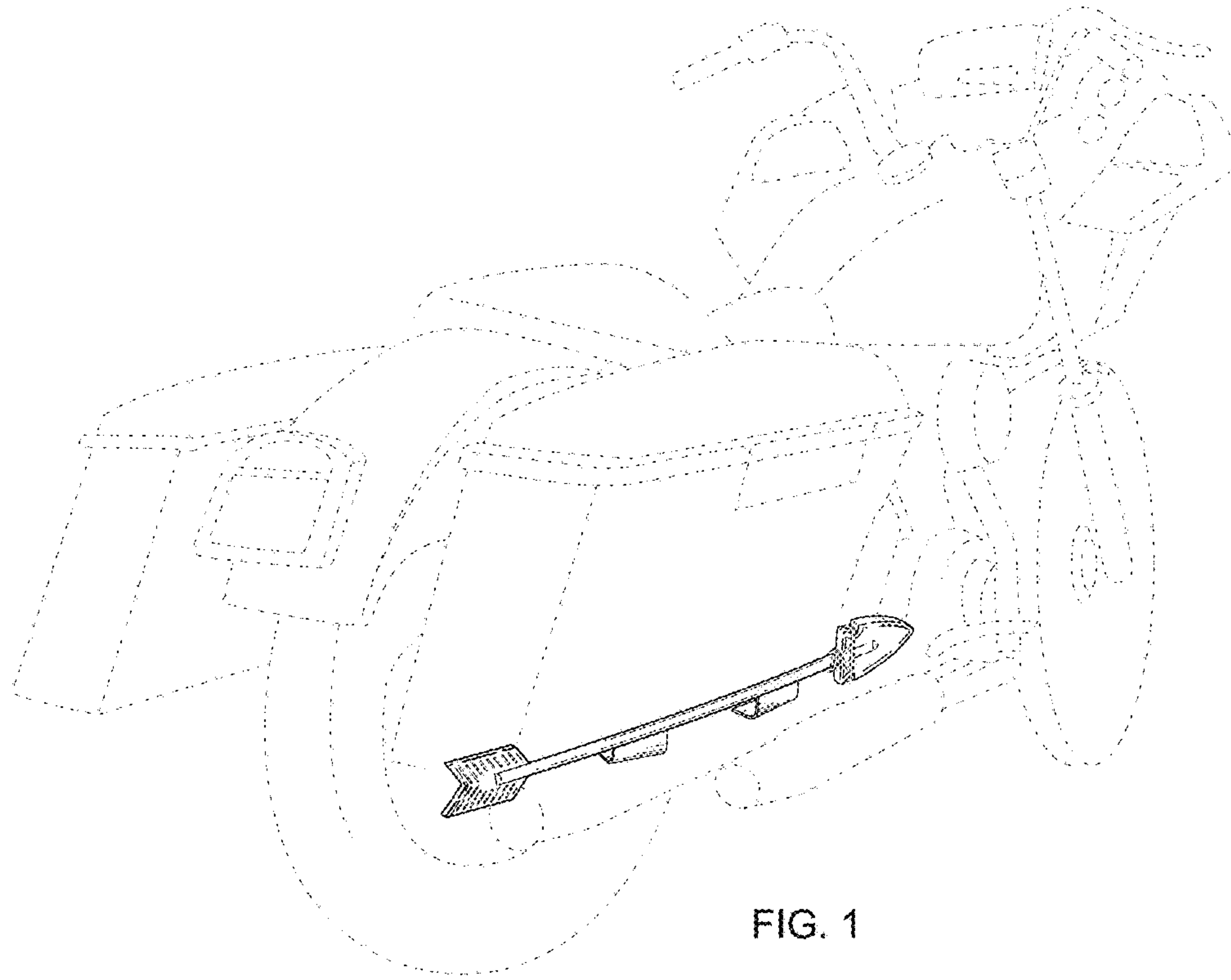

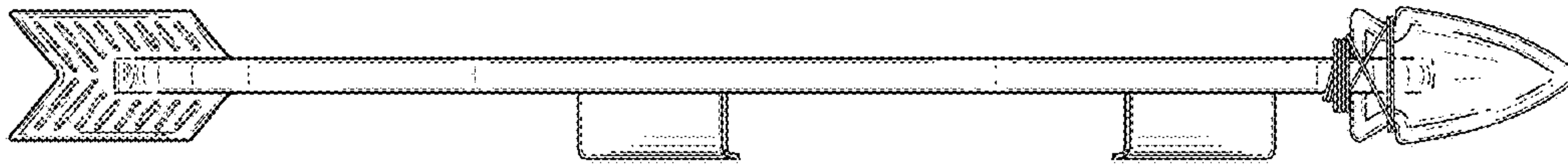

FIG. 4

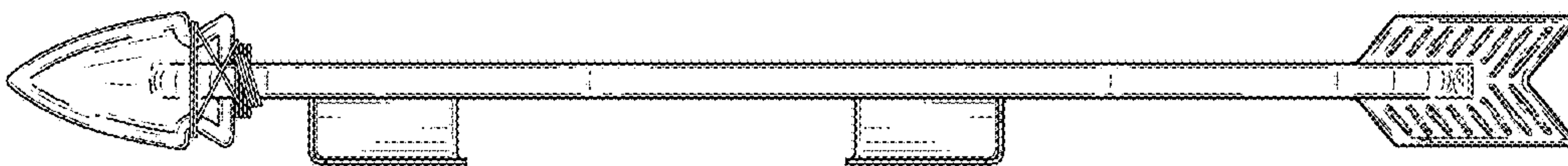

FIG. 5

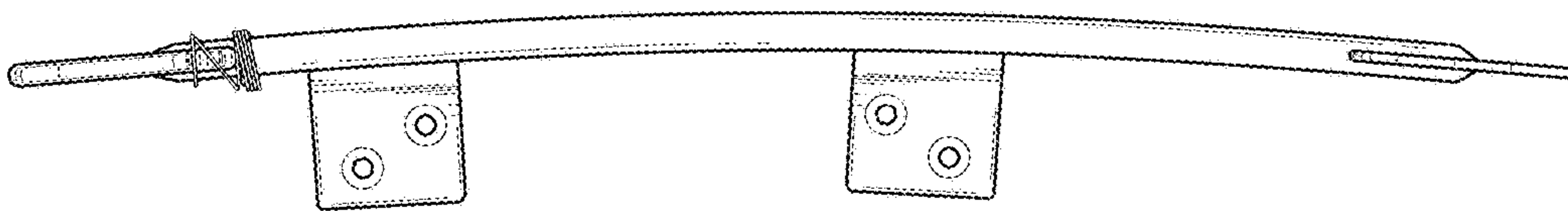

FIG. 6

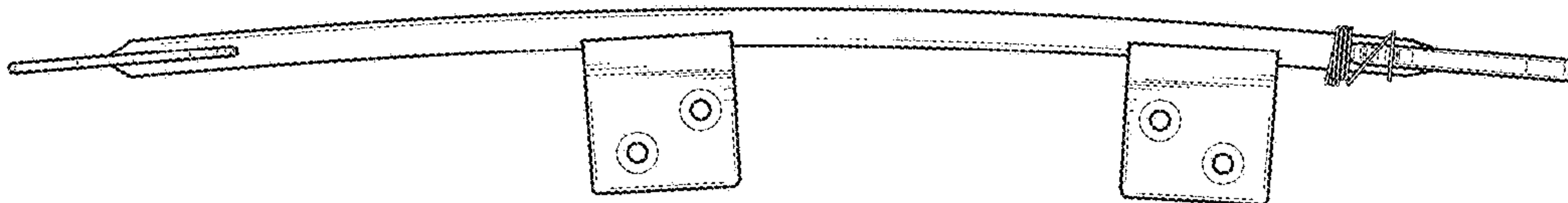

FIG. 7