



US00D859125S

(12) **United States Design Patent** (10) **Patent No.:** **US D859,125 S**
Weagle et al. (45) **Date of Patent:** **** Sep. 10, 2019**

(54) **CYCLE SUSPENSION REBOUND KNOB**
(71) Applicant: **TRVSTPER, INC.**, Salt Lake City, UT (US)
(72) Inventors: **David Weagle**, Edgartown, MA (US); **Michael Giese**, Salt Lake City, UT (US)
(73) Assignee: **TRVSTPER, INC.**, Salt Lake City, UT (US)

423,471 A 3/1890 Easthope
426,402 A 4/1890 Torkelson
435,477 A 9/1890 Blackledge
441,649 A 12/1890 Dunlop
443,266 A 12/1890 Bell
444,639 A 1/1891 O'Neill
(Continued)

(**) Term: **15 Years**

(21) Appl. No.: **29/636,527**
(22) Filed: **Feb. 8, 2018**
(51) **LOC (12) Cl.** **08-06**
(52) **U.S. Cl.**
USPC **D8/310**; D8/307; D12/118
(58) **Field of Classification Search**
USPC D8/300, 303, 307, 308, 309, 310, 311, D8/312, 313, 314, 321, 322, 349, 382, D8/387, 388, 391, 393, 394, 397, 399, D8/402, 499; D12/114, 118, 159, 160, D12/161, 197, 201-213, 223, 400; D9/453, 503; D15/5
CPC B62K 2025/041; B62K 2025/045; B62K 2025/048; B62K 2025/042; B62K 2025/044; B62K 2025/047; F16F 1/121; F16F 13/02; F16F 13/04; F16F 13/101; F16F 15/0275; F16F 15/1202; G05G 9/00; G05G 9/02
See application file for complete search history.

FOREIGN PATENT DOCUMENTS

BE 507753 A 12/1951
CA 474575 A 6/1951
(Continued)

OTHER PUBLICATIONS

Black and white photograph of Greeves trials machine, Applicant's internal files.
(Continued)

Primary Examiner — Darlington Ly
(74) *Attorney, Agent, or Firm* — Marshall, Gerstein & Borun LLP

(57) **CLAIM**

The ornamental design for a cycle suspension rebound knob, as shown and described.

DESCRIPTION

FIG. 1 is a top and front perspective view of a cycle suspension rebound knob showing our new design; FIG. 2 is a front elevation view thereof; FIG. 3 is a rear elevation view thereof; FIG. 4 is a right side elevation view thereof; FIG. 5 is a left side elevation view thereof; FIG. 6 is a top plan view thereof; and, FIG. 7 is a bottom plan view thereof. The broken lines in the drawings illustrate portions of the cycle suspension rebound knob that form no part of the claimed design.

1 Claim, 7 Drawing Sheets

(56) **References Cited**

U.S. PATENT DOCUMENTS

389,200 A 9/1888 Clegg
393,387 A 11/1888 Norton
400,727 A 4/1889 Baudreau
412,322 A 10/1889 Copeland
414,048 A 10/1889 Hunter

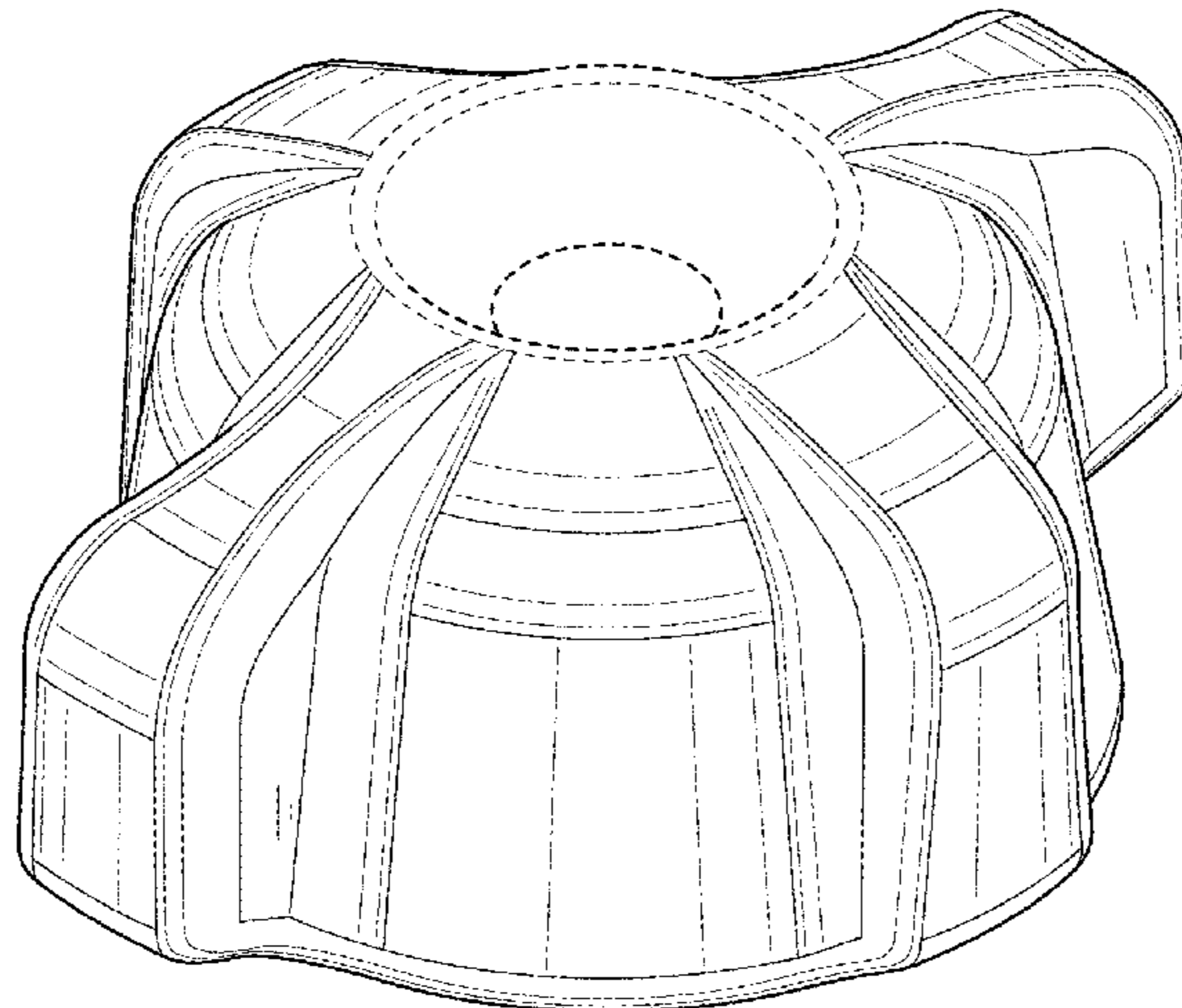

(56)

References Cited

U.S. PATENT DOCUMENTS

447,234 A	2/1891	Donnelly	2,660,455 A	11/1953	Douglas et al.
467,794 A	1/1892	Ellis	2,708,112 A	5/1955	Seddon et al.
468,643 A	2/1892	Clement	2,729,465 A	1/1956	Torre
524,389 A	8/1894	La Casse	2,751,991 A	6/1956	Mennesson
602,354 A	4/1898	Ohlgart	2,752,167 A	6/1956	Propst et al.
638,723 A	12/1899	Kelly	2,756,070 A	7/1956	Torre
739,476 A	9/1903	Becker	2,756,832 A	7/1956	Dalrymple
783,236 A	2/1905	Ashburn	2,918,306 A	12/1959	Lewandoski
848,324 A	3/1907	Sager	2,953,395 A	9/1960	Turner
913,961 A	3/1909	Levedahl	2,969,992 A	1/1961	Hahn
927,989 A	7/1909	Meiser	2,976,056 A	3/1961	Henry
940,245 A	11/1909	Gates	3,083,038 A	3/1963	Moulton
946,143 A	1/1910	Levedahl	3,133,748 A	5/1964	Gunnerson
953,697 A	4/1910	Kuebodeaux	3,433,318 A	3/1969	Packard
973,071 A	10/1910	Redmond	3,694,004 A	9/1972	Siebers
979,674 A	12/1910	Kittle et al.	3,701,544 A	10/1972	Stankovich
980,999 A	1/1911	Pommer	3,730,553 A	5/1973	Harman
989,638 A	4/1911	Pilgrim	3,774,935 A	11/1973	Aldrich
1,000,115 A	8/1911	Oquist	3,942,821 A	3/1976	Bock
1,036,263 A	8/1912	Kittle	3,944,254 A	3/1976	Inui
1,042,480 A	10/1912	Ridgway	3,954,284 A	5/1976	Phillips et al.
1,077,105 A	10/1913	Stewart	3,989,261 A	11/1976	Kawaguchi
1,096,417 A	5/1914	Ekstrom	4,057,264 A	11/1977	Suzuki et al.
1,101,614 A	6/1914	Bramham	4,147,371 A	4/1979	Morita et al.
1,132,829 A	3/1915	Cobb	4,153,237 A	5/1979	Supalla
1,144,753 A	6/1915	Budroe	4,159,123 A	6/1979	Petty
1,166,156 A	12/1915	Shimmin	4,162,797 A	7/1979	McBride
1,189,874 A	7/1916	Schickel	4,170,369 A	10/1979	Strutman
1,203,927 A	11/1916	Stagni	4,179,135 A	12/1979	Slater
1,213,995 A	1/1917	Anderson	4,180,280 A	12/1979	Doveri
1,223,572 A	4/1917	Drew	4,184,695 A	1/1980	Roe et al.
1,227,634 A	5/1917	Lake	4,186,936 A	2/1980	Offenstadt et al.
1,251,992 A	1/1918	Drew	4,189,168 A	2/1980	Courtney
1,254,798 A	1/1918	Harley	4,212,481 A	7/1980	Ribi
1,273,179 A	7/1918	Perry et al.	4,265,329 A	5/1981	de Cortanze
1,298,958 A	4/1919	Johnston	4,268,055 A	5/1981	Bell
1,333,449 A	3/1920	Russell	4,295,658 A	10/1981	Kashima
1,365,524 A	1/1921	Mellantine	4,367,882 A	1/1983	Alexander et al.
1,397,850 A	11/1921	Yoxall et al.	4,388,978 A	6/1983	Fior
1,432,376 A	10/1922	Wolff	4,401,316 A	8/1983	Miyakoshi et al.
1,452,436 A	4/1923	Pullin	4,406,475 A	9/1983	Miyakoshi et al.
1,475,044 A	11/1923	Bloom	4,410,196 A	10/1983	Ribi
1,517,146 A	11/1924	Bloom	4,421,337 A	12/1983	Pratt
1,527,133 A	2/1925	Harley	4,422,662 A	12/1983	Inoue et al.
1,605,680 A	11/1926	Merkel	4,433,850 A	2/1984	Miyakoshi et al.
1,834,308 A	12/1931	Harley	4,433,851 A	2/1984	Miyakoshi et al.
1,924,363 A	8/1933	Kanai	4,437,678 A	3/1984	Schultz
2,038,011 A	4/1936	Spiegler et al.	4,438,909 A	3/1984	Matsumoto
D101,826 S *	11/1936	Sinko D12/179	4,444,406 A	4/1984	Isono
2,073,736 A	3/1937	Duffy	4,455,032 A	6/1984	Kajikawa
2,087,299 A	7/1937	Pribil	4,480,711 A	11/1984	Satoh et al.
2,160,034 A	5/1939	Schwinn	4,520,892 A	6/1985	Satoh
2,203,342 A	6/1940	Sloman	4,526,249 A	7/1985	Parker
2,233,313 A	2/1941	Hazelroth	4,531,755 A	7/1985	Isono et al.
2,271,304 A	1/1942	Mulholland	4,533,153 A	8/1985	Tsunoda et al.
2,303,568 A	12/1942	McWhorter et al.	4,540,190 A	9/1985	Moulton
2,376,788 A	5/1945	Latscher-Latka	4,542,910 A	9/1985	Watanabe
2,462,711 A	2/1949	Barnett	4,561,669 A	12/1985	Simons
2,463,310 A	3/1949	Probst	4,570,963 A	2/1986	Isono
2,464,326 A	3/1949	MacGregor	4,572,534 A	2/1986	Heyl
2,475,774 A	7/1949	Benson	4,576,393 A	3/1986	Moulton et al.
2,485,484 A	10/1949	Dean	4,585,245 A	4/1986	Rose
2,486,430 A	11/1949	Moore	4,616,810 A	10/1986	Richardson et al.
2,489,821 A	11/1949	Ryder	4,625,985 A	12/1986	Nakano et al.
2,504,452 A	4/1950	Rostan	4,650,027 A	3/1987	de Cortanze
2,525,171 A	10/1950	Franks	4,660,683 A	4/1987	Hayashi et al.
2,537,679 A	1/1951	Kraeft	4,685,694 A	8/1987	Kouyama
2,540,585 A	2/1951	Kranz	4,702,338 A	10/1987	Trema
2,543,991 A	3/1951	Schuricht	4,703,839 A	11/1987	Yasuo et al.
2,550,876 A	5/1951	Spencer	4,723,621 A	2/1988	Kawano et al.
2,561,156 A	7/1951	Thorkildsen	4,732,241 A	3/1988	Yoshida
2,588,889 A	3/1952	Sherwood	4,738,468 A	4/1988	Baron
2,596,411 A	5/1952	Jordan	4,741,545 A	5/1988	Honma et al.
2,636,567 A	4/1953	Landrum	4,742,884 A	5/1988	Ishikawa
2,649,312 A	8/1953	Miller	4,744,434 A	5/1988	Miyakoshi et al.
			4,770,434 A	9/1988	Pietro et al.
			4,775,163 A	10/1988	McGowan et al.
			4,776,609 A	10/1988	Pan et al.
			4,789,174 A	12/1988	Lawwill

(56)

References Cited

U.S. PATENT DOCUMENTS

4,807,898 A 2/1989 Huntly
 4,809,802 A 3/1989 Seino et al.
 4,815,763 A 3/1989 Hartmann
 4,828,069 A 5/1989 Hatsuyama
 4,834,412 A 5/1989 Trema
 4,878,558 A 11/1989 Asakura
 4,881,750 A 11/1989 Hartmann
 4,890,857 A 1/1990 de Cortanze
 4,971,344 A 11/1990 Turner
 4,993,734 A 2/1991 Trema
 4,997,197 A 3/1991 Shultz
 5,009,451 A 4/1991 Hayashi et al.
 5,042,608 A 8/1991 Horiike et al.
 5,050,699 A 9/1991 Savard
 5,064,212 A 11/1991 Yun
 5,069,303 A 12/1991 Fuller
 5,069,467 A 12/1991 Claudio
 5,088,705 A 2/1992 Tsai
 5,133,223 A 7/1992 Morri
 5,156,231 A 10/1992 Trema
 5,186,481 A 2/1993 Turner
 5,193,832 A 3/1993 Wilson et al.
 5,193,833 A 3/1993 Reisinger
 5,195,766 A 3/1993 Dohrmann et al.
 5,219,211 A 6/1993 Tsuchida et al.
 5,248,159 A 9/1993 Moore
 5,249,650 A 10/1993 Tanaka
 5,269,549 A 12/1993 Wilson et al.
 5,284,352 A 2/1994 Chen
 5,299,820 A 4/1994 Lawwill
 5,308,099 A 5/1994 Browning
 5,310,203 A 5/1994 Chen
 5,320,374 A 6/1994 Farris et al.
 5,328,196 A 7/1994 Ohma
 5,350,185 A 9/1994 Robinson
 5,354,085 A 10/1994 Gally
 5,359,910 A 11/1994 Chang et al.
 5,361,864 A 11/1994 Tanaka
 5,380,026 A 1/1995 Robinson
 5,403,028 A 4/1995 Trimble
 5,405,159 A 4/1995 Klein et al.
 5,409,248 A 4/1995 Williams
 5,413,368 A 5/1995 Pong et al.
 5,417,446 A 5/1995 Pileggi
 5,427,208 A 6/1995 Motobu et al.
 5,427,397 A 6/1995 Chonan
 5,429,380 A 7/1995 Lawwill
 5,431,426 A 7/1995 Ijams et al.
 5,441,291 A 8/1995 Girvin, III
 5,449,155 A 9/1995 Mack
 5,456,480 A 10/1995 Turner et al.
 5,462,302 A 10/1995 Leitner
 5,498,013 A 3/1996 Hwang
 5,509,674 A 4/1996 Browning
 5,509,676 A 4/1996 Fukutake et al.
 5,564,534 A 10/1996 Toyota et al.
 5,599,034 A 2/1997 Brigden
 5,743,547 A 4/1998 Voss et al.
 5,749,590 A 5/1998 Roerig
 5,782,313 A 7/1998 Kurawaki et al.
 5,799,963 A 9/1998 Berkman
 5,813,684 A 9/1998 Baron
 5,829,773 A 11/1998 Rajae
 5,855,388 A 1/1999 Brewer
 5,899,478 A 5/1999 Woodside
 5,908,200 A 6/1999 Stewart
 5,931,487 A 8/1999 Koppelberg et al.
 5,931,489 A 8/1999 Damman et al.
 6,017,047 A 1/2000 Hoose
 6,036,211 A 3/2000 Nohr
 6,047,981 A 4/2000 Burrows
 6,089,585 A 7/2000 Theobald
 6,149,173 A 11/2000 Bynoe
 6,152,472 A 11/2000 Woodside
 6,155,370 A 12/2000 Iwai et al.

6,164,424 A 12/2000 Girvin et al.
 6,164,675 A 12/2000 Pickering
 6,199,885 B1 3/2001 Seidl
 6,244,609 B1 6/2001 Wilson
 6,260,869 B1 7/2001 Hanlon et al.
 6,260,870 B1 7/2001 Fan
 6,263,994 B1 7/2001 Eitel
 D451,361 S * 12/2001 Yang D8/307
 6,336,647 B1 1/2002 Iwai et al.
 6,357,775 B1 3/2002 Iwai et al.
 6,371,263 B1 4/2002 Hoose
 6,382,374 B1 5/2002 Iwai et al.
 6,386,567 B1 5/2002 Schonfeld
 6,402,175 B1 6/2002 Jansson
 6,457,732 B2 10/2002 Ito et al.
 6,485,043 B2 11/2002 Ito et al.
 6,488,300 B2 12/2002 Ito et al.
 6,517,095 B1 2/2003 Lansac et al.
 6,517,096 B2 2/2003 Yih
 6,533,305 B1 3/2003 Falk
 D472,947 S * 4/2003 Wu D21/694
 6,783,140 B1 8/2004 Huang
 6,789,810 B2 9/2004 Strong
 6,896,276 B1 5/2005 Sparrow
 6,908,092 B2 6/2005 Kofuji et al.
 6,910,702 B1 6/2005 Hals
 6,918,605 B2 7/2005 Wada et al.
 6,994,365 B2 2/2006 Kofuji
 7,011,325 B2 3/2006 Kinzler et al.
 7,140,627 B2 11/2006 Wimmer
 7,159,883 B2 1/2007 Mydlarz
 7,210,695 B2 5/2007 Griffiths
 7,331,594 B2 2/2008 Wimmer
 7,350,787 B2 4/2008 Voss
 7,364,178 B2 4/2008 Wimmer
 D572,998 S * 7/2008 Crain D8/305
 7,425,008 B2 9/2008 Pokrywka
 7,425,009 B2 9/2008 Namazue et al.
 7,434,823 B2 10/2008 Robinson et al.
 7,441,622 B2 10/2008 Costa
 7,699,330 B2 4/2010 Chen
 7,708,296 B2 5/2010 Becker et al.
 7,744,107 B2 6/2010 Chen
 7,887,077 B2 2/2011 Thiers
 7,896,379 B2 3/2011 Nagao et al.
 7,963,003 B1 * 6/2011 Keene F24C 15/086
 16/441
 8,448,970 B1 5/2013 Vardon
 8,534,692 B2 9/2013 Trebichavsky
 8,939,458 B2 1/2015 Nesbitt, III
 9,248,883 B2 2/2016 D'Aluisio
 D796,293 S * 9/2017 Alliss D8/310
 D803,137 S * 11/2017 Platto D12/213
 D813,639 S * 3/2018 Osanai D8/307
 D813,640 S * 3/2018 Osanai D8/310
 D813,641 S * 3/2018 Osanai D8/310
 D822,082 S * 7/2018 Tanimura D15/143
 10,036,443 B2 * 7/2018 Galasso B62K 25/04
 D827,042 S * 8/2018 Weissman D21/455
 D838,169 S * 1/2019 Holmes D9/443
 2001/0019197 A1 9/2001 Ito et al.
 2002/0084619 A1 7/2002 Odom
 2004/0036250 A1 2/2004 Kofuji
 2005/0283049 A1 * 12/2005 Seki A61B 1/0011
 600/147
 2008/0258424 A1 10/2008 Paul
 2009/0065316 A1 * 3/2009 Chen B62K 25/08
 188/322.14
 2011/0012321 A1 1/2011 Chen
 2012/0228906 A1 * 9/2012 McAndrews B62J 1/08
 297/215.13
 2016/0167730 A1 * 6/2016 Lozac'h B62K 25/08
 267/286

FOREIGN PATENT DOCUMENTS

CH 63758 A 2/1914
 DE 1084599 B 6/1960

(56)

References Cited

FOREIGN PATENT DOCUMENTS

DE 1122392 B 1/1962
 DE 3133576 A1 5/1983
 DE 3223728 A1 12/1983
 DE 8906328 U1 11/1989
 DE 3833880 A1 4/1990
 DE 4119339 A1 1/1992
 DE 9404873 U1 5/1994
 DE 9403640 U1 6/1994
 DE 9414705 U1 2/1995
 DE 19503047 A1 8/1996
 DE 19635939 A1 6/1997
 DE 19633692 A1 2/1998
 DK 49600 C 12/1934
 EP 0032170 B1 2/1986
 EP 0030306 B1 4/1986
 EP 0125244 B1 1/1987
 EP 0399615 A2 11/1990
 EP 420610 B1 2/1996
 EP 726198 A2 8/1996
 EP 0731017 B1 10/1997
 EP 0941916 A1 9/1999
 EP 0992374 A1 4/2000
 EP 1049618 B1 9/2003
 EP 728093 B2 11/2005
 EP 2096024 A1 9/2009
 EP 2100807 A1 9/2009
 EP 2357098 A2 8/2011
 EP 2483141 B1 11/2013
 FR 347724 A 3/1905
 FR 353990 A 9/1905
 FR 350269 A 12/1905
 FR 376759 A 8/1907
 FR 467213 A 6/1914
 FR 547006 A 11/1922
 FR 559088 A 9/1923
 FR 28240 E 1/1925
 FR 636211 A 4/1928
 FR 902973 A 9/1945
 FR 972653 A 2/1951
 FR 1030006 A 6/1953
 FR 1032268 A 6/1953
 FR 1059922 A 3/1954
 FR 1064265 A 5/1954
 FR 1067221 A 6/1954
 FR 1082316 A 12/1954
 FR 2418742 A1 9/1979
 FR 2494208 A2 5/1982
 FR 2687976 A1 9/1993
 FR 2687976 B1 5/1994
 FR 3004415 A1 10/2014
 GB 166065 A 7/1921

GB 223638 A 10/1924
 GB 238069 A 8/1925
 GB 239848 A 12/1925
 GB 258141 A 9/1926
 GB 264003 A 1/1927
 GB 279630 A 11/1927
 GB 302026 A 12/1928
 GB 322370 A 12/1929
 GB 469697 A 7/1937
 GB 585122 A 1/1947
 GB 585904 A 2/1947
 GB 586372 A 3/1947
 GB 691551 A 5/1953
 GB 717259 A 10/1954
 GB 720093 A 12/1954
 GB 824866 A 12/1959
 GB 841523 A 7/1960
 GB 1540824 A 2/1979
 GB 1545403 A 5/1979
 GB 2038736 A 7/1980
 GB 2052407 A 1/1981
 GB 2073680 A 10/1981
 GB 2106843 A 4/1983
 JP 63-112191 U 7/1988
 JP 649887 U 1/1989
 JP 1204884 A 8/1989
 JP 5069875 A 3/1993
 JP 05-020635 Y2 5/1993
 JP 1999091671 A 4/1999
 JP 2000159170 A 6/2000
 JP 2000159171 A 6/2000
 JP 2000159177 A 6/2000
 JP 2000159178 A 6/2000
 JP 2000168666 A 6/2000
 WO WO-82/00445 A1 2/1982
 WO WO-84/00526 A1 2/1984
 WO WO-87/01670 A1 3/1987
 WO WO-95/23728 A1 9/1995
 WO WO-97/46443 A1 12/1997
 WO WO-00/013961 A1 3/2000

OTHER PUBLICATIONS

Black and white photograph of Scorpion motorcycle, Applicant's internal files.
 Black and white photograph of Silencer motorcycle, Applicant's internal files.
 Color Photograph of a Cotton TC-70 motorcycle, Applicant's internal files.
 Color photograph of Armstrong bicycle, Applicant's Internal Files.
 Color photograph of Armstrong motor cycle, Applicant's internal files.

* cited by examiner

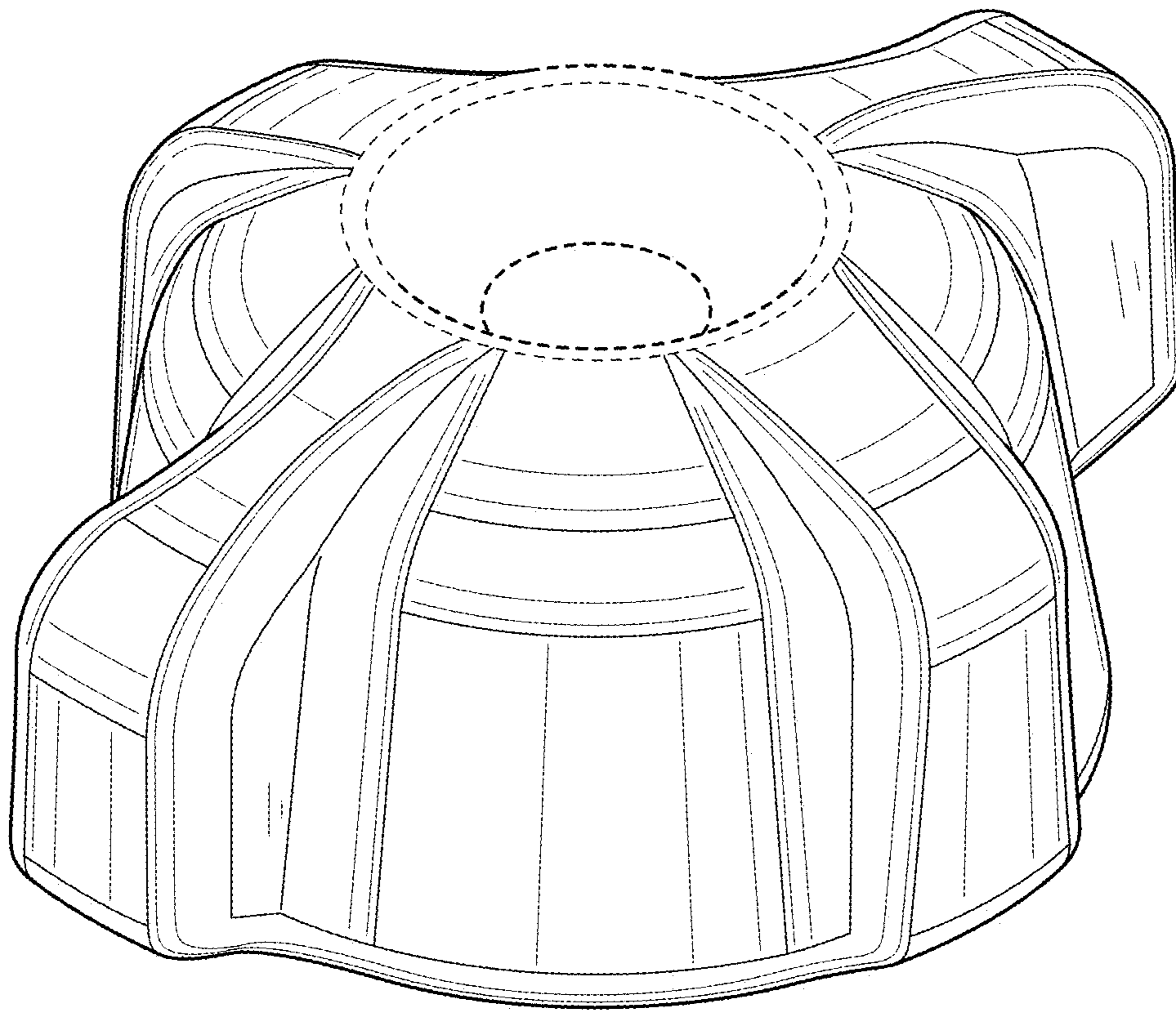

FIG. 1

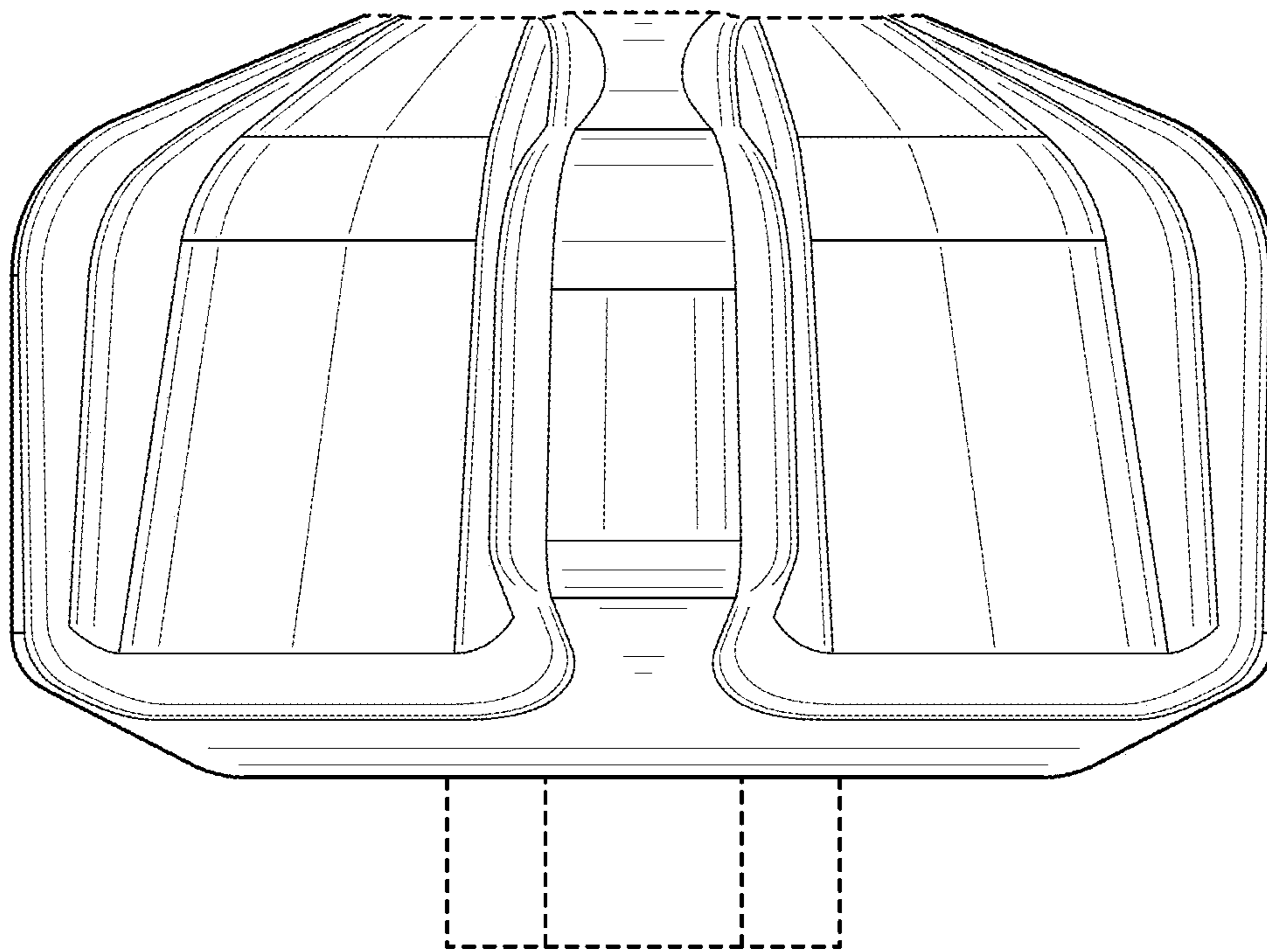

FIG. 2

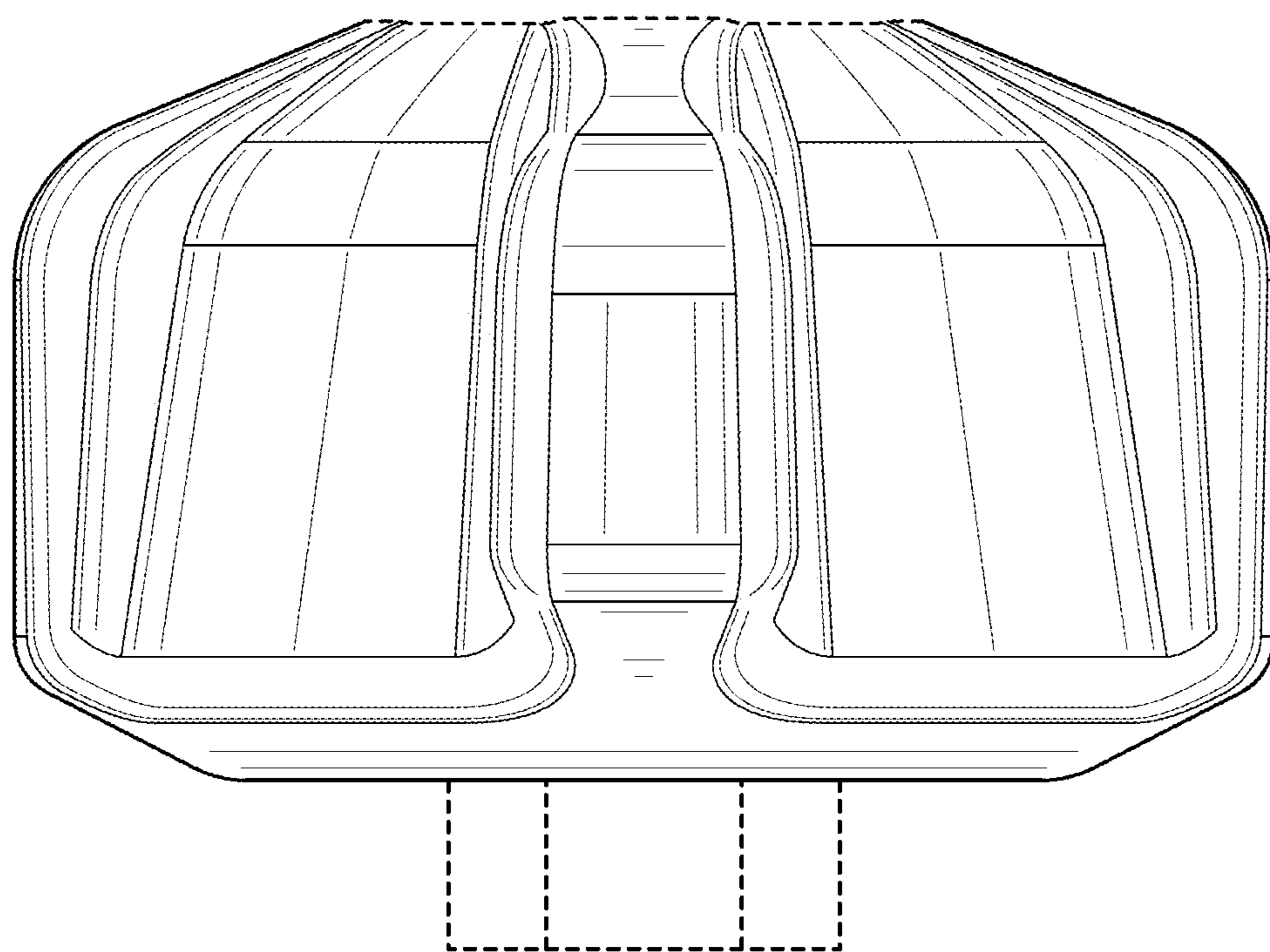

FIG. 3

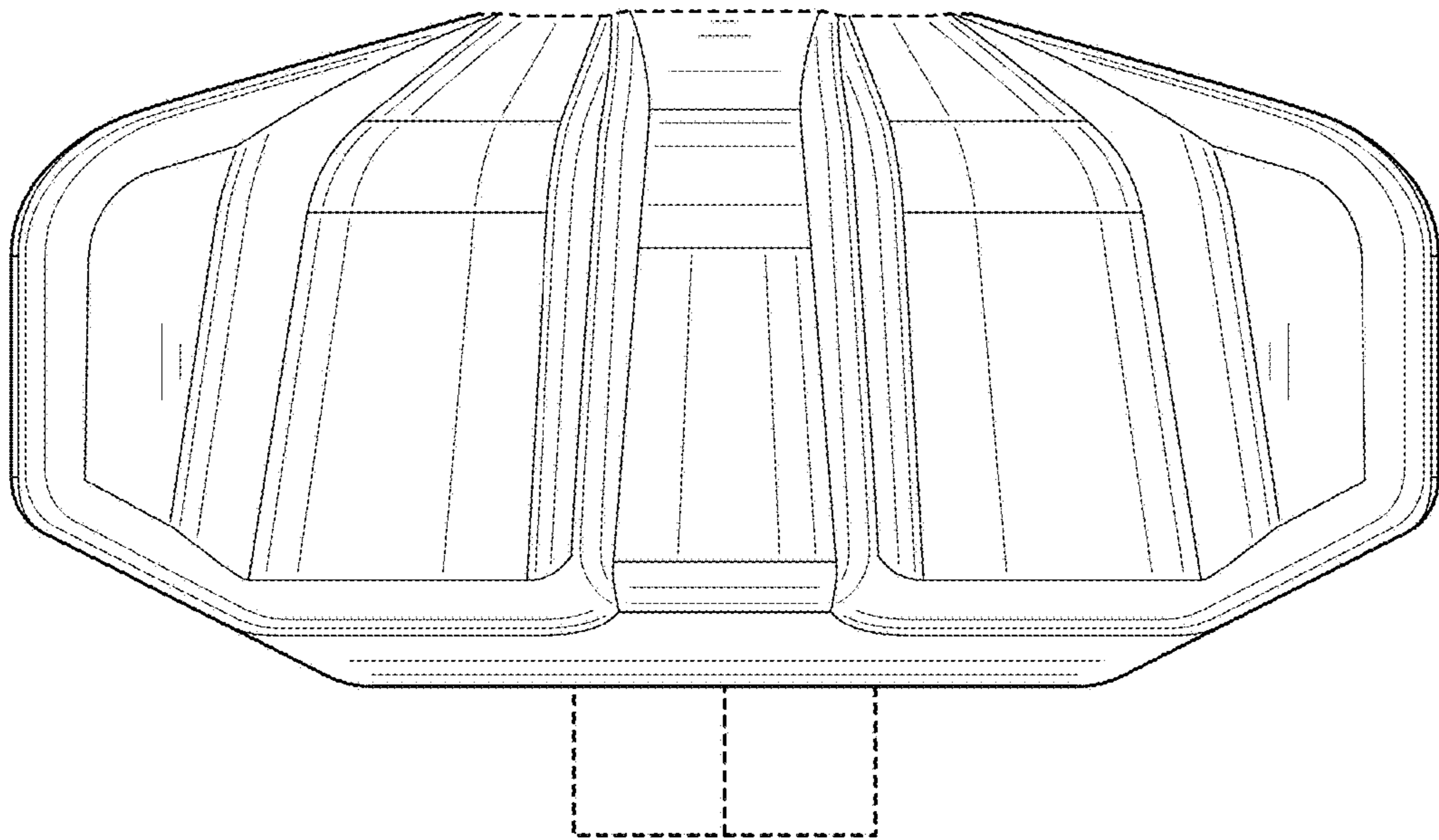

FIG. 4

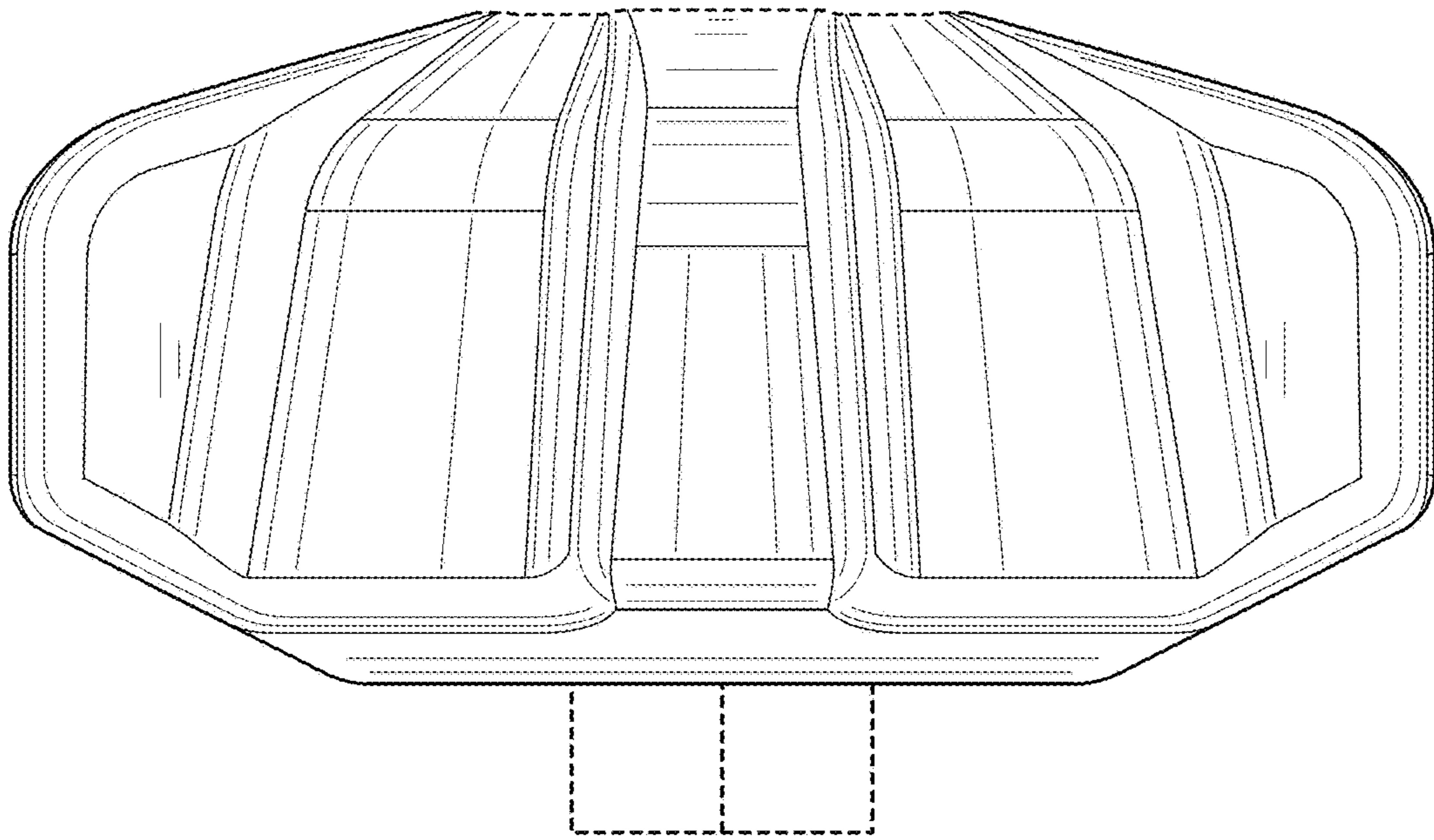

FIG. 5

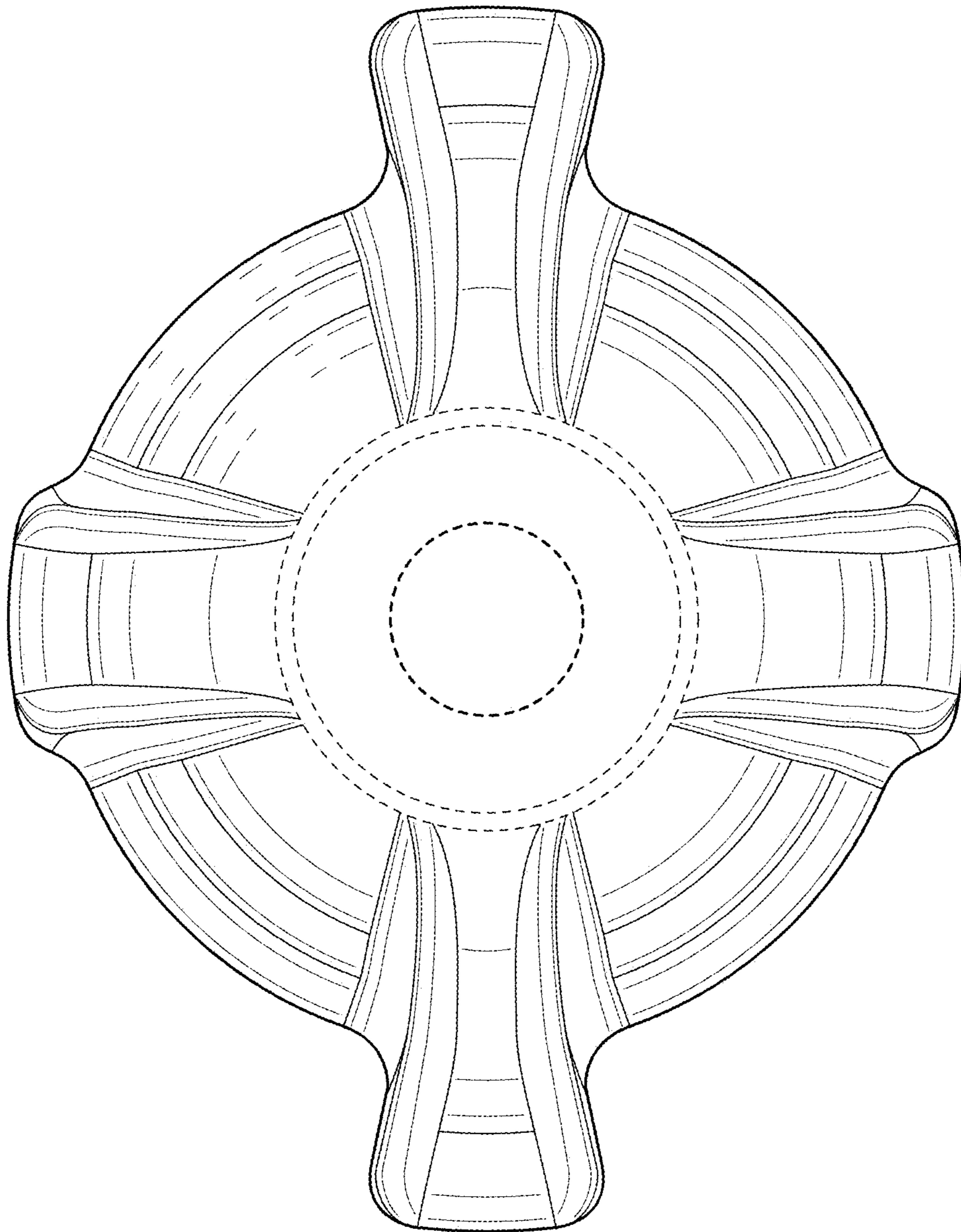

FIG. 6

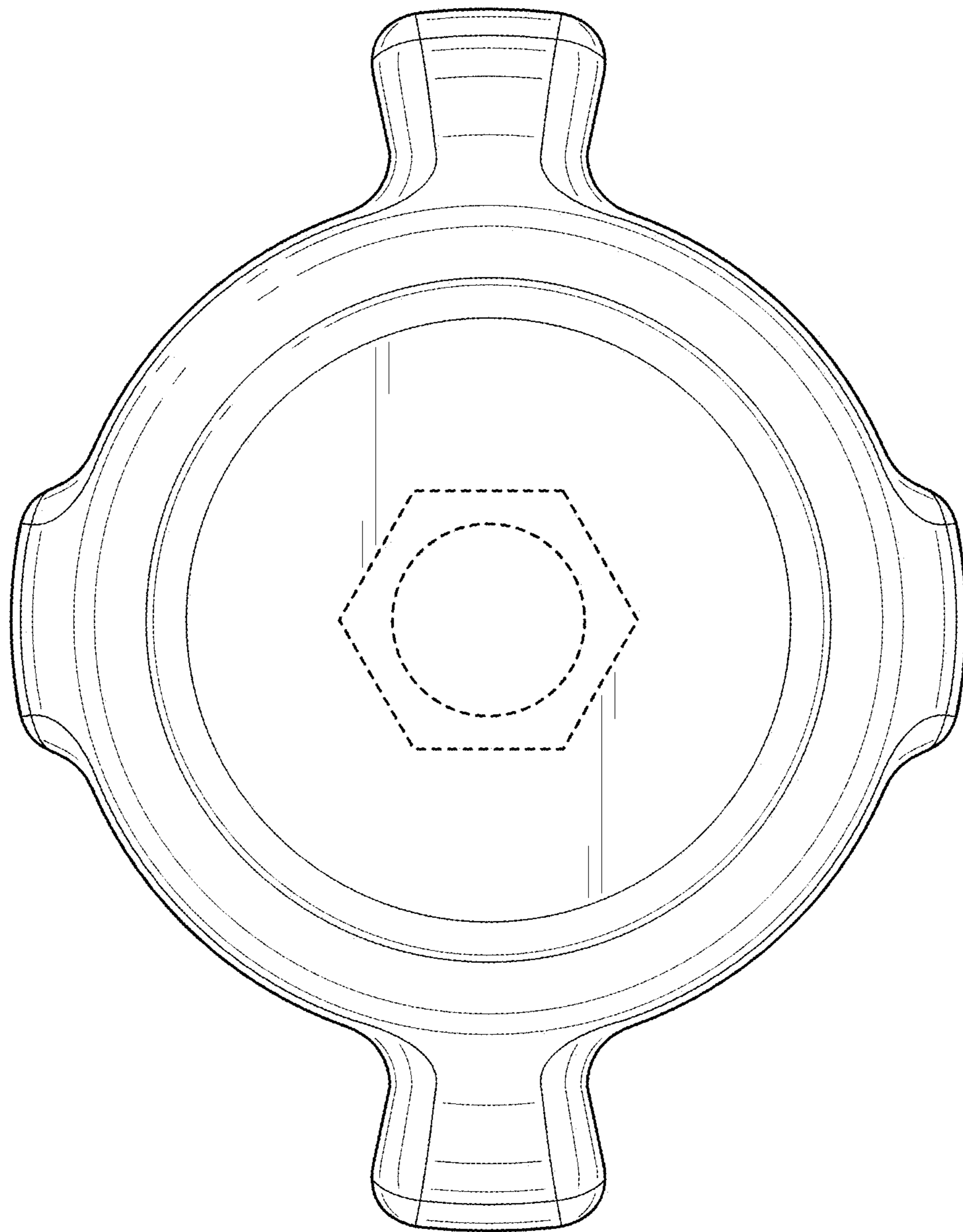

FIG. 7