



US00D859110S

(12) **United States Design Patent**
Miyazawa

(10) **Patent No.:** **US D859,110 S**

(45) **Date of Patent:** **** Sep. 10, 2019**

(54) **WIRE-TENSIONING DEVICE FOR
LIVE-WIRE SEPARATING TOOL**

(71) Applicant: **NAGAKI SEIKI CO., LTD.**, Osaka
(JP)

(72) Inventor: **Tomoharu Miyazawa**, Osaka (JP)

(73) Assignee: **NAGAKI SEIKI CO., LTD.**, Osaka
(JP)

(**) Term: **15 Years**

(21) Appl. No.: **29/616,631**

(22) Filed: **Sep. 7, 2017**

(30) **Foreign Application Priority Data**

Feb. 10, 2017 (ID) A00201700298

(51) **LOC (12) Cl.** **08-05**

(52) **U.S. Cl.**
USPC **D8/44**

(58) **Field of Classification Search**
USPC D8/14, 44, 51; D12/159; D15/28;
D34/31

(Continued)

(56) **References Cited**

U.S. PATENT DOCUMENTS

4,372,429 A * 2/1983 Marx F16F 9/38
188/322.12
6,439,552 B1 * 8/2002 Ageishi H02G 7/02
188/379

(Continued)

FOREIGN PATENT DOCUMENTS

JP H08-331723 A 12/1996
JP 2012-213314 11/2012

OTHER PUBLICATIONS

U.S. Appl. No. 29/616,634 to Tomoharu Miyazawa, filed Sep. 7, 2017.

Primary Examiner — Philip S Hyder

(74) *Attorney, Agent, or Firm* — Greenblum & Bernstein
P.L.C.

(57) **CLAIM**

I claim the ornamental design for a wire-tensioning device for live-wire separating tool, as shown and described.

DESCRIPTION

FIG. 1 is a front elevational view of a wire-tensioning device for live-wire separating tool, showing my new design;

FIG. 2 is a rear view thereof;

FIG. 3 is a top view thereof;

FIG. 4 is a bottom view thereof;

FIG. 5 is a left side elevational view thereof;

FIG. 6 is a right side elevational view thereof;

FIG. 7 is a perspective view thereof;

FIG. 8 is a reference perspective view showing a usage state;

FIG. 9 is an enlarged partial view of the portion designated 9-9' in FIG. 3;

FIG. 10 is an enlarged partial view of the portion designated 10-10' in FIG. 1; and,

FIG. 11 is a cross-sectional view taken along line 11-11 in FIG. 1, without showing the internal mechanism.

The broken line showings of the ends in the cross section views form no part of the claimed design. The broken line showings of the power lines, ropes, supports, etc. in FIG. 8 are provided for purposes of environment and form no part of the claimed design.

The present article, a wire-tensioning device for a live-wire separating tool, constitutes a part of the live-wire separating tool for separating cut wires from each other in overhead wiring work by non-power outage method.

In the present article, a rod can be telescopically extended/retracted from/into a cylinder by applying rotational force with a rotating tool through a rotating tool insertion hole shown in "REFERENCE PERSPECTIVE VIEW INDICATING A NAME OF EACH PART."

In the non-power outage method, as illustrated in "REFERENCE PERSPECTIVE VIEW SHOWING A USAGE STATE," the live-wire separating tool comprises the present article, and wire grippers respectively connected with locking tools provided on both ends of the present article through

(Continued)

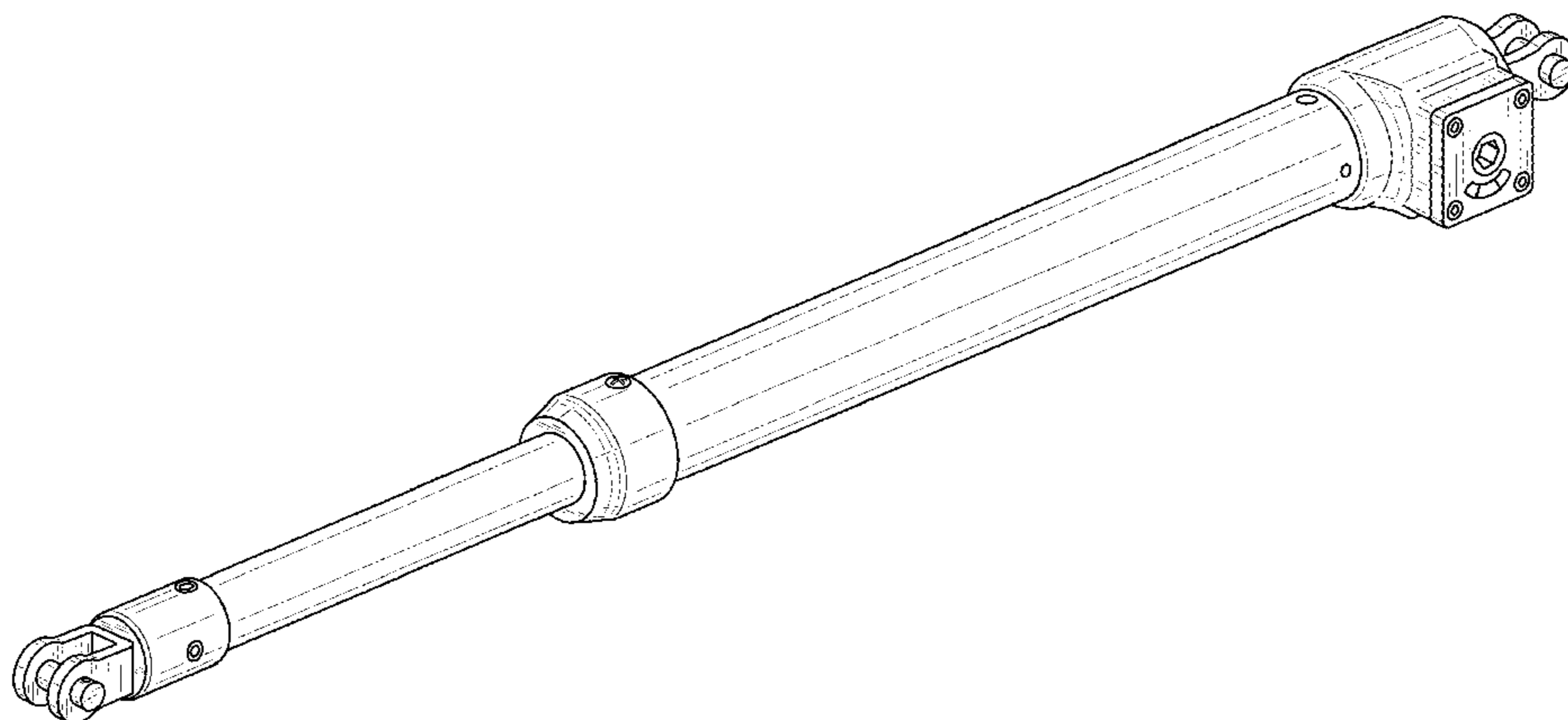

ropes. A wire of a power line is gripped by the two wire grippers, and the present article is telescopically shortened (i.e. the rod is telescopically retracted into the cylinder) with the rotating tool to loosen the wire between the two wire grippers. The loosened wire is cut into two and the cut wires are separated from each other with two respective wire supporters disposed on the cylinder in the opposite directions.

1 Claim, 7 Drawing Sheets

(58) **Field of Classification Search**

CPC B60M 1/00; B60M 1/26; H02G 7/02
See application file for complete search history.

(56) **References Cited**

U.S. PATENT DOCUMENTS

7,191,877	B2 *	3/2007	Norgaard	F16F 9/3235 188/274
D553,545	S *	10/2007	Nygren	D12/159
8,672,301	B2 *	3/2014	Kimura	B60M 1/26 174/40 TD
8,702,072	B2 *	4/2014	Kimura	B60M 1/26 174/40 TD
9,531,178	B2 *	12/2016	Kimura	H02G 7/02
2010/0289196	A1 *	11/2010	Kimura	B60M 1/26 267/73
2011/0253443	A1 *	10/2011	Sasa	B60M 1/26 174/40 TD

* cited by examiner

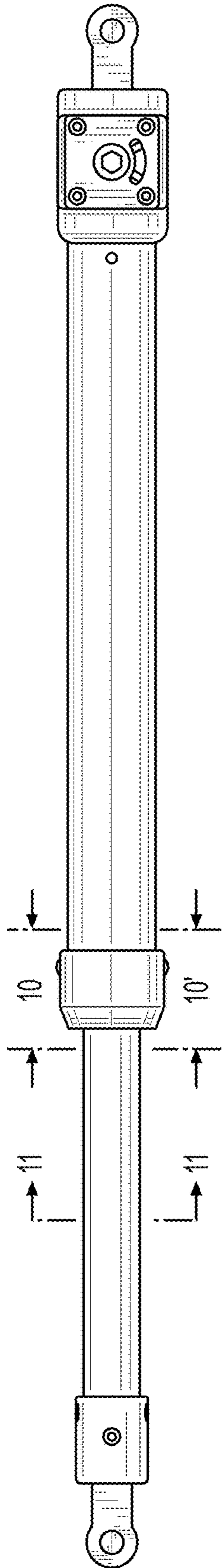

FIG. 1

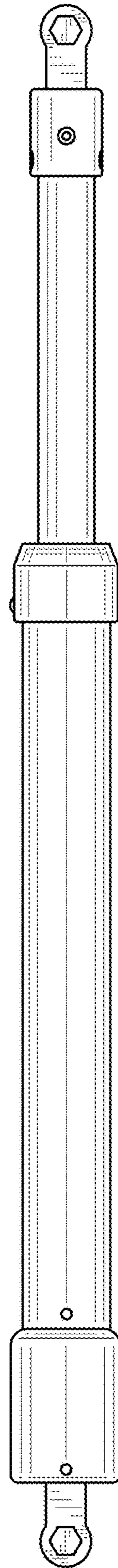

FIG. 2

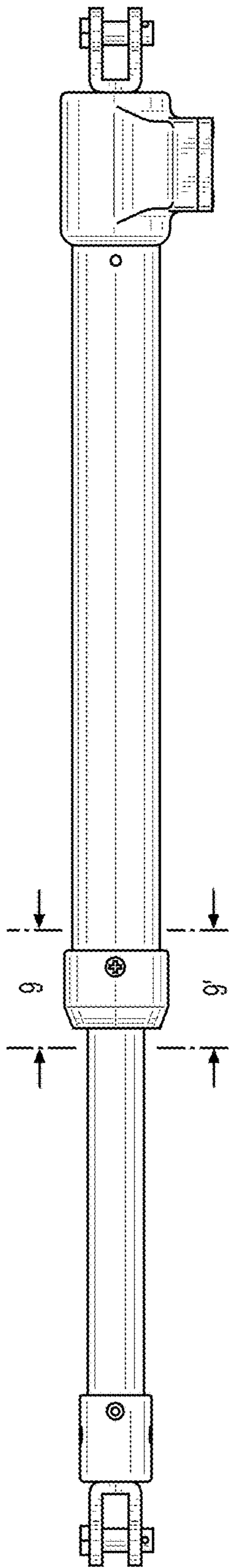

FIG. 3

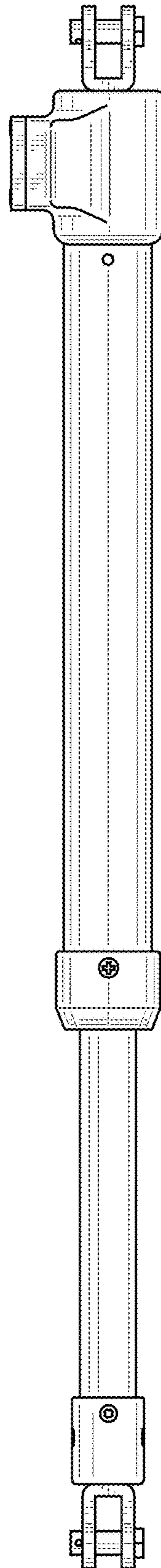

FIG. 4

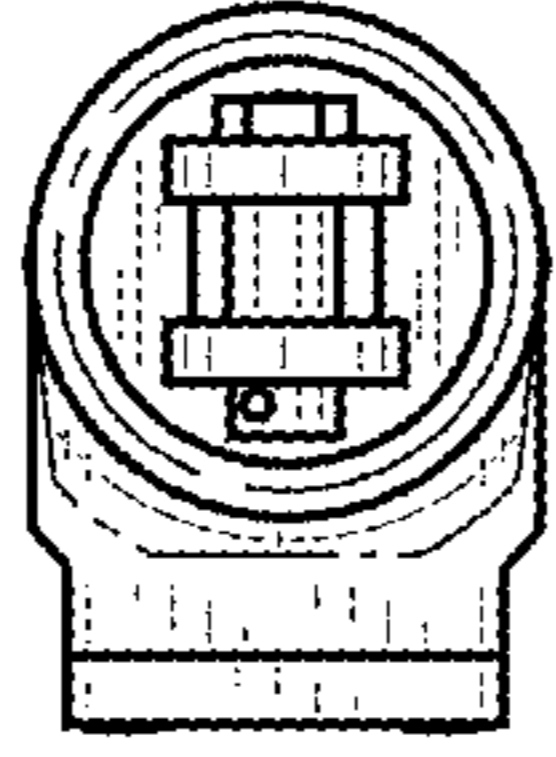

FIG. 6

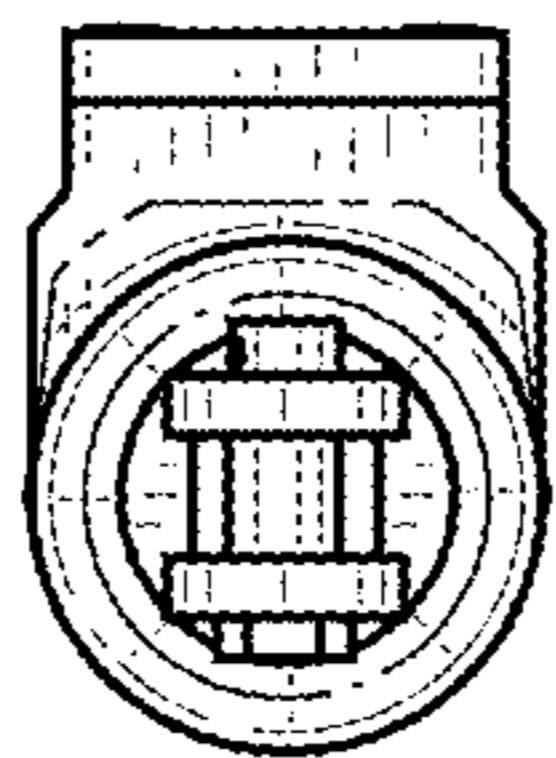

FIG. 5

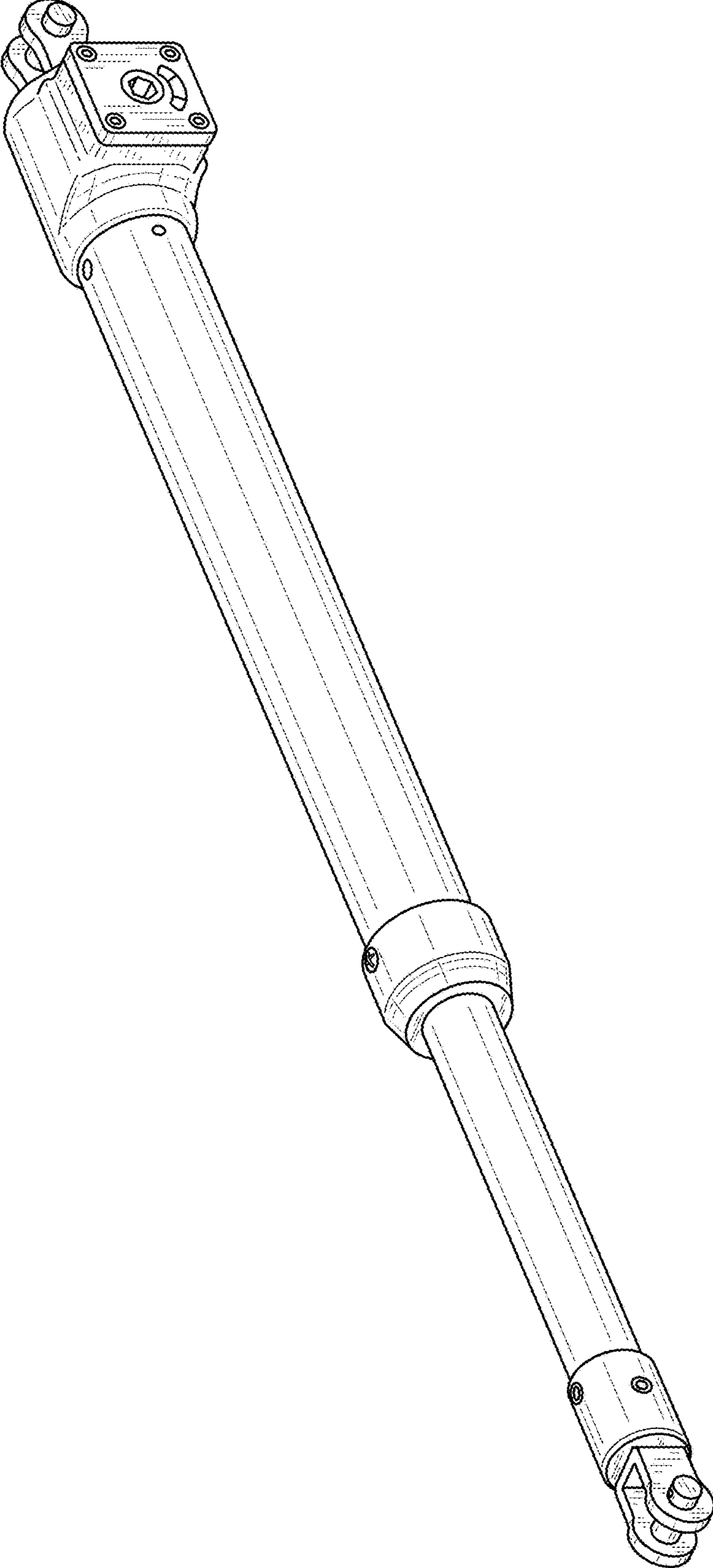

FIG. 7

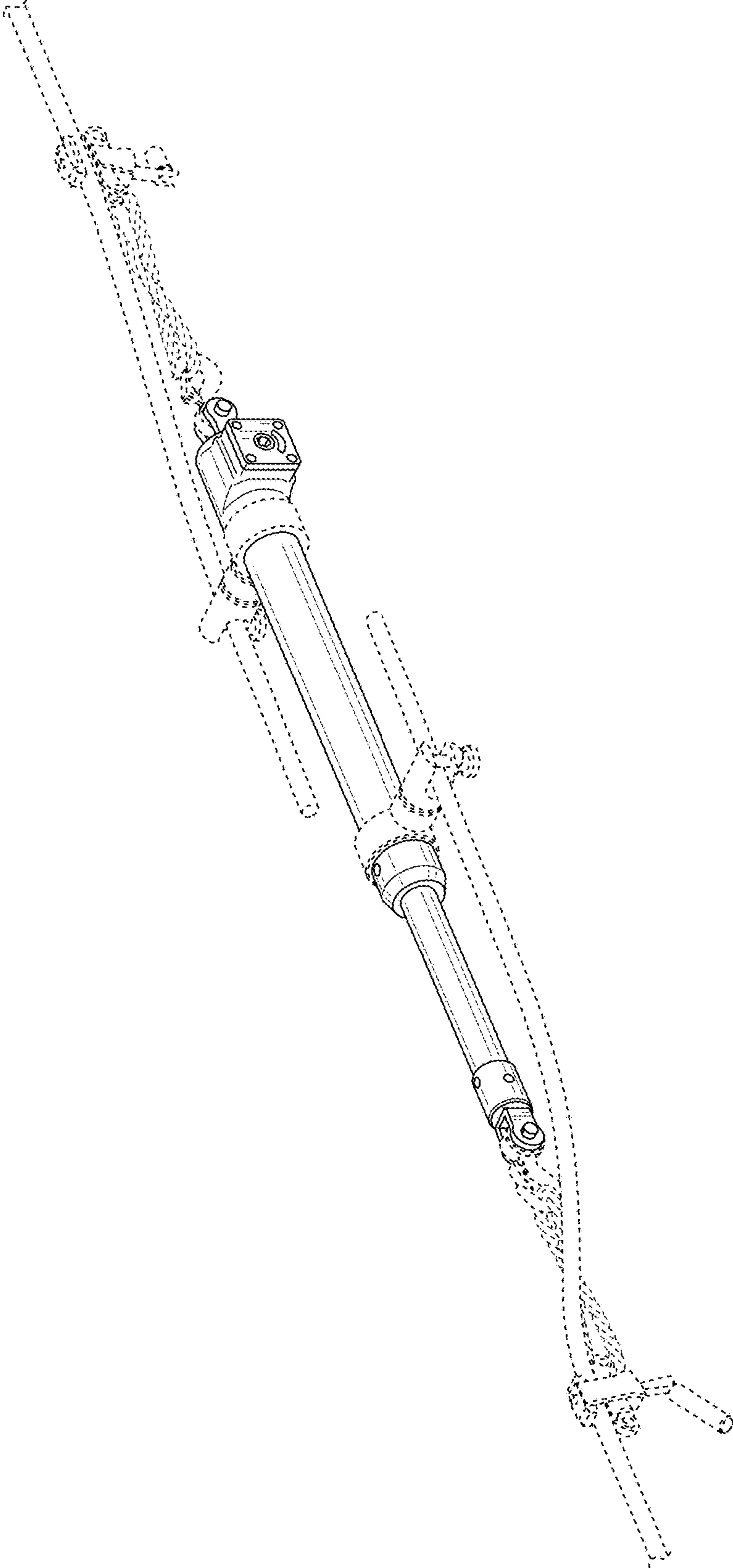

FIG. 8

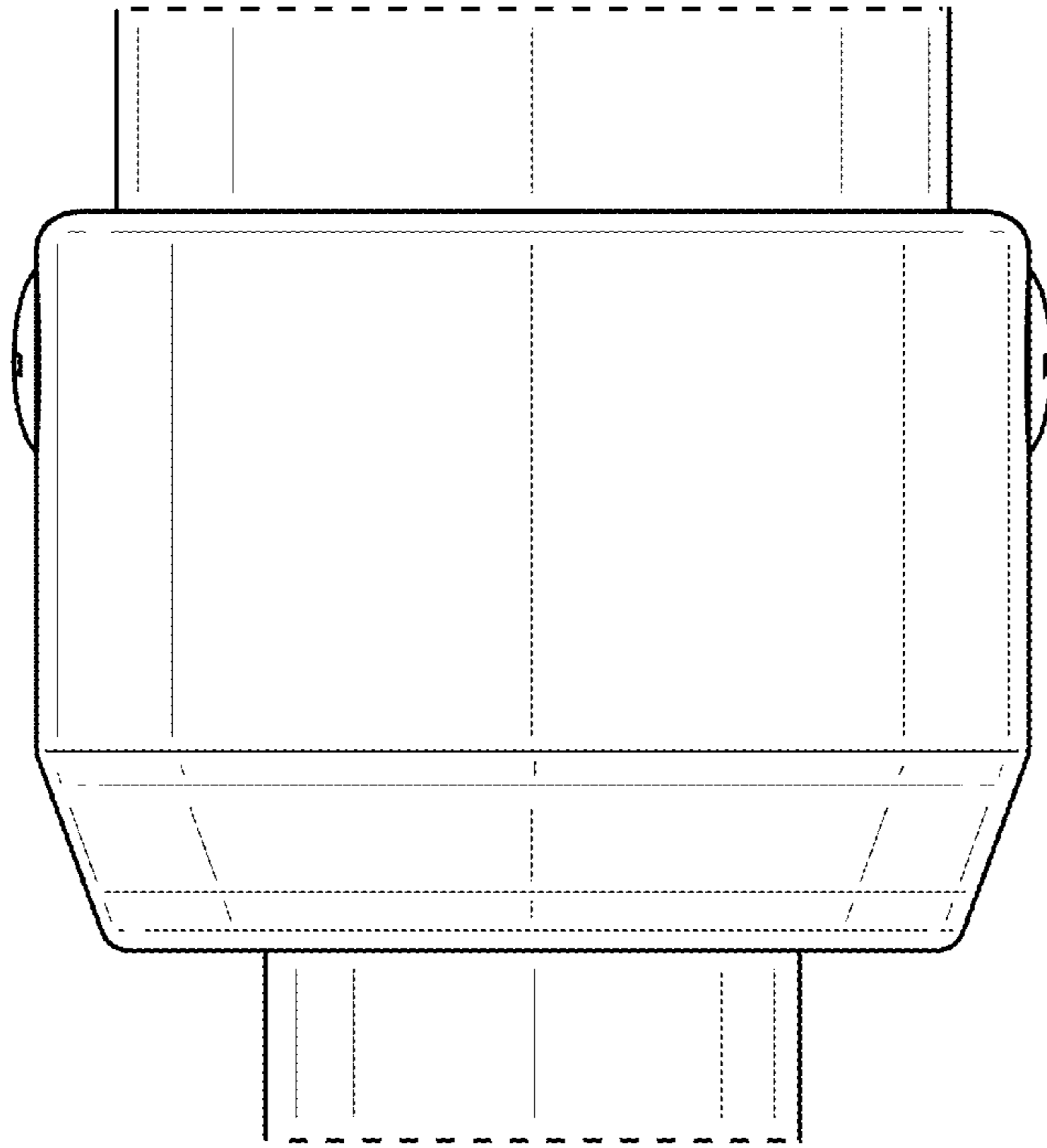

FIG. 9

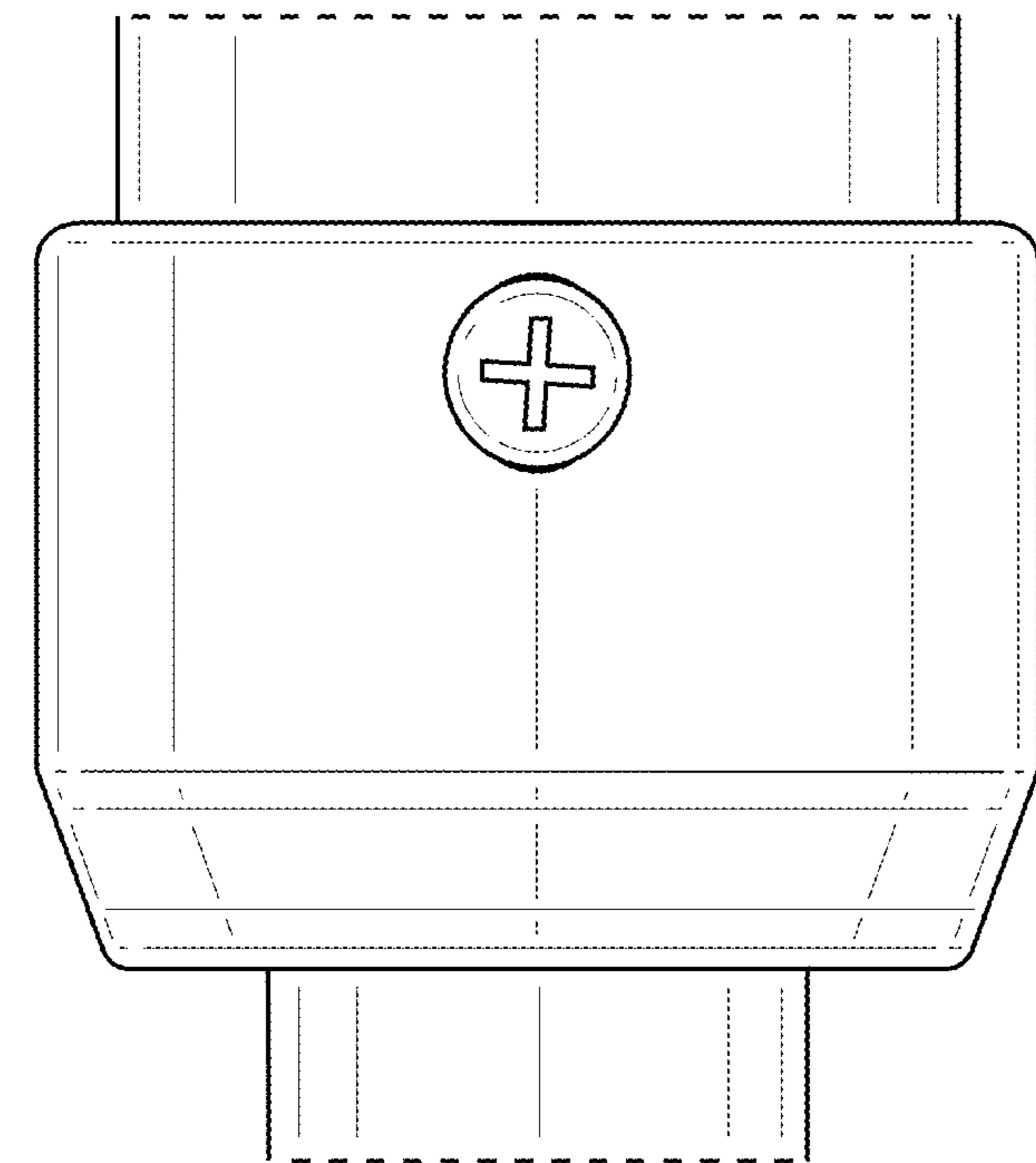

FIG. 10

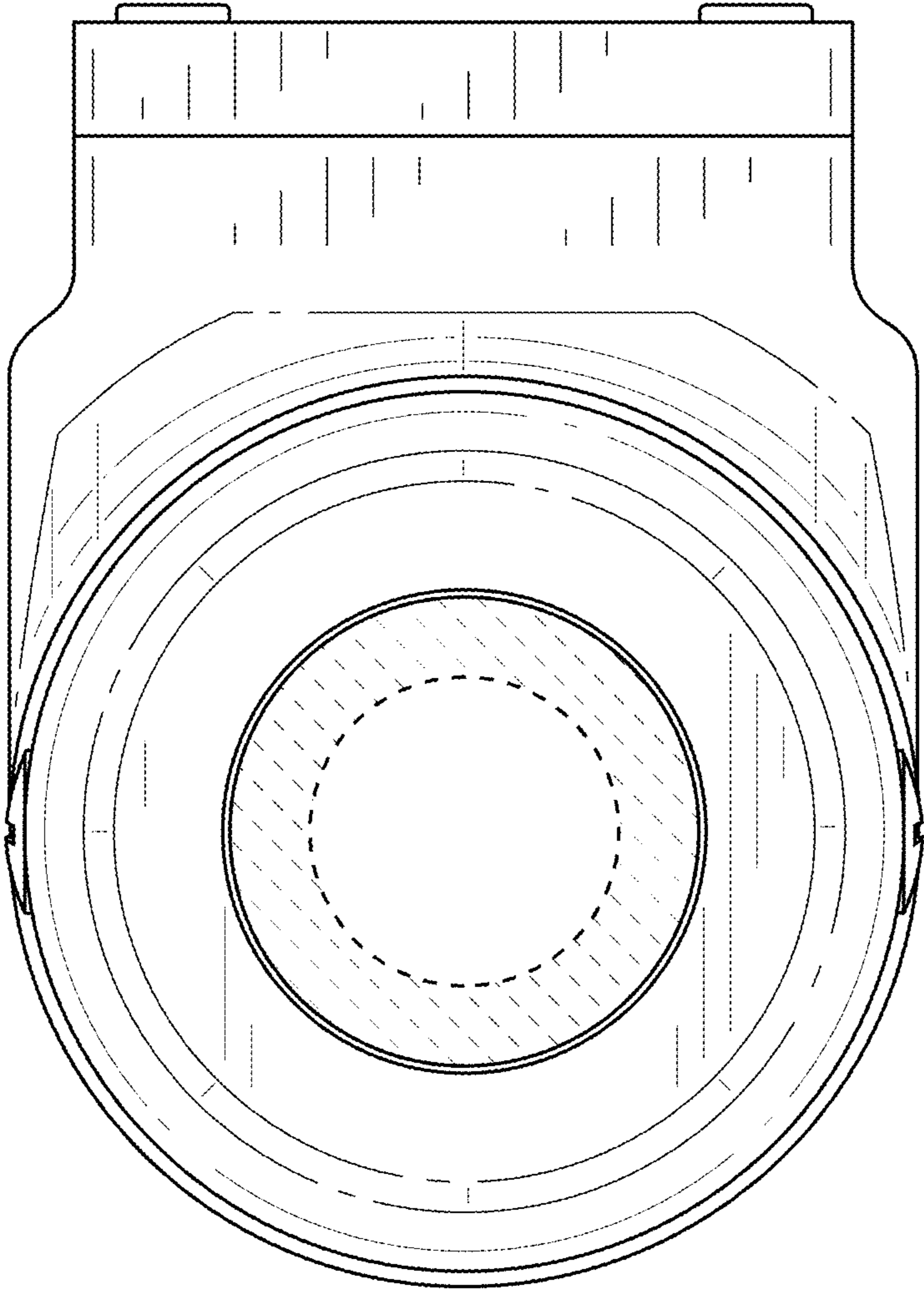

FIG. 11