



US00D857605S

(12) **United States Design Patent**  
**Mosingo et al.**

(10) **Patent No.:** **US D857,605 S**  
(45) **Date of Patent:** **\*\* Aug. 27, 2019**

- (54) **OPEN HEADACHE RACK**
- (71) Applicant: **Tectum Holdings Inc.**, Ann Arbor, MI (US)
- (72) Inventors: **Robert L. Mosingo**, Saline, MI (US);  
**Chad A. Carter**, Manchester, MI (US)
- (73) Assignee: **TECTUM HOLDINGS, INC.**, Ann Arbor, MI (US)
- (\*\*) Term: **15 Years**
- (21) Appl. No.: **29/653,514**
- (22) Filed: **Jun. 15, 2018**
- (51) **LOC (12) Cl.** ..... **12-06**
- (52) **U.S. Cl.**  
USPC ..... **D12/222**
- (58) **Field of Classification Search**  
USPC ..... D12/167, 183, 222, 223, 181, 190, 191,  
D12/401, 406, 412, 414, 414.1  
CPC ..... B60R 9/06; B60R 9/045; B60R 11/00;  
B60R 21/00; B60R 21/02; B60R 21/026;  
B60R 2021/0083; B60R 2021/0074;  
B60R 3/002; B60J 1/2008; B60J 1/2088;  
B62D 33/0207; B60Q 1/2661  
See application file for complete search history.

D672,705 S \* 12/2012 Kennedy ..... D12/412  
 8,668,124 B2 3/2014 Kennedy et al.  
 D731,399 S 6/2015 Bluhm  
 9,132,784 B2 9/2015 Harrison  
 9,637,178 B1 \* 5/2017 Diller ..... B60R 3/002  
 (Continued)

**OTHER PUBLICATIONS**

Safety Rack from Backrack, Inc. (<http://backrack.ca/truck-racks/safety-rack.html>) (Last accessed Jun. 25, 2018).  
 (Continued)

*Primary Examiner* — Sandra S Snapp  
*Assistant Examiner* — Ieisha N Price  
 (74) *Attorney, Agent, or Firm* — The Dobrusin Law Firm, P.C.; Daniel P. Aleksynas

(57) **CLAIM**

The ornamental design for an open headache rack, as shown and described.

**DESCRIPTION**

FIG. 1 is a perspective view of the present design connected to a vehicle.  
 FIG. 2 is a perspective view of the present design;  
 FIG. 3 is a front elevational view of FIG. 2.  
 FIG. 4 is a rear elevational view of FIG. 2.  
 FIG. 5 is a top plan view of FIG. 2.  
 FIG. 6 is a bottom plan view of FIG. 2.  
 FIG. 7 is a right side elevational view of FIG. 2, with the left side view being a mirror image thereof; and,  
 FIG. 8 is a perspective view of the present design connected to a vehicle with vehicle components.  
 The broken lines showing of the truck, light bar and cargo box in FIGS. 1 and 8 illustrates the environment of the claimed design and forms no part thereof. The remaining broken lines in the drawings illustrate portions of the open headache rack and form no part of the claimed design.

(56) **References Cited**

**U.S. PATENT DOCUMENTS**

- D206,654 S \* 1/1967 Smith ..... D12/183
- 4,611,824 A 9/1986 McIntosh
- 4,715,643 A \* 12/1987 Butler L ..... B60J 1/2088  
264/138
- 4,953,908 A 9/1990 Dondlinger
- D388,385 S \* 12/1997 Protz, Sr. .... D12/167
- 6,983,968 B2 1/2006 Brauer et al.
- 7,121,585 B2 10/2006 Cole
- D644,591 S 9/2011 Andonian
- D647,025 S \* 10/2011 Kennedy ..... D12/406

**1 Claim, 6 Drawing Sheets**

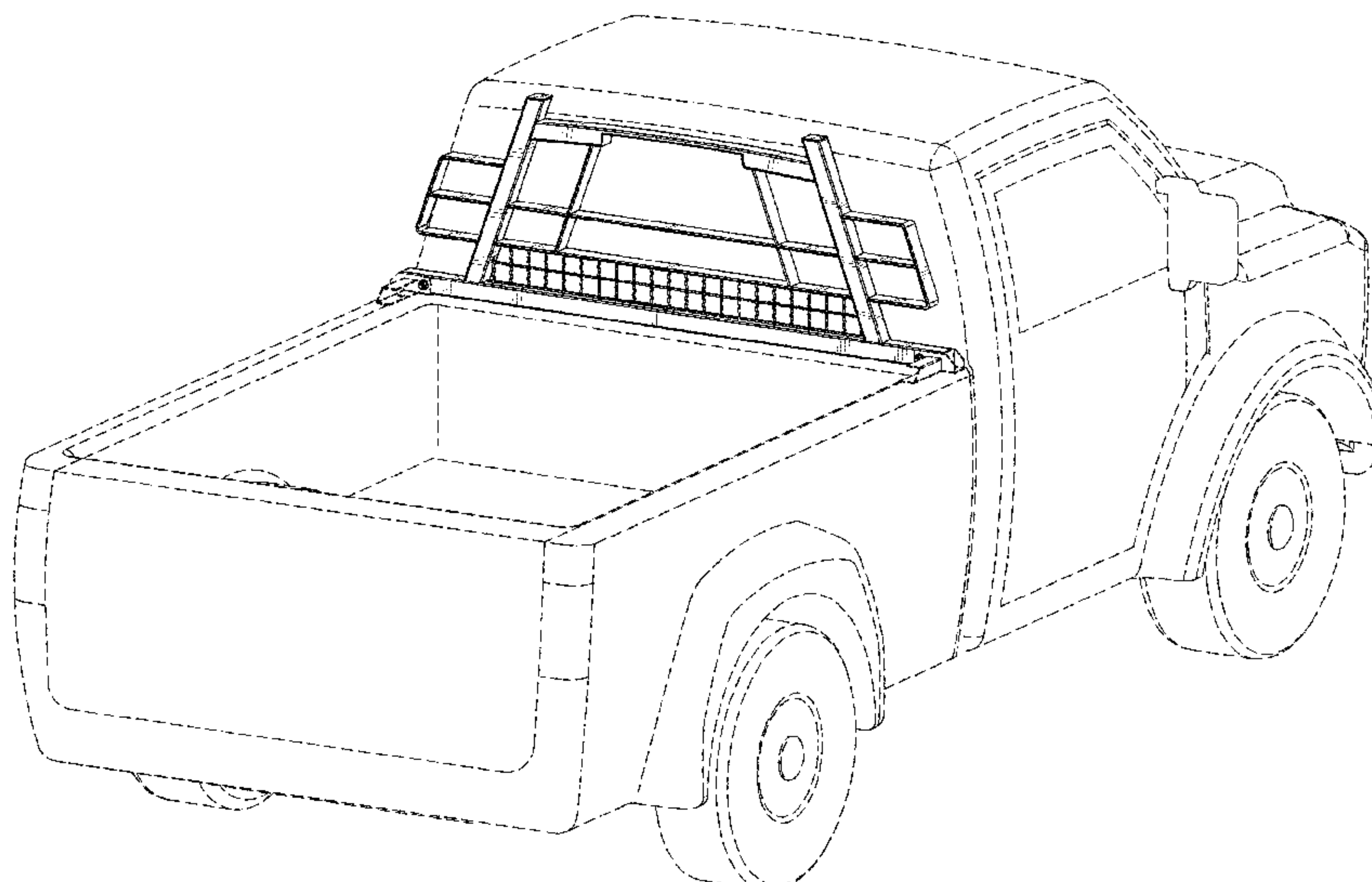

(56)

**References Cited**

U.S. PATENT DOCUMENTS

D840,905 S \* 2/2019 Parzyck ..... D12/222  
2003/0011180 A1 1/2003 Coffman et al.  
2005/0052055 A1\* 3/2005 Cole ..... B60Q 1/2661  
296/190.03  
2005/0093320 A1\* 5/2005 Brauer ..... B62D 33/0207  
296/3  
2011/0108590 A1\* 5/2011 Kennedy ..... B60R 9/045  
224/402  
2015/0197202 A1\* 7/2015 Harrison ..... B60R 9/045  
296/3  
2018/0118148 A1\* 5/2018 Parzyck ..... B60R 21/02

OTHER PUBLICATIONS

Louvered Rack from Backrack, Inc. (<http://backrack.ca/truck~racks/louvered~rack.html>) (Last accessed Jun. 25, 2018).  
Half Safety Rack from Backrack, Inc. (<http://backrack.ca/truck~racks/half~safety~rack.html>) (Last accessed Jun. 25, 2018).  
Original Backrack from Backrack, Inc. (<http://backrack.ca/truck~racks/backrack.html>) (Last accessed Jun. 25, 2018).  
Potentially Related U.S. Appl. No. 29/653,486, filed Jun. 15, 2018.  
Potentially Related U.S. Appl. No. 29/653,511, filed Jun. 15, 2018.

\* cited by examiner

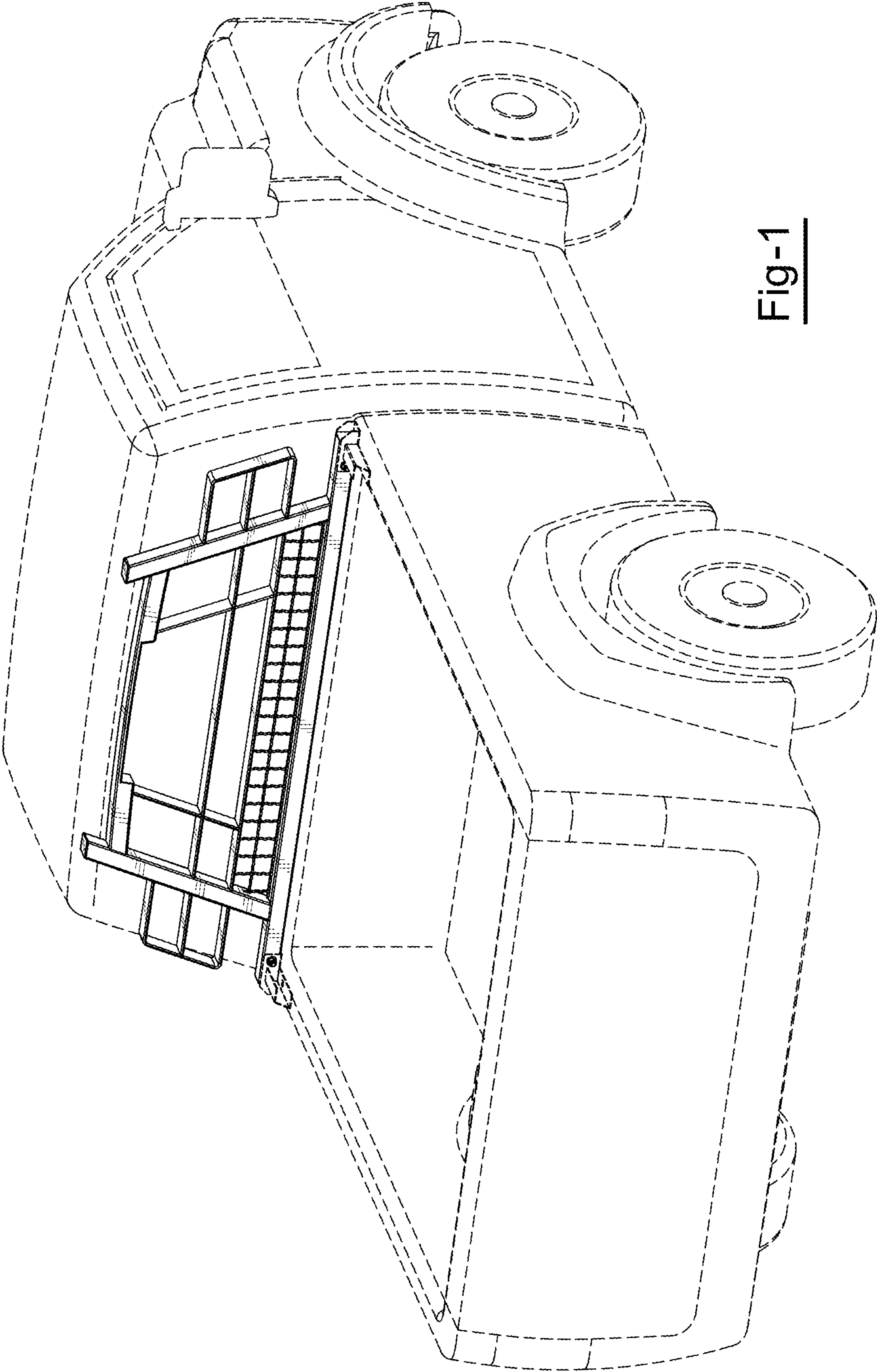

Fig-1



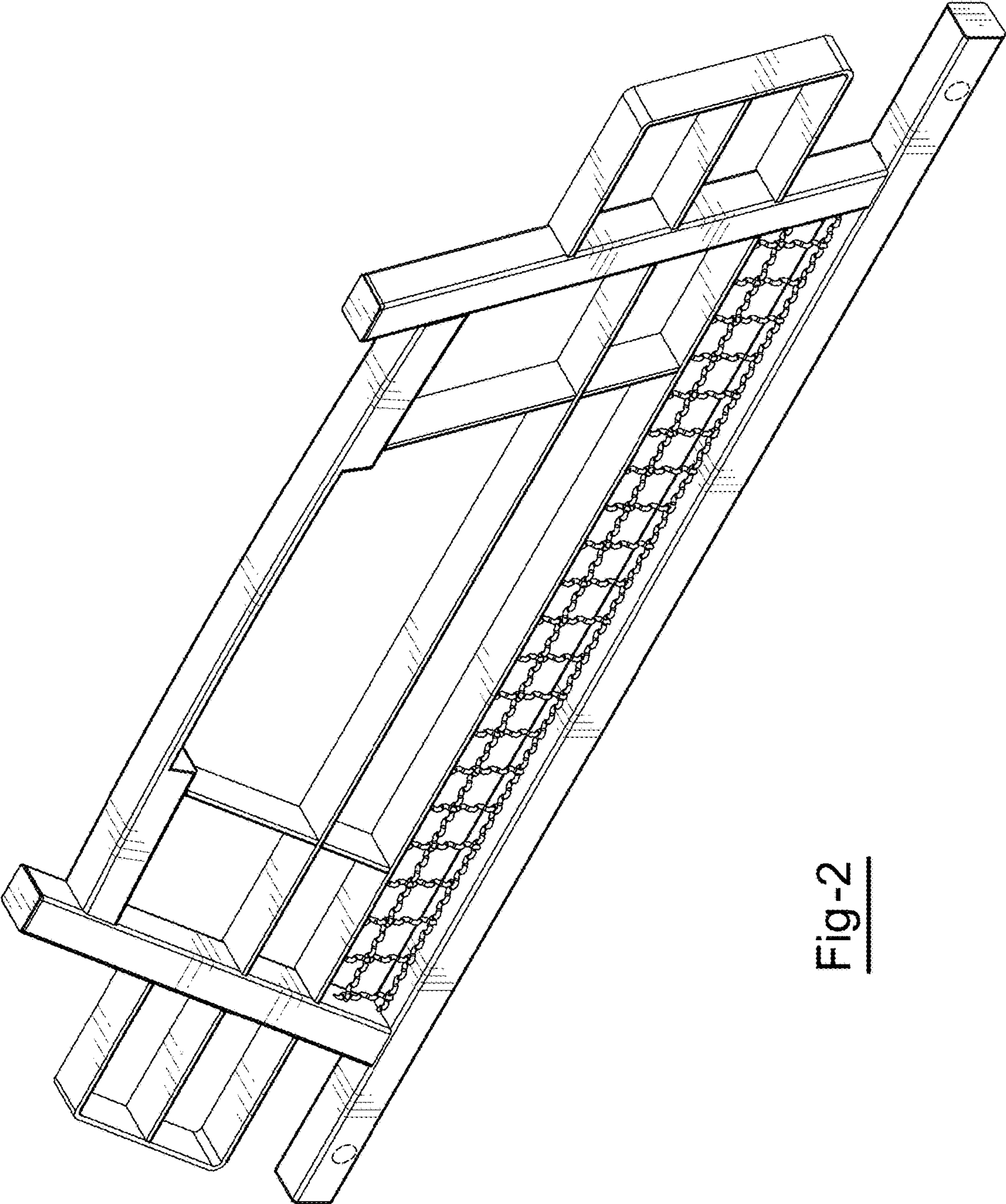

Fig-2

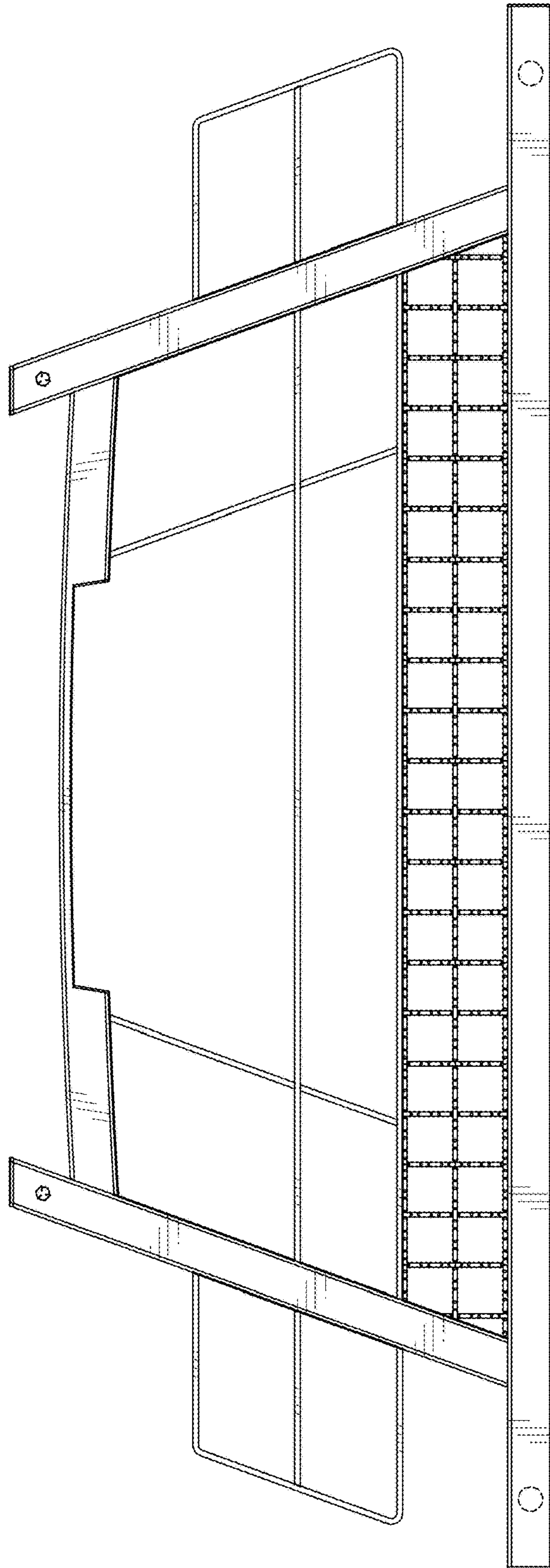

Fig-3

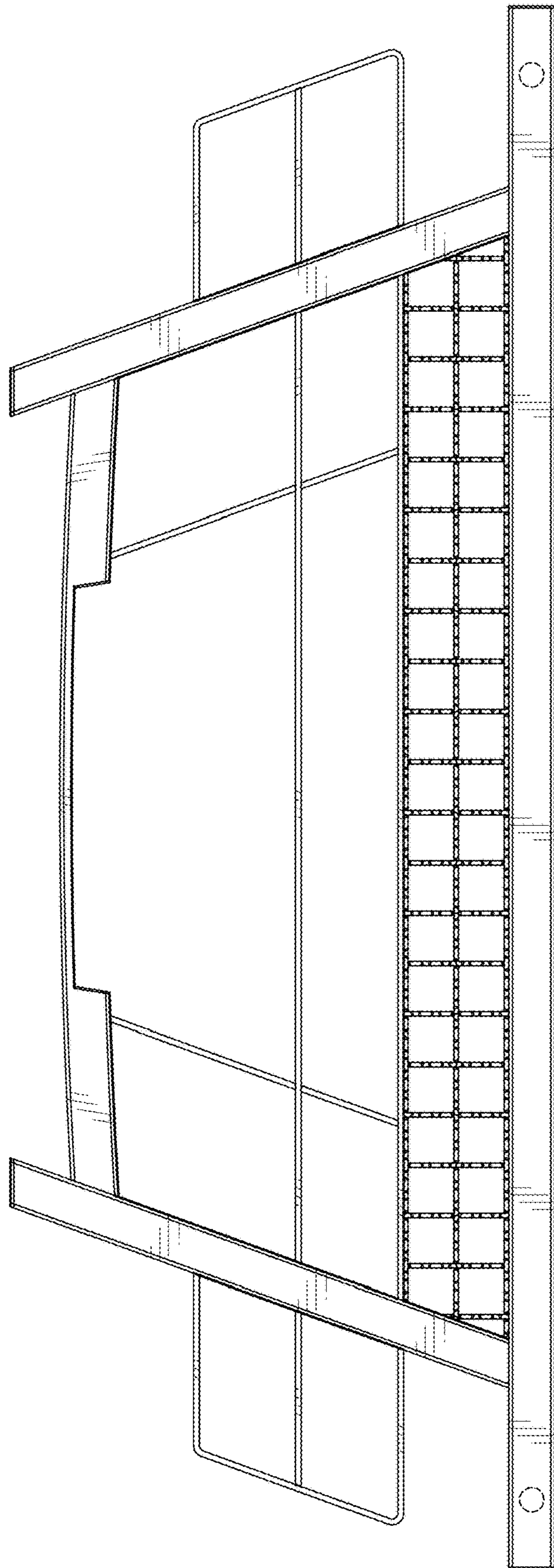

Fig-4

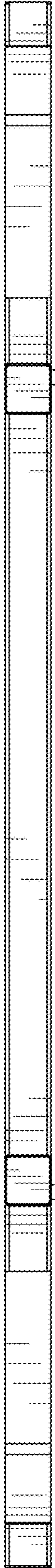

Fig-5



Fig-6



Fig-7



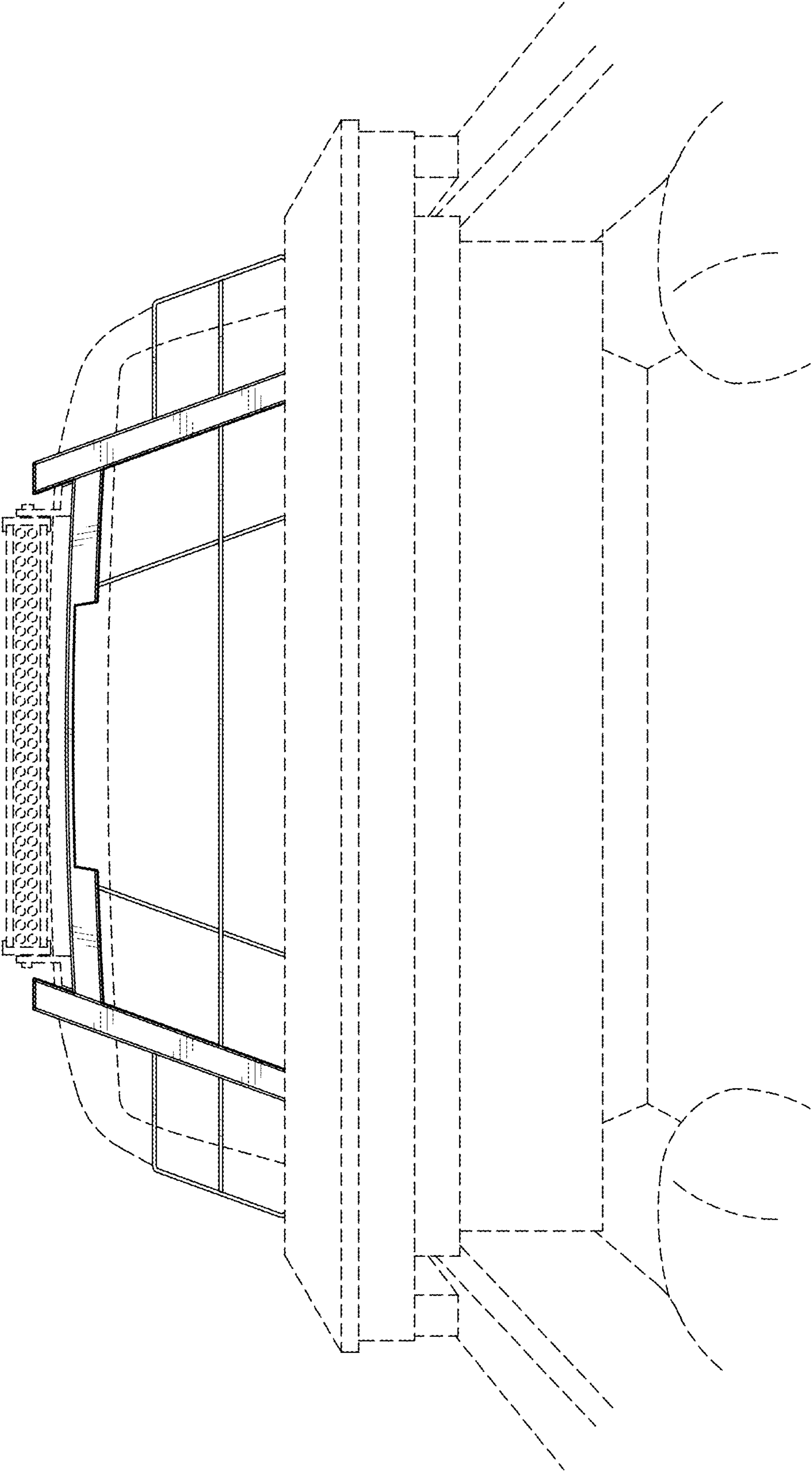

Fig-8