



US00D857066S

(12) **United States Design Patent** (10) **Patent No.:** **US D857,066 S**
Young (45) **Date of Patent:** **** Aug. 20, 2019**

(54) **SWING HAMMER**

FOREIGN PATENT DOCUMENTS

(71) Applicant: **Roger Young**, Rock Falls, IL (US)

CA 2613956 A1 2/2009

(72) Inventor: **Roger Young**, Rock Falls, IL (US)

CA 2720159 A1 5/2011

DE 10215833 A1 11/2003

EP 1444990 A1 8/2004

(**) Term: **15 Years**

OTHER PUBLICATIONS

(21) Appl. No.: **29/672,702**

Genesis III, Inc., "Hammer Mill Hammers", <http://h3hammers.com/hammer-mill-parts/hammer-mill-hammers/#forged>, pp. 1-14, accessed on Dec. 7, 2017.

(22) Filed: **Dec. 7, 2018**

(Continued)

Related U.S. Application Data

(62) Division of application No. 29/628,676, filed on Dec. 6, 2017, now Pat. No. Des. 839,934.

Primary Examiner — Patricia A Palasik

(51) **LOC (12) Cl.** **15-09**

(74) *Attorney, Agent, or Firm* — McKee, Voorhees & Sease, PLC

(52) **U.S. Cl.**

USPC **D15/123**

(58) **Field of Classification Search**

USPC D15/123, 124, 125, 126, 131

CPC B02C 13/00; B02C 13/04; B02C 13/28

See application file for complete search history.

(57) **CLAIM**

The ornamental design for a swing hammer, as shown and described.

(56) **References Cited**

DESCRIPTION

U.S. PATENT DOCUMENTS

758,288	A	4/1904	Williams
858,772	A	7/1907	Williams
906,364	A	12/1908	Backus
1,016,979	A	2/1912	Williams
1,041,495	A	10/1912	Liggett et al.
1,085,692	A	2/1914	Liggett
1,266,894	A	5/1918	Williams
RE14,865	E	5/1920	Plaisted
RE14,920	E	7/1920	Morse et al.
1,433,042	A	10/1922	Sedberry
1,444,990	A	2/1923	Wauthier
1,630,021	A	5/1927	Lucas
1,678,723	A	7/1928	Clement
1,693,058	A	11/1928	Shelton
1,759,905	A	5/1930	Keith
1,760,097	A	5/1930	Williams
1,761,038	A	6/1930	Harley

FIG. 1 is a front perspective view of a swing hammer; FIG. 2 is a rear perspective view thereof; FIG. 3 is a front elevation view thereof, the rear elevation view being a mirror image thereof; FIG. 4 is a left side elevation view thereof, the right side elevation view being a mirror image thereof; FIG. 5 is a top elevation view thereof; FIG. 6 is a bottom elevation view thereof; FIG. 7 is another front perspective view thereof; FIG. 8 is another left side elevation view thereof, the right side elevation view being a mirror image thereof; FIG. 9 is another top elevation view thereof; and, FIG. 10 is another bottom elevation view thereof. Environmental structures shown in broken lines in FIGS. 1-10 form no part of the claimed design.

(Continued)

1 Claim, 6 Drawing Sheets

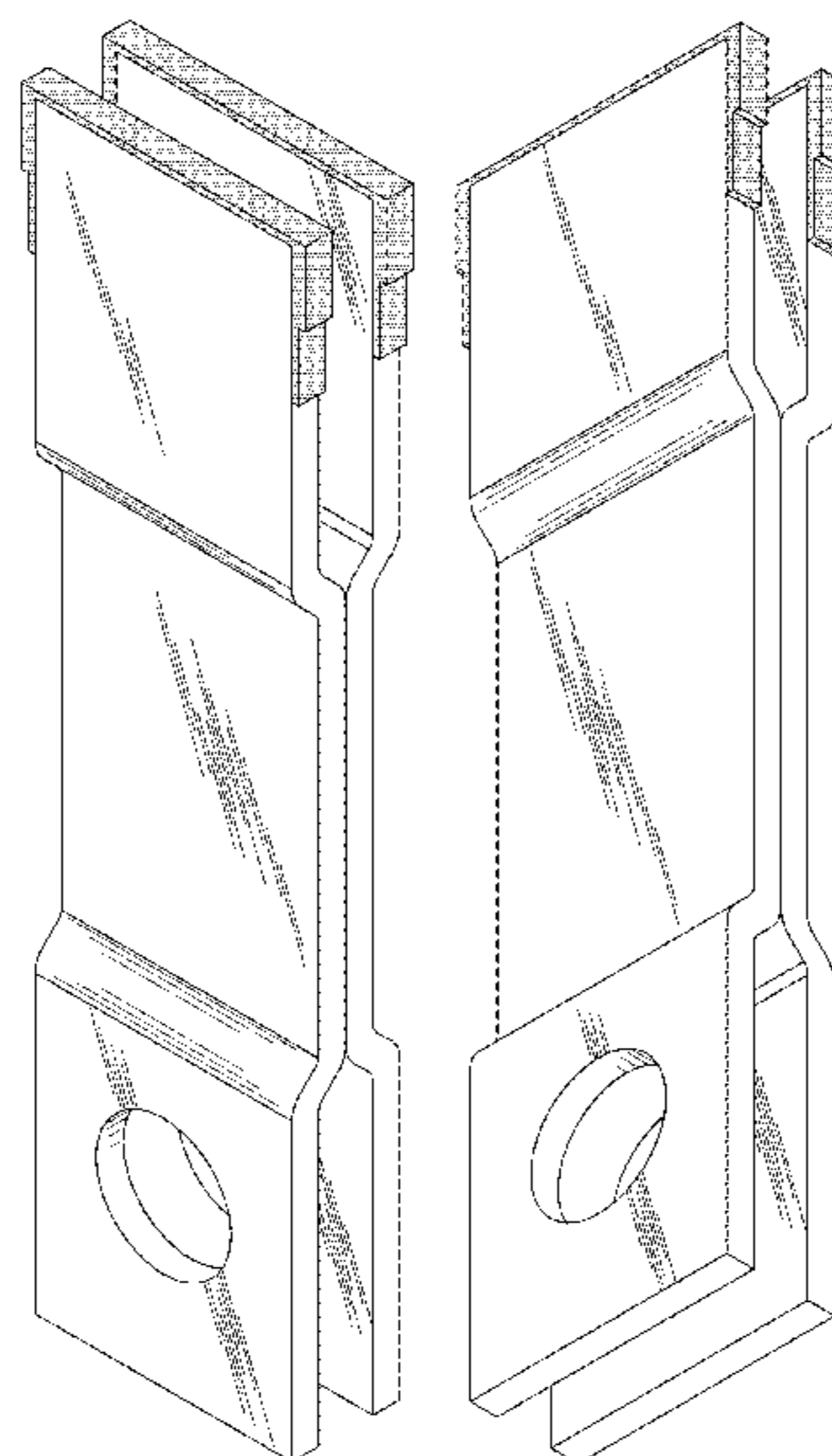

(56)

References Cited

U.S. PATENT DOCUMENTS

- | | | | | | |
|-------------|---------|--------------------|-----------------|---------|---------------------|
| 1,787,526 A | 1/1931 | Honstain | 5,465,912 A | 11/1995 | Graybill et al. |
| 1,821,912 A | 9/1931 | Pfeiffer | 5,570,849 A | 11/1996 | Anderson |
| 1,827,986 A | 10/1931 | Iglehart | 5,605,291 A | 2/1997 | Doskocil |
| 1,829,325 A | 10/1931 | Alfred | 5,611,496 A | 3/1997 | Fleenor |
| 1,854,844 A | 4/1932 | Kaemmerling | 5,628,467 A | 5/1997 | Graveman |
| 1,889,129 A | 11/1932 | Nielsen | 5,692,688 A | 12/1997 | Waitman et al. |
| 1,911,718 A | 5/1933 | Saunders | 5,722,607 A | 3/1998 | Hellmich |
| 1,927,986 A | 9/1933 | Levy | 5,842,653 A | 12/1998 | Elliott et al. |
| 1,947,784 A | 2/1934 | Armstrong | 5,904,306 A | 5/1999 | Elliott et al. |
| 1,954,175 A | 4/1934 | Jensen | 5,984,216 A | 11/1999 | Andela et al. |
| 1,997,553 A | 4/1935 | Taylor, Jr. et al. | 6,045,072 A | 4/2000 | Zehr |
| 2,015,581 A | 9/1935 | Armour | 6,131,838 A | 10/2000 | Balvanz et al. |
| 2,207,455 A | 7/1940 | Clement | 6,142,400 A | 11/2000 | Balvanz et al. |
| 2,237,510 A | 4/1941 | Tankersley | 6,260,778 B1 | 7/2001 | Wenger |
| 2,244,577 A | 6/1941 | Schreiber | 6,299,082 B1 | 10/2001 | Smith |
| 2,404,775 A | 6/1946 | Ehmann | 6,364,227 B1 | 4/2002 | Dorscht |
| 2,404,778 A | 7/1946 | Allison | 6,394,375 B1 | 5/2002 | Balvanz et al. |
| 2,460,279 A | 2/1949 | Ehmann | 6,394,378 B1 | 5/2002 | Ragnarsson |
| 2,531,597 A | 11/1950 | Anderson | 6,419,173 B2 | 7/2002 | Balvanz et al. |
| 2,566,758 A | 9/1951 | Anderson | 6,464,157 B1 | 10/2002 | Balvanz et al. |
| 2,566,798 A | 9/1951 | Hiller | 6,481,654 B1 | 11/2002 | Balvanz et al. |
| 2,602,597 A | 7/1952 | Ball | 6,494,394 B1 | 12/2002 | Balvanz et al. |
| 2,607,538 A | 8/1952 | Larson | 6,517,020 B1 | 2/2003 | Smith |
| 2,763,439 A | 9/1956 | Mankoff | 6,520,440 B2 | 2/2003 | Ragnarsson |
| 3,022,018 A | 2/1962 | Knight | 6,622,951 B1 | 9/2003 | Recker et al. |
| 3,045,934 A | 7/1962 | Eilers | 6,622,951 B1 | 9/2003 | Recker et al. |
| 3,058,676 A | 10/1962 | Hermann | 6,971,598 B2 | 12/2005 | Schillinger et al. |
| 3,222,854 A | 12/1965 | Barth | 7,140,569 B2 | 11/2006 | Young |
| 3,278,126 A | 10/1966 | Ratkowski | D536,350 S | 2/2007 | Young |
| 3,322,356 A | 5/1967 | Toews | D536,351 S | 2/2007 | Young |
| 3,379,383 A | 4/1968 | Stepanek | D536,352 S | 2/2007 | Young |
| 3,471,093 A | 10/1969 | Wienert | D544,503 S | 6/2007 | Young |
| 3,482,789 A | 12/1969 | Newell | D544,504 S | 6/2007 | Young |
| 3,549,095 A | 12/1970 | Ratkowski | D545,327 S | 6/2007 | Young |
| 3,598,008 A | 8/1971 | Jacobson et al. | D545,328 S | 6/2007 | Young |
| 3,627,212 A | 12/1971 | Stanton | D545,846 S | 7/2007 | Young |
| 3,682,401 A | 8/1972 | Jacobson et al. | D545,847 S | 7/2007 | Young |
| 3,738,586 A | 6/1973 | Fabert, Jr. | D550,728 S | 9/2007 | Young |
| 3,966,126 A | 6/1976 | Werner | D551,266 S | 9/2007 | Young |
| 3,966,128 A | 6/1976 | Anderson et al. | D551,267 S | 9/2007 | Young |
| 3,979,078 A | 9/1976 | Boddeker et al. | D552,638 S | 10/2007 | Willibald |
| 3,995,816 A | 12/1976 | Motek | D552,639 S | 10/2007 | Young |
| 3,997,121 A | 12/1976 | Motek | D555,679 S | 11/2007 | Young |
| 4,000,859 A | 1/1977 | Whitney | 7,325,761 B2 | 2/2008 | Chen et al. |
| 4,106,706 A | 8/1978 | Burrows | D573,163 S | 7/2008 | Young |
| 4,129,262 A | 12/1978 | Lowry | 7,419,109 B1 | 9/2008 | Ronfeldt et al. |
| 4,134,554 A | 1/1979 | Morlock | D588,174 S | 3/2009 | Young |
| 4,141,512 A | 2/1979 | Francis | 7,559,497 B2 | 7/2009 | Young |
| 4,142,687 A | 3/1979 | Potwin | 7,621,477 B2 | 11/2009 | Young |
| 4,162,767 A | 7/1979 | Hahn | D616,002 S | 5/2010 | Willibald |
| 4,166,583 A | 9/1979 | Ruckstuhl | 7,819,352 B2 | 10/2010 | Young |
| 4,177,956 A | 12/1979 | Fawcett | D637,633 S | 5/2011 | Young et al. |
| 4,202,504 A | 5/1980 | Cameron | 8,033,490 B1 | 10/2011 | Young et al. |
| 4,310,125 A | 1/1982 | Novotny | 8,613,403 B1 | 12/2013 | Young |
| 4,313,575 A | 2/1982 | Stepanek | 8,708,263 B2 | 4/2014 | Young et al. |
| 4,341,353 A | 7/1982 | Hamilton et al. | 8,800,903 B1 | 8/2014 | Young |
| 4,343,438 A | 8/1982 | Slikas et al. | 8,960,581 B1 | 2/2015 | Young |
| 4,352,774 A | 10/1982 | Hornberger | 8,998,120 B1 | 4/2015 | Young |
| 4,406,415 A | 9/1983 | Greer | 9,358,546 B1 | 6/2016 | Young |
| 4,519,551 A | 5/1985 | Ceurvorst | 9,566,584 B2 | 2/2017 | Young et al. |
| 4,558,826 A | 12/1985 | Martinek | D839,934 S * | 2/2019 | Young D15/123 |
| 4,729,516 A | 3/1988 | Williams, Jr. | 2002/0190148 A1 | 12/2002 | Roozeboom et al. |
| 4,795,103 A | 1/1989 | Lech | 2004/0017955 A1 | 1/2004 | Schillinger et al. |
| 4,856,170 A | 8/1989 | Kachik | 2006/0032958 A1 | 2/2006 | Young |
| 4,907,750 A | 3/1990 | Seifert | 2007/0023554 A1 | 2/2007 | Young |
| 4,915,310 A | 4/1990 | Stelk | 2009/0321546 A1 | 12/2009 | Plumb et al. |
| 5,002,233 A | 3/1991 | Williams | 2010/0025511 A1 | 2/2010 | Young |
| 5,072,888 A | 12/1991 | Stelk | 2010/0090047 A1 | 4/2010 | Willibald |
| 5,169,077 A | 12/1992 | Stelk | 2010/0213301 A1 | 8/2010 | Hoice et al. |
| 5,207,391 A | 5/1993 | Anderson | 2011/0042498 A1 | 2/2011 | Young et al. |
| 5,320,292 A | 6/1994 | Smith | 2016/0243554 A1 | 8/2016 | Young |
| 5,364,038 A | 11/1994 | Prew | | | |
| 5,377,919 A | 1/1995 | Rogers et al. | | | |
| 5,381,975 A | 1/1995 | Chon et al. | | | |
| 5,443,216 A | 8/1995 | Lajoie | | | |

OTHER PUBLICATIONS

- Rightway Manufacturing, "Hammers", <http://www.rwmfginc.com/products.aspx?gs=1>, pp. 1-3. Oct. 19, 2017.
- Watson, Stanley A. & Paul E. Ramstad, eds. (Corn: Chemistry and Technology, Chapter 11, American Association of Cereal Chemist, Inc. St. Paul, Minn.) 1987.

(56)

References Cited

OTHER PUBLICATIONS

“Tungsten Carbide Hardfacing”, http://tungstencarbidehardfacing.com/tungstencarbidehardfacing/index_tchf.php, Postalloy, 4 pages, accessed on Nov. 12, 2017.

“MIG Welding: The Basics for Mild Steel”, <https://www.millerwelds.com/resources/article-library/mig-welding-the-basic-for-mild-steel>, MillerWelds, 9 pages, accessed on Nov. 12, 2017.

“Jacobs Pentagon XTREME Hammer System”, <https://www.jacobscorp.com/t-pentagon.aspx>, access by Applicant in 2018.

* cited by examiner

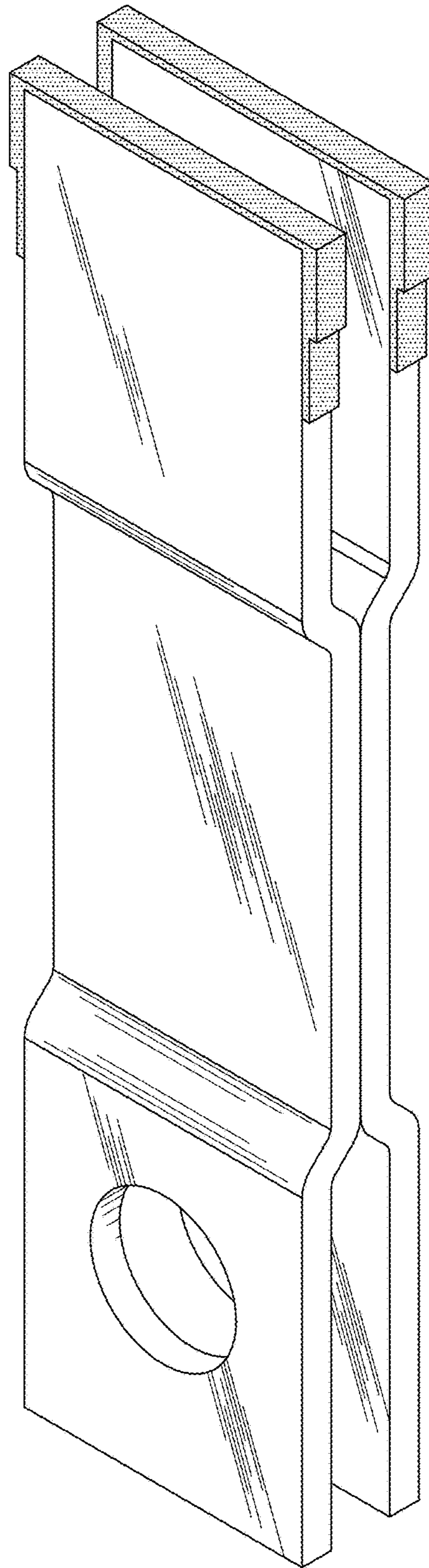

Fig. 1

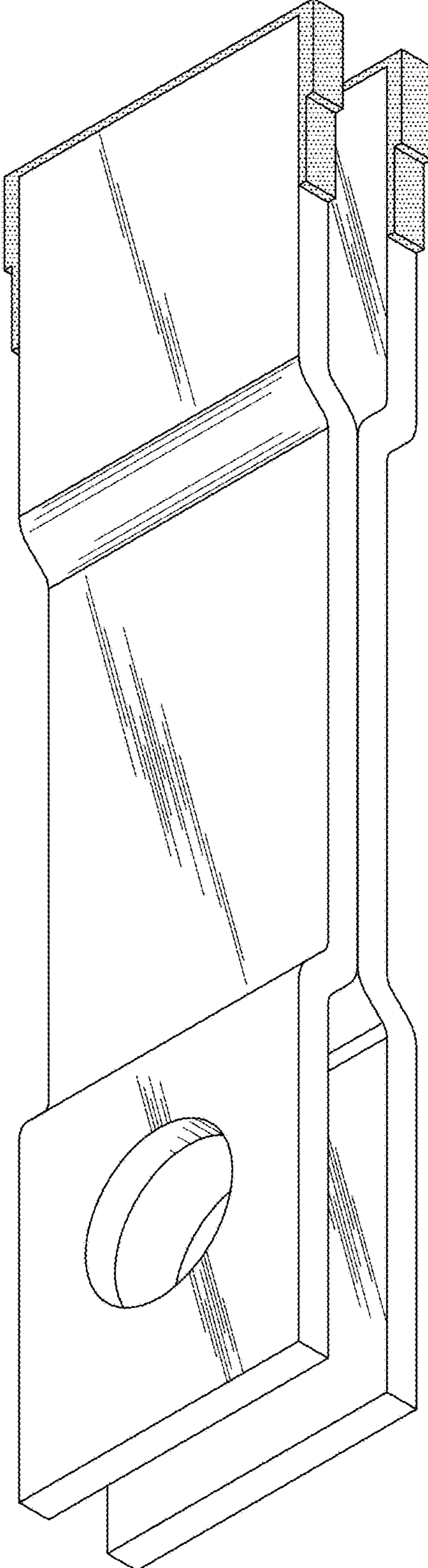

Fig. 2

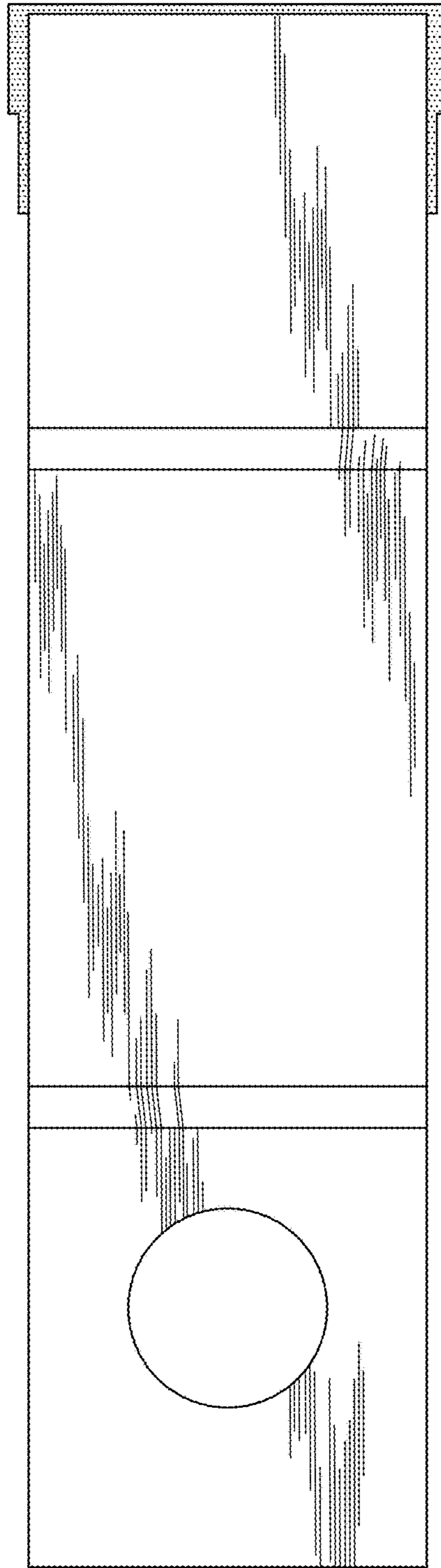

Fig. 3

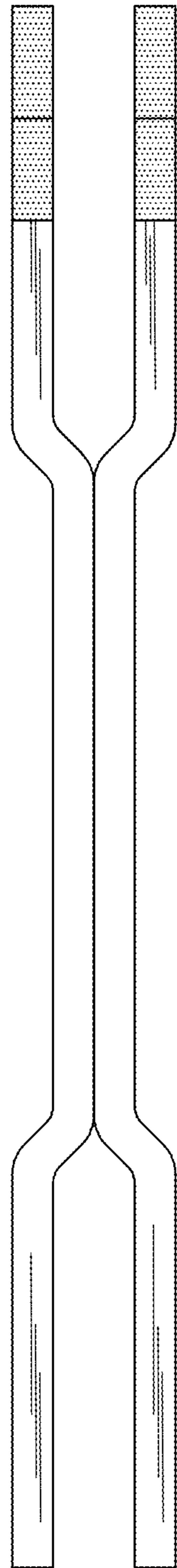

Fig. 4

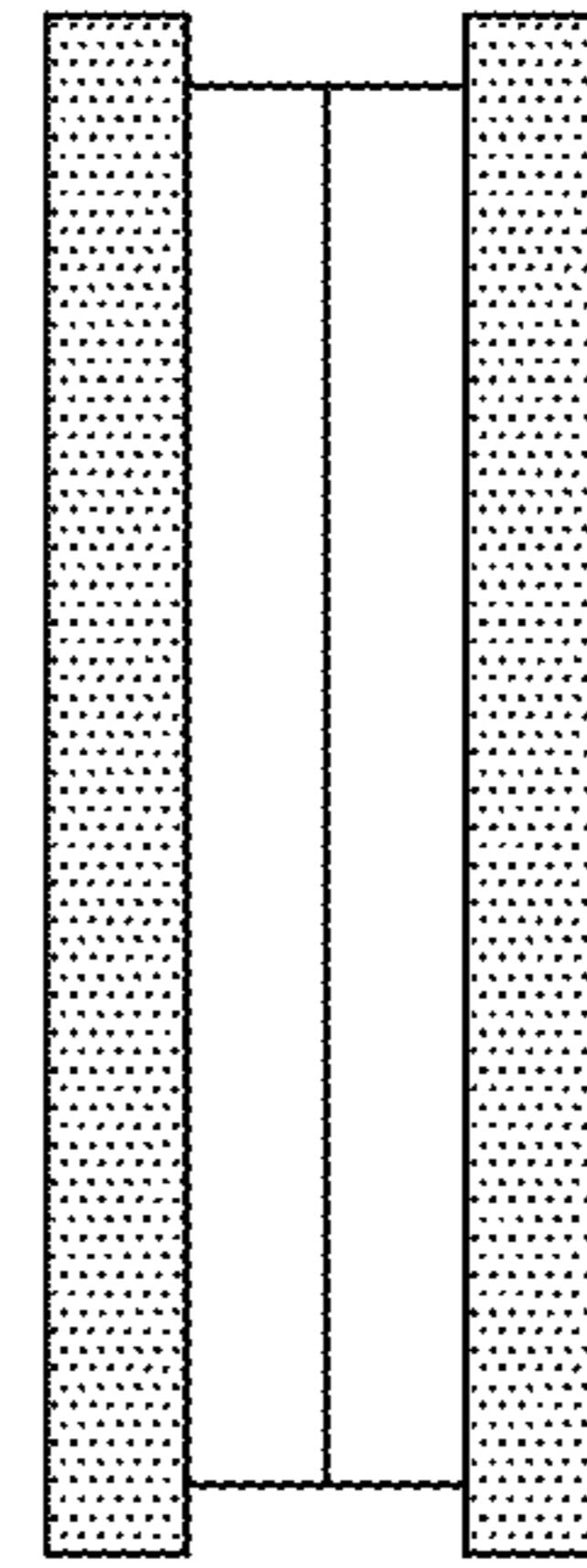

Fig. 5

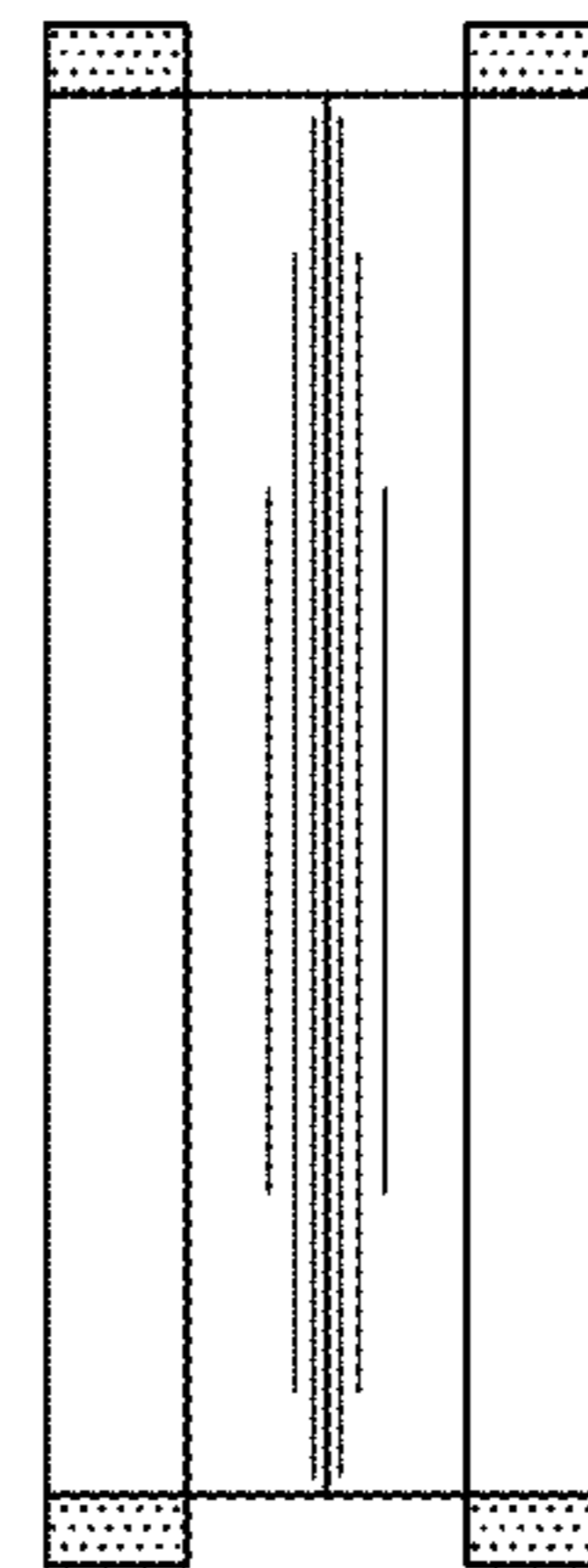

Fig. 6

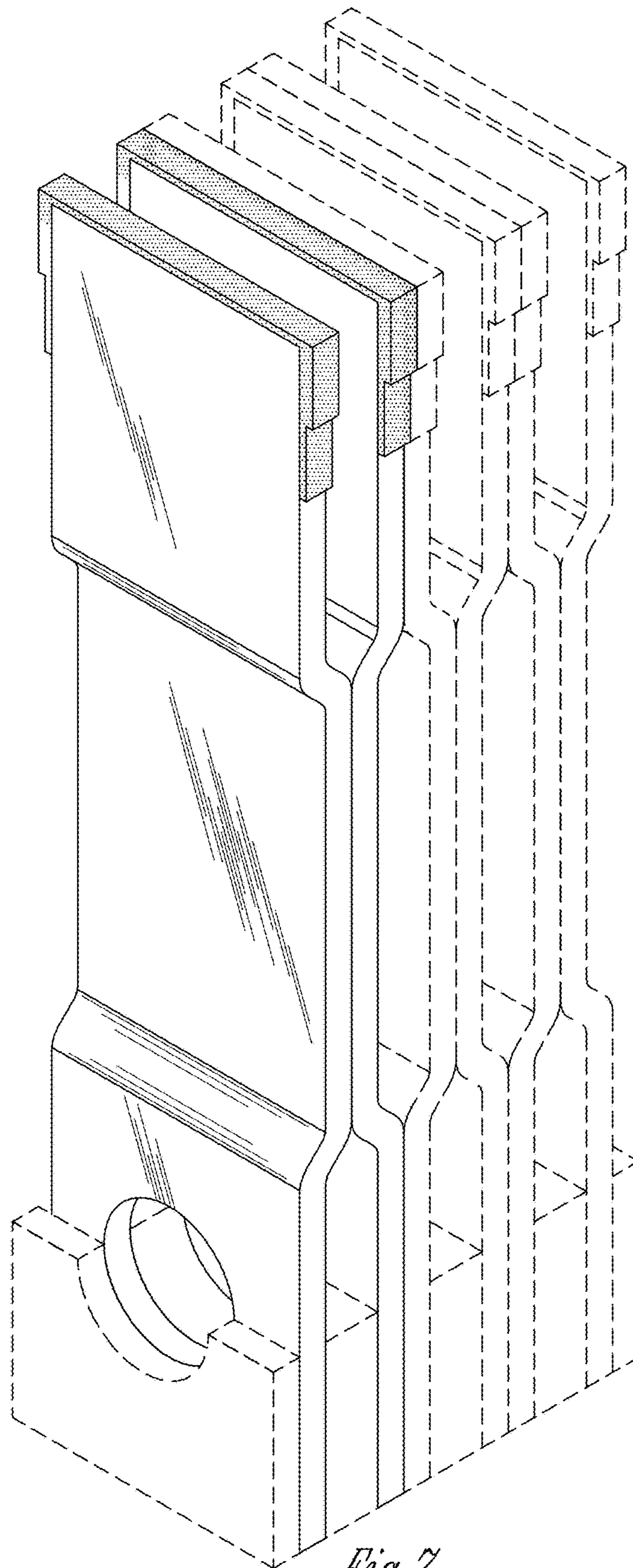

Fig. 7

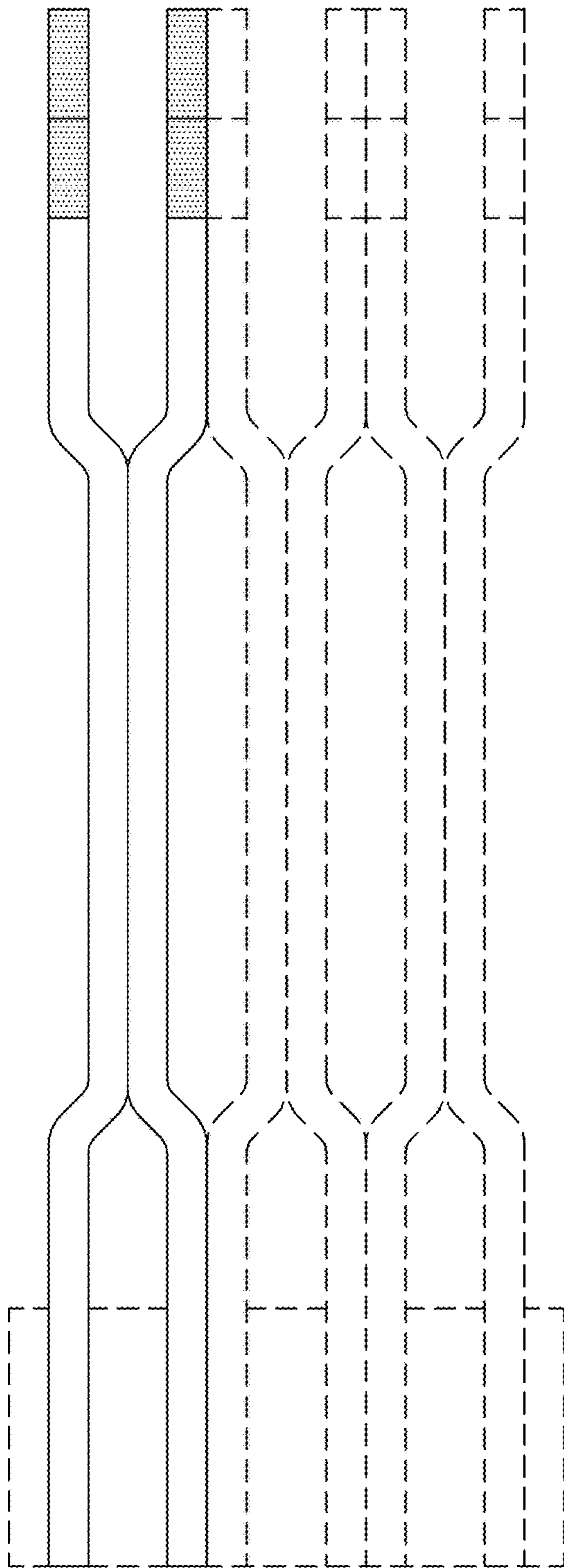

Fig. 8

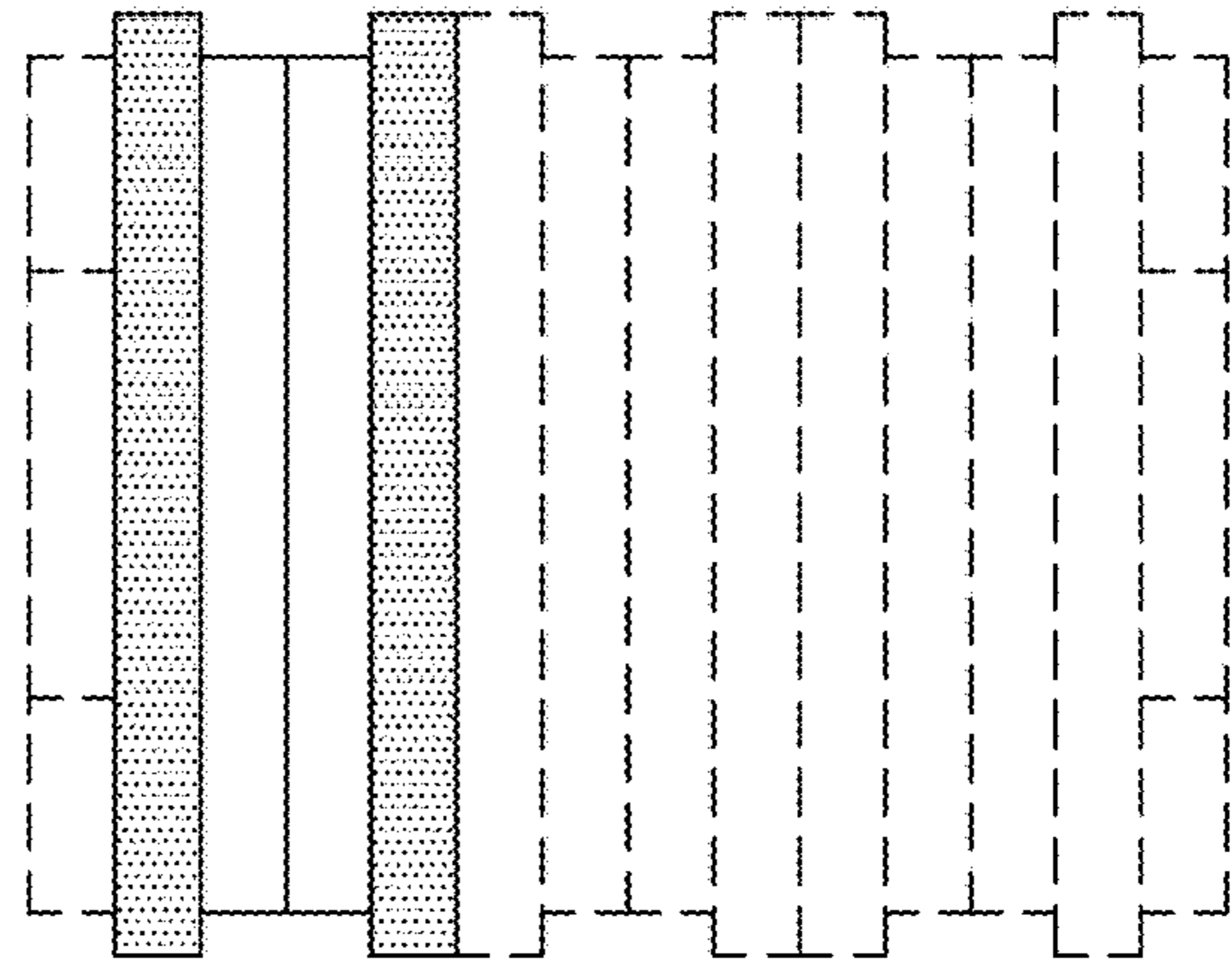

Fig. 9

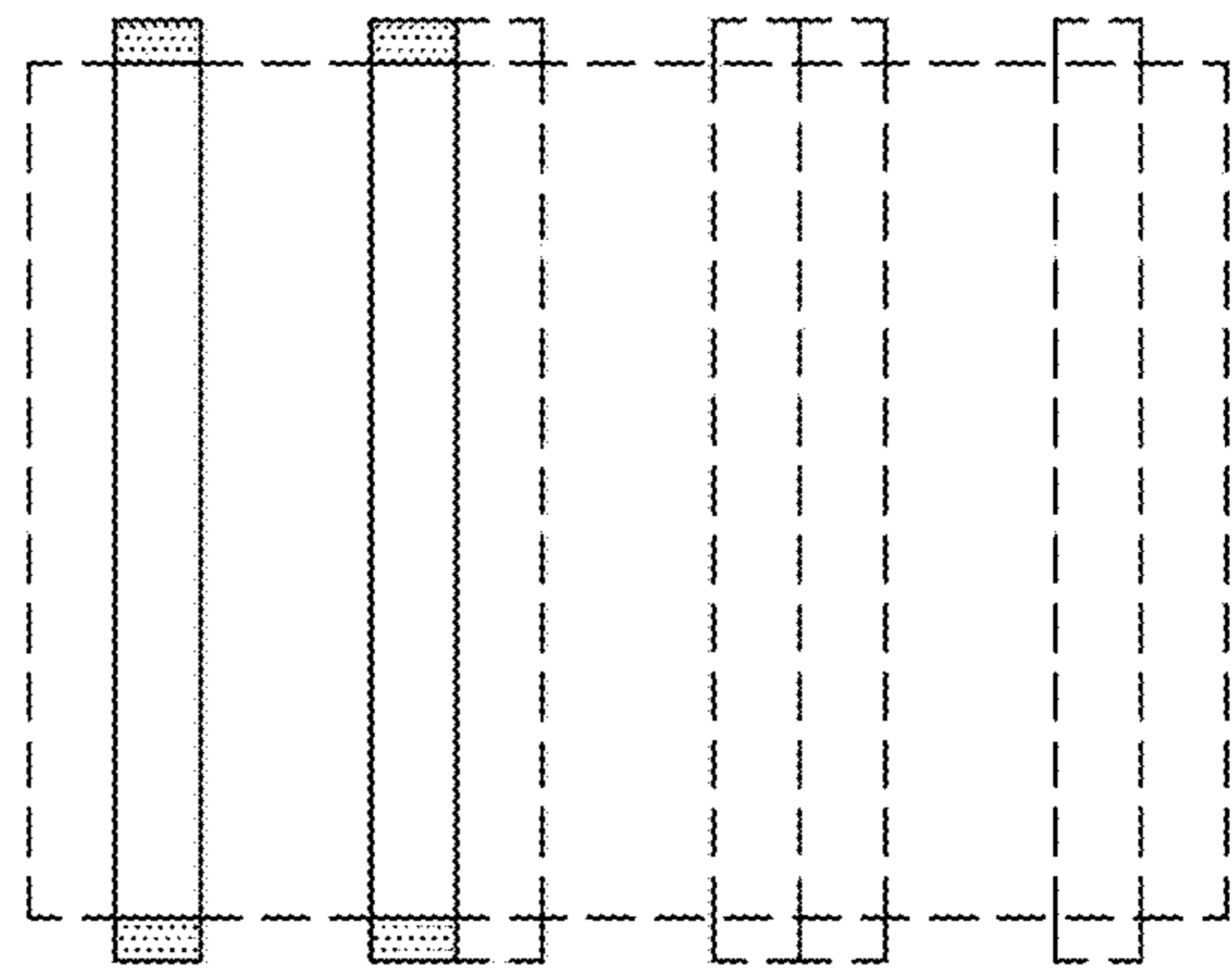

Fig. 10