



US00D856377S

(12) **United States Design Patent** (10) **Patent No.:** **US D856,377 S**
Ainge et al. (45) **Date of Patent:** **** Aug. 13, 2019**

(54) **LINK ASSEMBLY OF AN AGRICULTURAL GROUND ENGAGING CHAIN**

Primary Examiner — Mark A Goodwin

(71) Applicant: **HARD METALS AUSTRALIA PTY LIMITED**, Eastern Creek, NSW (AU)

(57) **CLAIM**

(72) Inventors: **Stephen Ainge**, Eastern Creek (AU);
Seyed Ali Heydarshahy, Eastern Creek (AU)

The ornamental design for the link assembly of an agricultural ground engaging chain, as shown and described.

(73) Assignee: **HARD METALS AUSTRALIA PTY LIMITED**, Eastern Creek, New South Wales (AU)

DESCRIPTION

(**) Term: **15 Years**

(21) Appl. No.: **29/644,427**

(22) Filed: **Apr. 17, 2018**

(30) **Foreign Application Priority Data**

Oct. 19, 2017 (AU) 201716364

(51) **LOC (12) Cl.** **15-03**

(52) **U.S. Cl.**
USPC **D15/28**

(58) **Field of Classification Search**
USPC D15/11, 17, 21, 27, 28, 29; 172/707,
172/747, 772, 772.5, 704, 708, 705, 720,
172/765, 579, 462, 572, 599, 627
(Continued)

(56) **References Cited**

U.S. PATENT DOCUMENTS

1,832,649 A * 11/1931 Oreind A01B 23/06
172/599

2,979,138 A 4/1961 Martensen
(Continued)

FOREIGN PATENT DOCUMENTS

AU 2007216912 4/2008
EE 01245 10/2014

(Continued)

FIG. 1 is a front isometric view of the design for link assembly of an agricultural ground engaging chain; FIG. 2 is a top rear isometric view of the design for link assembly of an agricultural ground engaging chain; FIG. 3 is a bottom rear isometric view of the design for link assembly of an agricultural ground engaging chain; FIG. 4 is a top view of the design for link assembly of an agricultural ground engaging chain; FIG. 5 is a bottom view of the design for link assembly of an agricultural ground engaging chain; FIG. 6 is a left side view of the design for link assembly of an agricultural ground engaging chain; FIG. 7 is a right side view of the design for link assembly of an agricultural ground engaging chain; FIG. 8 is front view of the design for link assembly of an agricultural ground engaging chain; FIG. 9 is a rear view of the design for link assembly of an agricultural ground engaging chain; FIG. 10 is a section view along the line AA-AA of FIG. 5 of the design for link assembly of an agricultural ground engaging chain; FIG. 11 is a section view along the line AC-AC of FIG. 4 of the design for link assembly of an agricultural ground engaging chain; FIG. 12 is a section view along the line AD-AD of FIG. 7 of the design for link assembly of an agricultural ground engaging chain; and, FIG. 13 is a section view along the line AB-AB of FIG. 6 of the design for link assembly of an agricultural ground engaging chain.

1 Claim, 9 Drawing Sheets

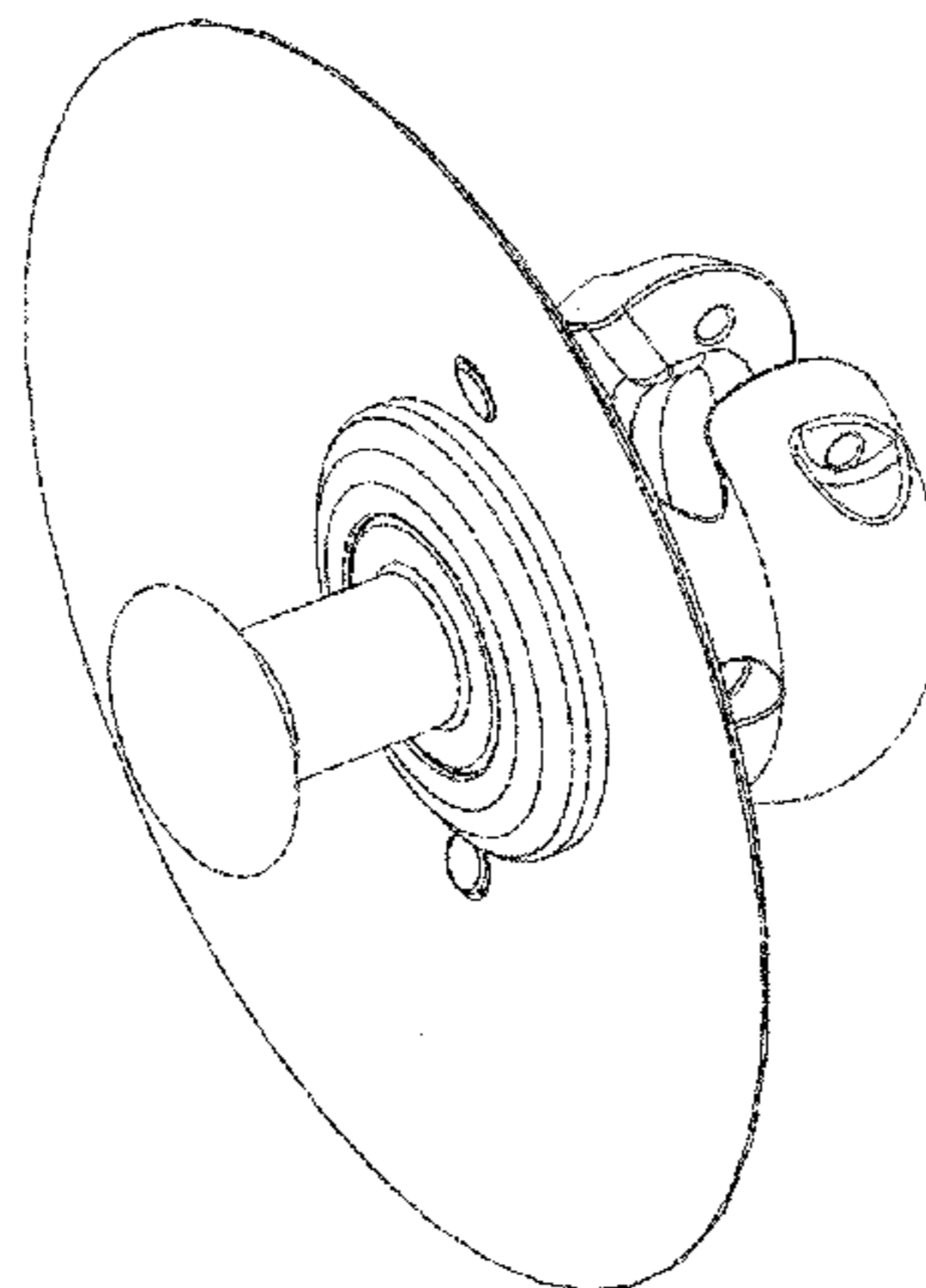

(58) **Field of Classification Search**

CPC A01B 39/20; A01B 19/02; A01B 35/24;
 A01B 35/225; A01B 35/00; A01B 23/02;
 A01B 23/00; A01B 23/06; A01B 21/00;
 A01B 21/08; A01B 21/04; A01B 31/00;
 A01B 71/04; A01B 15/16; A01B 15/18;
 B23K 1/0008

See application file for complete search history.

(56) **References Cited**

U.S. PATENT DOCUMENTS

4,083,413 A * 4/1978 Miller A01B 23/06
 172/601
 4,420,048 A * 12/1983 Peterson A01B 23/06
 172/568
 4,577,699 A * 3/1986 Rottinghaus A01B 61/04
 172/570
 D467,944 S * 12/2002 Stark D15/29
 7,607,489 B2 * 10/2009 Kelly A01B 23/06
 172/311
 D615,107 S * 5/2010 Kelly A01B 23/06
 D15/28

D615,108 S * 5/2010 Kelly A01B 23/06
 D15/28
 D623,500 S * 9/2010 Langner D8/349
 7,963,345 B1 * 6/2011 Hicks A01B 21/08
 172/579
 D694,284 S * 11/2013 Paterson D15/28
 D694,285 S * 11/2013 Paterson D15/28
 D700,219 S * 2/2014 Paterson D15/28
 8,662,195 B2 * 3/2014 Hicks A01B 21/08
 172/579
 D736,269 S * 8/2015 Paterson D15/29
 D742,725 S * 11/2015 Paterson D8/367
 D748,680 S * 2/2016 Ainge D15/29
 9,388,637 B2 * 7/2016 Ainge B28D 1/146
 D780,814 S * 3/2017 Ainge D15/29
 D821,451 S * 6/2018 Paterson D15/28
 2017/0013770 A1 * 1/2017 Ainge A01B 23/06

FOREIGN PATENT DOCUMENTS

GB 859317 1/1961
 WO WO 2015/131246 9/2015
 WO WO 2016/201486 12/2016

* cited by examiner

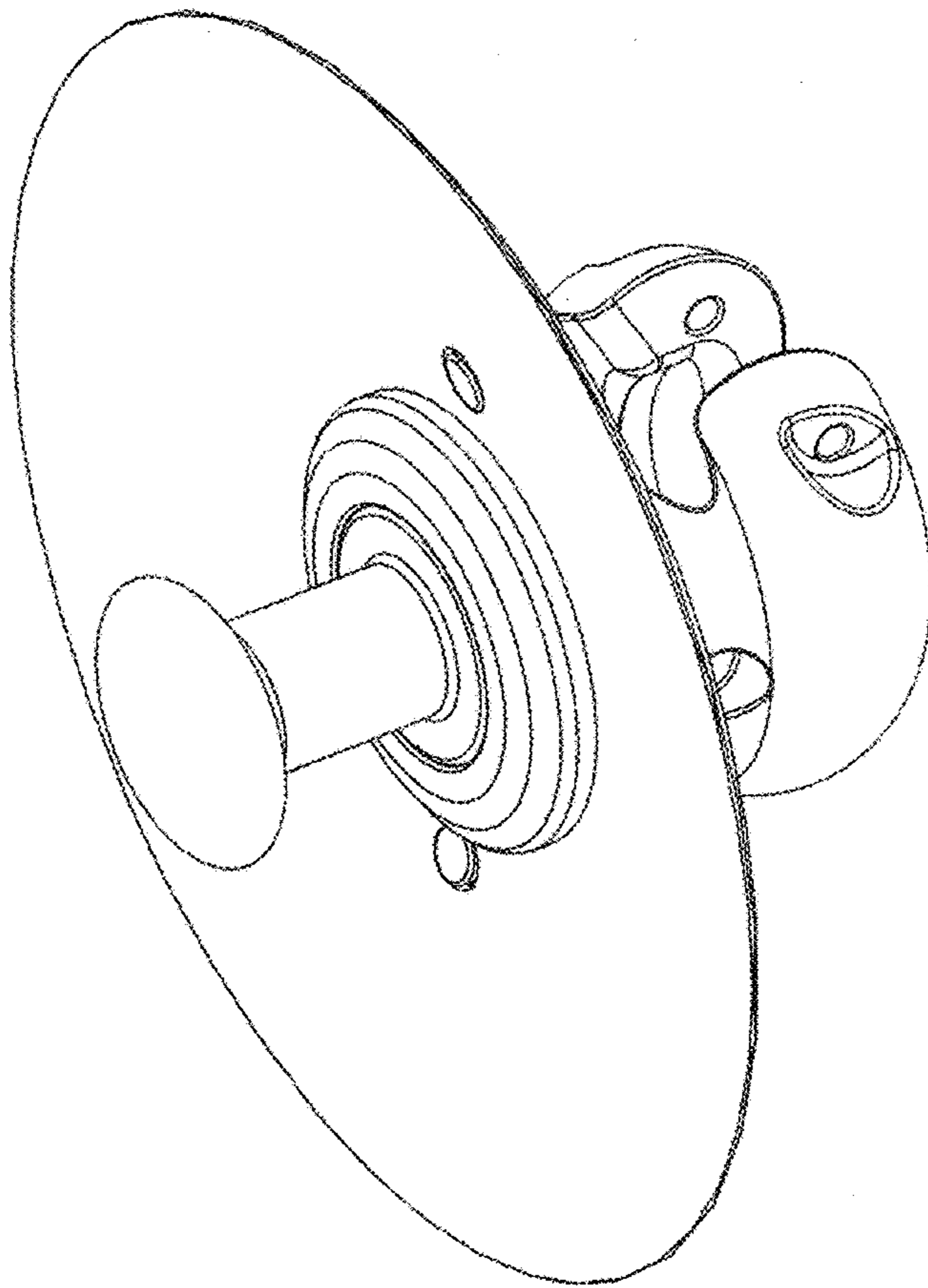

FIG. 1

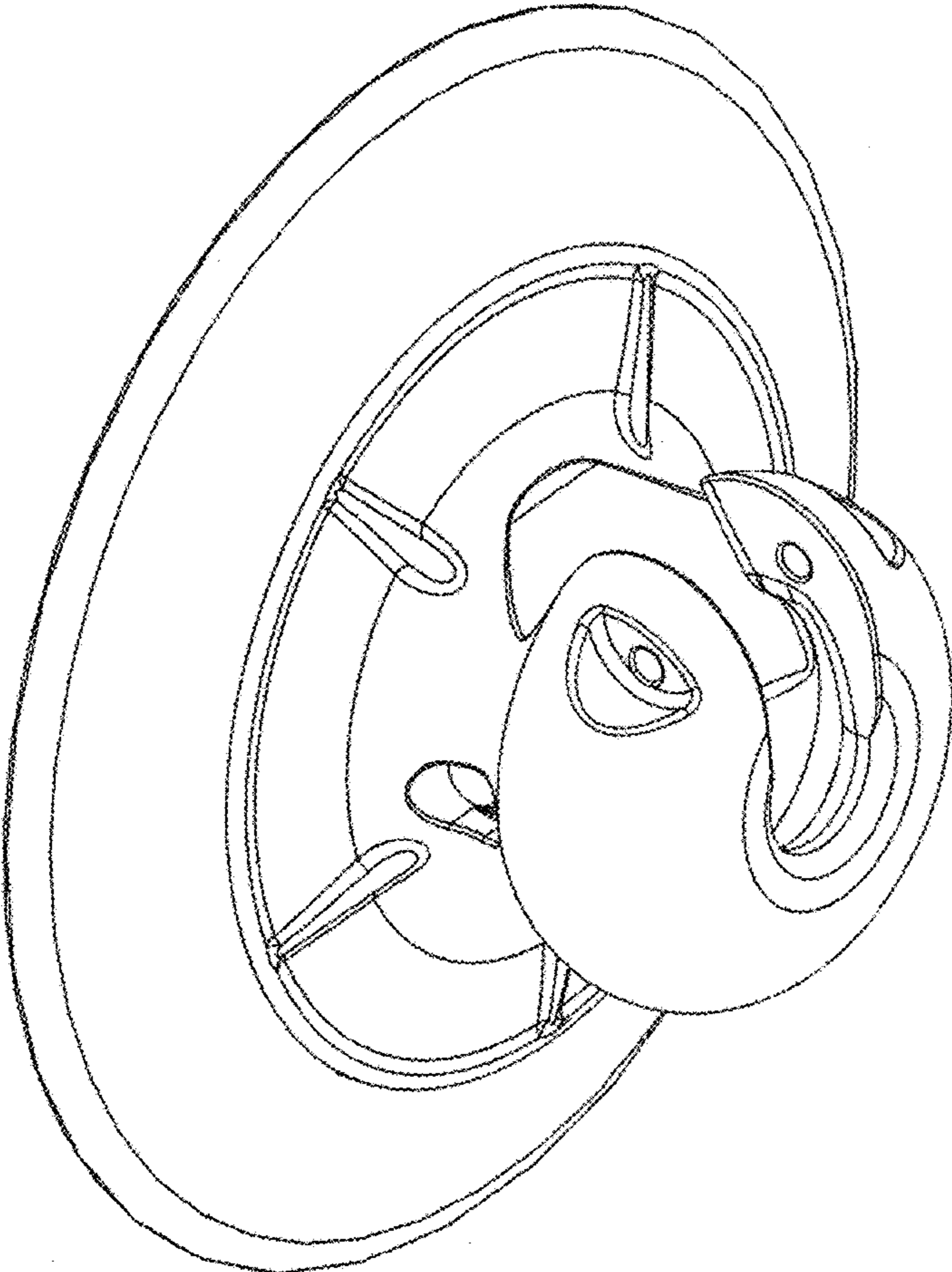

FIG. 2

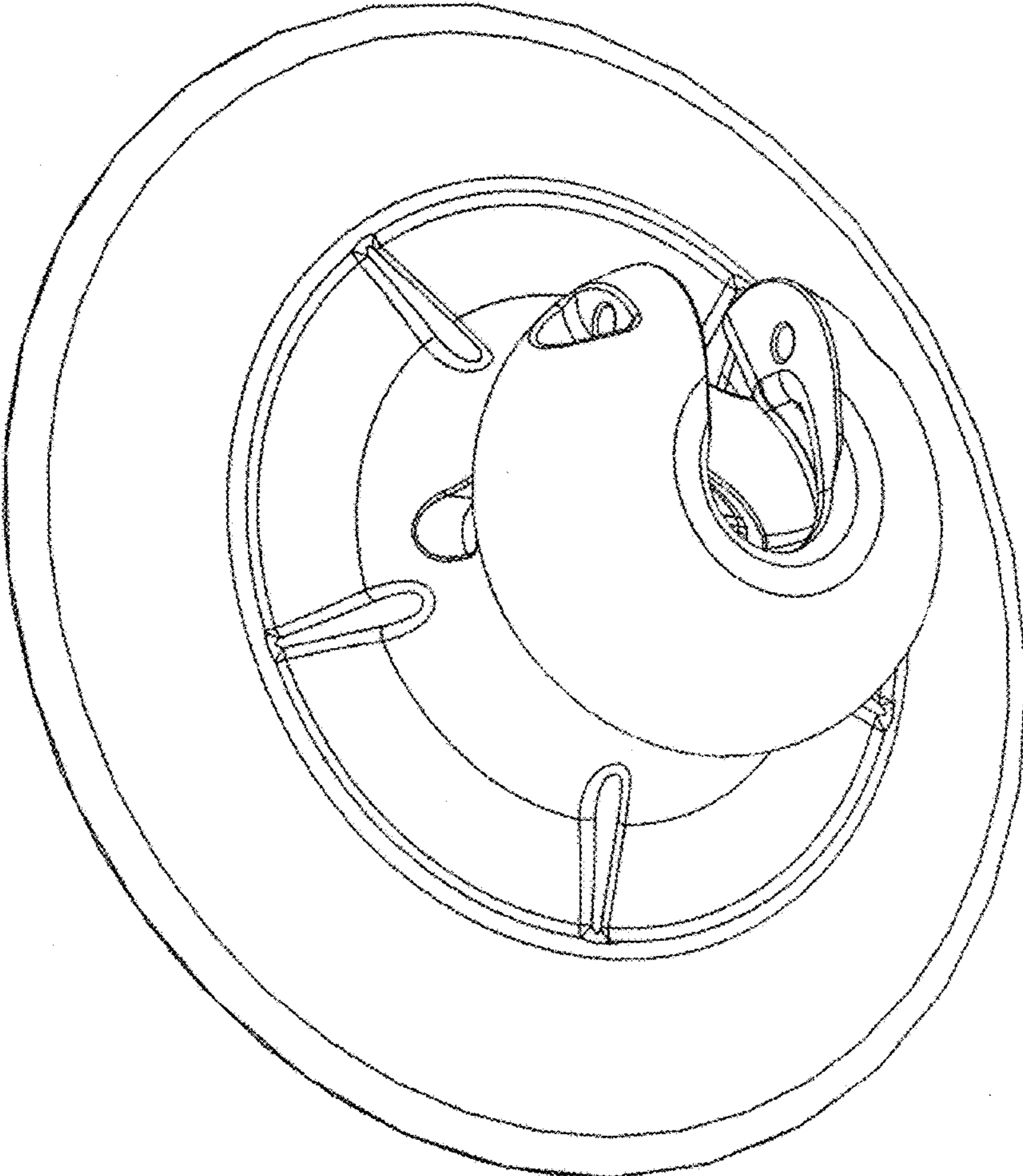

FIG. 3

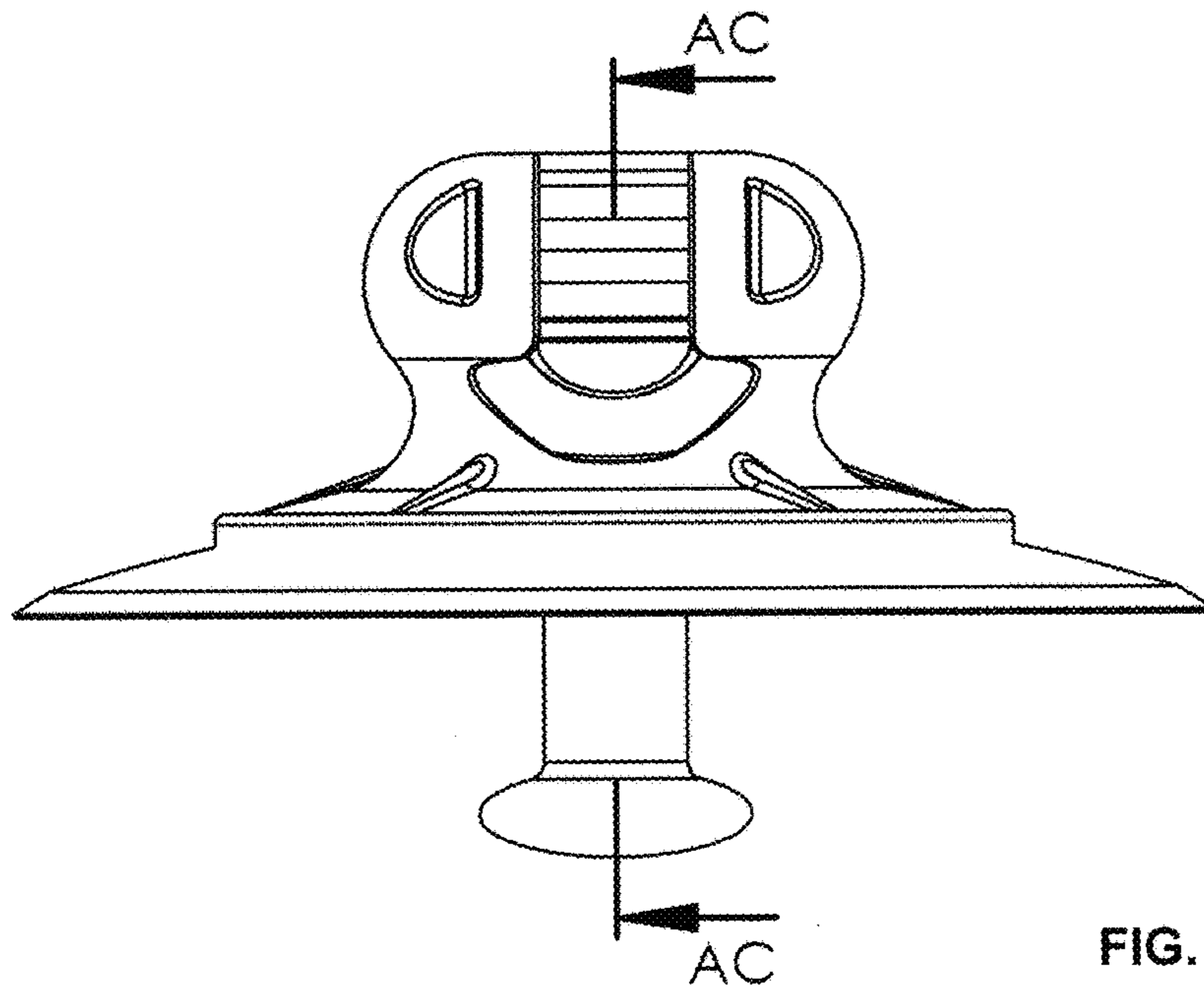

FIG. 4

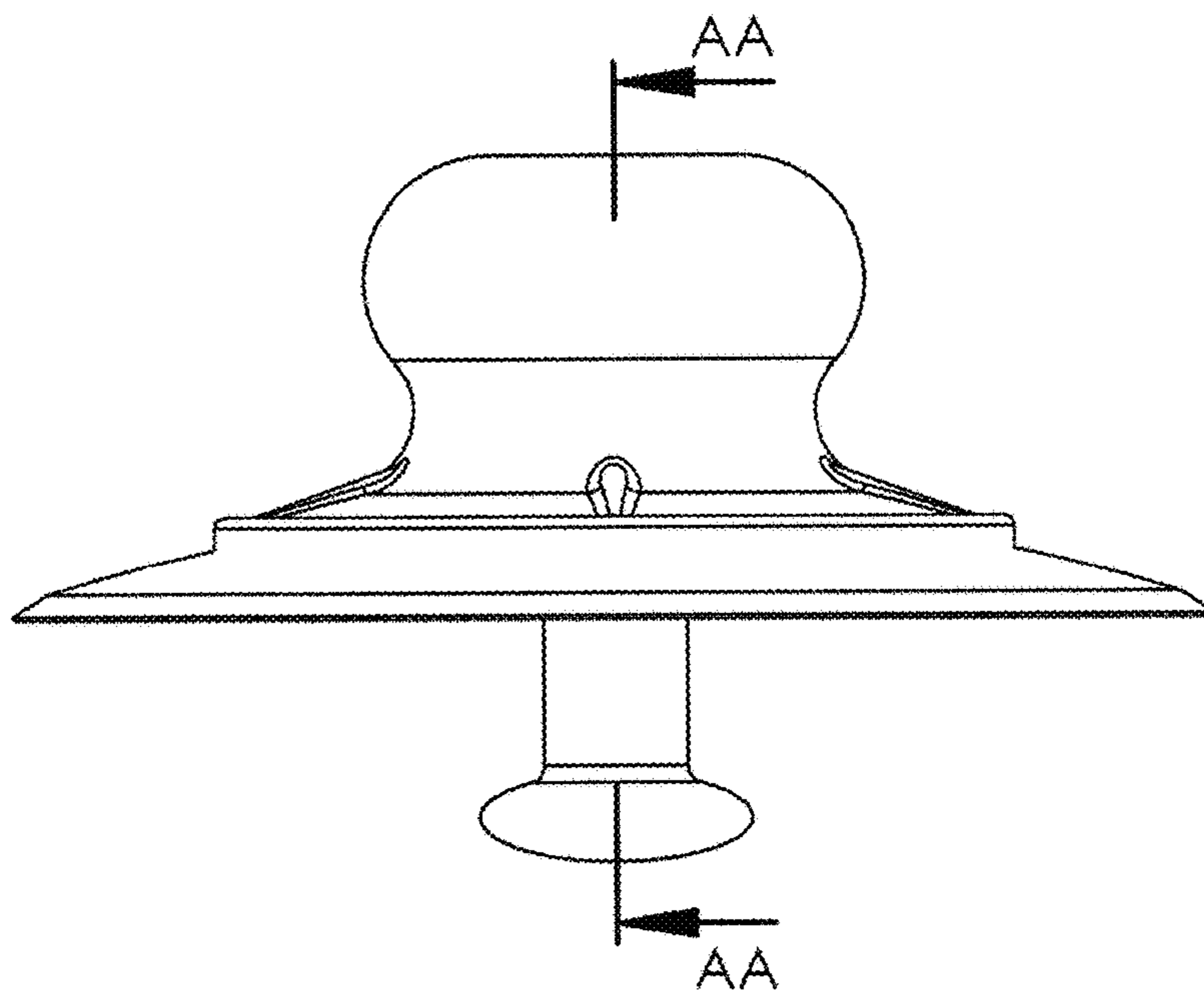

FIG. 5

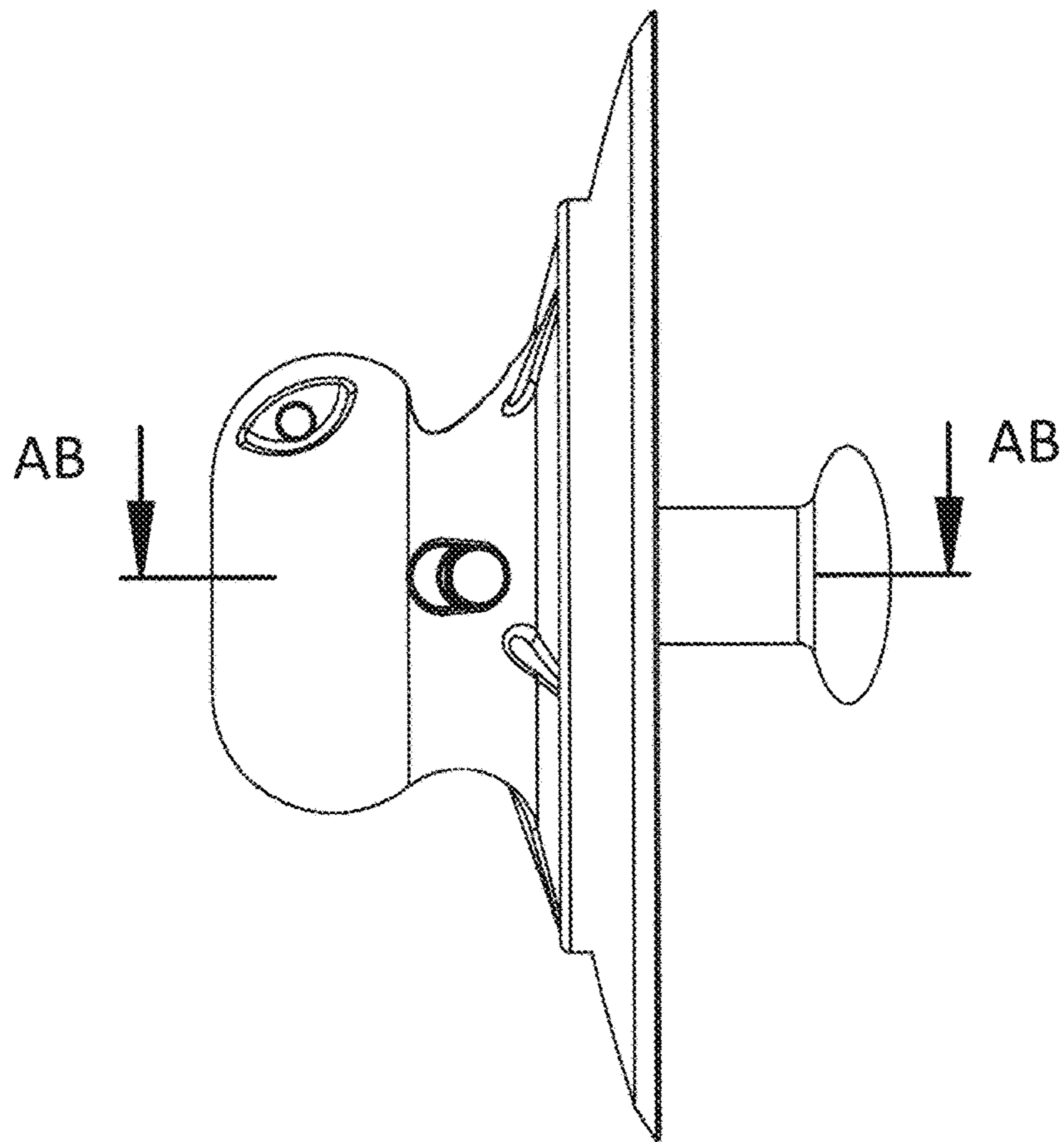

FIG. 6

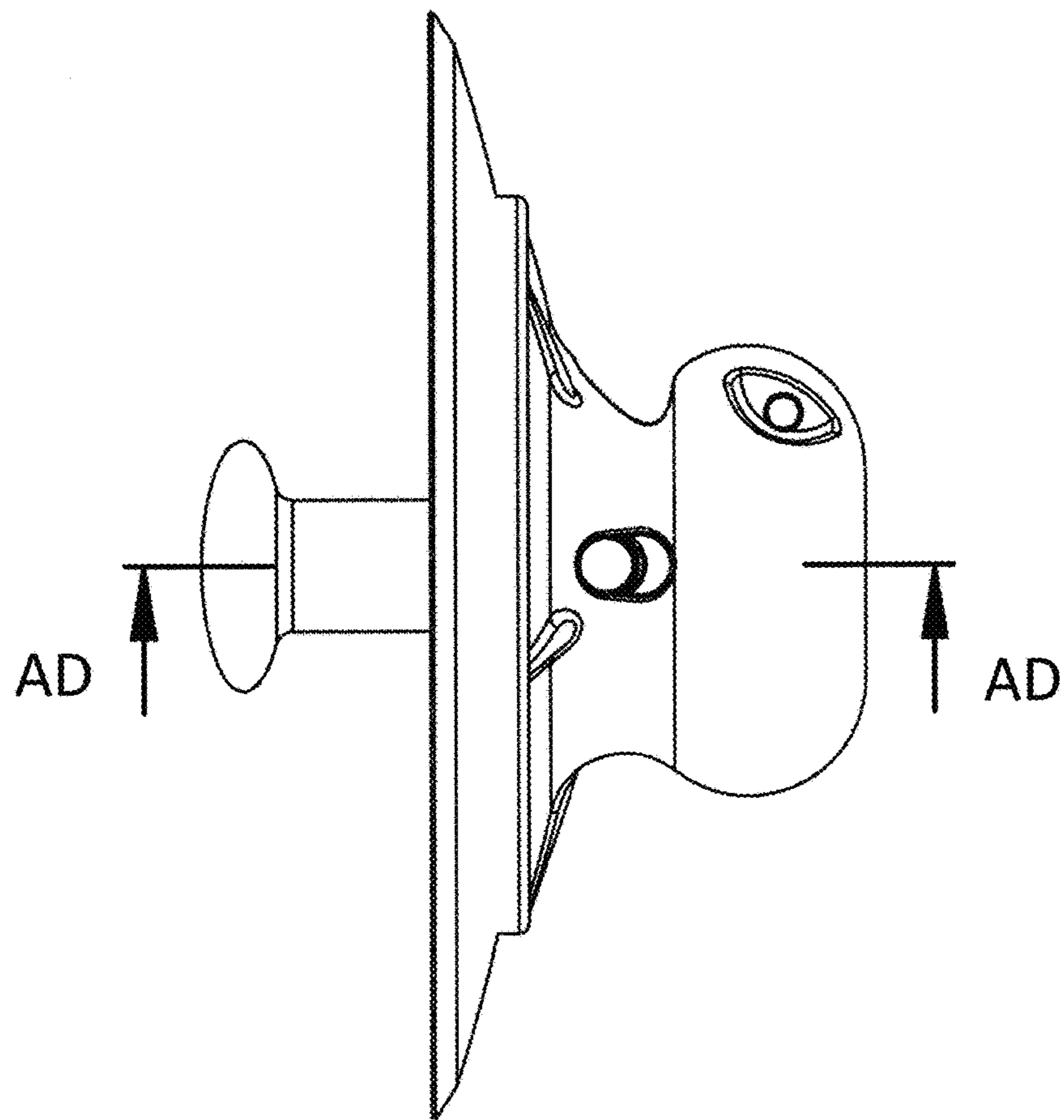

FIG. 7

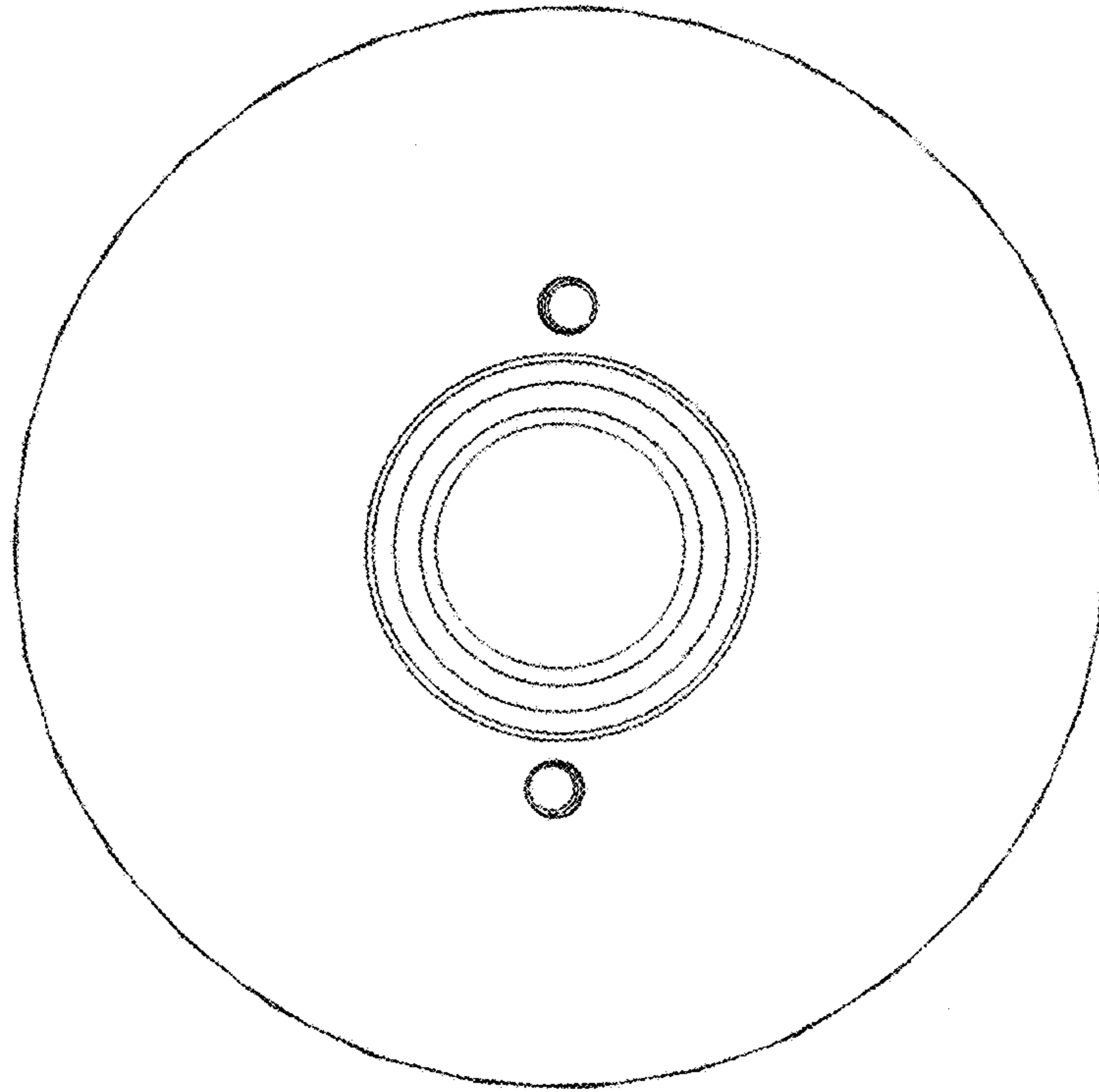

FIG. 8

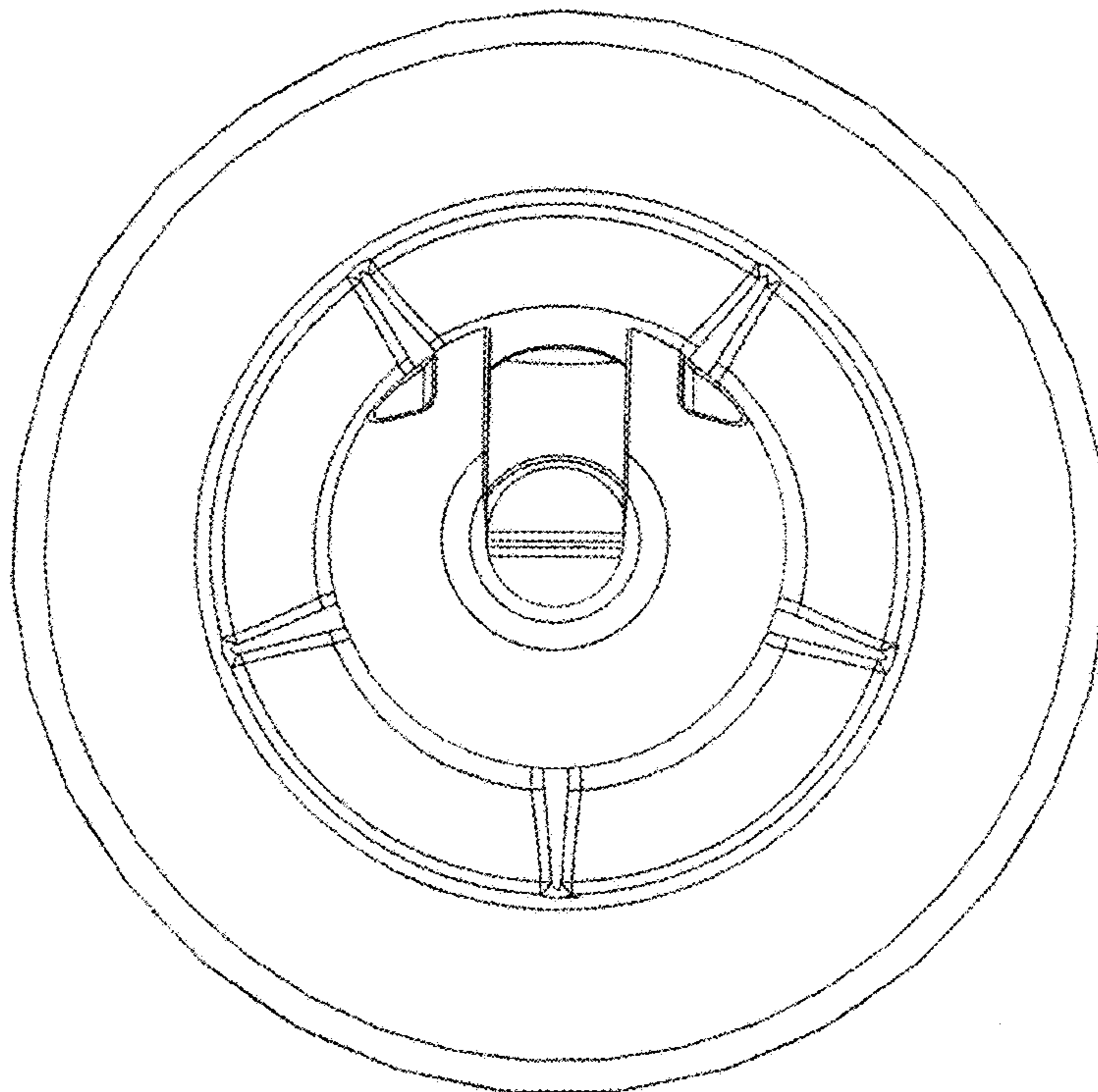

FIG. 9

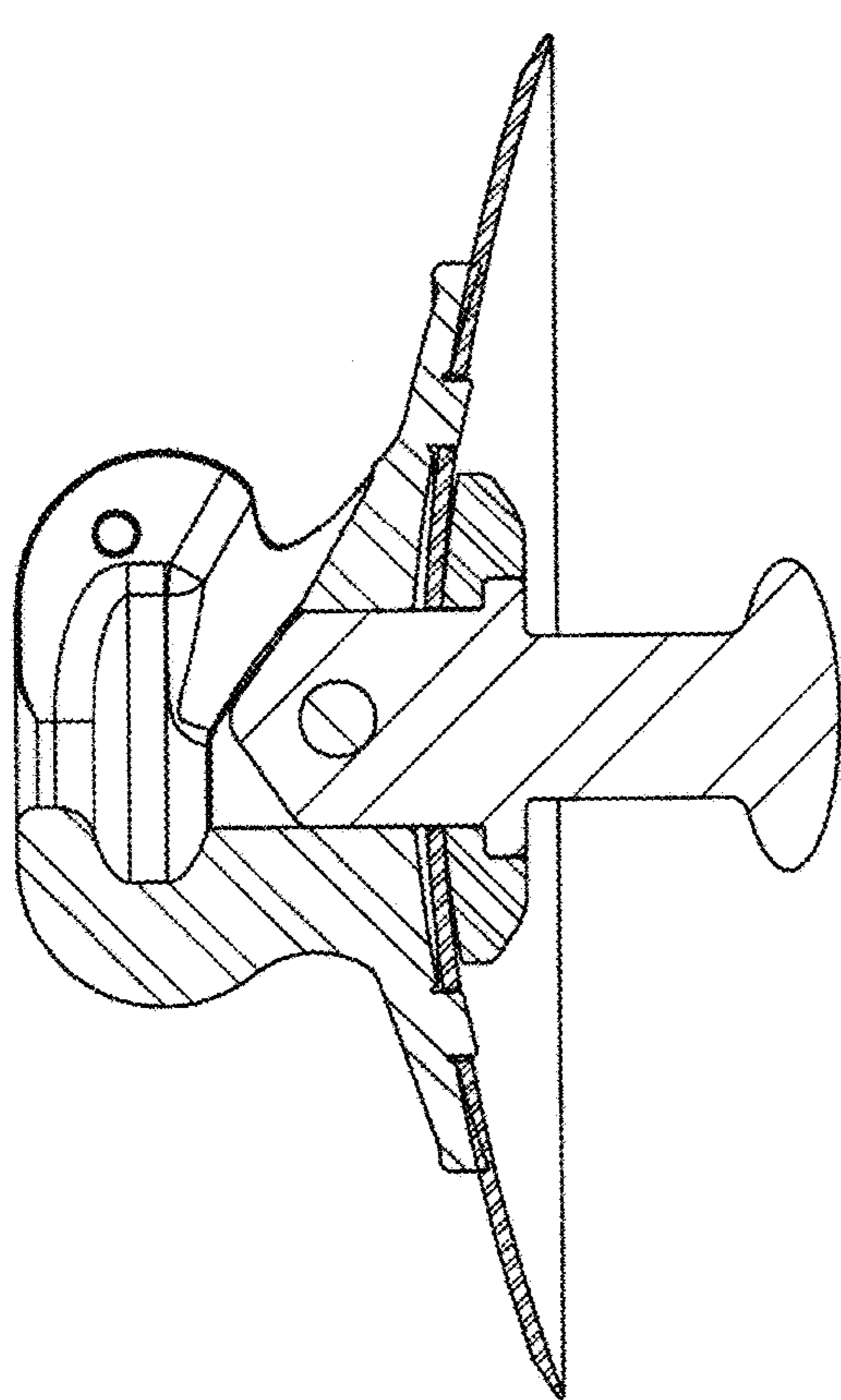

FIG. 10

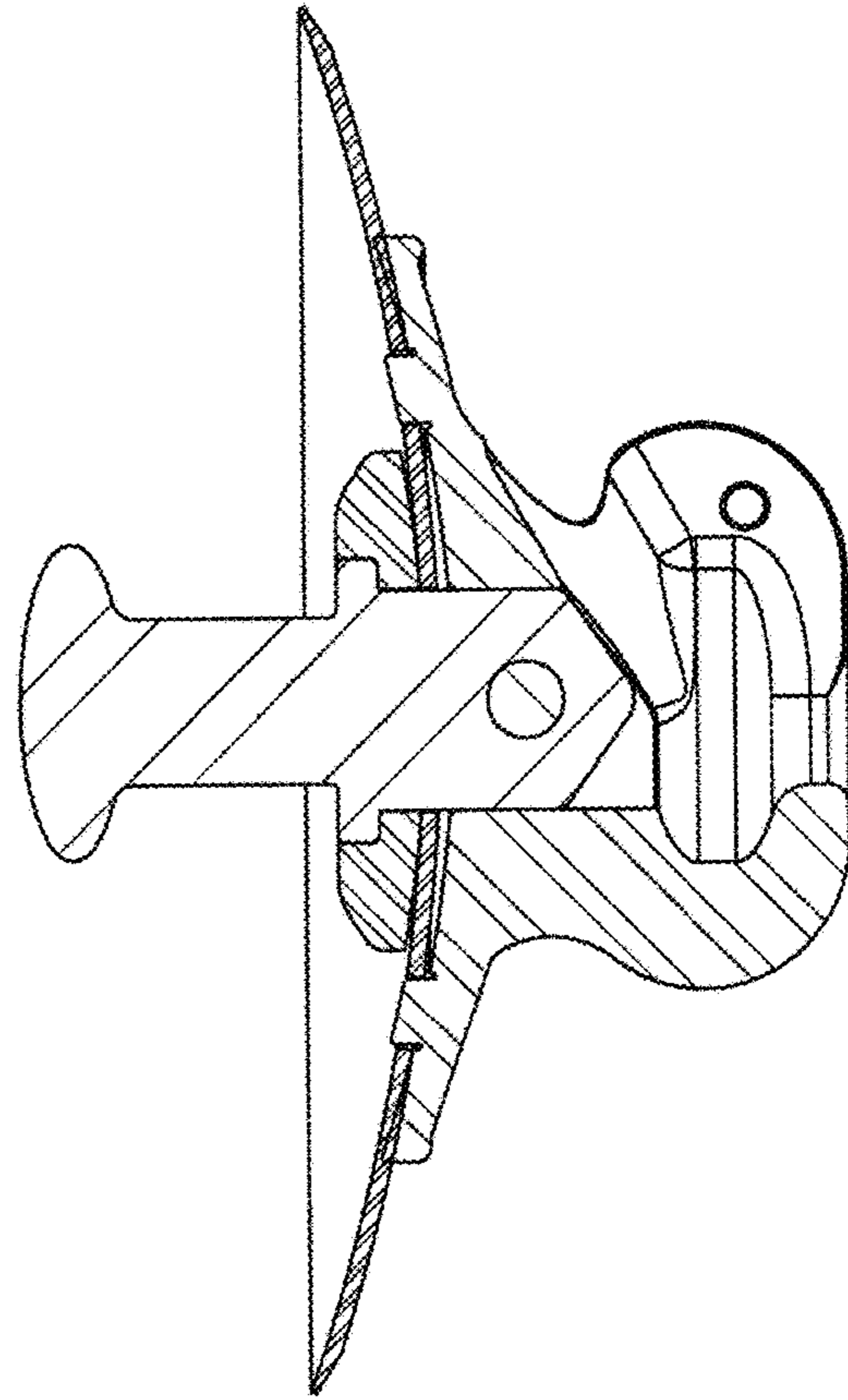

FIG. 11

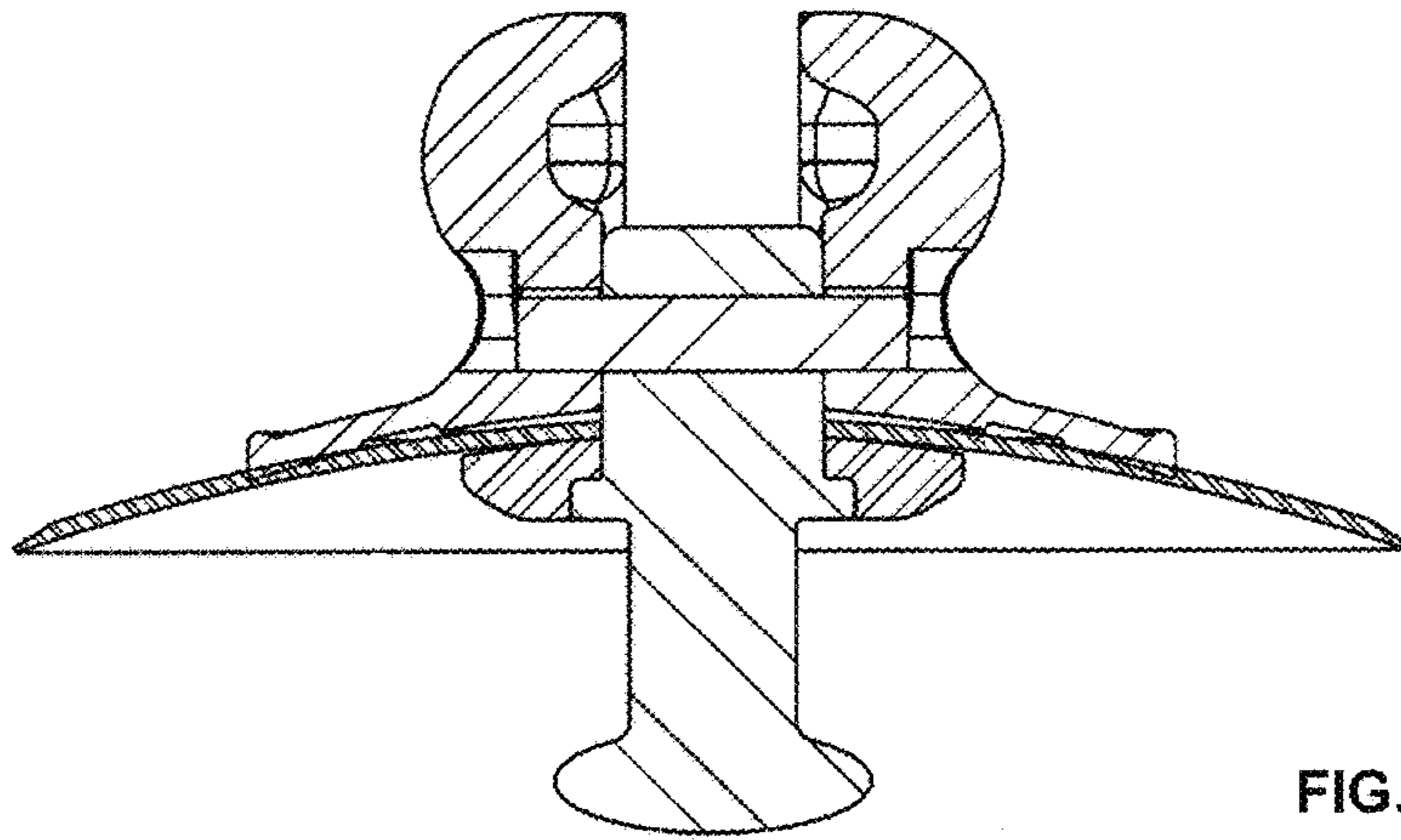

FIG. 12

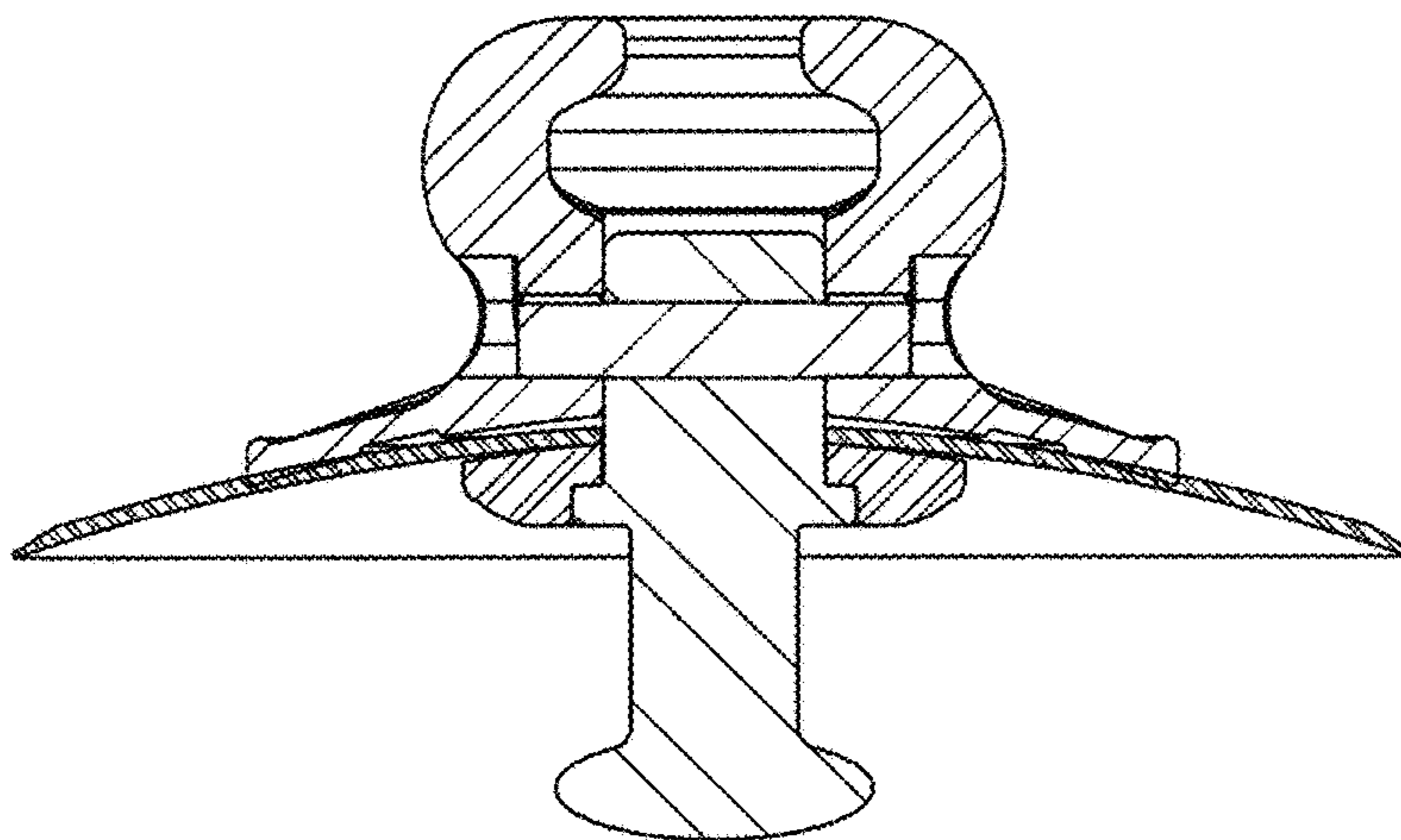

FIG. 13