



US00D856120S

(12) **United States Design Patent** (10) **Patent No.:** **US D856,120 S**
Diz et al. (45) **Date of Patent:** **** Aug. 13, 2019**

(54) **CONTAINER WHEEL**

(71) Applicant: **Travelpro BSI, Inc.**, Boca Raton, FL (US)

(72) Inventors: **Martin Diz**, Buffalo, NY (US); **Brian Chen**, New York, NY (US); **Alejo Verlini**, Buenos Aires (AR); **Alejandro Sarra**, Buenos Aires (AR); **Diego M. Saez-Gil**, Brooklyn, NY (US); **Tomas M. Pierucci**, Buenos Aires (AR)

(73) Assignee: **Travelpro BSI, Inc.**, Boca Raton, FL (US)

(**) Term: **15 Years**

(21) Appl. No.: **29/614,486**

(22) Filed: **Aug. 18, 2017**

Related U.S. Application Data

(62) Division of application No. 29/525,533, filed on Apr. 30, 2015, now Pat. No. Des. 795,045.

(51) **LOC (12) Cl.** **08-05**

(52) **U.S. Cl.**
USPC **D8/375**

(58) **Field of Classification Search**

USPC D8/375, 374, 382, 354, 377, 358;
D24/183; D21/424, 425, 533-536;
D12/19; D3/318, 279, 271.12; D34/14,
D34/19, 24, 25, 27; D25/48.4
CPC B60B 33/0002; B60B 33/00; Y10T 16/18;
Y10T 16/209; Y10T 16/216; A47B 91/06;
A47C 7/006; E05D 15/0678; F16C
13/006; F16C 2326/02; F16C 33/4652;
F16C 33/498; F16C 33/74; Y10S 297/04

See application file for complete search history.

(56) **References Cited**

U.S. PATENT DOCUMENTS

D198,901 S * 8/1964 Bruckner D8/375
3,331,460 A 7/1967 Bacon

(Continued)

FOREIGN PATENT DOCUMENTS

WO WO-2007/063302 A1 6/2007
WO WO-2013/126459 A2 8/2013

(Continued)

OTHER PUBLICATIONS

European Search Report issued in EP 15798823.9 (Dec. 12, 2017).

(Continued)

Primary Examiner — Eliza Z Bennett-Hattan

(74) *Attorney, Agent, or Firm* — Akerman LLP

(57) **CLAIM**

We claim the ornamental design for a container wheel, as shown and described.

DESCRIPTION

FIG. 1 is a top perspective view of a container wheel without the attachment assembly, for clarity of disclosure;

FIG. 2 is a side view of the container wheel without the attachment assembly, for clarity of disclosure;

FIG. 3 is a front view of the container wheel without the attachment assembly, for clarity disclosure;

FIG. 4 is a top view of the container wheel without the attachment assembly, for clarity of disclosure;

FIG. 5 is a top perspective view of the container wheel in an environment of use.

FIG. 6 is a side view of multiple container wheels arranged with a container according to one embodiment; and

FIG. 7 is a front view of the container wheel in an alternative environment of use; and,

FIG. 8 is a top perspective view of the container wheel in an alternative environment of use.

1 Claim, 5 Drawing Sheets

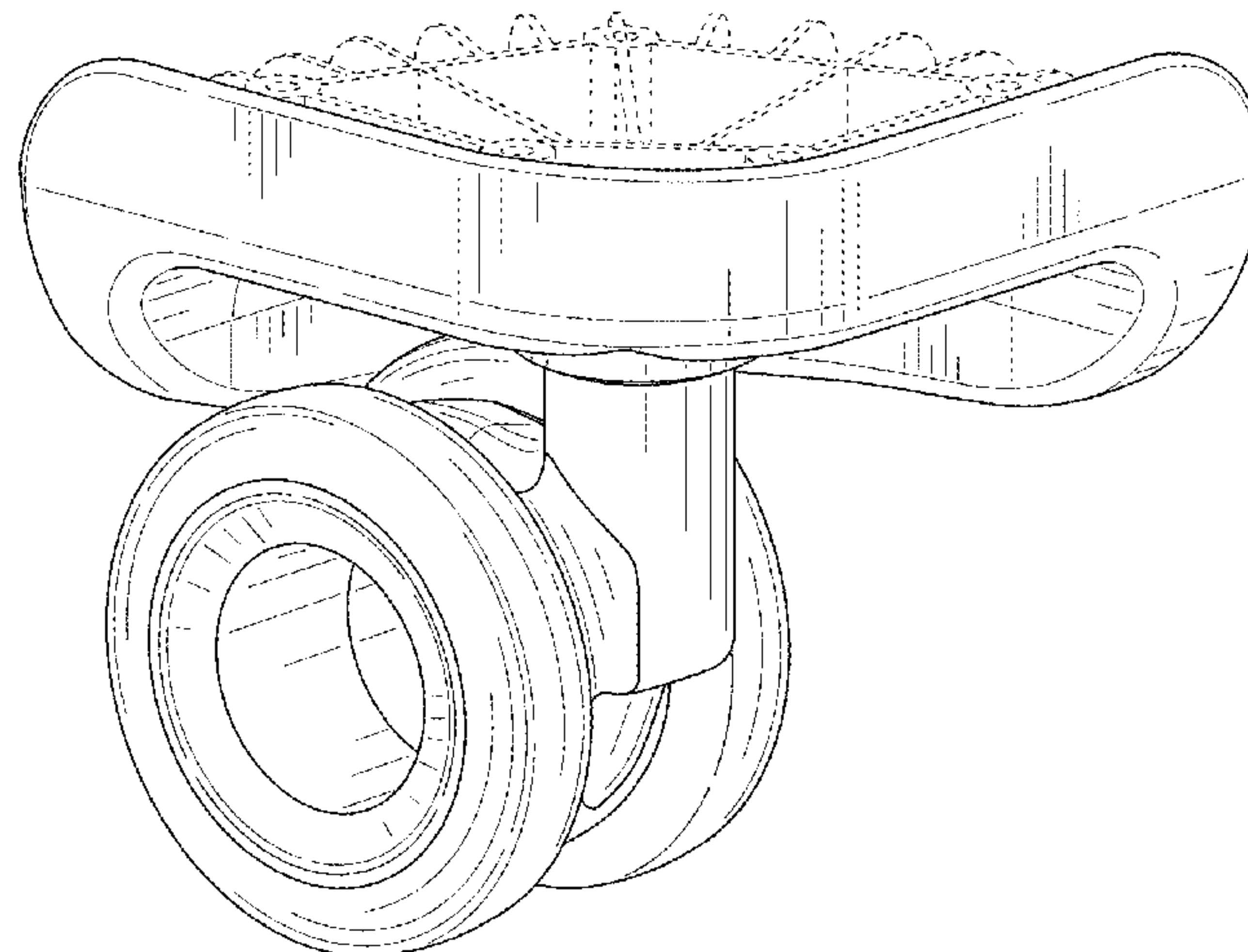

(56)

References Cited

U.S. PATENT DOCUMENTS

3,733,744 A 5/1973 Hiltpold et al.
 D239,433 S * 4/1976 Sugawara D8/375
 D245,313 S * 8/1977 Koepke D8/375
 4,404,707 A 9/1983 Walker
 4,671,524 A 6/1987 Haubenwallner
 4,773,889 A 9/1988 Rosenwinkel et al.
 D355,586 S * 2/1995 Wang D8/375
 5,568,671 A 10/1996 Harris et al.
 D383,604 S 9/1997 King
 D392,552 S * 3/1998 Miskill D8/375
 5,762,405 A 6/1998 Dempsey
 5,833,324 A 11/1998 Conradsson
 D401,844 S * 12/1998 Klippert, Jr. D8/375
 5,894,902 A 4/1999 Cho
 D425,301 S 5/2000 Sagol
 6,092,615 A 7/2000 Pusch et al.
 D428,698 S 8/2000 Cheng
 6,125,972 A 10/2000 French et al.
 6,139,040 A 10/2000 Dempsey
 D434,224 S 11/2000 Tiramani
 D435,967 S 1/2001 Tiramani
 D438,005 S 2/2001 Tiramani
 D440,764 S 4/2001 Cheng
 D454,430 S 3/2002 Sijmons
 6,362,728 B1 3/2002 Lace et al.
 D463,663 S 10/2002 Magana
 6,502,669 B1 1/2003 Harris
 D479,651 S 9/2003 Shen
 D485,681 S 1/2004 Fenton
 6,748,623 B1 6/2004 Tsai
 7,150,070 B2 12/2006 Donakowski
 7,337,862 B1 3/2008 Greenley et al.
 7,358,449 B2 4/2008 Hannon
 D572,577 S * 7/2008 Hatton D8/375
 D576,868 S * 9/2008 Minamiura D8/375
 D604,953 S 12/2009 Chu
 7,916,025 B2 3/2011 Locker et al.
 D639,149 S * 6/2011 Schioppa D8/375
 8,068,023 B2 11/2011 Dulin
 D659,395 S 5/2012 Sijmons
 8,375,515 B2 2/2013 Hozumi et al.
 8,485,329 B1 7/2013 Roy
 8,602,176 B2 12/2013 Khuu
 D701,753 S * 4/2014 Kubota D8/375
 D719,730 S 12/2014 Marabotto
 D720,928 S 1/2015 Roncato
 D722,771 S 2/2015 Wu
 D728,236 S 5/2015 Virassamy
 D730,050 S 5/2015 Hogan
 D740,558 S 10/2015 Liao
 D743,168 S 11/2015 Niu
 9,392,411 B1 7/2016 Al-Yousif
 D767,893 S 10/2016 Diz et al.
 D779,211 S 2/2017 Diz et al.
 D795,045 S 8/2017 Diz et al.
 2005/0081329 A1 4/2005 Tsai
 2007/0131462 A1 6/2007 Hemsley
 2007/0186373 A1 8/2007 Melara
 2008/0163455 A1 7/2008 Tsai
 2010/0306962 A1 12/2010 Breyer et al.
 2012/0152677 A1 6/2012 Lu
 2013/0214909 A1 8/2013 Meijers et al.
 2013/0255335 A1 10/2013 Jonely
 2013/0326844 A1 12/2013 Stoehr
 2014/0131156 A1 5/2014 Farrelly
 2014/0139334 A1 5/2014 Dubarry
 2014/0166416 A1 6/2014 Krulik

2014/0265359 A1 9/2014 Cheng
 2014/0283335 A1 9/2014 Meersschaert
 2015/0014108 A1 1/2015 Vecellio
 2015/0021132 A1 1/2015 Sijmons
 2015/0348347 A1 12/2015 Diz et al.
 2016/0171568 A1 6/2016 Cao
 2016/0328900 A1 11/2016 Yong et al.
 2017/0100961 A1 4/2017 Diz et al.
 2017/0103598 A1 4/2017 Diz et al.

FOREIGN PATENT DOCUMENTS

WO WO-2014/073791 A1 5/2014
 WO WO-2014/073971 A1 5/2015
 WO WO-2015/183949 A1 12/2015

OTHER PUBLICATIONS

Final Office Action issued in U.S. Appl. No. 15/388,413, dated (Nov. 1, 2017).
 Final Office Action issued in U.S. Appl. No. 15/389,044 dated (Mar. 12, 2018).
 Non-Final Office Action issued in Design U.S. Appl. No. 29/525,533 dated (Feb. 7, 2017).
 Final Office Action issued in U.S. Appl. No. 14/722,980 dated (Sep. 29, 2017).
 Designboom, “Bluesmart is a Smart Connected Carry-on Suitcase with Built-in Battery” Accessed on Apr. 5, 2016. Posted on Oct. 21, 2014, 19 pages. (<http://www.designboom.com/technology/bluesmart-smart-connected-suitcase-10-21-2014>).
 International Preliminary Report On Patentability dated Dec. 8, 2016, PCT/US2015/032667, filed on May 27, 2015, 9 pages.
 International search report dated Oct. 19, 2015, for PCT Application No. PCT/US2015/032667, filed on May 27, 2015, 4 pages.
 Non-final office action dated Dec. 31, 2015, for Design U.S. Appl. No. 29/538,746, filed Sep. 8, 2015, 17 pages.
 One Mile At A Time Blog, “Trunkster Zipperless Luggage—Thoughts?” Accessed on Nov. 25, 2015. Posted on Nov. 21, 2014, 13 pages. (<http://onemileatatime.boardingarea.com/2014/11/21/trunkster-zipperless-luggage-thoughts/>).
 U.S. Non-Final Office Action dated Jun. 22, 2016, for Design U.S. Appl. No. 29/538,746, filed Sep. 8, 2015, 6 pages.
 U.S. Non-final Office Action dated Feb. 7, 2017, for Design U.S. Appl. No. 29/525,533, filed Apr. 30, 2015, 6 pages.
 U.S. Non-Final Office Action dated Feb. 22, 2017, for U.S. Appl. No. 14/722,980, filed May 27, 2015, 6 pages.
 U.S. Non-Final Office Action dated Feb. 28, 2017, for U.S. Appl. No. 15/388,413, filed Dec. 22, 2016, 8 pages.
 U.S. Non-Final Office Action dated Aug. 4, 2017, for U.S. Appl. No. 15/389,044, filed Dec. 22, 2016, 6 pages.
 U.S. Notice of Allowance dated Oct. 3, 2016, for U.S. Appl. No. 29/539,269, filed Sep. 11, 2015, 7 pages.
 U.S. Notice of Allowance dated Apr. 13, 2017, for Design U.S. Appl. No. 29/525,533, filed Apr. 30, 2015, 7 pages.
 U.S. Restriction Requirement dated Oct. 18, 2016, for U.S. Appl. No. 14/722,980, filed May 27, 2015, 6 pages.
 U.S. Restriction Requirement dated Oct. 25, 2016, for Design U.S. Appl. No. 29/525,533, filed Apr. 30, 2015, four pages.
 Written Opinion dated Oct. 19, 2015, for PCT Application No. PCT/US2015/032667, filed on May 27, 2015, 7 pages.
 youtube.com, “Bluesmart—Prototype Demo #02”, Accessed on Nov. 25, 2015. Posted on Oct. 20, 2014, 2 pg. (<https://www.youtube.com/watch?v=z45Hwt91GXE>).

* cited by examiner

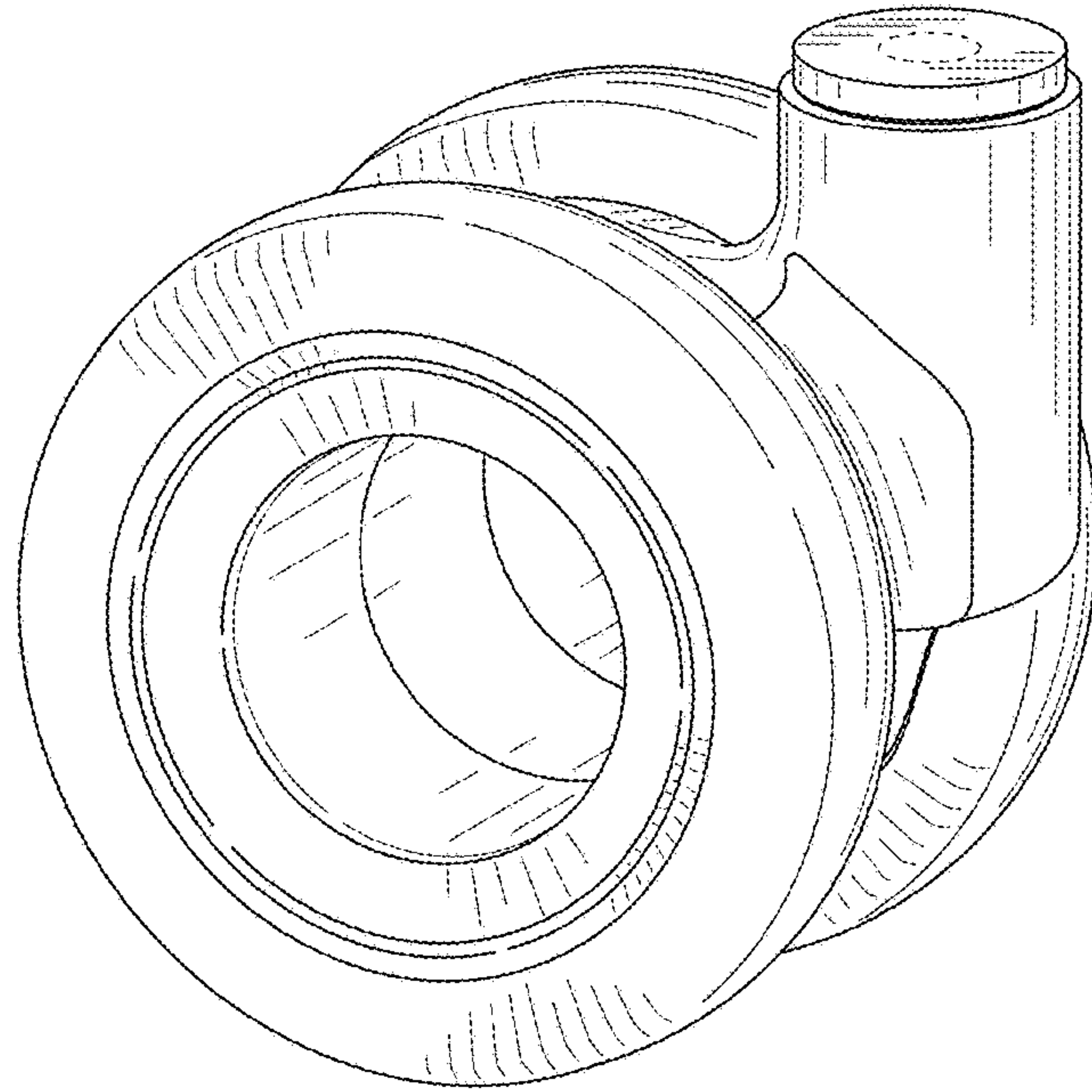

FIG. 1

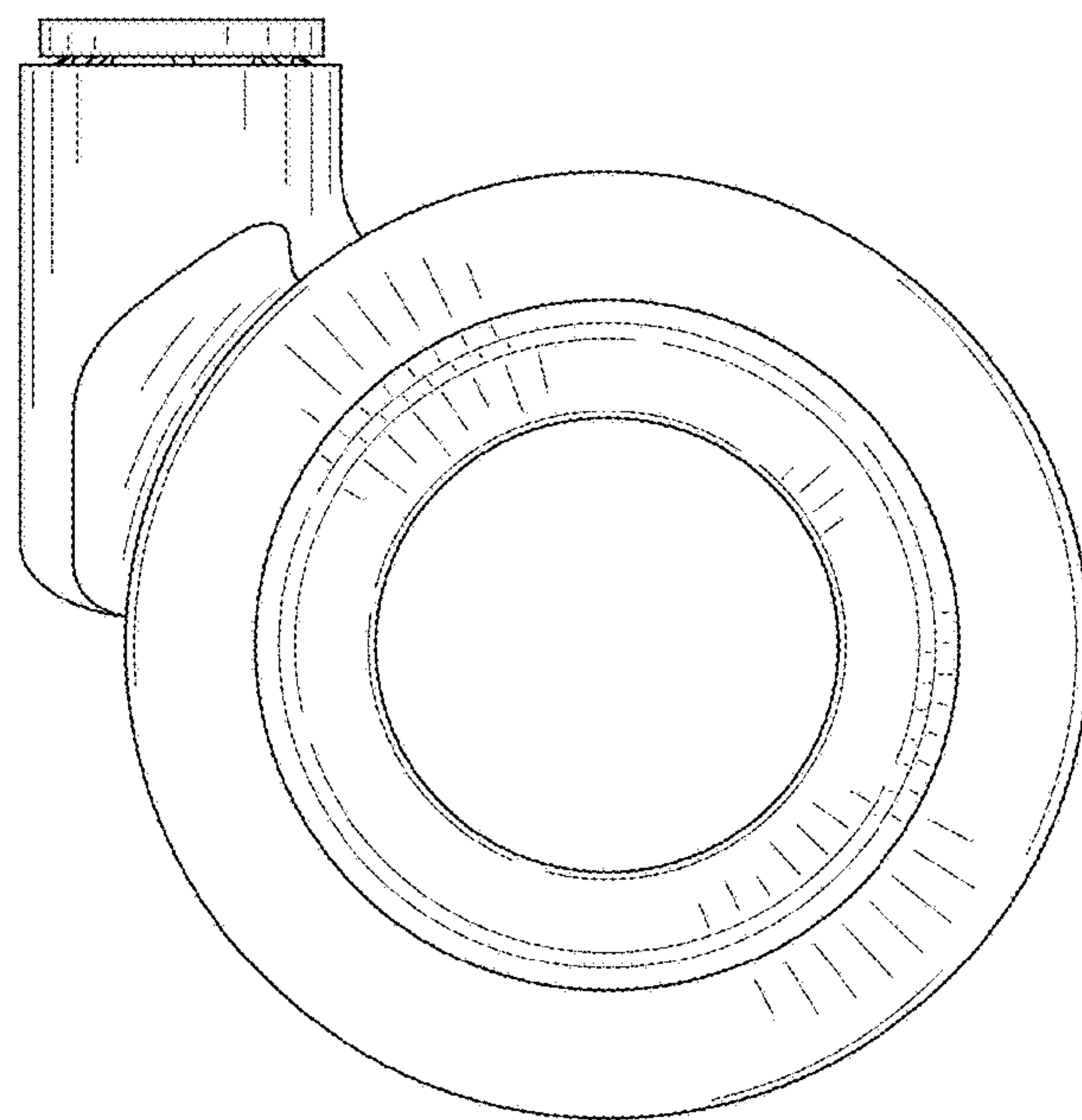

FIG. 2

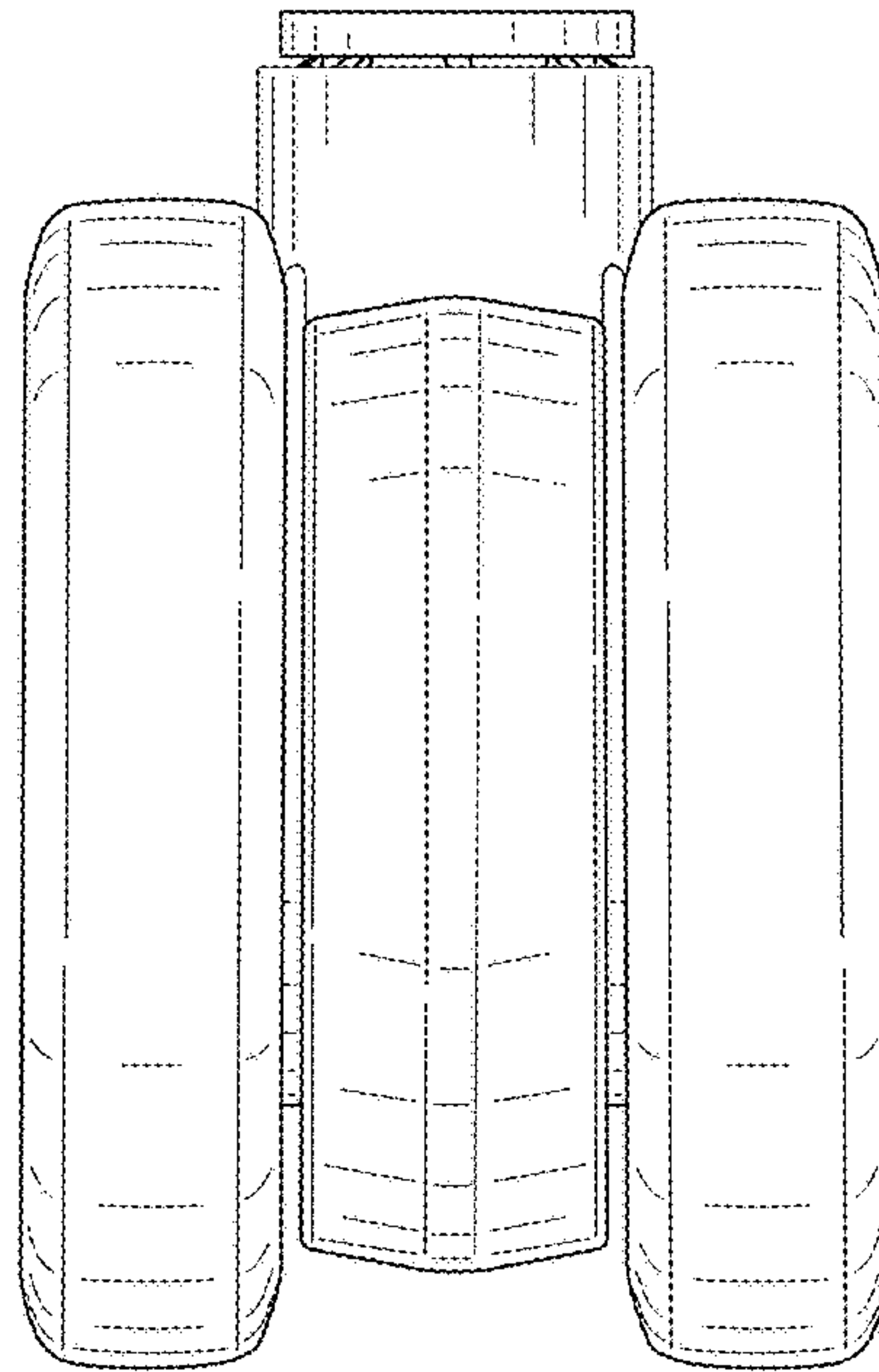

FIG. 3

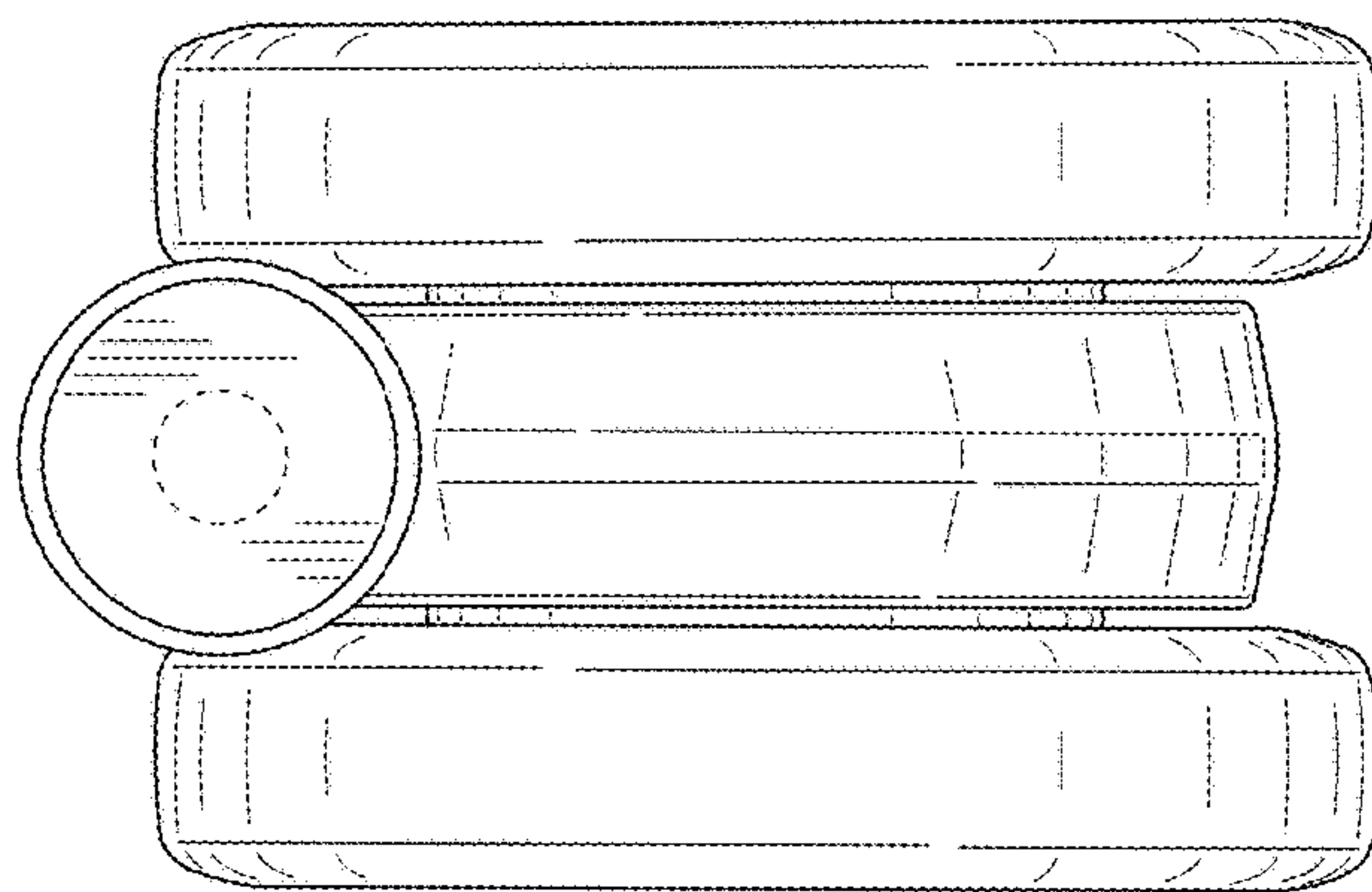

FIG. 4

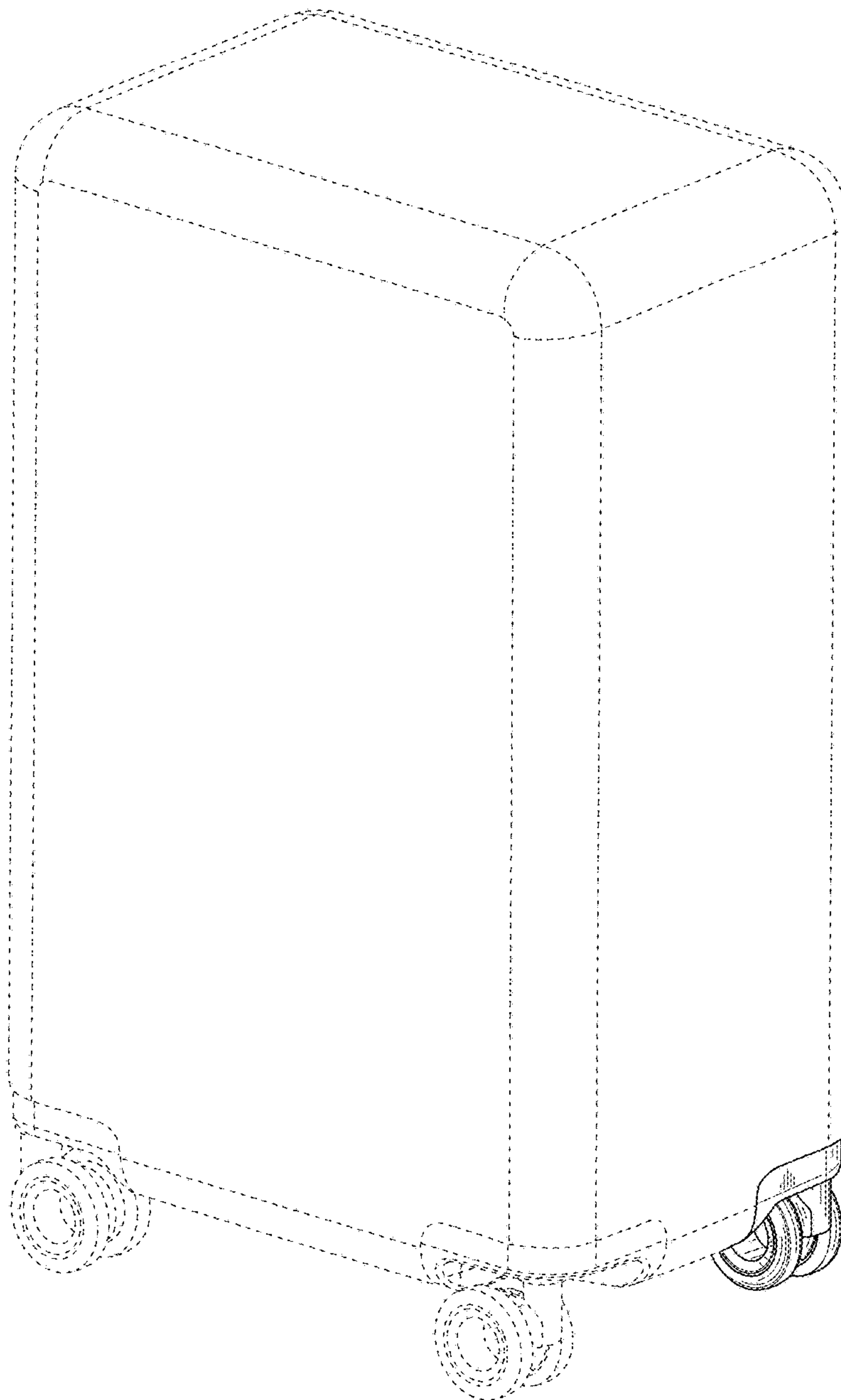

FIG. 5

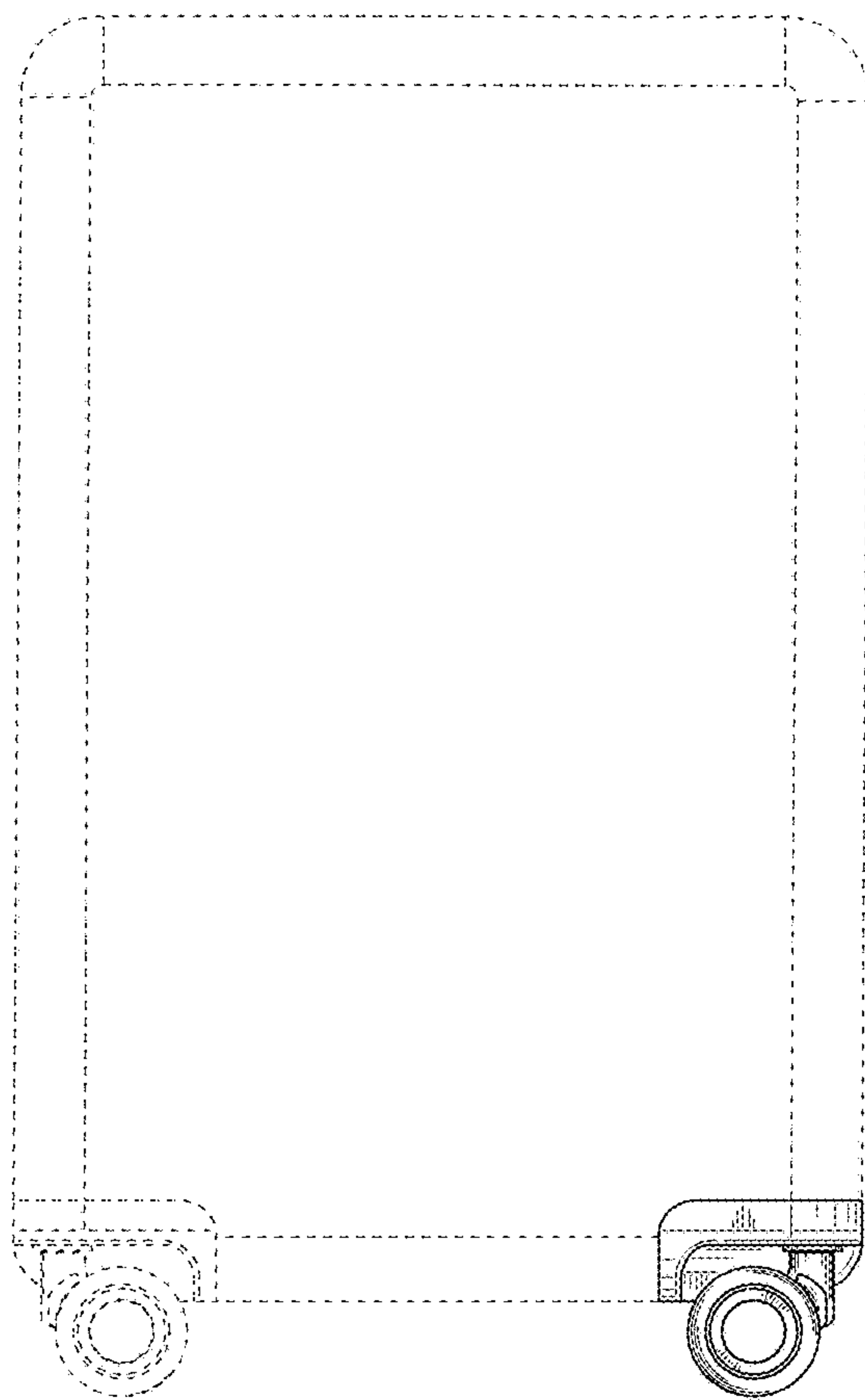

FIG. 6

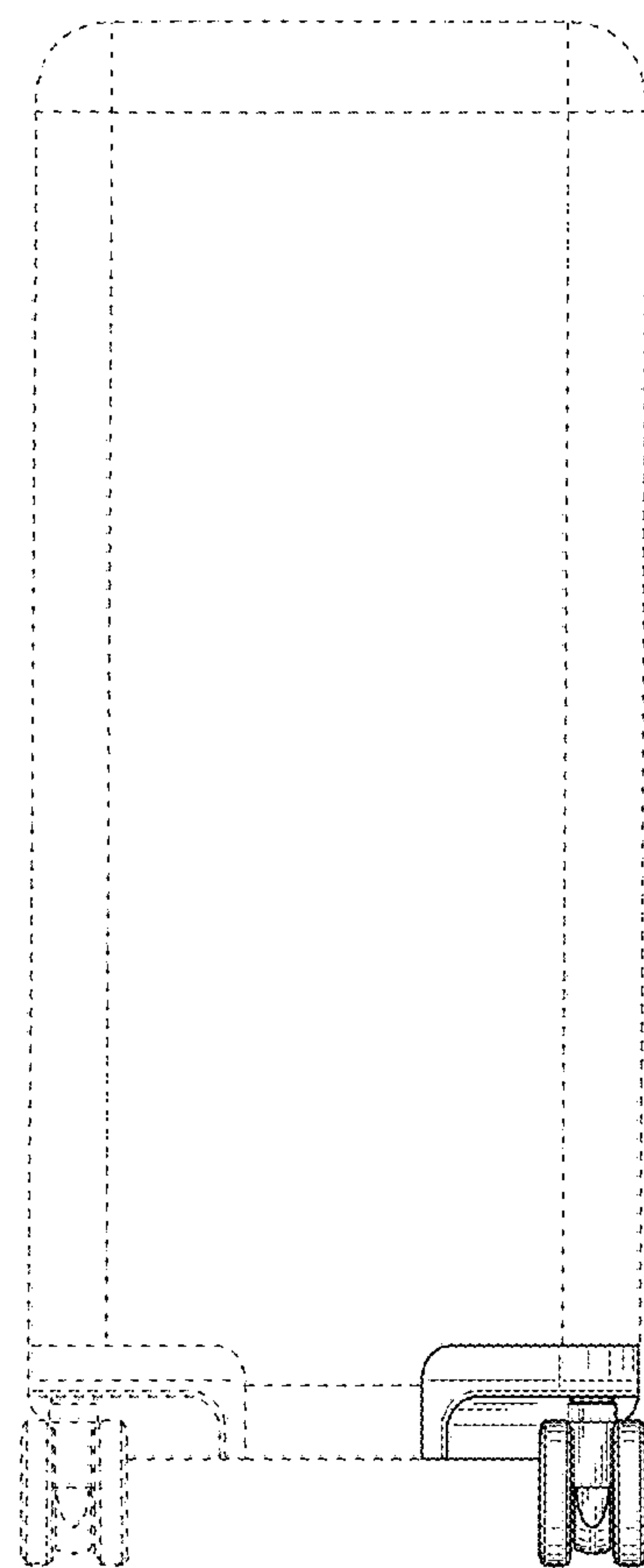

FIG. 7

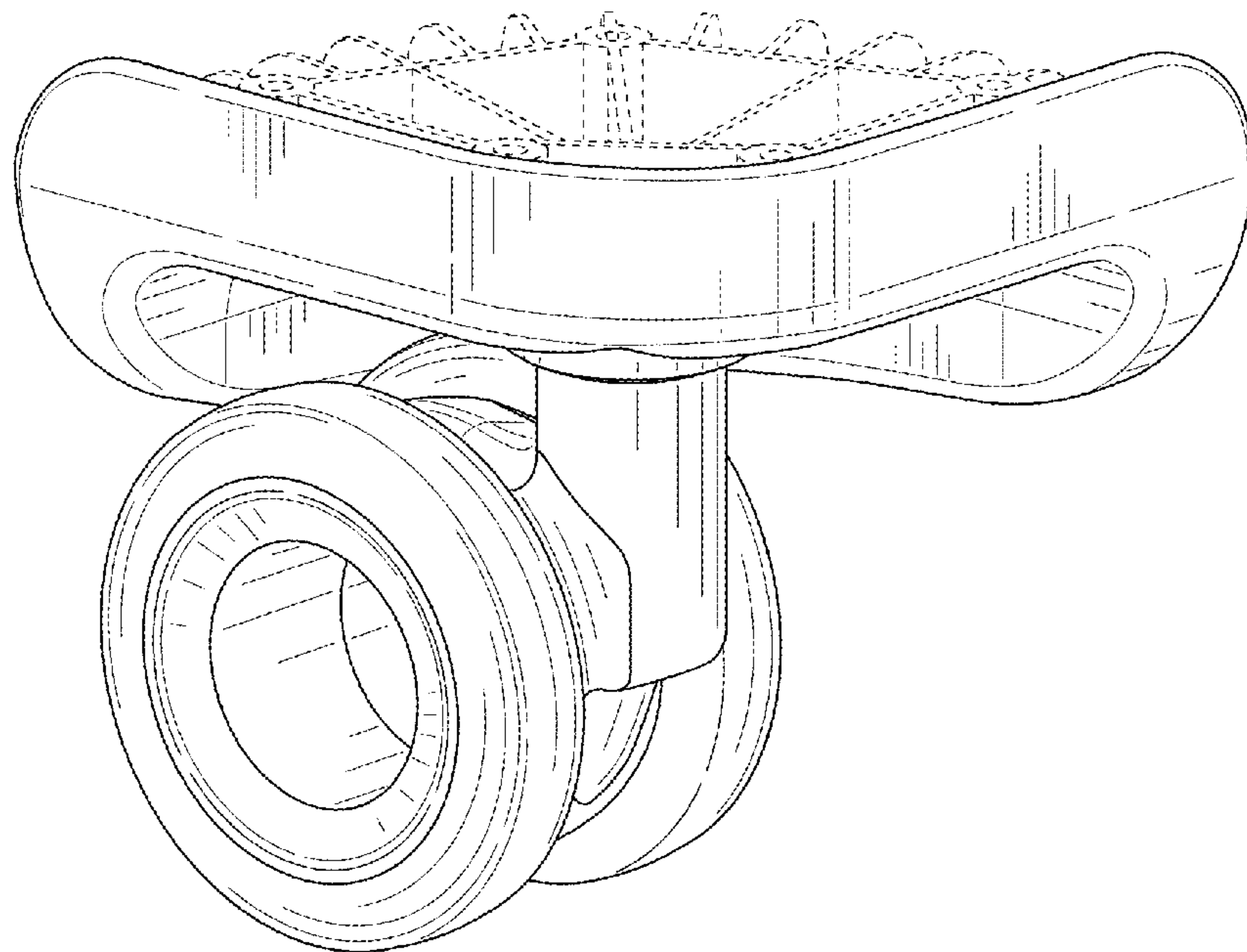

FIG. 8