



US00D855983S

(12) **United States Design Patent**  
**Pierre-Louis et al.**

(10) **Patent No.:** **US D855,983 S**  
(45) **Date of Patent:** **\*\* Aug. 13, 2019**

(54) **MULTI-USE BODY WALLET**

*Primary Examiner* — Holly H Baynham

(71) Applicants: **Claude Emmanuel Pierre-Louis**,  
Brooklyn, NY (US); **Elizabeth B  
Pierre-Louis**, Brooklyn, NY (US)

(57) **CLAIM**

We claim the ornamental design for a multi-use body wallet,  
as shown and described.

(72) Inventors: **Claude Emmanuel Pierre-Louis**,  
Brooklyn, NY (US); **Elizabeth B  
Pierre-Louis**, Brooklyn, NY (US)

**DESCRIPTION**

(\*\*) Term: **15 Years**

FIG. 1 is a left, perspective view of the multi-use body  
wallet showing our new design;  
FIG. 2 is an enlarged right side view with the strap attach-  
ments removed and the card holder flap raised;  
FIG. 3 is a front view thereof;  
FIG. 4 is a left side view thereof;  
FIG. 5 is a reduced scale front view of the second embodi-  
ment of the design shown in FIG. 1  
FIG. 6 is an enlarged, right side view with the strap  
attachments removed;  
FIG. 7 is a front view of the card holder insert, which is  
detached for clarity of illustration and is the same design for  
the first embodiment of the claimed design;  
FIG. 8. is a back view of the card holder insert;  
FIG. 9 is a left side view with the card holder flap raised;  
FIG. 10 is a left side view thereof; and,  
FIG. 11 is a front view thereof.

(21) Appl. No.: **29/620,686**

(22) Filed: **Apr. 26, 2017**

(51) **LOC (12) Cl.** ..... **03-01**

(52) **U.S. Cl.**  
USPC ..... **D3/249**

(58) **Field of Classification Search**  
USPC ..... D3/232–234, 238–243, 245–246, 248  
CPC ..... A45C 1/024; A45C 3/06  
See application file for complete search history.

The broken lines showing stitching are for the purposes of  
illustrating environment and form no part of the claimed  
design.

(56) **References Cited**

**U.S. PATENT DOCUMENTS**

|            |   |         |            |       |        |
|------------|---|---------|------------|-------|--------|
| D629,194 S | * | 12/2010 | Mitchell   | ..... | D3/234 |
| D651,397 S | * | 1/2012  | Lett       | ..... | D3/234 |
| D685,183 S | * | 7/2013  | Greenfield | ..... | D3/234 |

\* cited by examiner

**1 Claim, 5 Drawing Sheets**

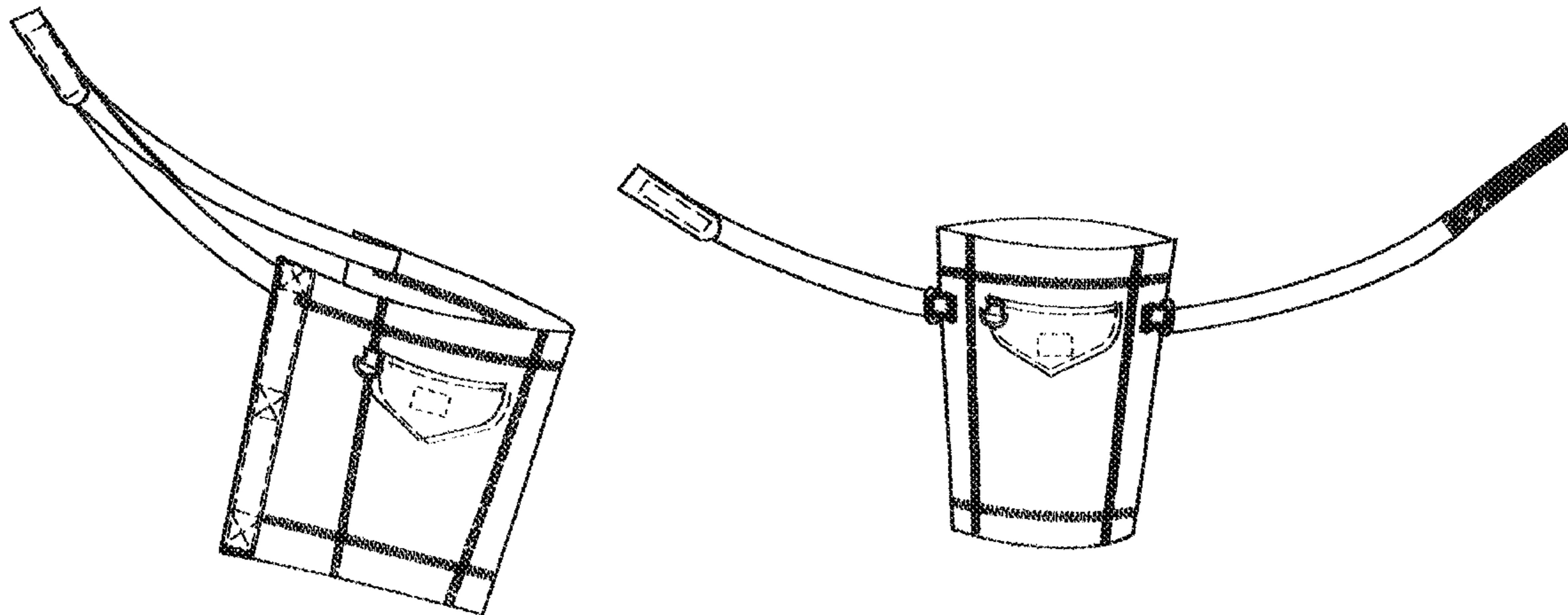

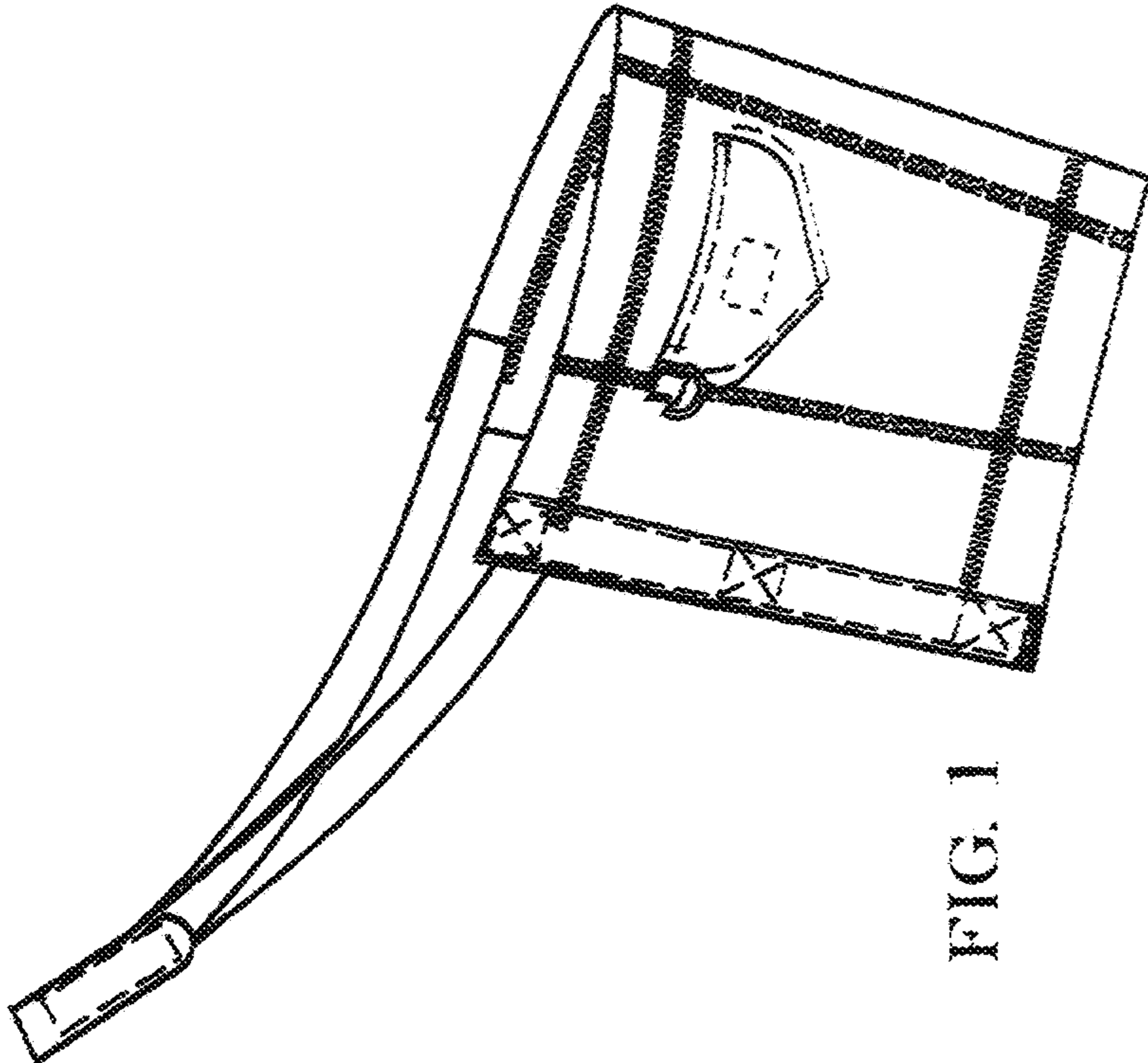

FIG. 1

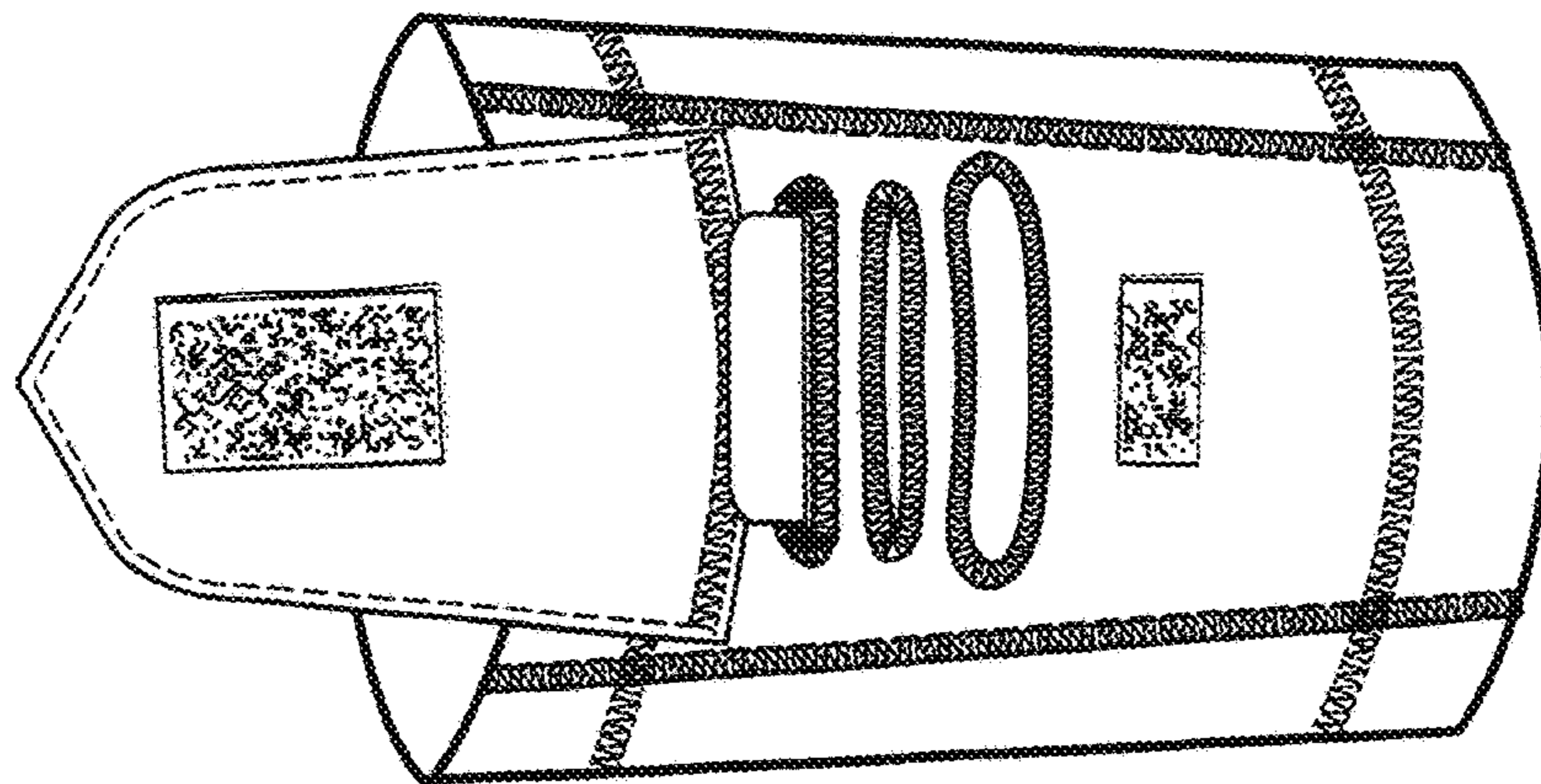

Fig. 2

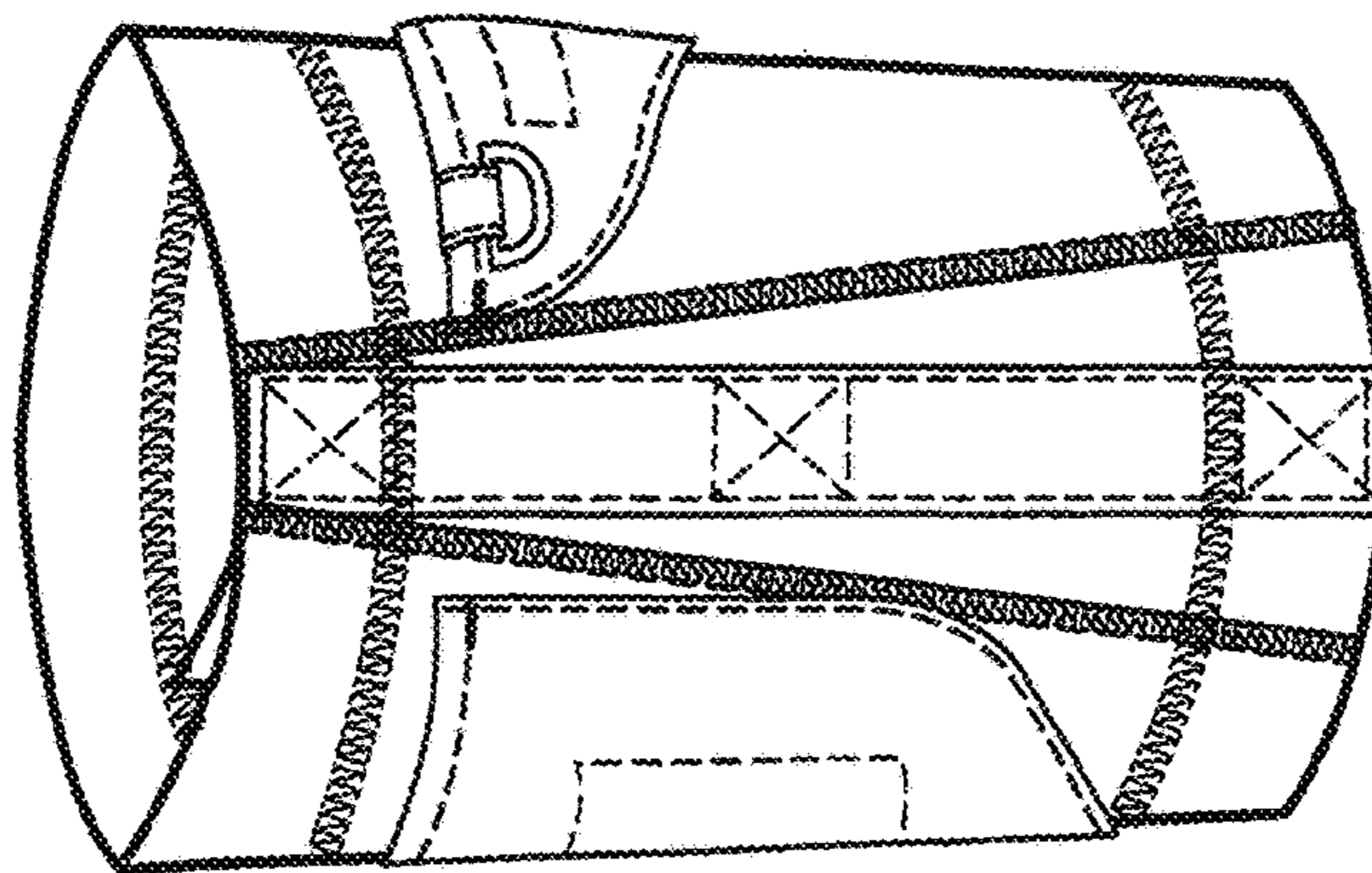

Fig. 3

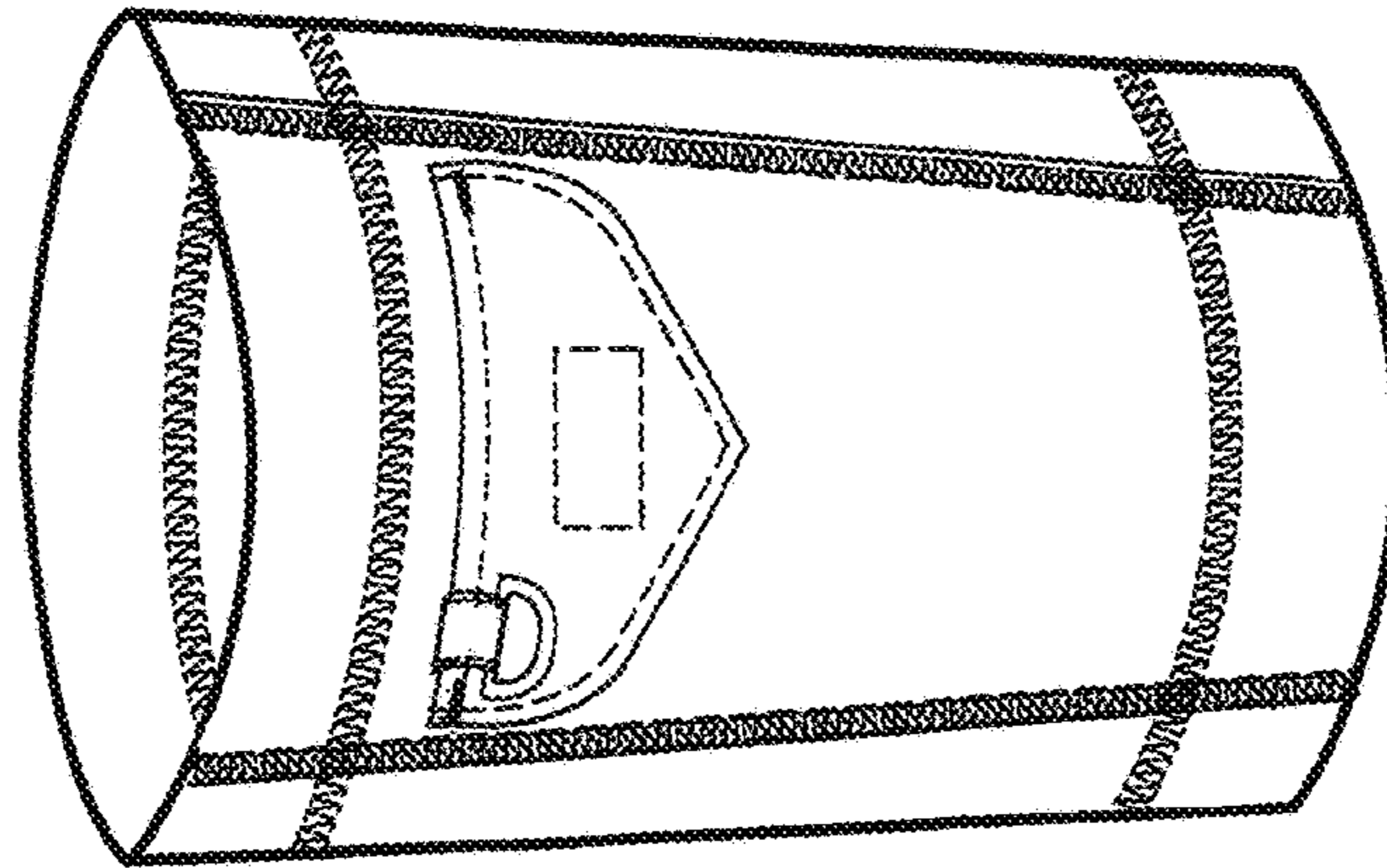

Fig. 4

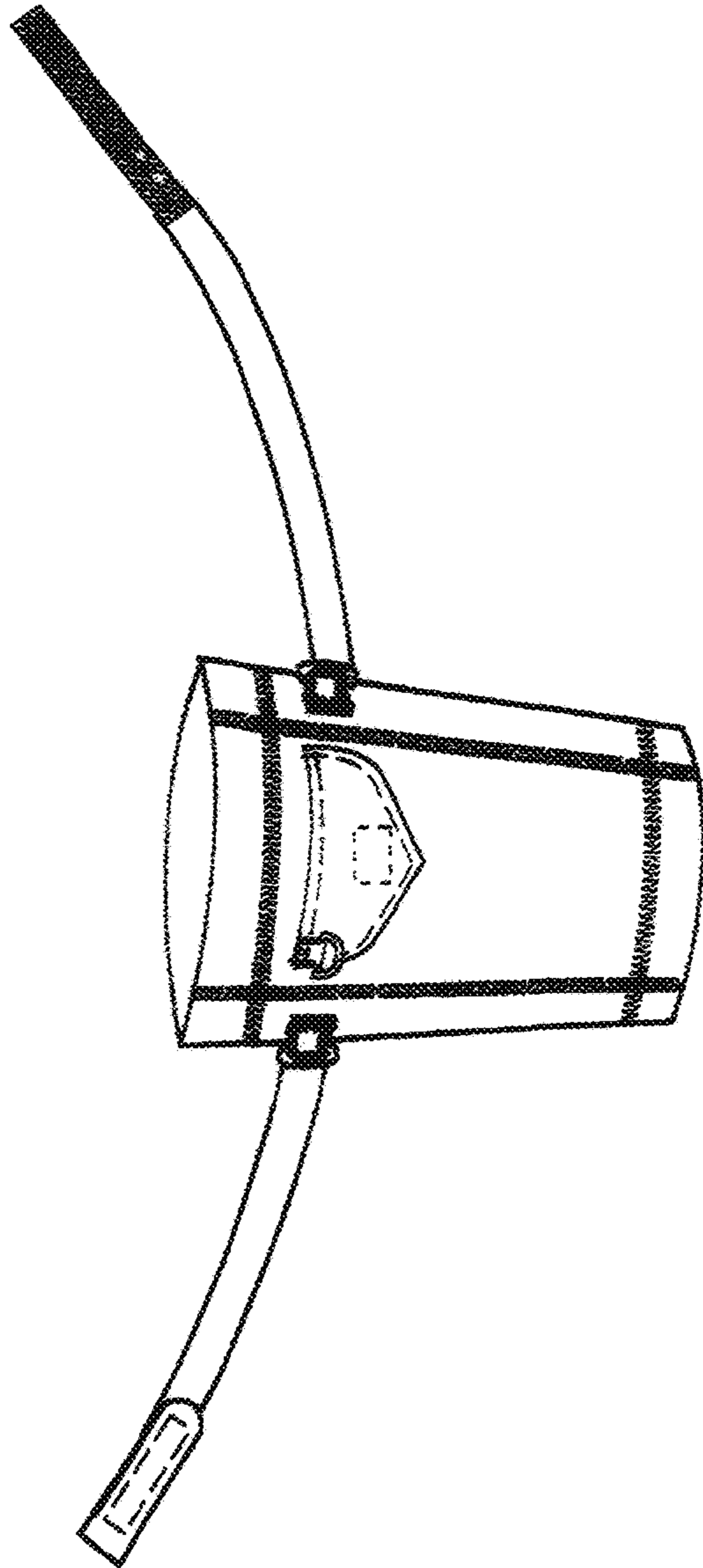
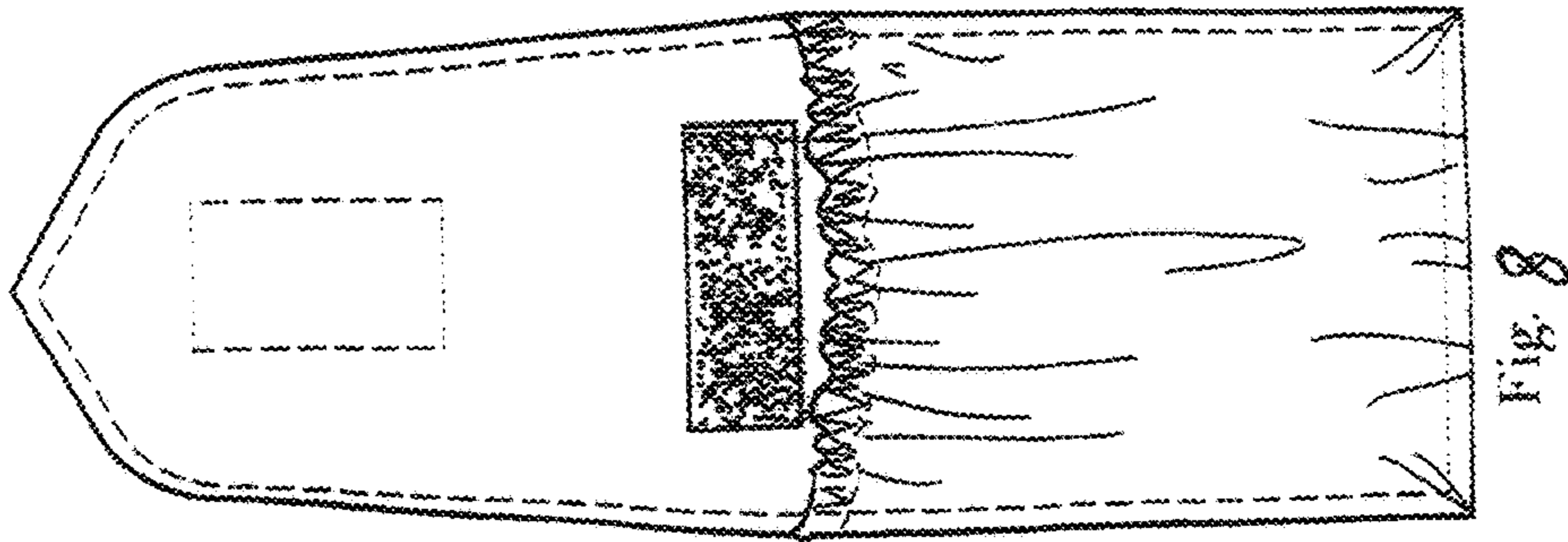
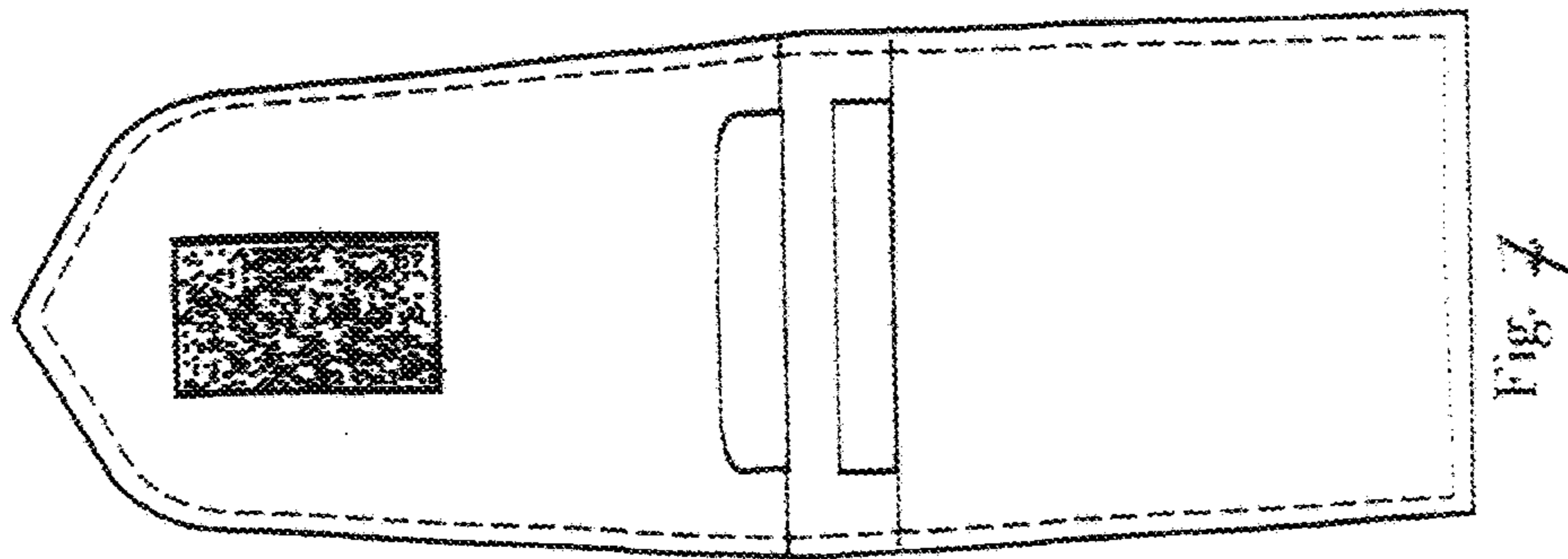
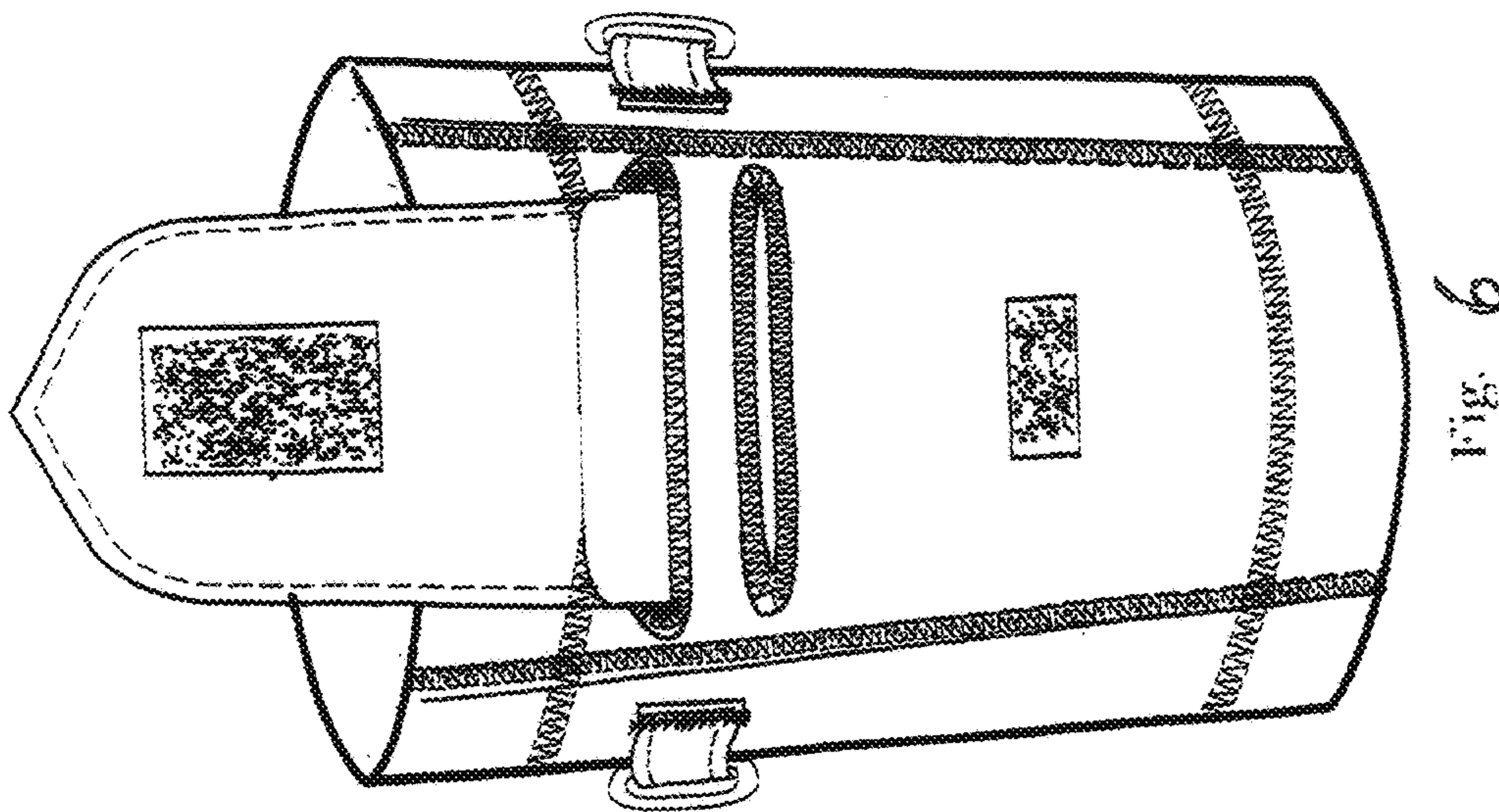

FIG. 5





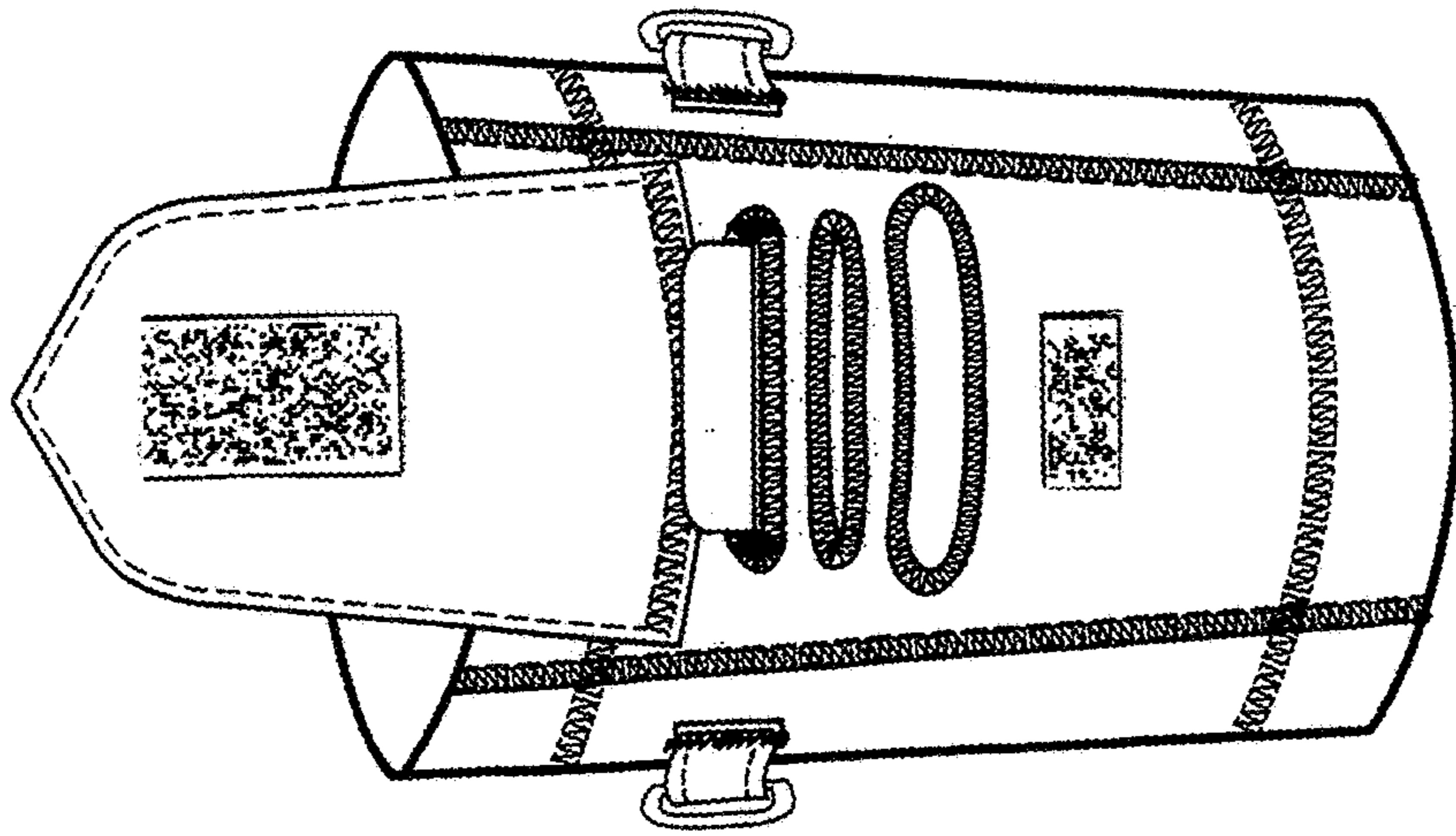

Fig. 9

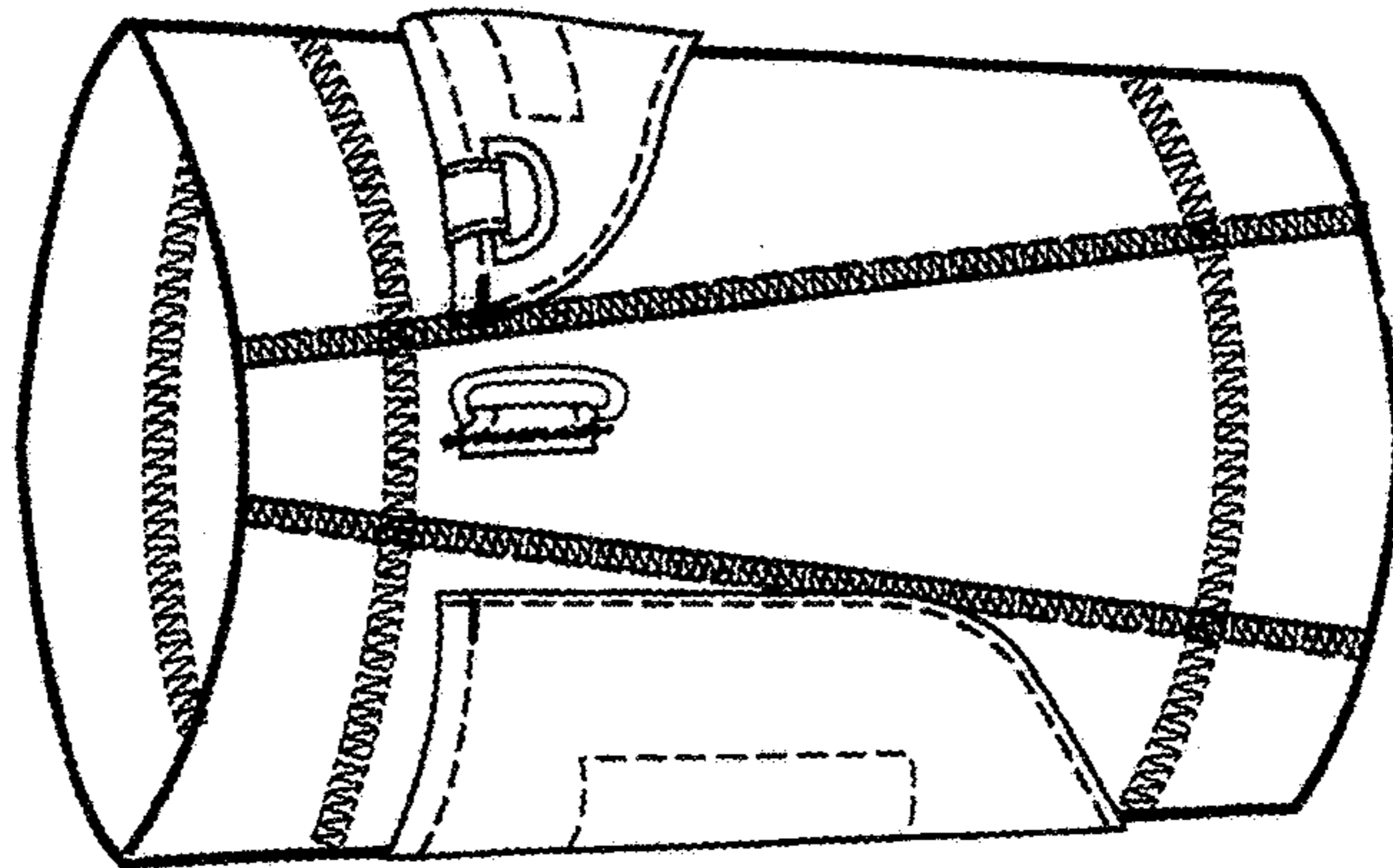

Fig. 10

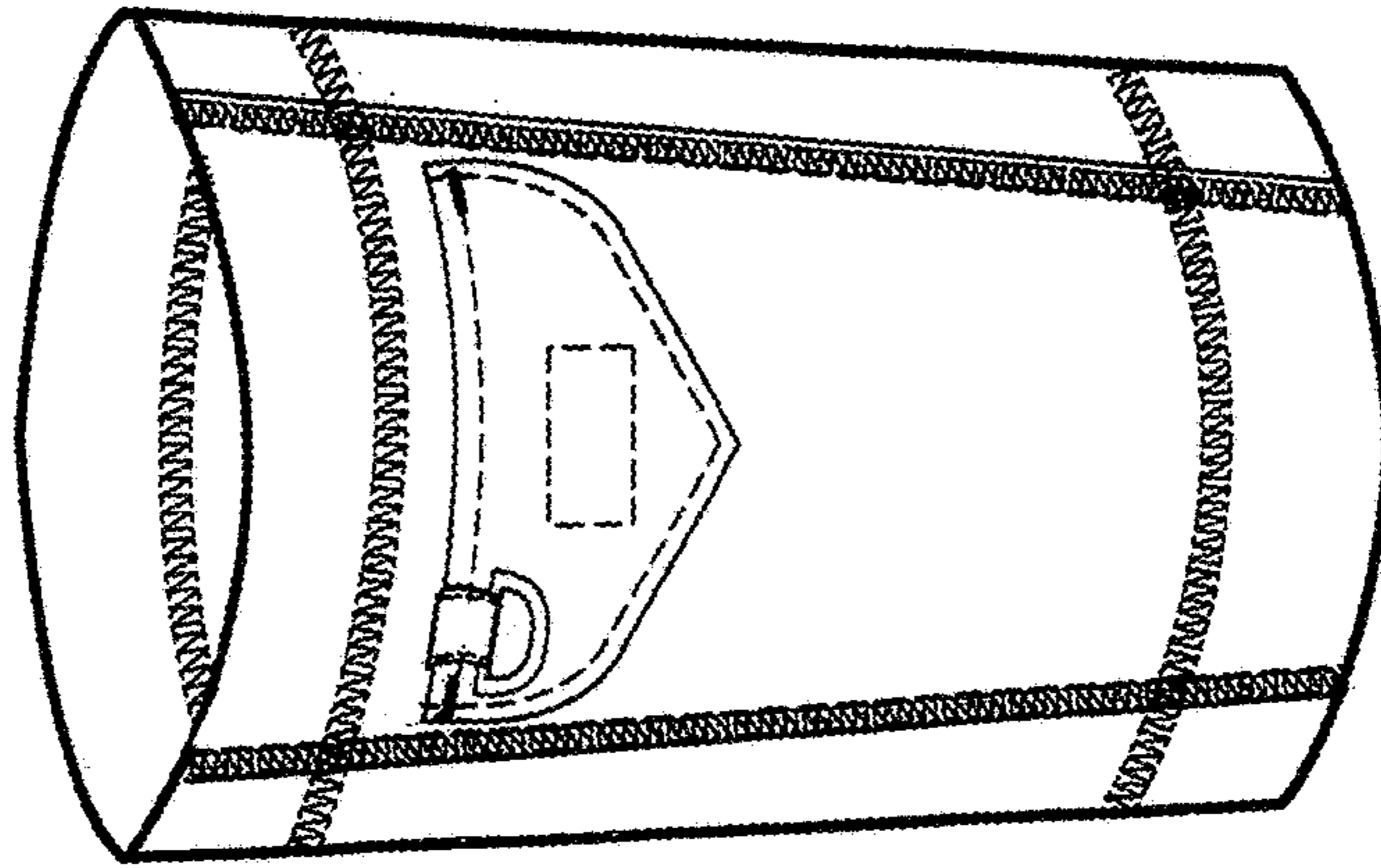

Fig. 11