



US00D855423S

(12) **United States Design Patent**  
**Walters**

(10) **Patent No.:** **US D855,423 S**

(45) **Date of Patent:** **\*\* Aug. 6, 2019**

(54) **DEVICE FOR GRIPPING AND PULLING WIRES**

(71) Applicant: **Paul A. Walters**, Fort Wayne, IN (US)

(72) Inventor: **Paul A. Walters**, Fort Wayne, IN (US)

(\*\*) Term: **15 Years**

(21) Appl. No.: **29/606,606**

(22) Filed: **Jun. 6, 2017**

(51) **LOC (12) Cl.** ..... **08-05**

(52) **U.S. Cl.**  
USPC ..... **D8/14**

(58) **Field of Classification Search**  
USPC ..... D8/14, 51, 107; D24/133  
CPC ..... H02G 1/08; H02G 1/081; H02G 1/083;  
H02G 1/085  
See application file for complete search history.

(56) **References Cited**

**U.S. PATENT DOCUMENTS**

- 4,819,911 A \* 4/1989 Cielker ..... H02G 1/085  
254/134.3 FT
- 5,423,517 A \* 6/1995 Rausch ..... H02G 1/085  
254/134.3 FT
- D420,885 S \* 2/2000 Lin ..... D8/107
- D448,633 S \* 10/2001 Langlois ..... D8/107

- D493,077 S \* 7/2004 Lamon ..... D8/14
- 7,152,846 B1 \* 12/2006 Jue ..... H02G 1/085  
254/134.3 FT

- D557,584 S \* 12/2007 Gao ..... D8/107
- D767,352 S \* 9/2016 Tarbell ..... D8/14
- 2006/0006370 A1 \* 1/2006 Khristo ..... H02G 1/085  
254/243

\* cited by examiner

*Primary Examiner* — Philip S Hyder

(74) *Attorney, Agent, or Firm* — David C. Purdue

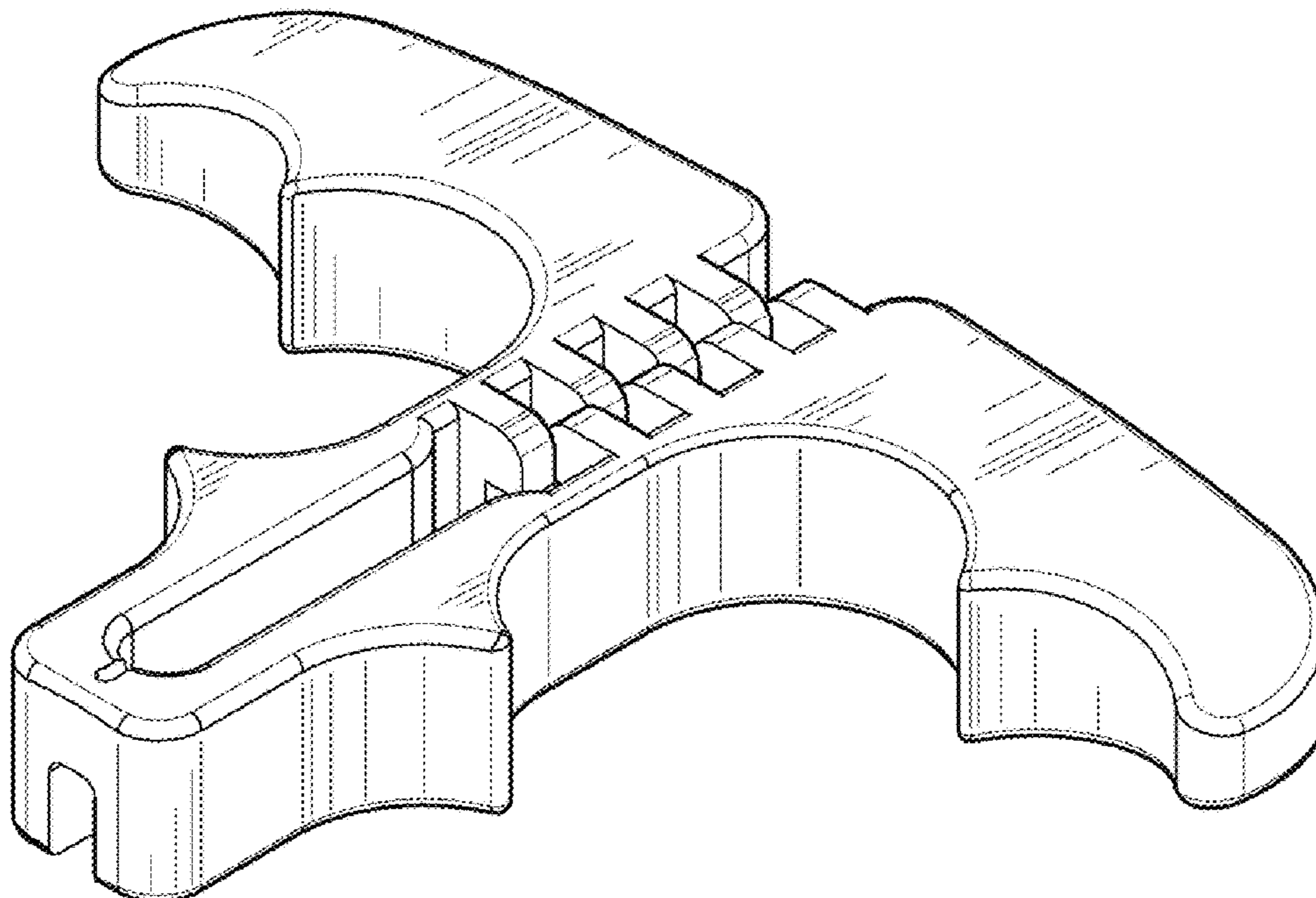
(57) **CLAIM**

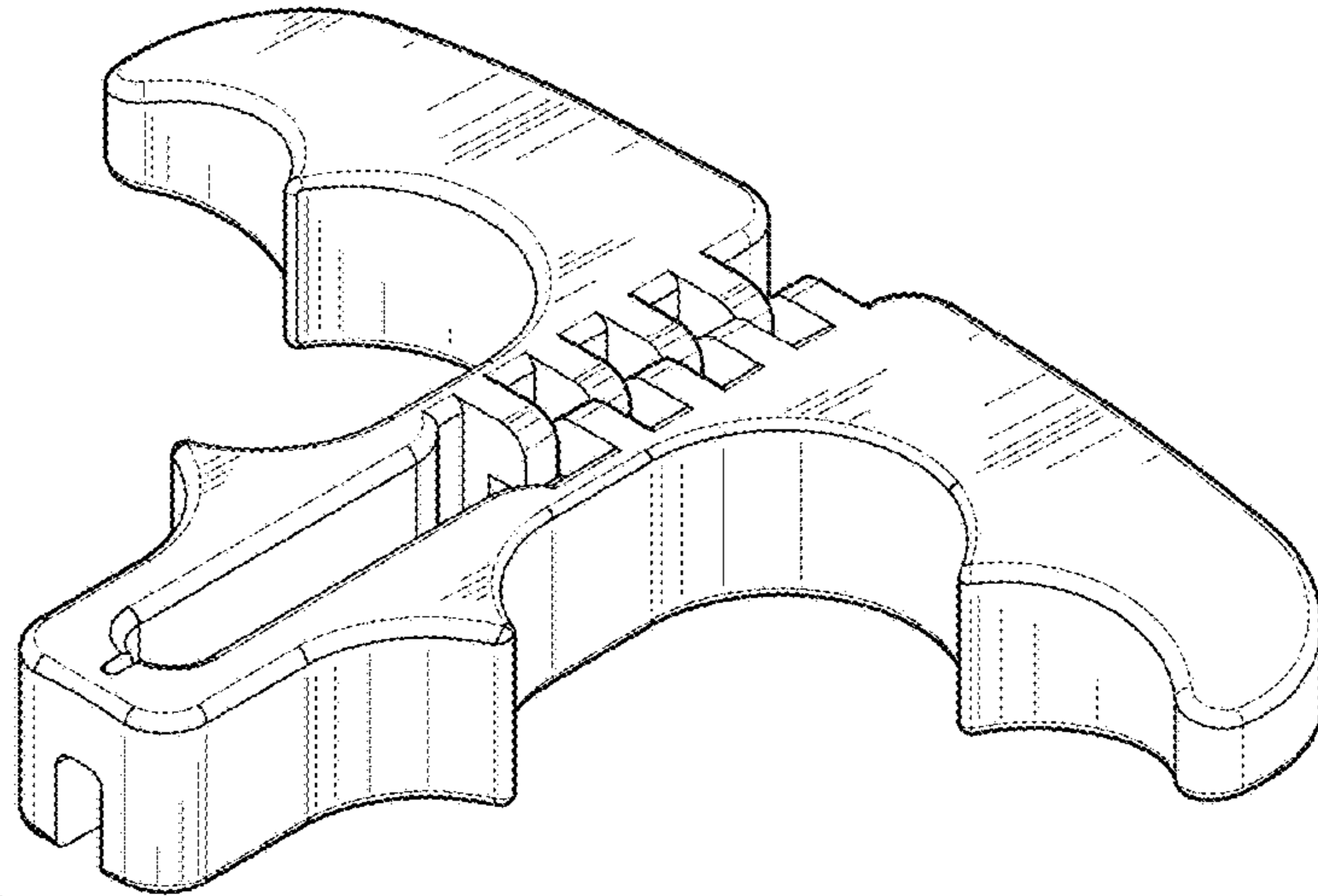
The ornamental design for a device for gripping and pulling wires, as shown and described.

**DESCRIPTION**

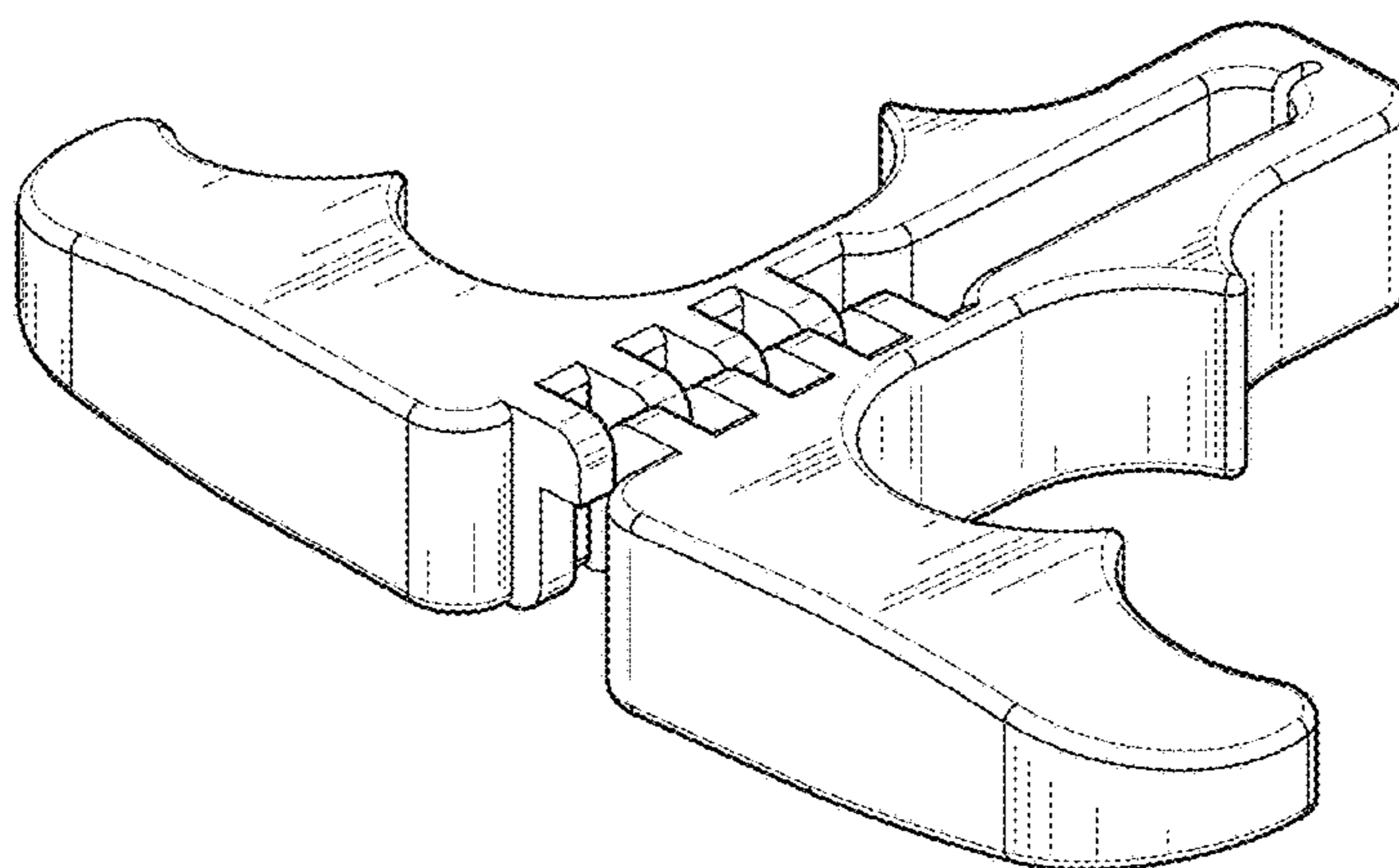
FIG. 1 is an upper right front perspective view of a device for gripping and pulling wires showing my design; FIG. 2 is a lower left rear view thereof; FIG. 3 is a top view thereof; FIG. 4 is a bottom view thereof; FIG. 5 is a front view thereof; FIG. 6 is a rear view thereof; and, FIG. 7 is a right side view thereof, the left side view being the mirror image of the right side view.

**1 Claim, 3 Drawing Sheets**

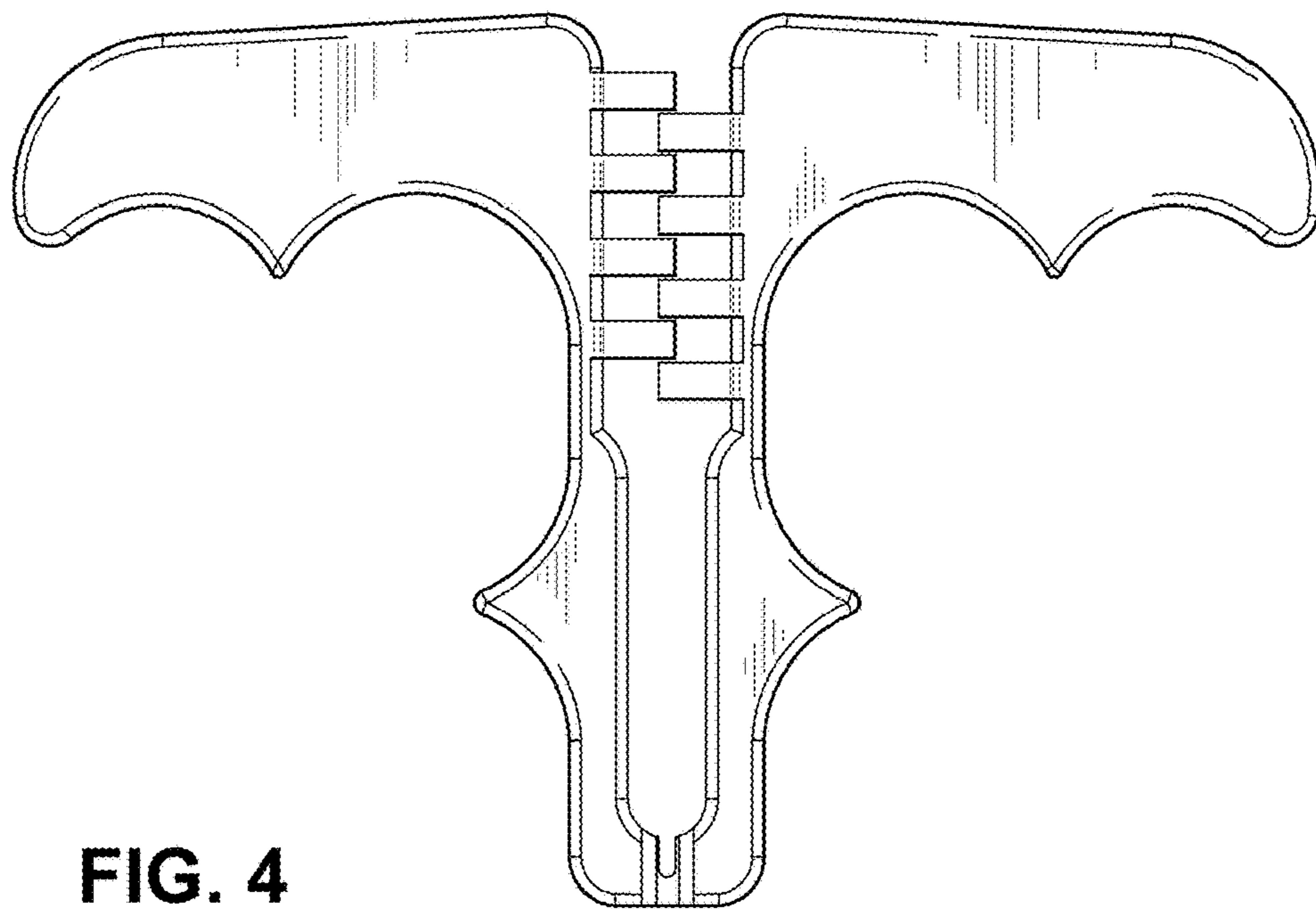
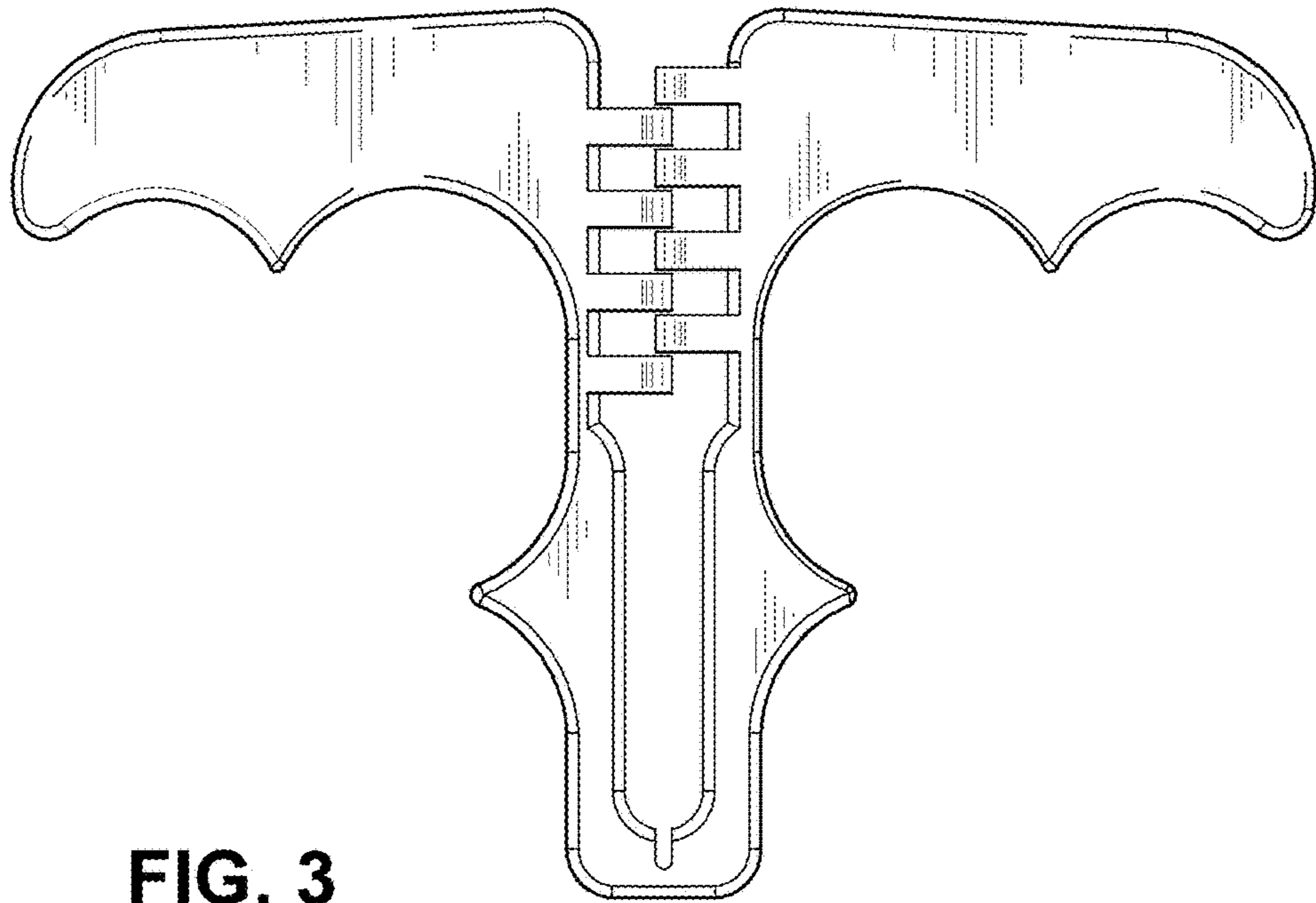


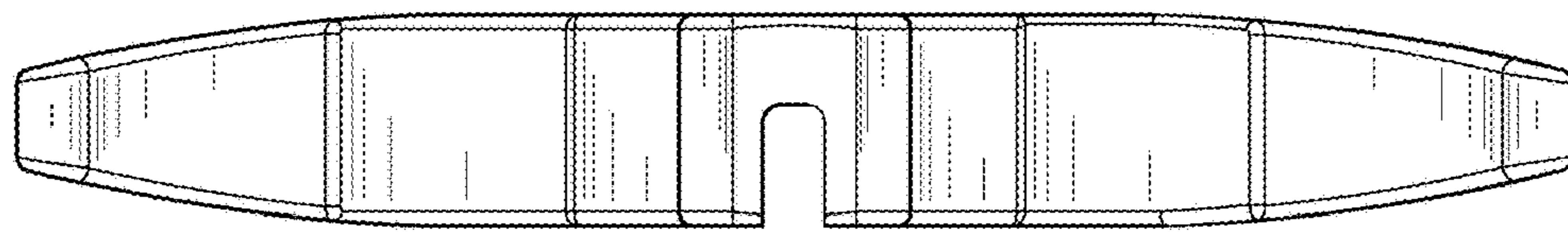


**FIG. 1**

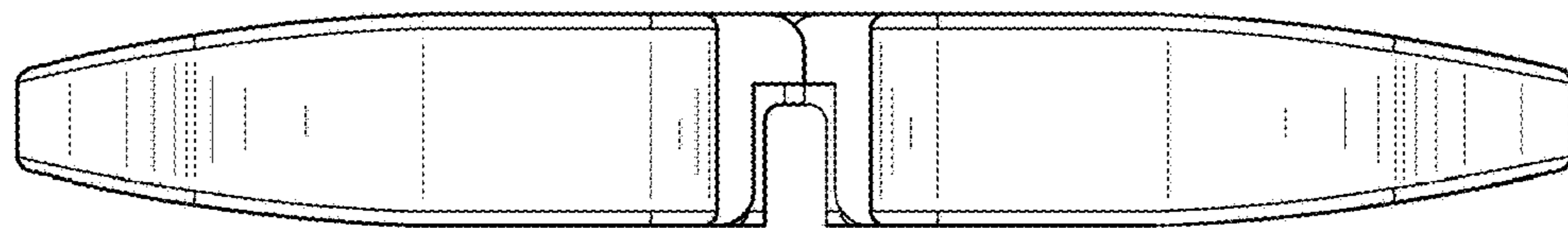


**FIG. 2**

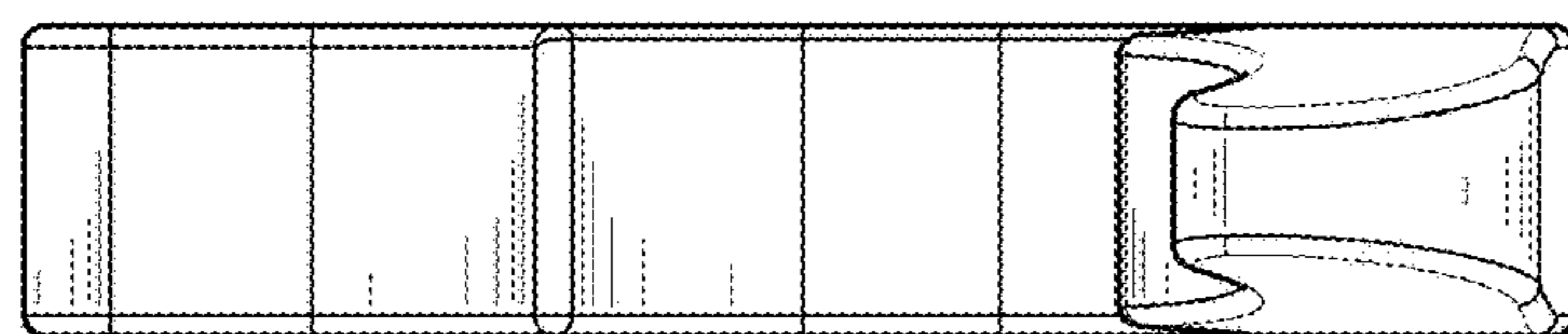




**FIG. 5**



**FIG. 6**



**FIG. 7**