

US00D854993S

(12) **United States Design Patent** (10) **Patent No.:** **US D854,993 S**
Von Holzhausen et al. (45) **Date of Patent:** **** Jul. 30, 2019**

(54) **CHARGE-PORT DOOR**
(71) Applicant: **Tesla, Inc.**, Palo Alto, CA (US)
(72) Inventors: **Franz Von Holzhausen**, Malibu, CA (US); **David Tadashi Imai**, Los Angeles, CA (US); **Randy Rodriguez**, Torrance, CA (US)
(73) Assignee: **Tesla, Inc.**, Palo Alto, CA (US)
(**) Term: **15 Years**
(21) Appl. No.: **29/619,064**
(22) Filed: **Sep. 26, 2017**
(51) **LOC (11) Cl.** **12-16**
(52) **U.S. Cl.**
USPC **D12/196**
(58) **Field of Classification Search**
USPC D12/181, 184, 186, 196; D26/28, 29, 30, D26/31, 32, 33, 34, 35, 36
CPC B60Q 9/13; B60Q 9/135; B60Q 9/1375; F21S 48/00; F21S 48/10; F21S 48/115; F21S 48/225; F21S 48/1233; F21S 48/1266; F21S 48/1388; F21S 48/2268; F21V 21/04
See application file for complete search history.

(56) **References Cited**
U.S. PATENT DOCUMENTS
D285,428 S * 9/1986 Cline D12/181
6,203,355 B1 * 3/2001 Neblett H01R 13/62933
439/372
D545,744 S * 7/2007 Turner D12/196
D609,149 S * 2/2010 Larson D12/181
D628,947 S * 12/2010 Yoshida D12/181
7,999,665 B2 * 8/2011 Chander B60Q 9/00
340/455
D644,584 S * 9/2011 Vardis D12/190

8,317,376 B2 * 11/2012 Hook B60Q 1/2661
362/459
D681,516 S * 5/2013 Jara D12/169
9,455,595 B2 * 9/2016 Jeon H02J 7/0044
D775,031 S * 12/2016 Frascella D12/184
D777,633 S * 1/2017 Schneider D12/196
9,656,561 B2 * 5/2017 Yoo B60L 11/1818
9,662,990 B2 * 5/2017 Jeong B60K 15/05
9,789,783 B2 * 10/2017 Grider B60L 11/1861

* cited by examiner
Primary Examiner — Susan Bennett Hattan
Assistant Examiner — Suzanne E Tisdell
(74) *Attorney, Agent, or Firm* — Haynes and Boone, LLP

(57) **CLAIM**
The ornamental design for a charge-port door, as shown and described.

DESCRIPTION
FIG. 1 is a perspective view of a charge-port door.
FIG. 2 is a front elevational view of the charge-port door of FIG. 1.
FIG. 3 is a back elevational view of the charge-port door of FIG. 1.
FIG. 4 is a side elevational view of the charge-port door of FIG. 1.
FIG. 5 is a side elevational view of the charge-port door of FIG. 1 from the opposite side from FIG. 4.
FIG. 6 is a top plan view of the charge-port door of FIG. 1.
FIG. 7 is a bottom plan view of the charge-port door of FIG. 1; and,
FIG. 8 is a perspective view of the charge-port door of FIG. 1 as part of a semi-truck cab.
The items shown with broken lines form no part of the claimed design.

1 Claim, 6 Drawing Sheets

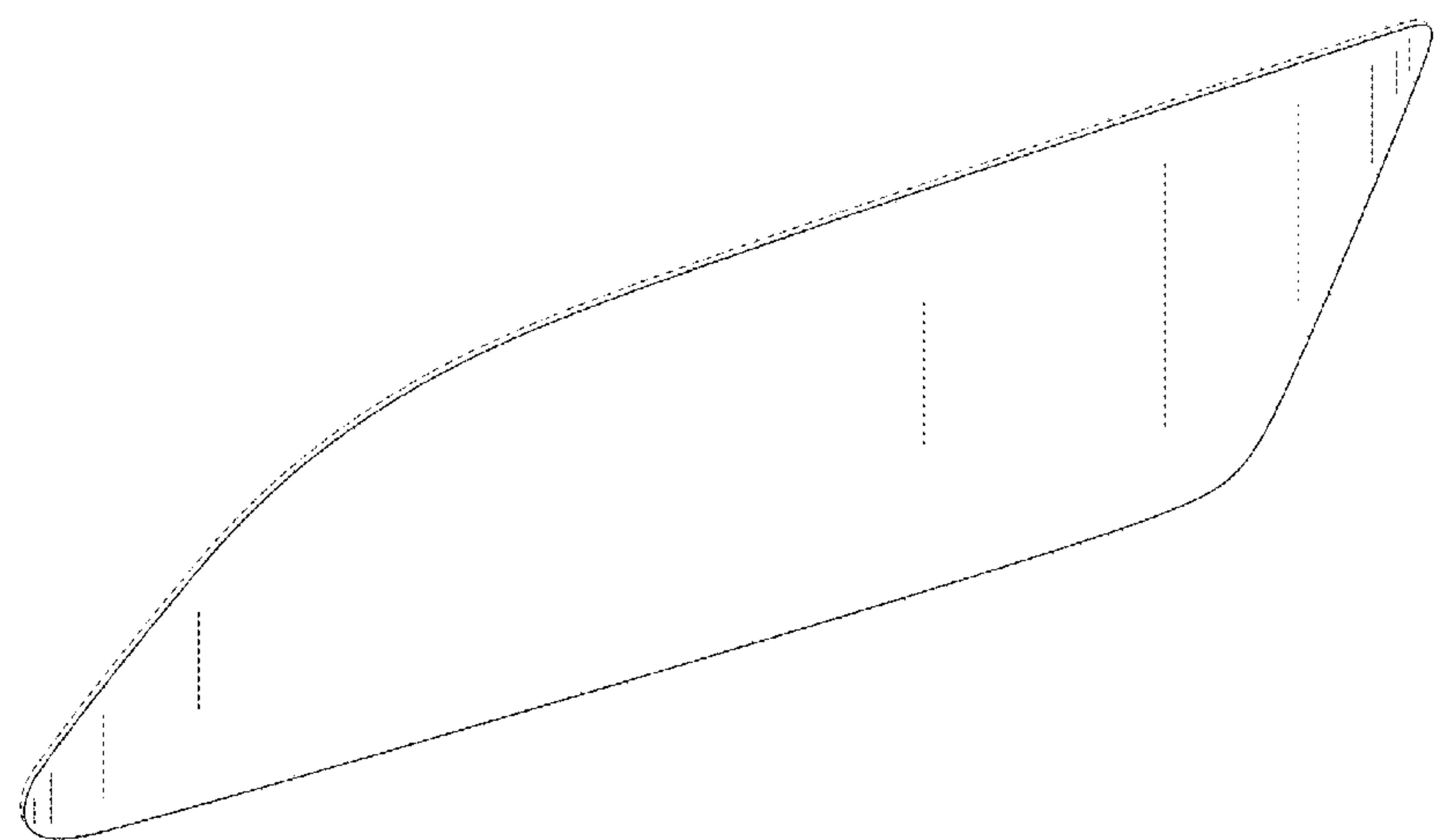

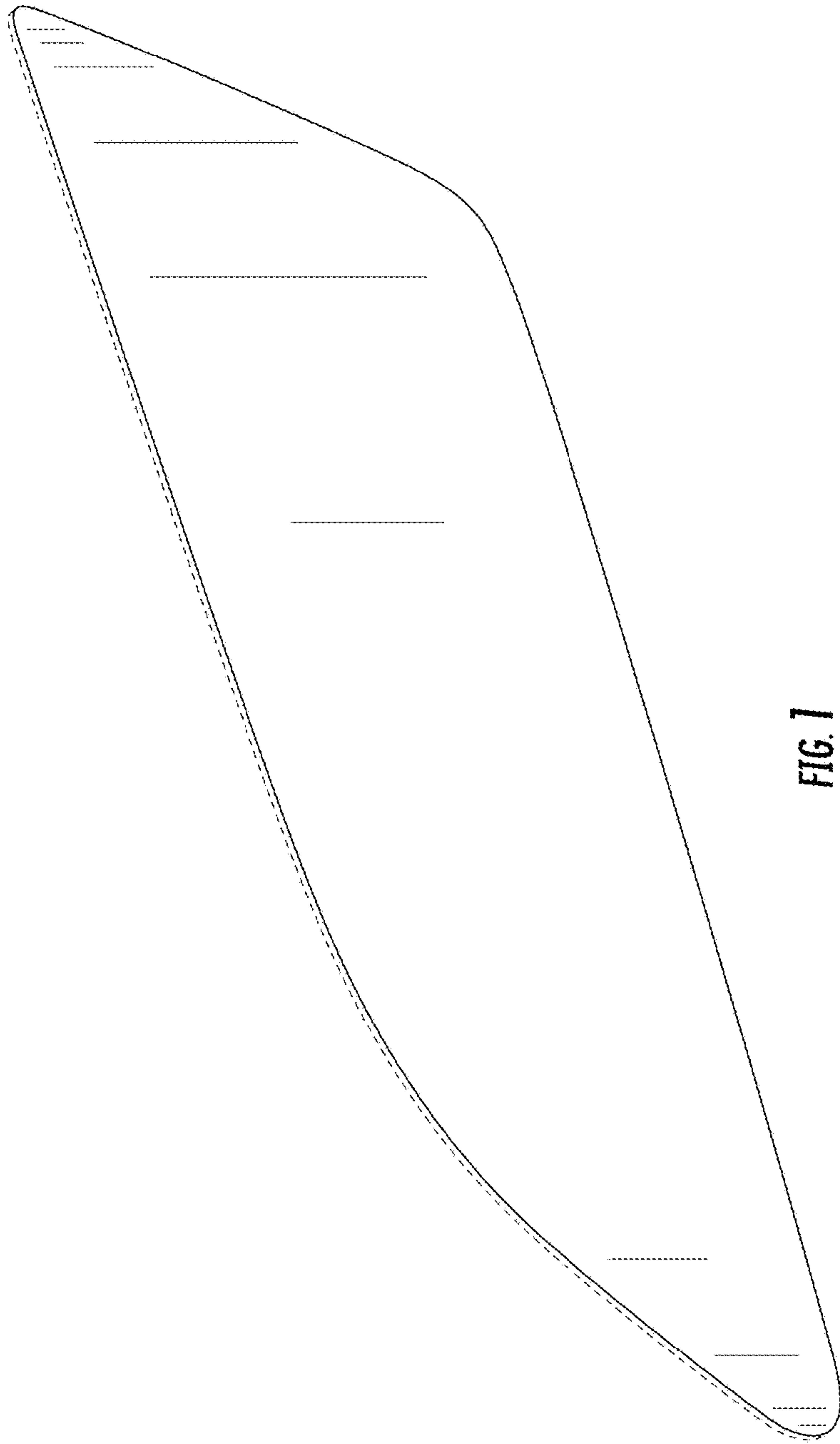

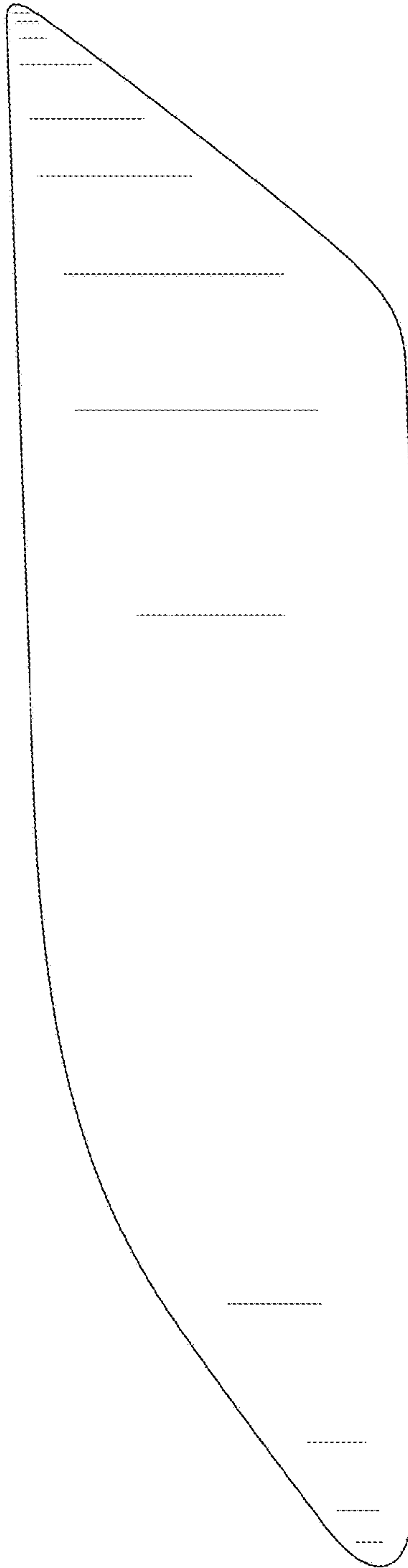

FIG. 2

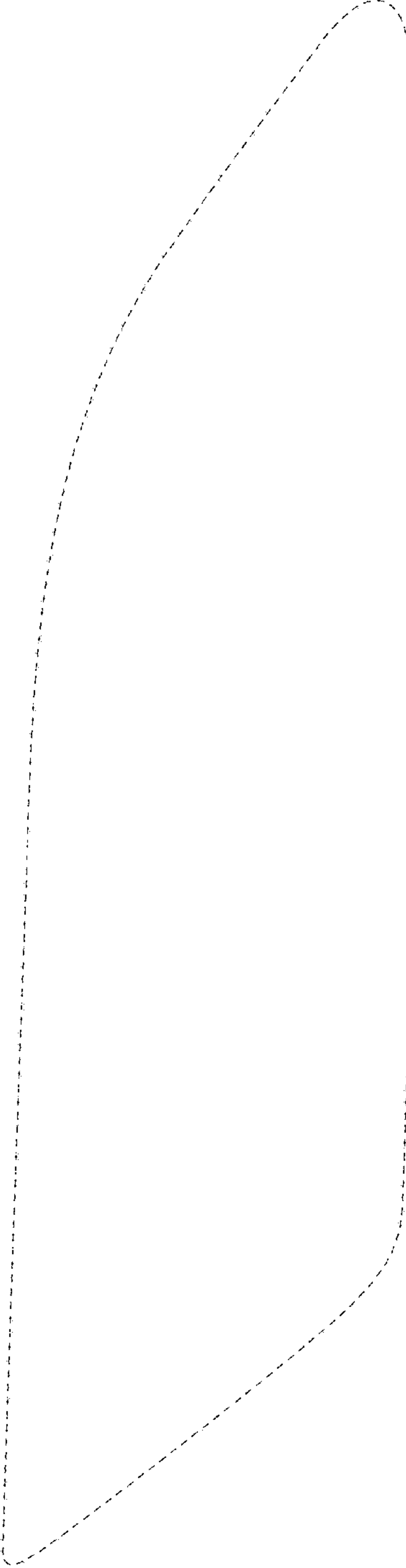

FIG. 3

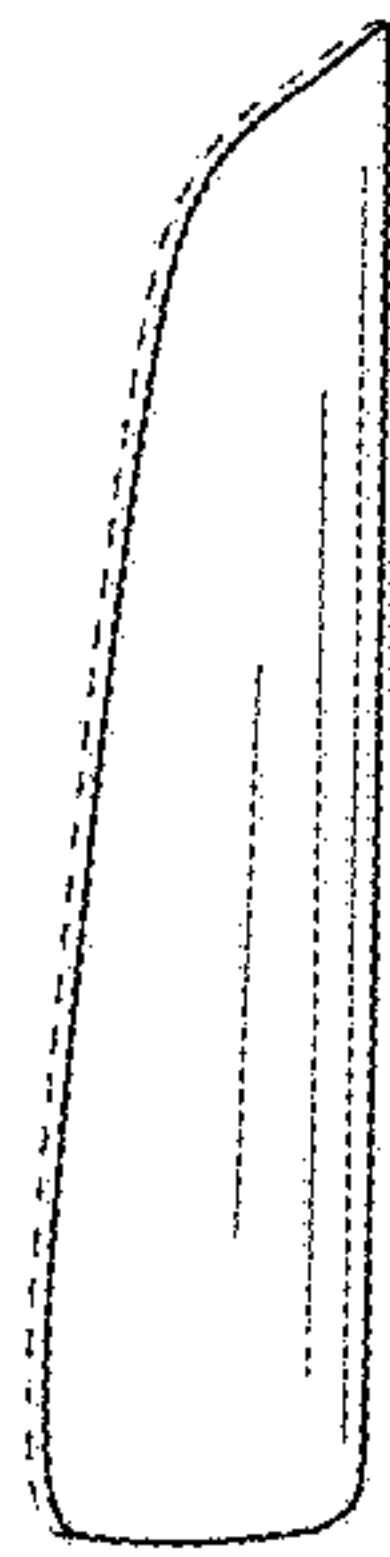

FIG. 4

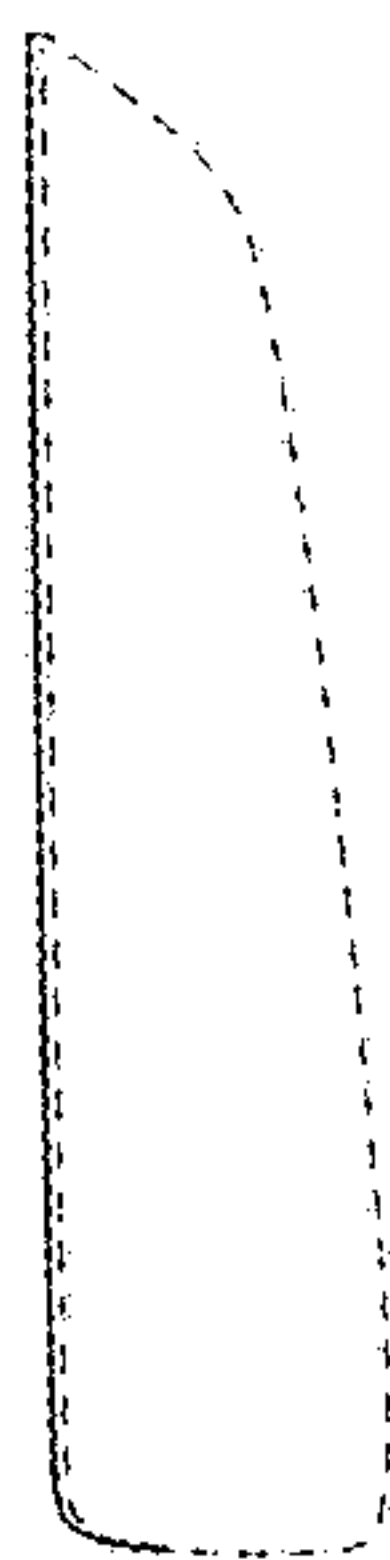

FIG. 5

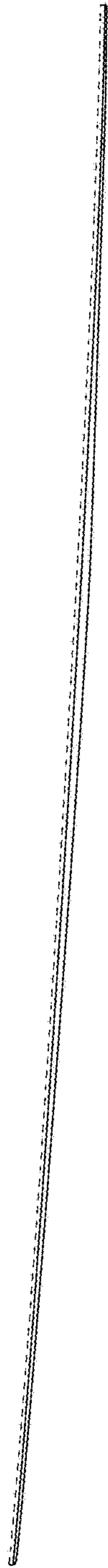

FIG. 6

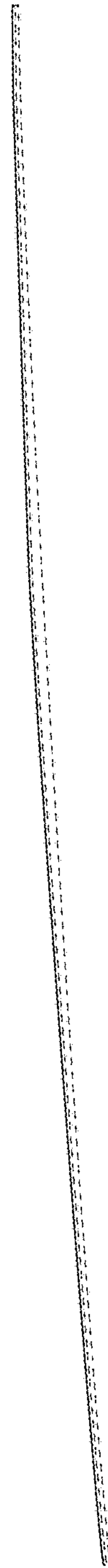

FIG. 7

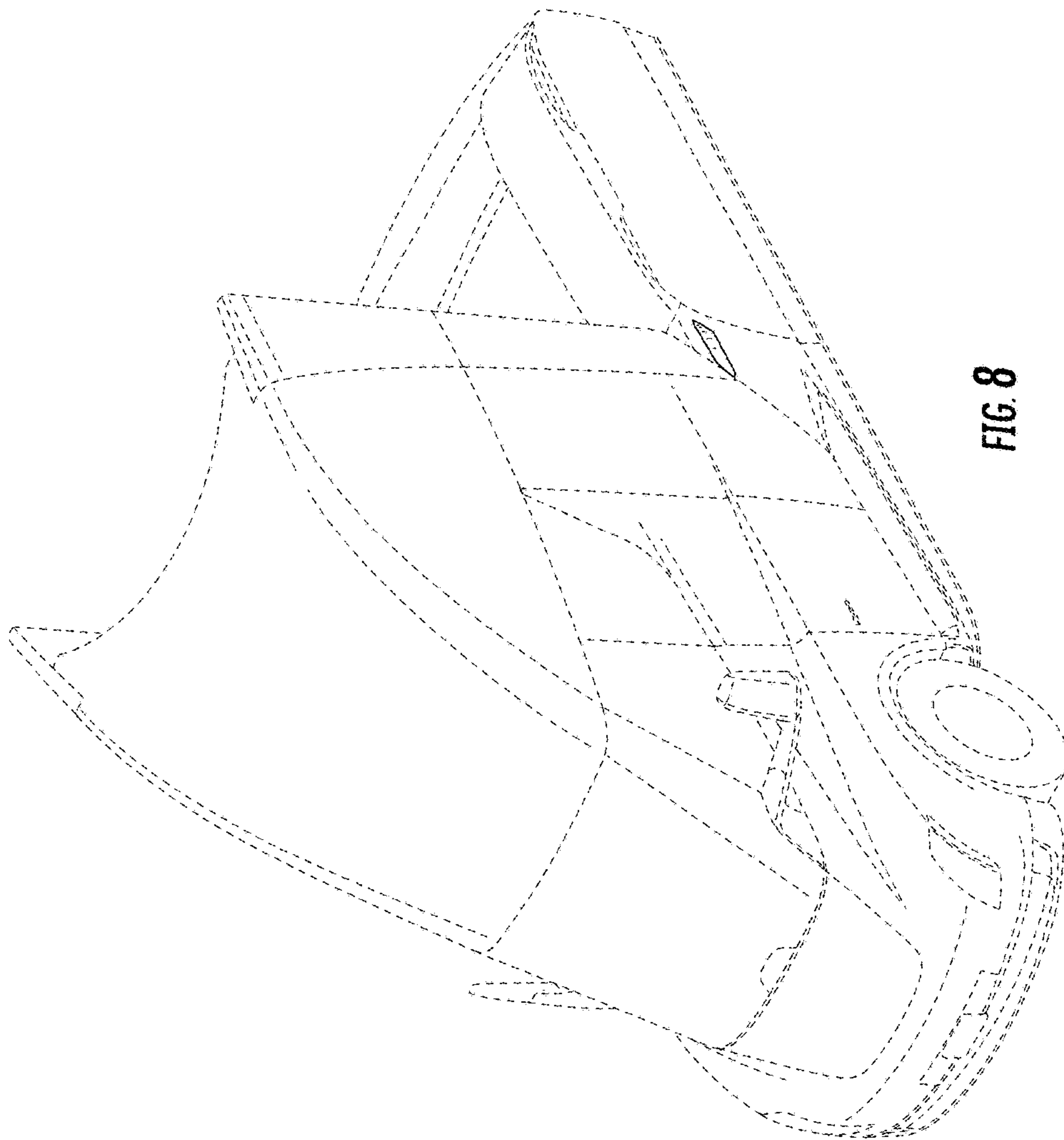

FIG. 8