



US00D854772S

(12) **United States Design Patent**  
**Ecklund et al.**

(10) **Patent No.:** **US D854,772 S**  
(45) **Date of Patent:** **\*\* Jul. 23, 2019**

- (54) **CART FOR AIR PUMP**
- (71) Applicant: **SAGE PRODUCTS, LLC**, Cary, IL (US)
- (72) Inventors: **Brian J. Ecklund**, Lakemoor, IL (US);  
**Jay R. Roberts**, Barrington, IL (US)
- (73) Assignee: **Sage Products, LLC**, Cary, IL (US)
- (\*\*) Term: **15 Years**
- (21) Appl. No.: **29/607,897**
- (22) Filed: **Jun. 16, 2017**
- (51) **LOC (11) Cl.** ..... **12-02**
- (52) **U.S. Cl.**  
USPC ..... **D34/12; D12/14**
- (58) **Field of Classification Search**  
USPC ..... D34/12, 14, 17, 27  
CPC .. B62B 3/00; B62B 3/02; B62B 3/002; B62B 3/14; B62B 3/10; B62B 3/008  
See application file for complete search history.

D730,011 S *	5/2015	McRorie	.....	D34/14
9,039,016 B2 *	5/2015	Abernethy	.....	B62B 3/02 280/6.15
9,079,600 B2 *	7/2015	Houlihan	.....	B62B 3/008
9,180,898 B2 *	11/2015	Ninomiya	.....	A61B 8/4405
D806,340 S *	12/2017	Stalter	.....	D34/14
10,118,632 B2 *	11/2018	Carzola	.....	B62B 3/004
2014/0138925 A1 *	5/2014	Ono	.....	B62B 3/02 280/35

\* cited by examiner

*Primary Examiner* — Cynthia Ramirez

(74) *Attorney, Agent, or Firm* — Foley & Lardner LLP

(57) **CLAIM**

We claim the ornamental design for aa cart for air pump, as shown and described.

**DESCRIPTION**

FIG. 1 is a rear perspective view of a cart for air pump showing our new design;  
 FIG. 2 is a rear side view of the claimed design of FIG. 1;  
 FIG. 3 is a front side view of the claimed design of FIG. 1;  
 FIG. 4 is a left side view of the claimed design of FIG. 1;  
 FIG. 5 is a right side view of the claimed design of FIG. 1;  
 FIG. 6 is a top view of the claimed design of FIG. 1; and  
 FIG. 7 is a bottom view of the claimed design of FIG. 1.  
 The broken lines in the drawings are to show portions of the cart for air pump which are not part of the claimed design.

**1 Claim, 7 Drawing Sheets**

(56) **References Cited**

U.S. PATENT DOCUMENTS

7,513,956 B2 *	4/2009	Bruno	.....	A47L 13/20 134/42
8,714,569 B2 *	5/2014	Lu	.....	F16M 13/02 280/35

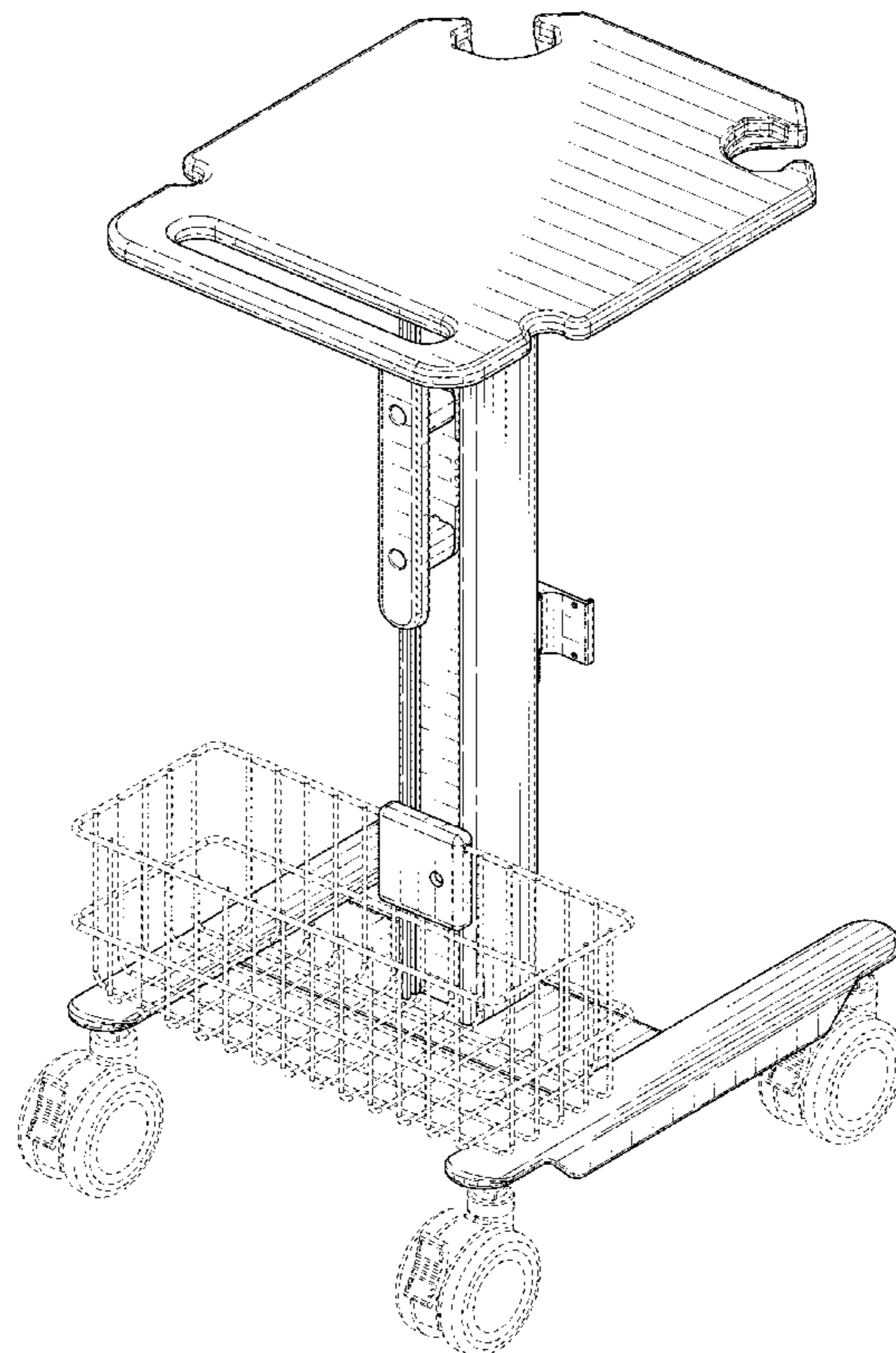

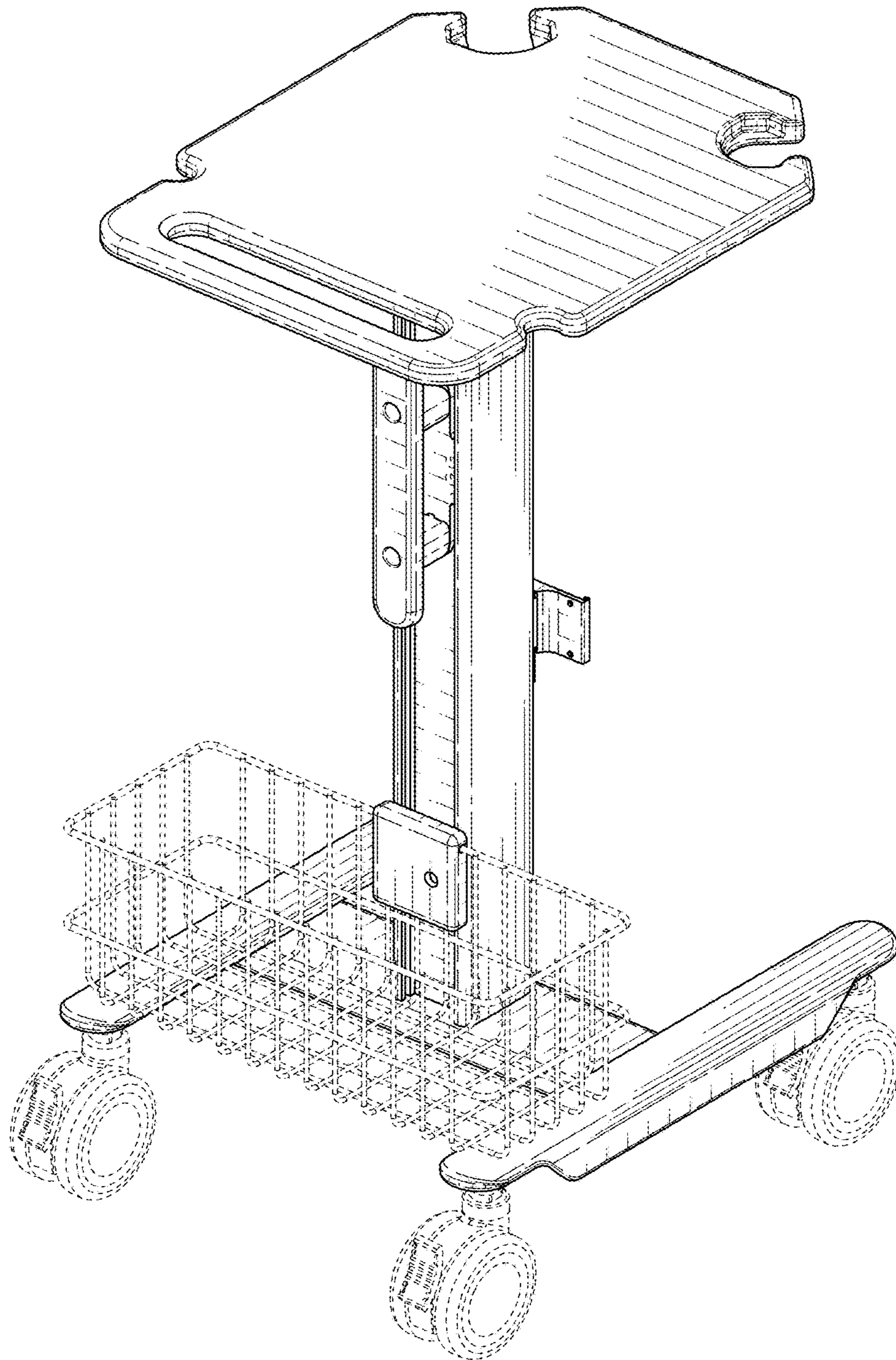

FIG. 1

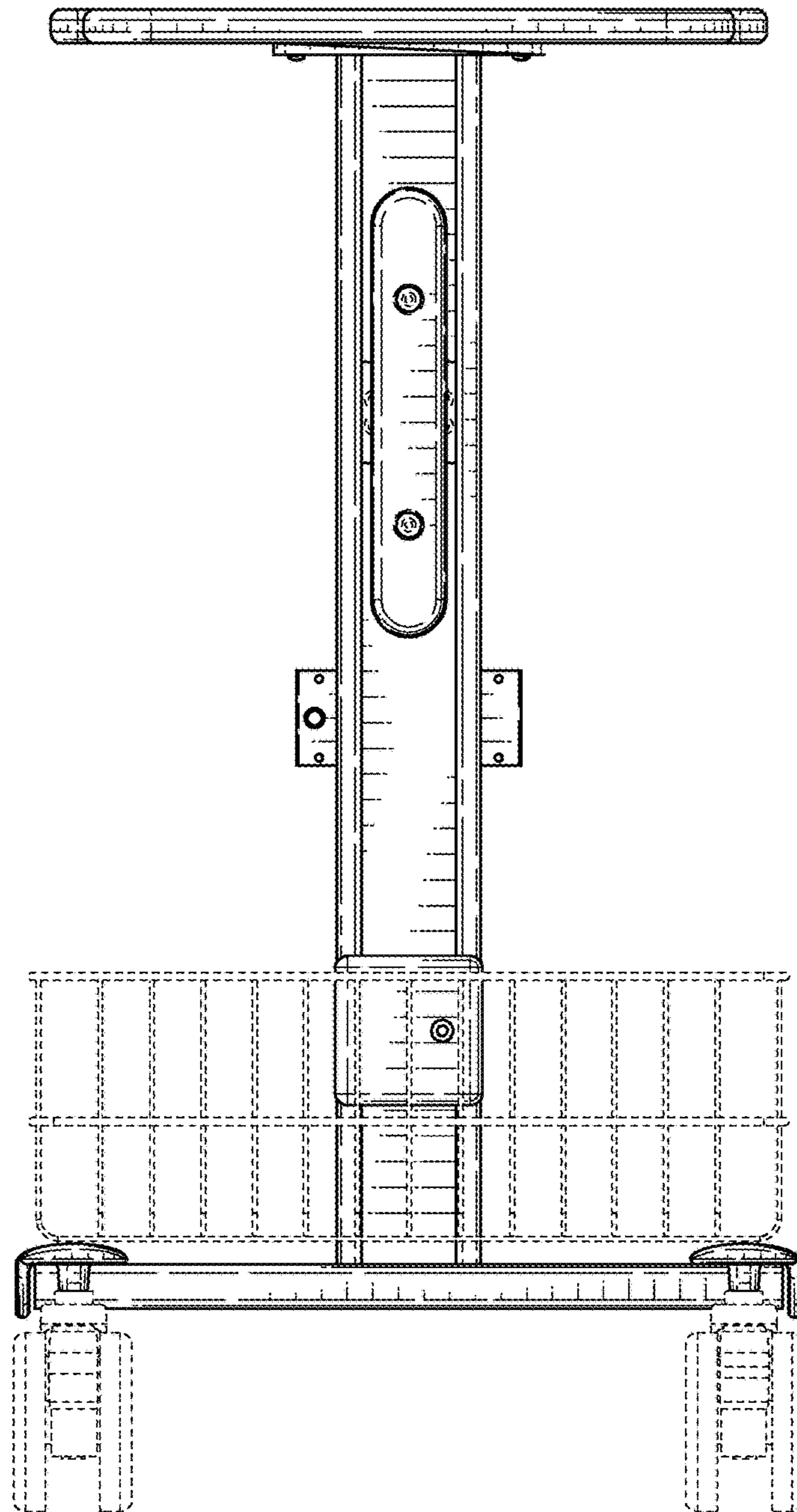

FIG. 2

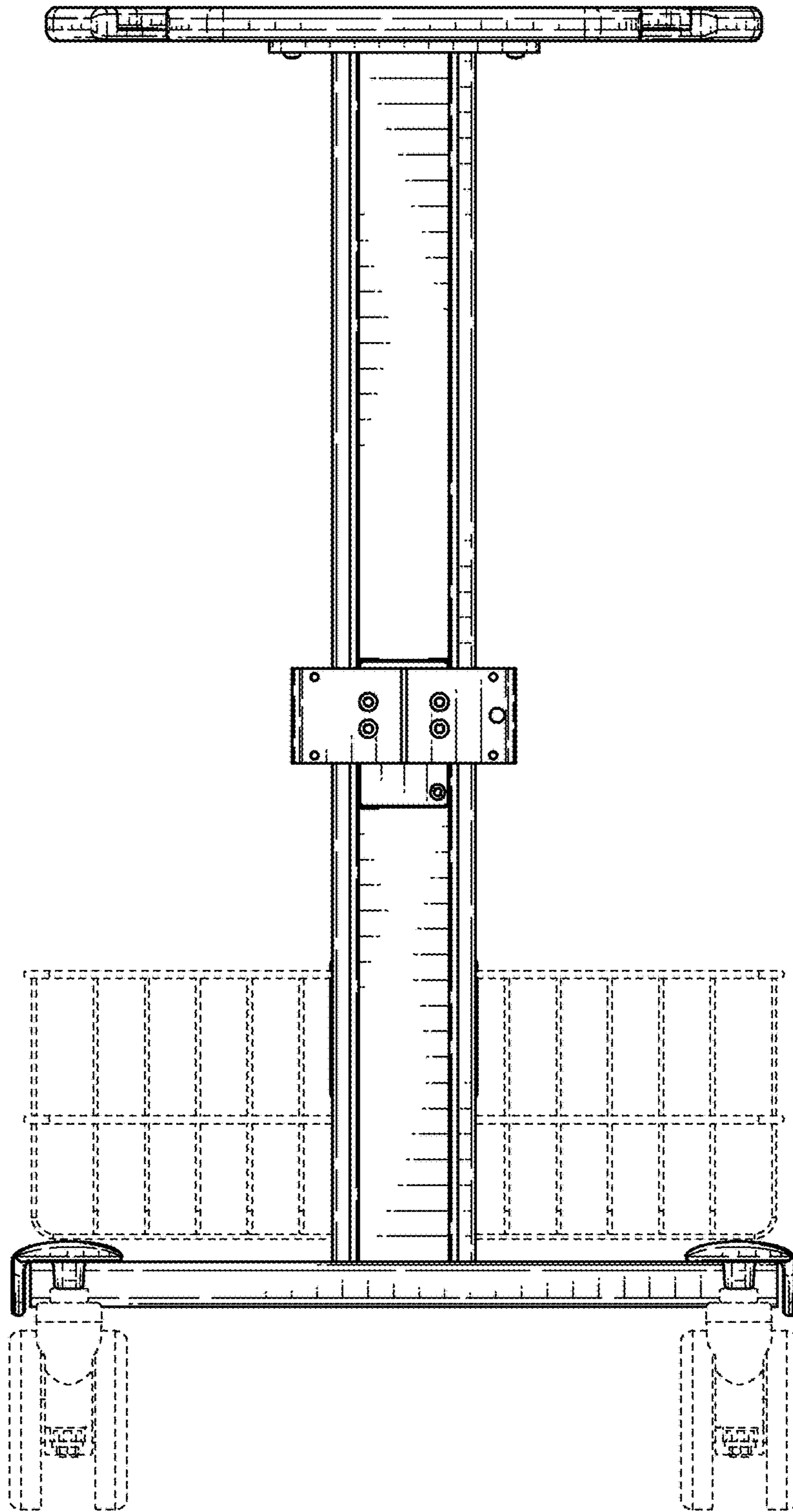

FIG. 3

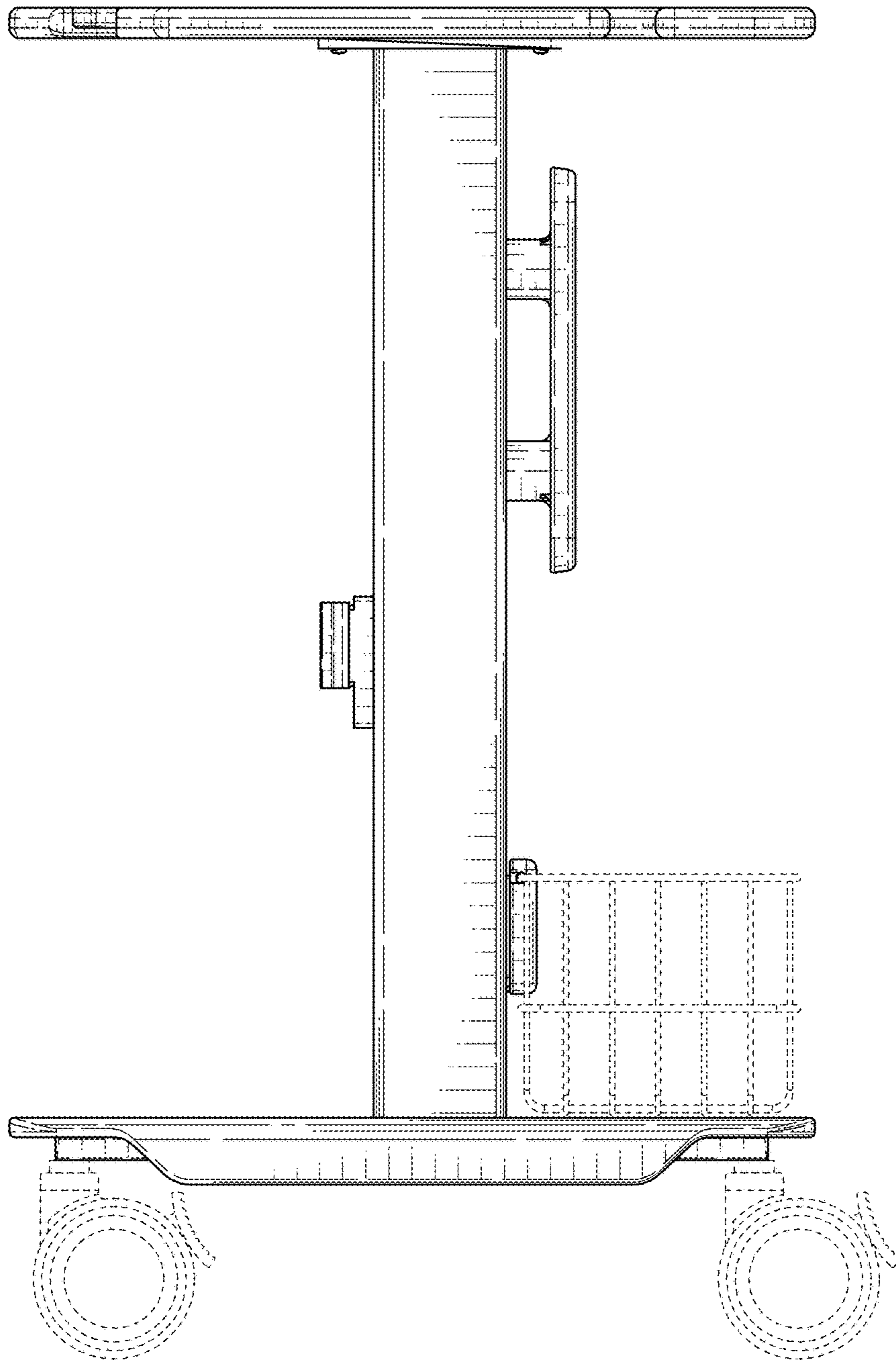

FIG. 4

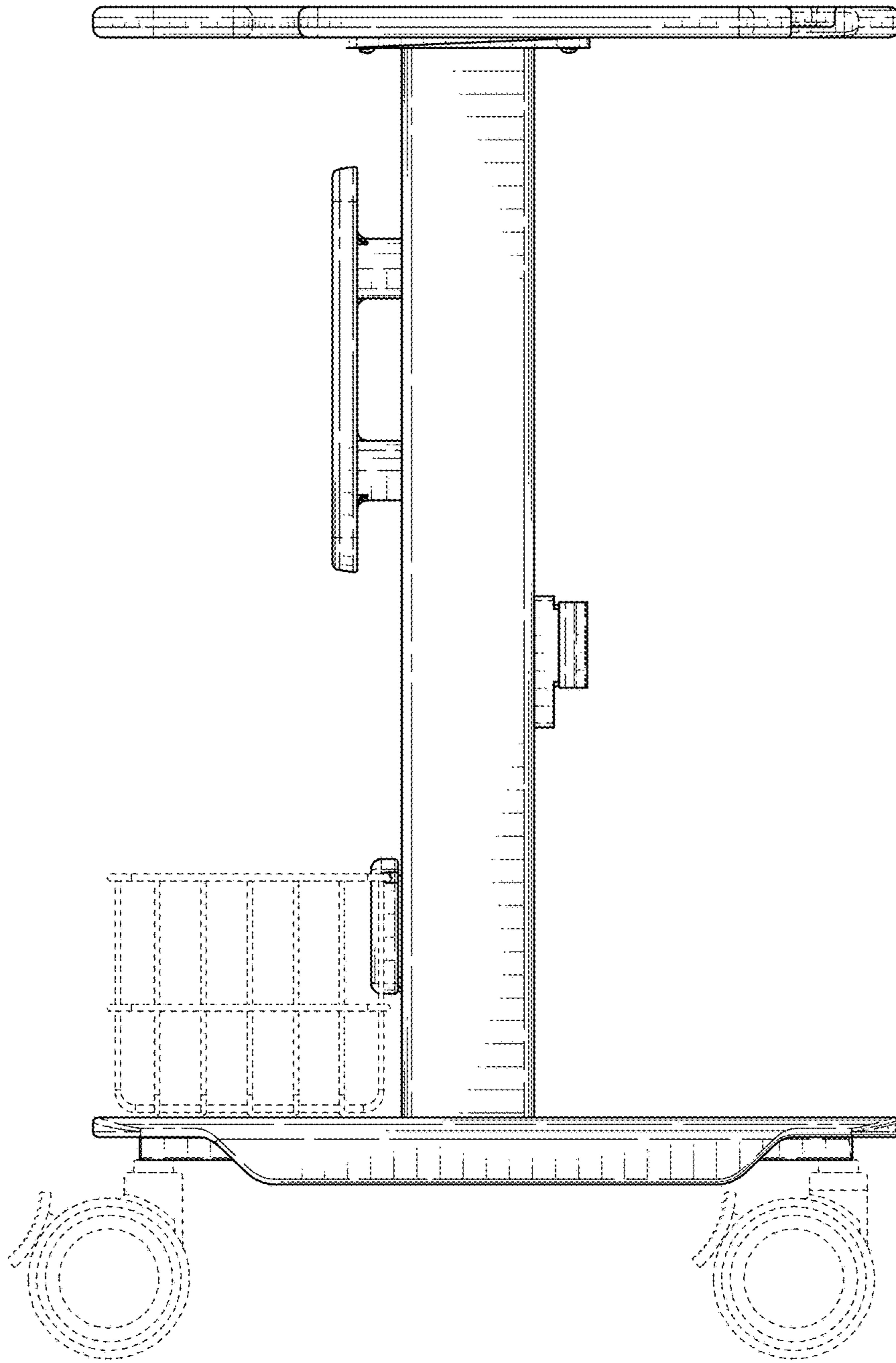

FIG. 5

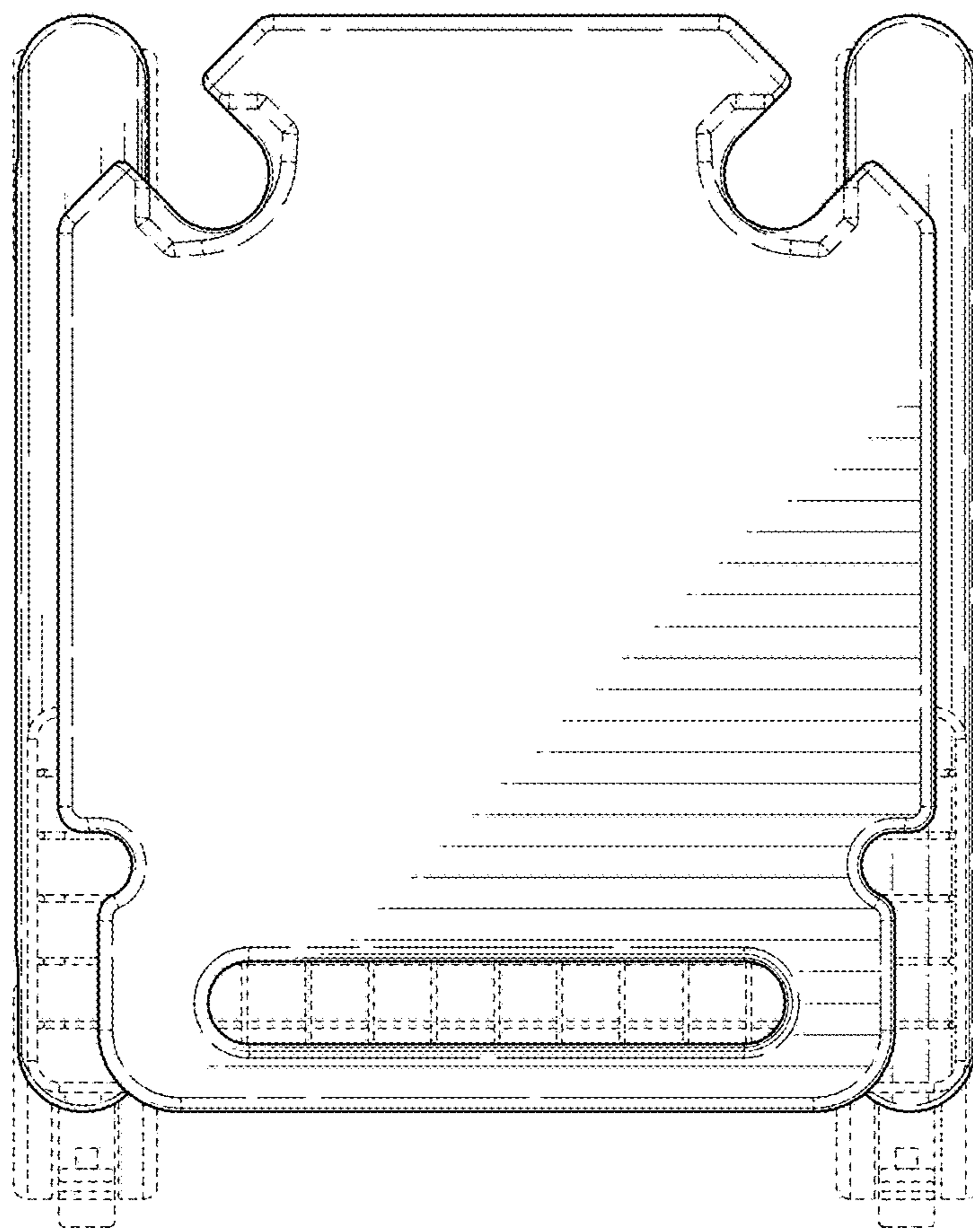

FIG. 6

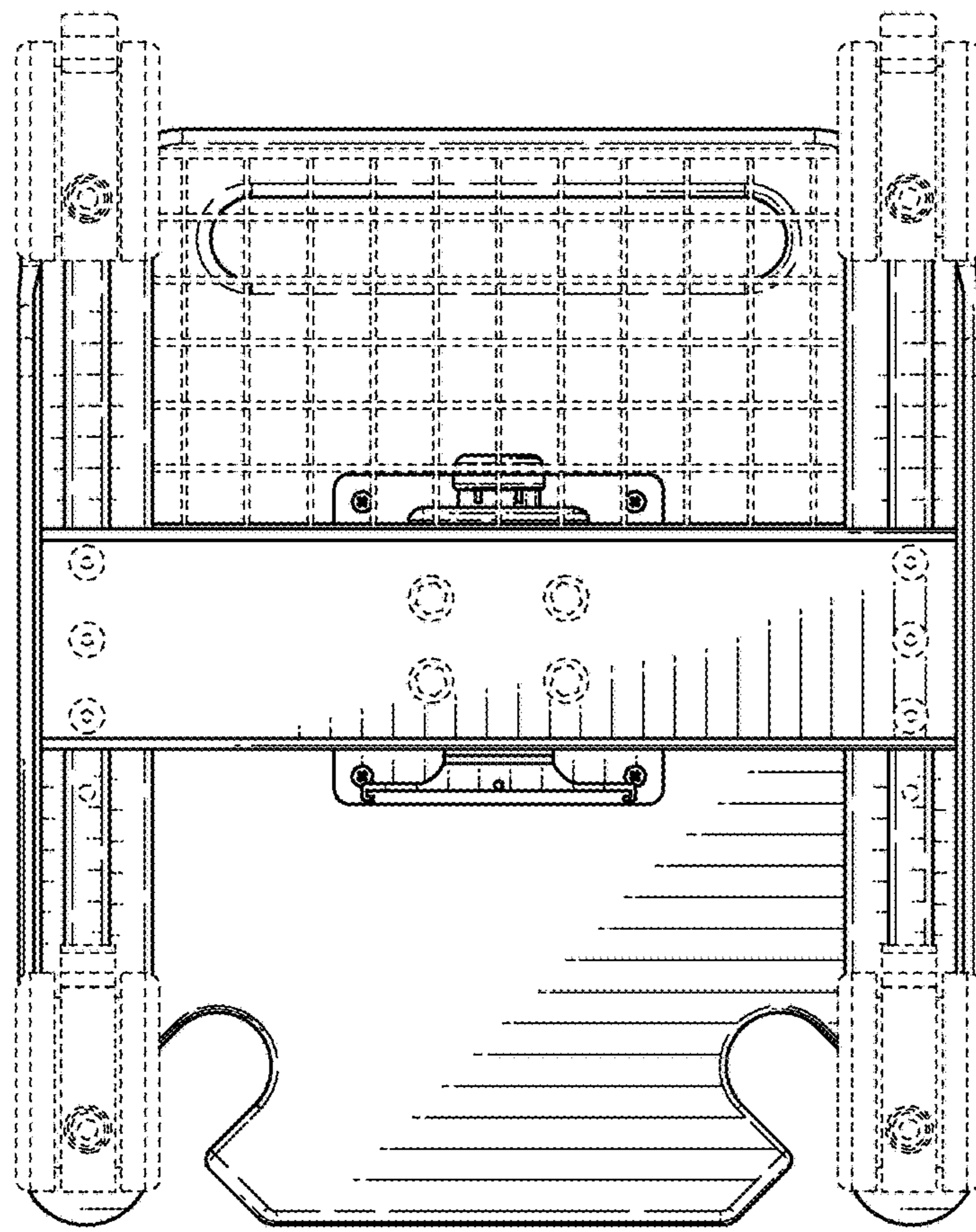

FIG. 7