

US00D854438S

(12) **United States Design Patent** (10) **Patent No.:** **US D854,438 S**
Selevan et al. (45) **Date of Patent:** **** Jul. 23, 2019**

(54) **PORTABLE ELECTRONIC FLARE** 6,549,121 B2 * 4/2003 Povey G08B 5/38
340/321
(71) Applicant: **Pi Variables, Inc.**, Tustin, CA (US) D498,164 S 11/2004 Delich
6,929,378 B2 8/2005 Wang
(72) Inventors: **James R. Selevan**, Laguna Beach, CA D515,958 S 2/2006 Dueker et al.
(US); **Daniel Joseph Selevan**, Laguna 7,088,222 B1 8/2006 Dueker et al.
Beach, CA (US) 7,106,179 B1 9/2006 Dueker et al.
7,182,479 B1 2/2007 Flood et al.
7,563,158 B2 7/2009 Haschke et al.
(**) Term: **15 Years** D631,582 S 1/2011 Hwang
D650,932 S * 12/2011 Wilson D26/37
(21) Appl. No.: **29/613,191** 8,072,345 B2 12/2011 Gallo
D654,387 S 2/2012 Wilson et al.
(22) Filed: **Aug. 8, 2017** 8,154,424 B2 4/2012 Selevan
D678,100 S 3/2013 Hwang
8,564,456 B2 10/2013 Selevan

Related U.S. Application Data

(63) Continuation-in-part of application No. 29/593,694,
filed on Feb. 10, 2017.
(51) **LOC (11) Cl.** **10-05**
(52) **U.S. Cl.**
USPC **D10/113.4**
(58) **Field of Classification Search**
USPC D10/111, 113.1, 113.4
CPC .. G08B 5/006; G08B 5/38; B60Q 7/00; F21L
4/08; E01F 9/559
See application file for complete search history.

(Continued)

OTHER PUBLICATIONS

Finley, M.D. et al., "Sequential Warning Light System for Work
Zone Lane Closures," Texas Transportation System, (2011) pp.
1-23.

(Continued)

Primary Examiner — George D. Kirschbaum
(74) *Attorney, Agent, or Firm* — Robert D. Buyan; Stout,
Uxa & Buyan, LLP

(56) **References Cited**

U.S. PATENT DOCUMENTS

3,500,378 A 3/1970 Pickering et al.
3,787,867 A 1/1974 Dodge et al.
4,132,983 A 1/1979 Shapiro
4,345,305 A 8/1982 Kolm et al.
4,827,245 A 5/1989 Lipman
4,841,278 A 6/1989 Tezuka et al.
5,294,924 A 3/1994 Dydzyk
5,438,495 A 8/1995 Ahlen et al.
5,754,124 A 5/1998 Daggett et al.
5,785,410 A * 7/1998 Branson, Sr. E01F 9/559
362/153
5,831,522 A * 11/1998 Weed B60Q 7/00
340/473
6,486,797 B1 11/2002 Laidman

(57) **CLAIM**

The ornamental designs for portable electronic flare, as
shown.

DESCRIPTION

FIG. 1 is a top, right perspective view of a portable elec-
tronic flare showing our new design; and,
FIG. 2, is a bottom, left perspective view thereof.
The broken lines depict unclaimed environmental subject
matter.

1 Claim, 2 Drawing Sheets

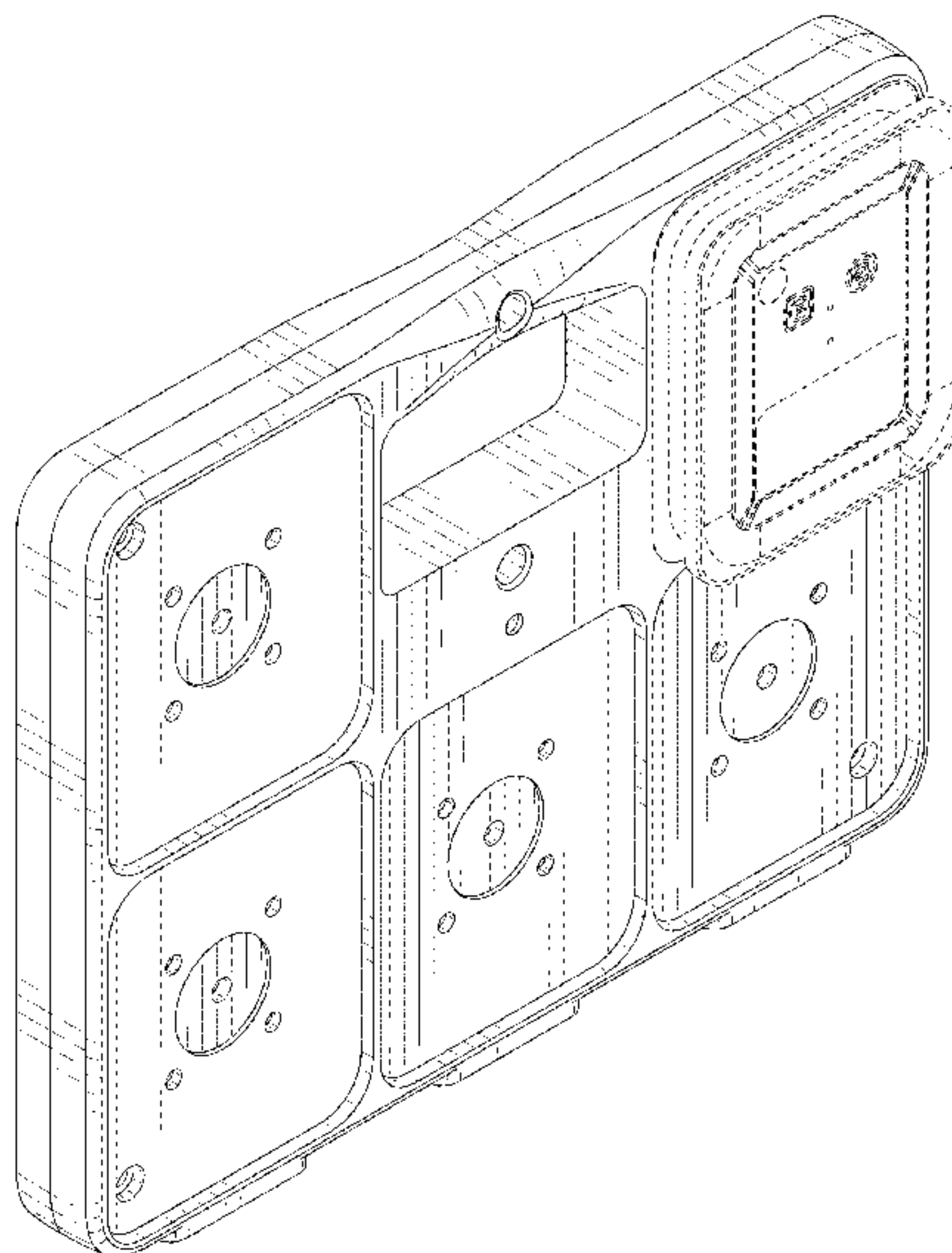

(56)

References Cited

U.S. PATENT DOCUMENTS

8,579,460 B2 * 11/2013 Wilson F21L 4/08
 362/183
 8,602,584 B2 12/2013 Ghafoori et al.
 9,437,109 B1 9/2016 Stafford et al.
 9,835,319 B2 * 12/2017 Selevan G08B 5/006
 2002/0036908 A1 3/2002 Pederson
 2002/0154787 A1 10/2002 Rice et al.
 2002/0159251 A1 10/2002 Hart
 2002/0175831 A1 11/2002 Bergan et al.
 2003/0164666 A1 9/2003 Crunk
 2004/0056779 A1 3/2004 Rast
 2004/0100396 A1 5/2004 Antico et al.
 2005/0040970 A1 2/2005 Hutchins et al.
 2005/0210722 A1 9/2005 Graef et al.
 2005/0248299 A1 11/2005 Chemel et al.
 2006/0072306 A1 4/2006 Woodyard
 2006/0104054 A1 5/2006 Coman
 2007/0038743 A1 2/2007 Hellhake et al.
 2007/0099625 A1 5/2007 Rosenfeld
 2007/0153520 A1 7/2007 Curran et al.
 2007/0194906 A1 8/2007 Sink
 2007/0222640 A1 9/2007 Guelzow et al.
 2008/0042866 A1 2/2008 Morse et al.

2008/0091304 A1 4/2008 Ozick et al.
 2008/0242220 A1 10/2008 Wilson et al.
 2009/0115336 A1 5/2009 Wang
 2009/0187300 A1 7/2009 Everitt
 2011/0249430 A1 10/2011 Stamatatos et al.
 2011/0249688 A1 10/2011 Liu
 2012/0256765 A1 10/2012 Selevan
 2012/0277934 A1 11/2012 Ohtomo et al.
 2012/0287611 A1 11/2012 Wilson et al.
 2013/0221852 A1 8/2013 Bowers et al.
 2013/0260695 A1 10/2013 Wang
 2013/0271294 A1 10/2013 Selevan
 2013/0293396 A1 11/2013 Selevan
 2014/0126187 A1 5/2014 Bennett et al.
 2014/0210373 A1 7/2014 Baret

OTHER PUBLICATIONS

Sun, C. et al., "Cost-Benefit Analysis of Sequential Warning Lights in Nighttime Work Zone Tapers", University of Missouri, Report to the Smart Work Zone Deployment Initiative, Jun. 6, 2011.
 Internet Website Screen Capture, www.empco-lite.com; Sep. 6, 2010.

* cited by examiner

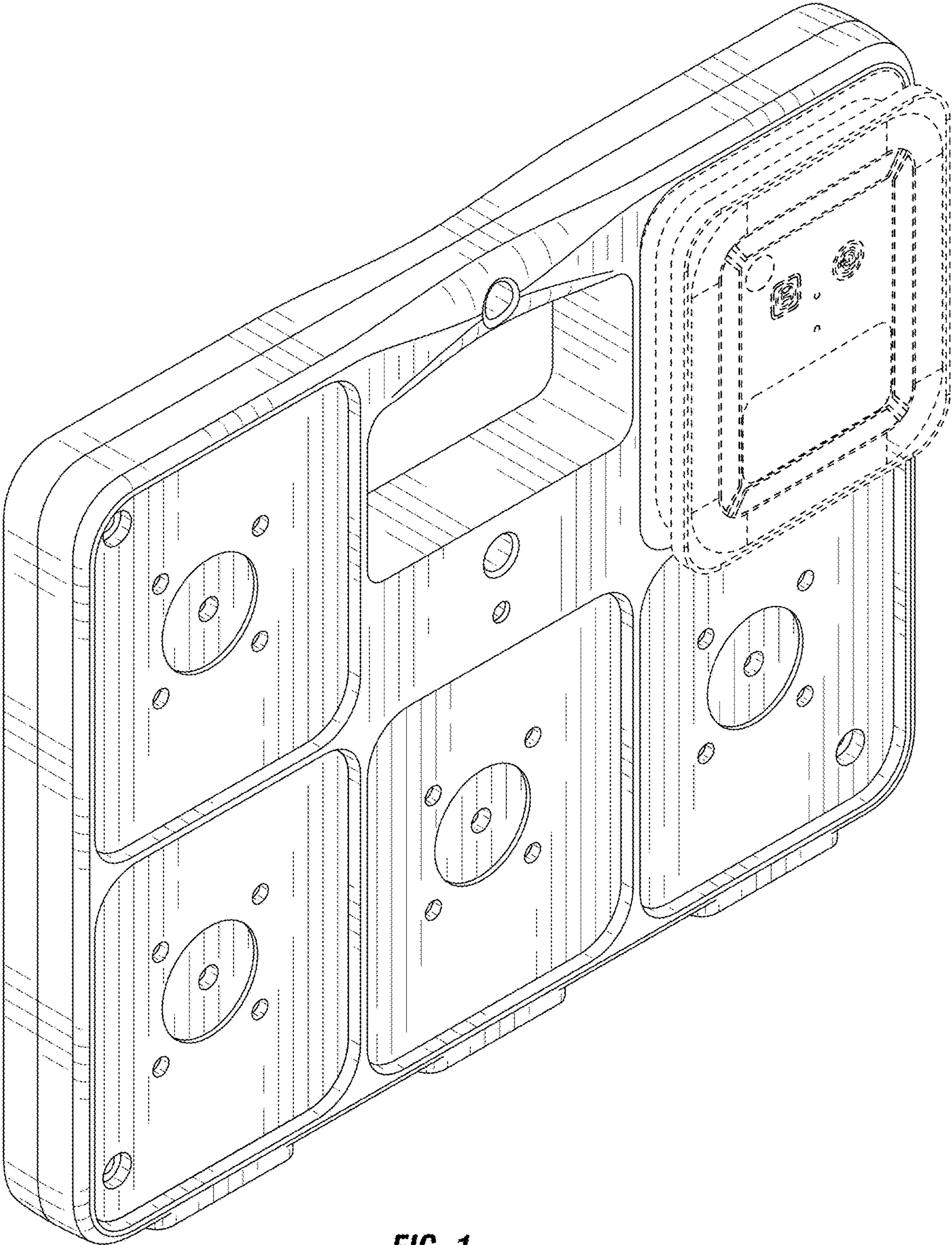

FIG. 1

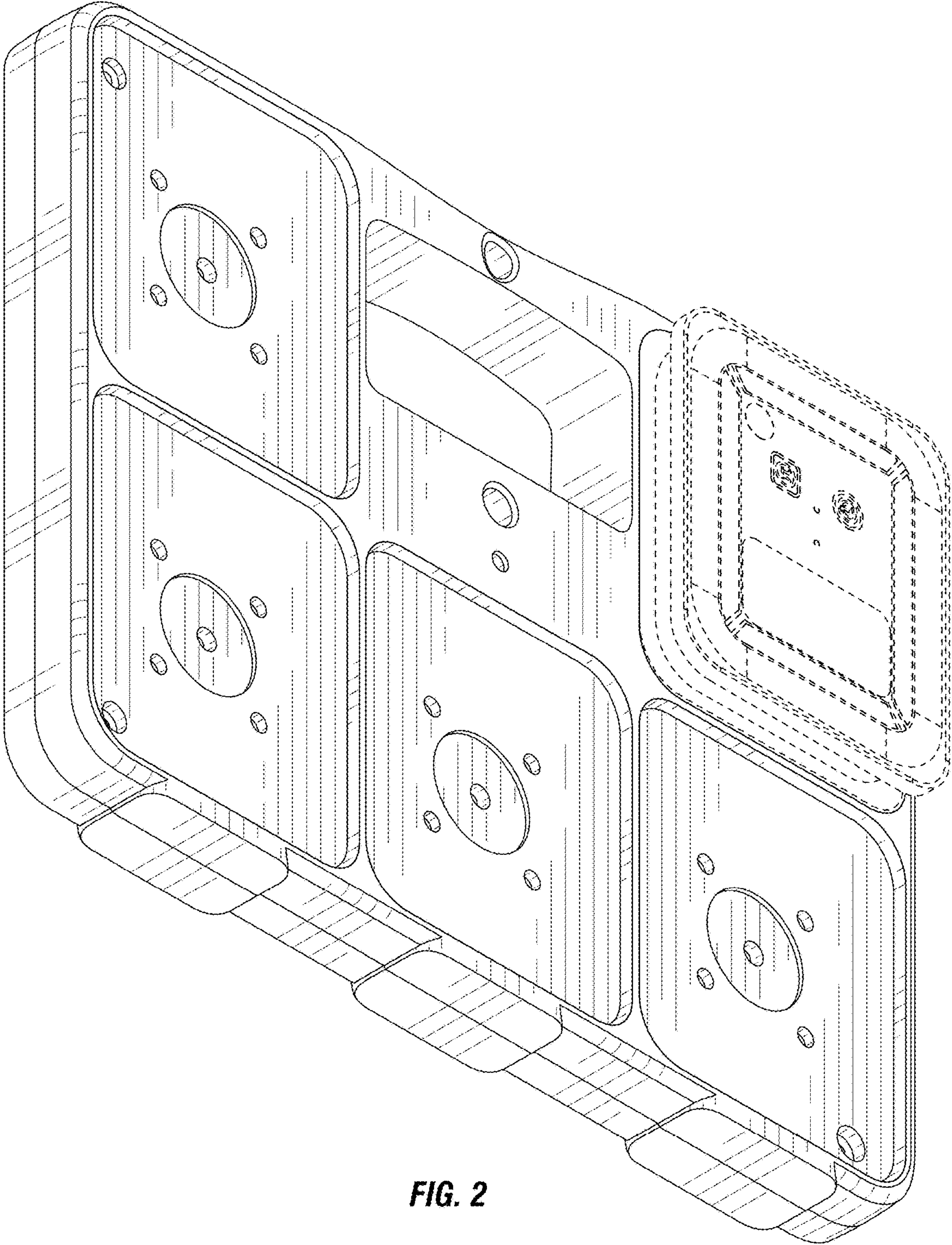

FIG. 2