



US00D853890S

(12) **United States Design Patent**
Sgreva

(10) **Patent No.:** **US D853,890 S**
(45) **Date of Patent:** **** Jul. 16, 2019**

(54) **PEDAL CRANK ASSEMBLY FOR CYCLES OR MOTORCYCLES**

(71) Applicant: **CAMPAGNOLO S.r.l.**, Vicenza (IT)

(72) Inventor: **Nicola Sgreva**, Arcugnano (IT)

(73) Assignee: **Campagnolo S.r.l.**

(**) Term: **15 Years**

(21) Appl. No.: **29/613,455**

(22) Filed: **Aug. 10, 2017**

(30) **Foreign Application Priority Data**

Feb. 13, 2017 (EM) 003752294-0002

(51) **LOC (11) Cl.** **12-11**

(52) **U.S. Cl.**
USPC **D12/123**

(58) **Field of Classification Search**
USPC D12/111, 122-127
CPC F16H 7/06; F16H 55/30; F16H 55/303;
F16F 55/12; B62M 9/105
See application file for complete search history.

(56) **References Cited**

U.S. PATENT DOCUMENTS

D102,378 S *	12/1936	Kraeft	D12/125
D299,221 S *	1/1989	Borromeo	D12/123
D356,526 S *	3/1995	Burns	D12/123
5,911,792 A *	6/1999	Jaimes	B62M 1/10 74/594.1
D485,791 S *	1/2004	Mombrinie	D12/123
D520,920 S *	5/2006	Okada	D12/123
D532,342 S *	11/2006	Arakawa	D12/123
D553,055 S *	10/2007	Tokumoto	D12/123
D555,048 S *	11/2007	Hanamura	D12/123
D580,303 S *	11/2008	Okada	D12/123

D600,166 S *	9/2009	Tokumoto	D12/123
D607,784 S *	1/2010	Gisbert	D12/123
D675,549 S *	2/2013	Noborio	D12/123
D749,988 S *	2/2016	Sgreva	D12/123
D751,950 S *	3/2016	Sgreva	D12/123
D756,270 S *	5/2016	Sgreva	D12/123
D756,271 S *	5/2016	Sgreva	D12/123

FOREIGN PATENT DOCUMENTS

TW D150390 S1 11/2012

OTHER PUBLICATIONS

Taiwanese Notice of Allowance, dated Mar. 15, 2018 for Application No. 106304568, with English translation.

* cited by examiner

Primary Examiner — Darlington Ly

(74) *Attorney, Agent, or Firm* — Volpe and Koenig, P.C.

(57) **CLAIM**

The ornamental design for a pedal crank assembly for cycles or motorcycles, as shown and described.

DESCRIPTION

FIG. 1 is a top and front perspective view of a pedal crank assembly for cycles or motorcycles showing my new design; FIG. 2 is a top plan view thereof; FIG. 3 is a bottom plan view thereof; FIG. 4 is a front elevation view thereof; FIG. 5 is a rear elevation view thereof; FIG. 6 is a left side elevation view thereof; and, FIG. 7 is a right side elevation view thereof.

The broken lines in the drawings illustrate portions of the pedal crank assembly for cycles and motorcycles that form no part of the claimed design.

1 Claim, 6 Drawing Sheets

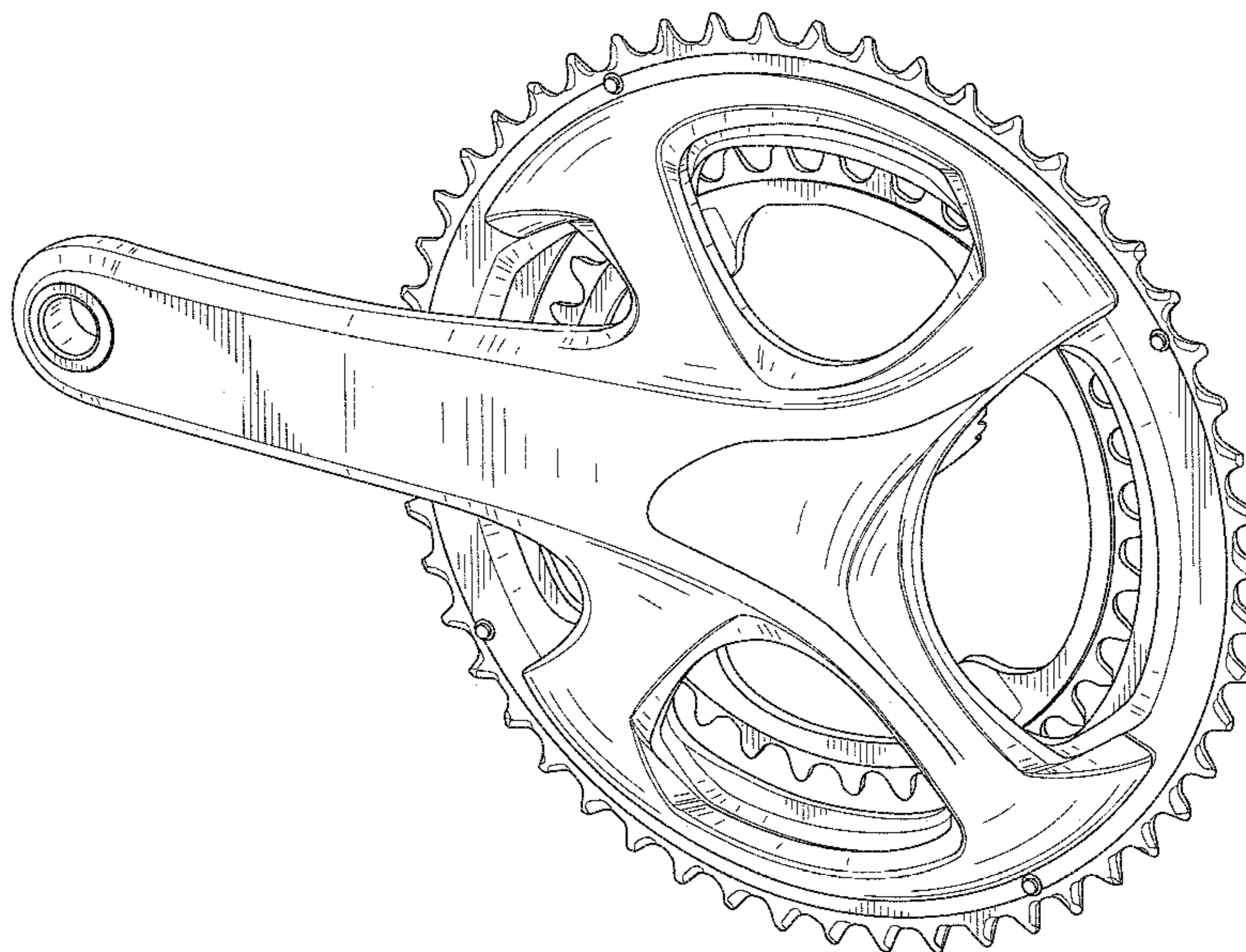

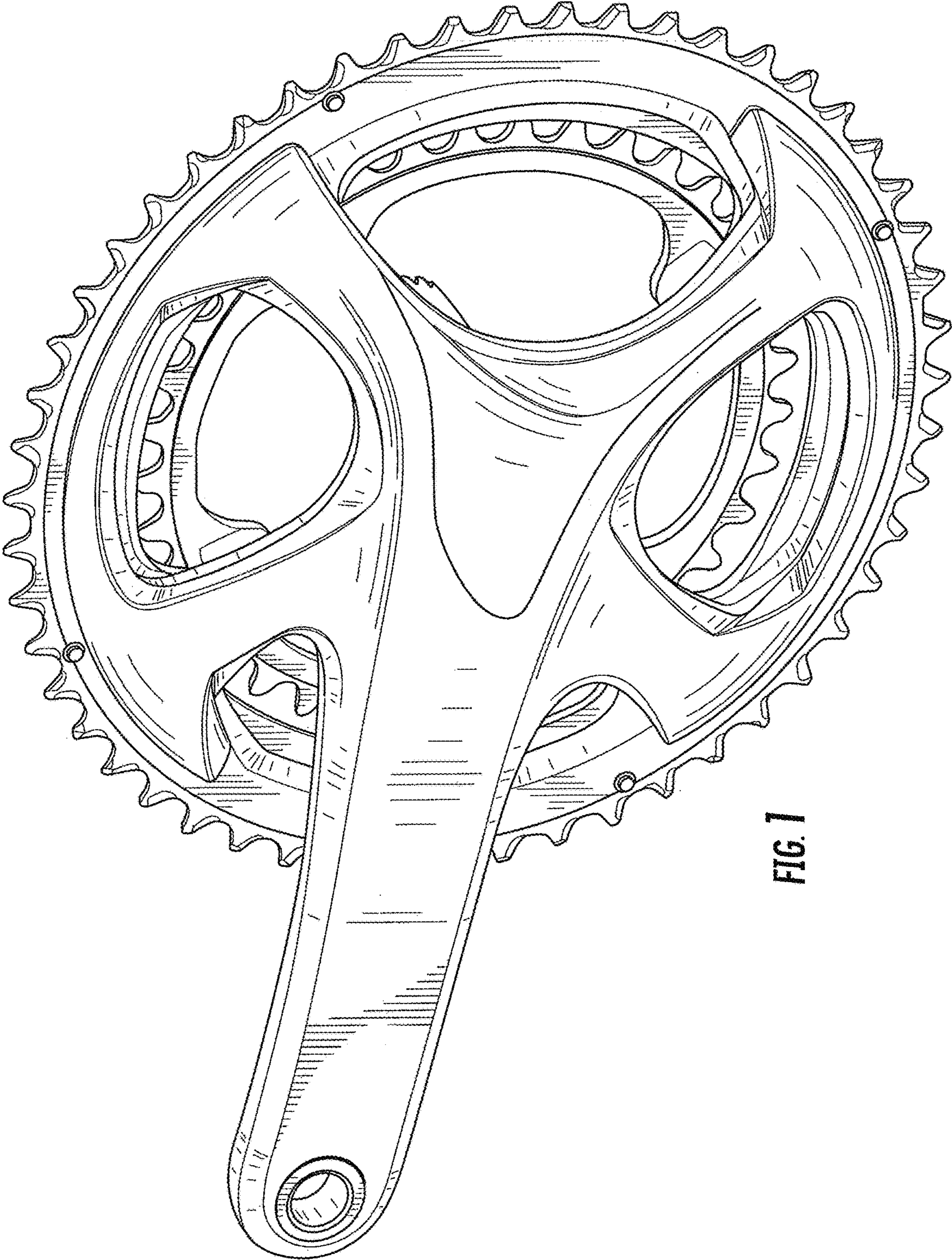

FIG. 1

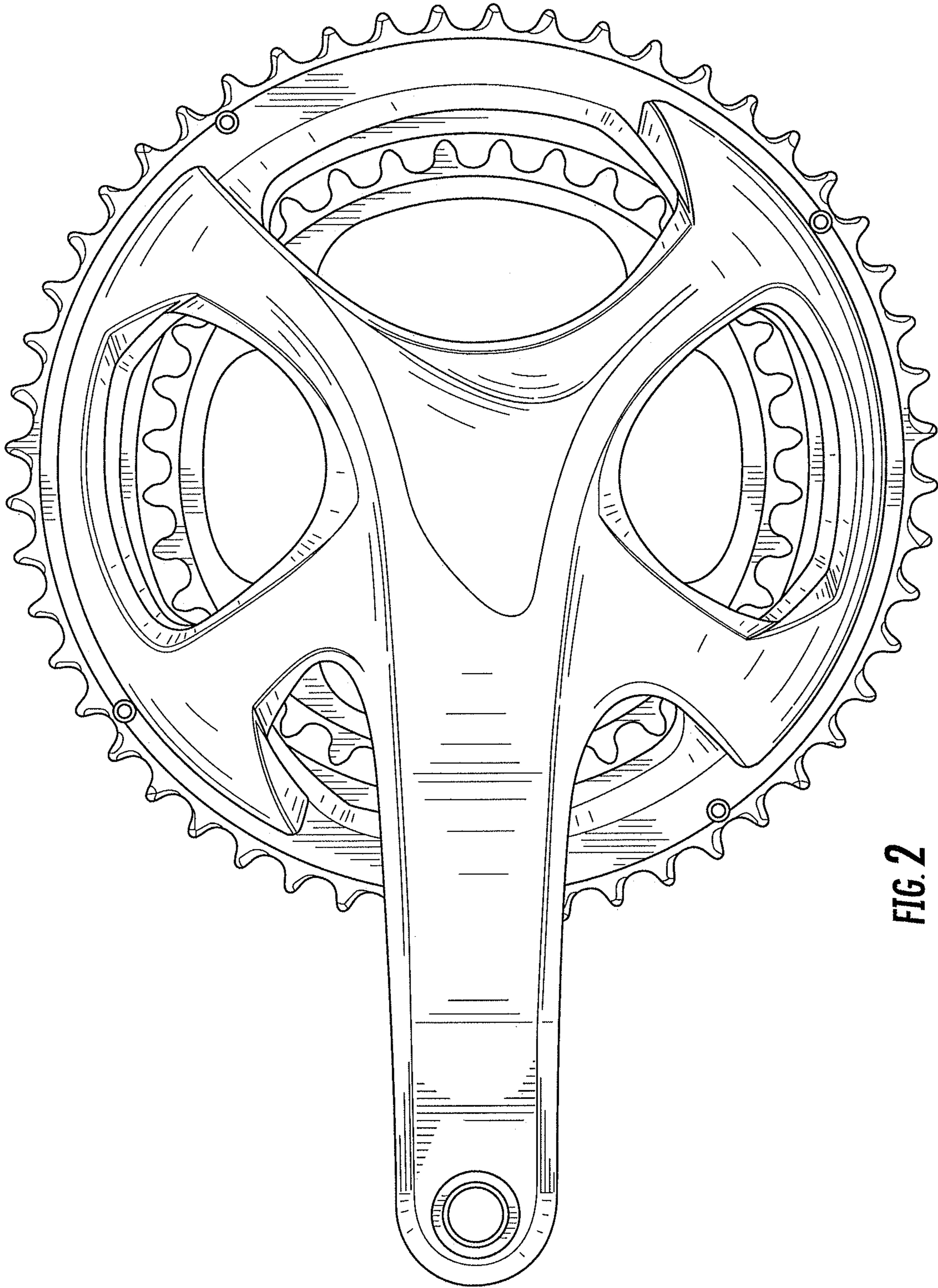

FIG. 2

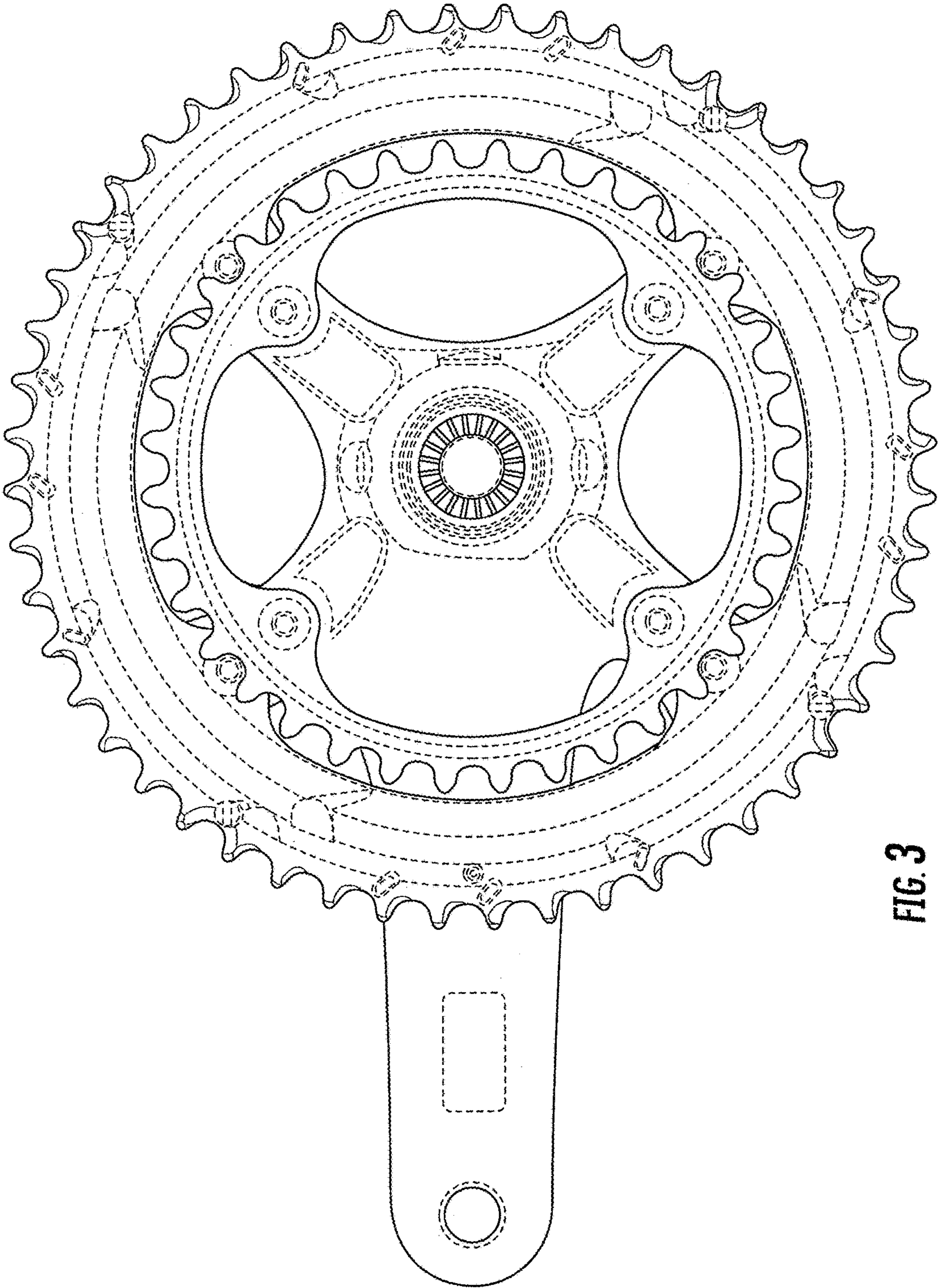

FIG. 3

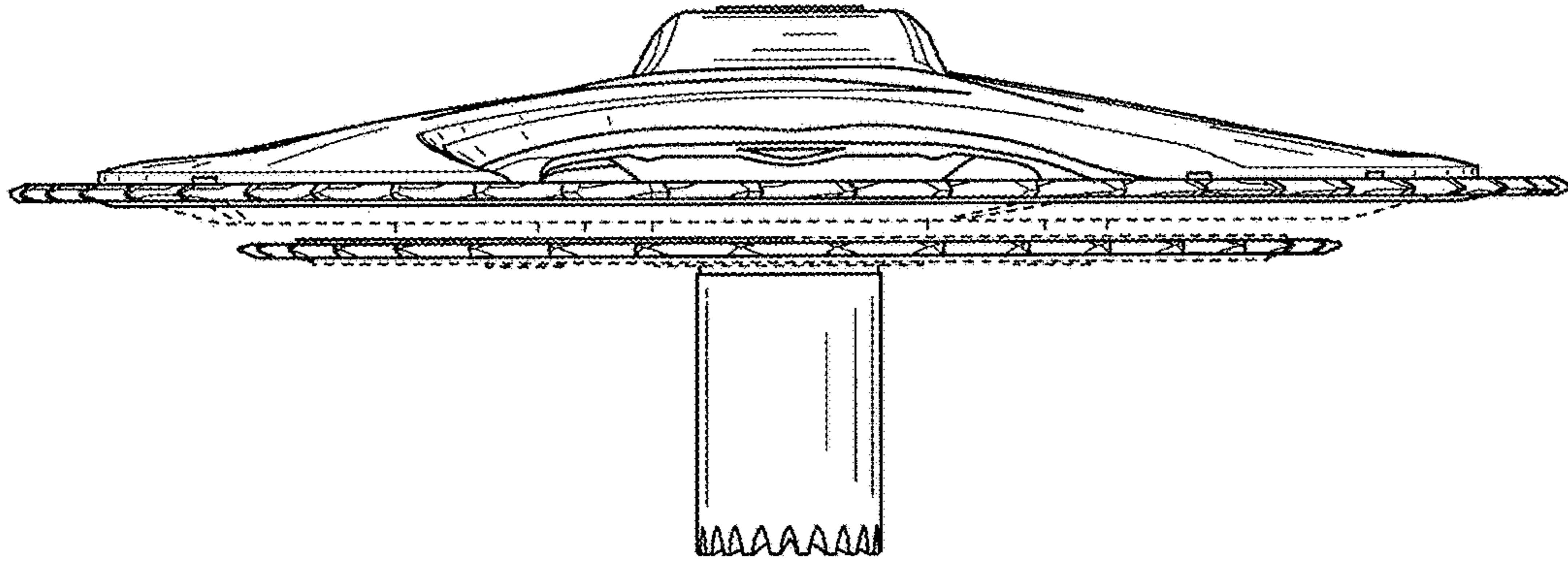

FIG. 4

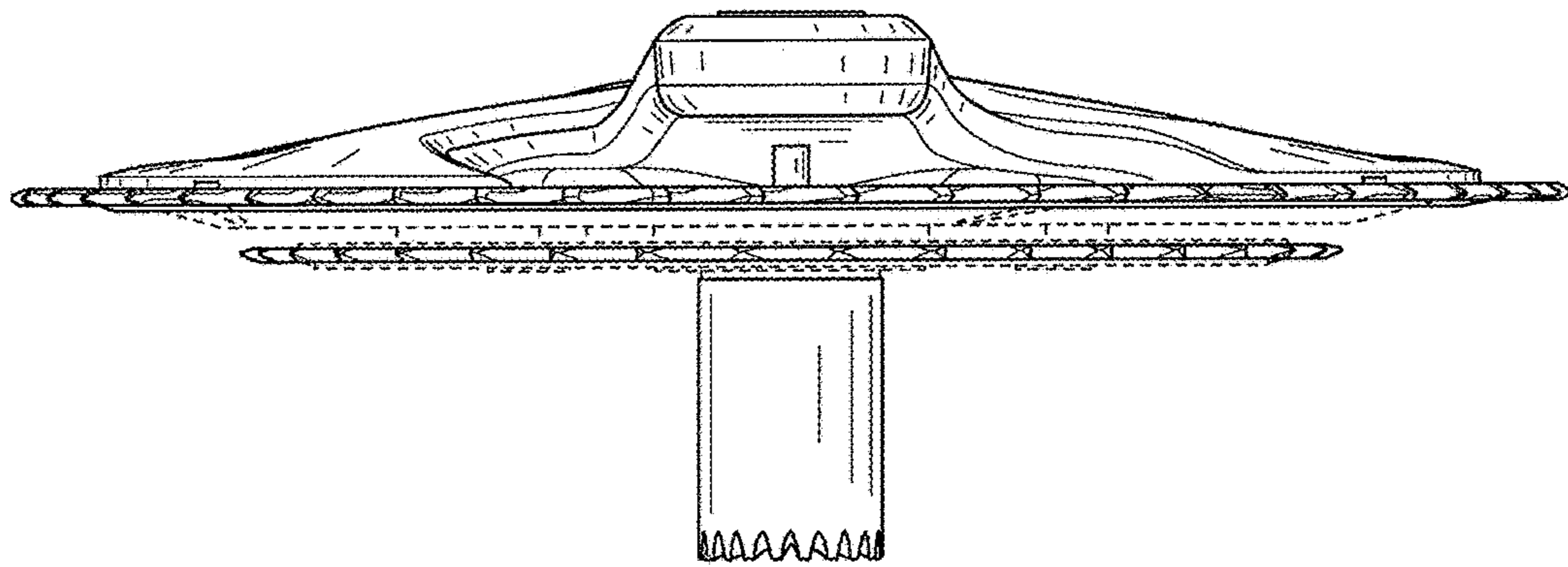

FIG. 5

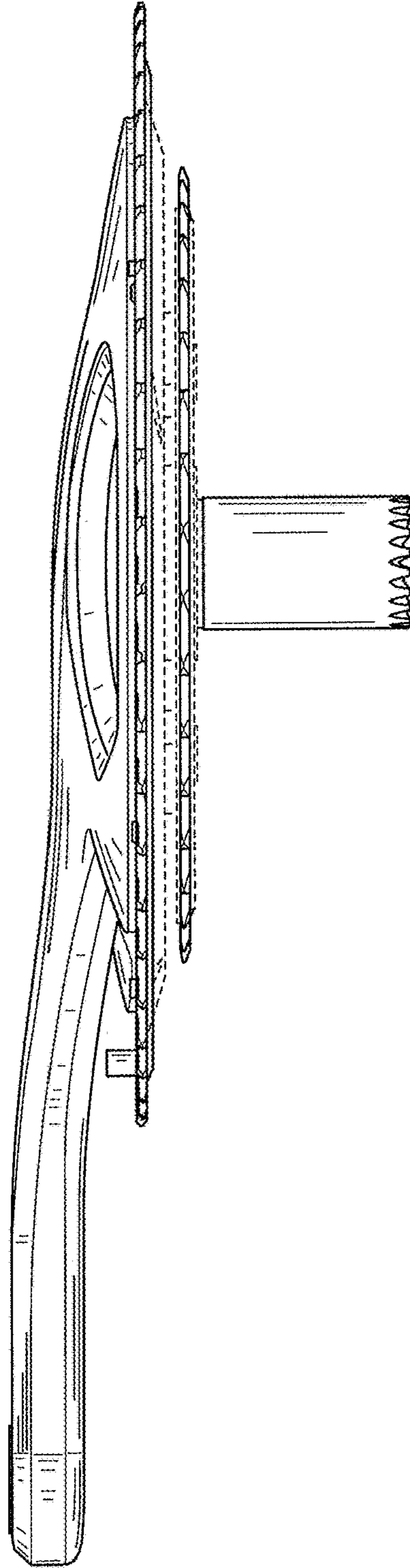

FIG. 6

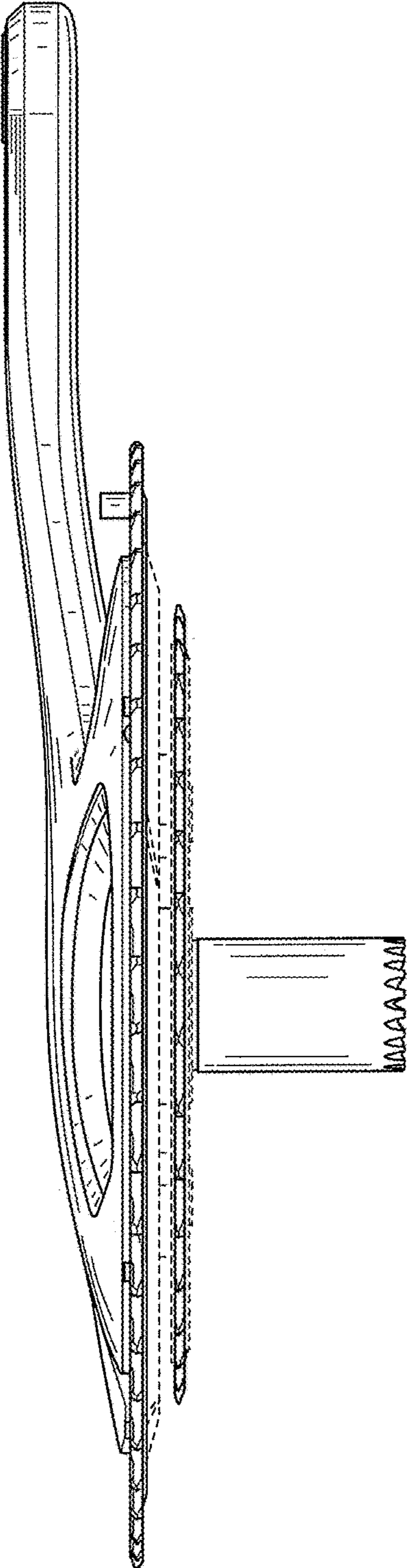

FIG. 7