



US00D853594S

(12) **United States Design Patent** (10) **Patent No.:** **US D853,594 S**  
**Momme et al.** (45) **Date of Patent:** **\*\* Jul. 9, 2019**

(54) **ELECTRIC POWER TRANSMISSION LINE SUPPORT TOWER WITH INSULATOR ASSEMBLY**

D226,008 S \* 1/1973 Donovan ..... D25/127  
D242,765 S 12/1976 Patrick  
4,219,742 A 8/1980 Ponder  
4,458,102 A 7/1984 White  
D369,785 S 5/1996 Cote  
D381,096 S 7/1997 Tallon  
D387,881 S 12/1997 Tallon  
D402,379 S 12/1998 Mimram  
D610,087 S 2/2010 Johnson

(71) Applicant: **BOLD Transmission, LLC**, Columbus, OH (US)

(72) Inventors: **Jeffrey Eugene Momme**, Westerville, OH (US); **Meihuan Zhu Fulk**, Lewis Center, OH (US)

(73) Assignee: **BOLD TRANSMISSION, LLC**, Columbus, OH (US)

(\*\*) Term: **15 Years**

(21) Appl. No.: **29/634,702**

(22) Filed: **Jan. 24, 2018**

(51) **LOC (11) Cl.** ..... **25-01**

(52) **U.S. Cl.**  
USPC ..... **D25/127**; D13/110

(58) **Field of Classification Search**  
USPC ..... D25/126, 127, 128, 129, 131, 133, 134, D25/199; D13/110

CPC .. H02G 7/02; H02G 7/04; H02G 7/05; H02G 7/053; H02G 7/12; H02G 7/20; H02G 7/205; H02G 7/22; H02G 9/02; H02G 11/006; E04H 12/10; E04H 12/24

See application file for complete search history.

(56) **References Cited**

**U.S. PATENT DOCUMENTS**

3,002,043 A 9/1961 Jenner et al.  
3,316,342 A \* 4/1967 Cofer ..... H02G 7/20  
174/148  
D211,089 S 5/1968 Dreyfuss  
D211,177 S \* 5/1968 Elmshurst, III ..... D25/134  
D211,995 S \* 8/1968 Elmshurst, III ..... D25/127  
3,439,107 A 4/1969 Scott  
3,509,678 A 5/1970 Dake  
3,571,991 A 3/1971 Doocy et al.  
3,603,717 A 9/1971 Scott

**FOREIGN PATENT DOCUMENTS**

EP 1128513 A1 8/2001  
WO 1994026013 A1 11/1994  
WO 2003077393 A1 9/2003

**OTHER PUBLICATIONS**

Alexandrov, G.N. et al., Overhead Line Designing in View of Environmental Constraints, Compact Overhead Lines, CIGRE, 1998.

(Continued)

*Primary Examiner* — Daniel D Bui

(74) *Attorney, Agent, or Firm* — Standley Law Group LLP

(57) **CLAIM**

The ornamental design for an electric power transmission line support tower with insulator assembly, as shown and described.

**DESCRIPTION**

FIG. 1 is a perspective view of an electric power transmission line support showing our new design;  
FIG. 2 is a front elevational view thereof, the rear elevational view being a mirror image;  
FIG. 3 is a right side elevational view thereof, the left side elevational view being a mirror image;  
FIG. 4 is a top plan view thereof; and,  
FIG. 5 is a bottom plan view thereof.

**1 Claim, 4 Drawing Sheets**

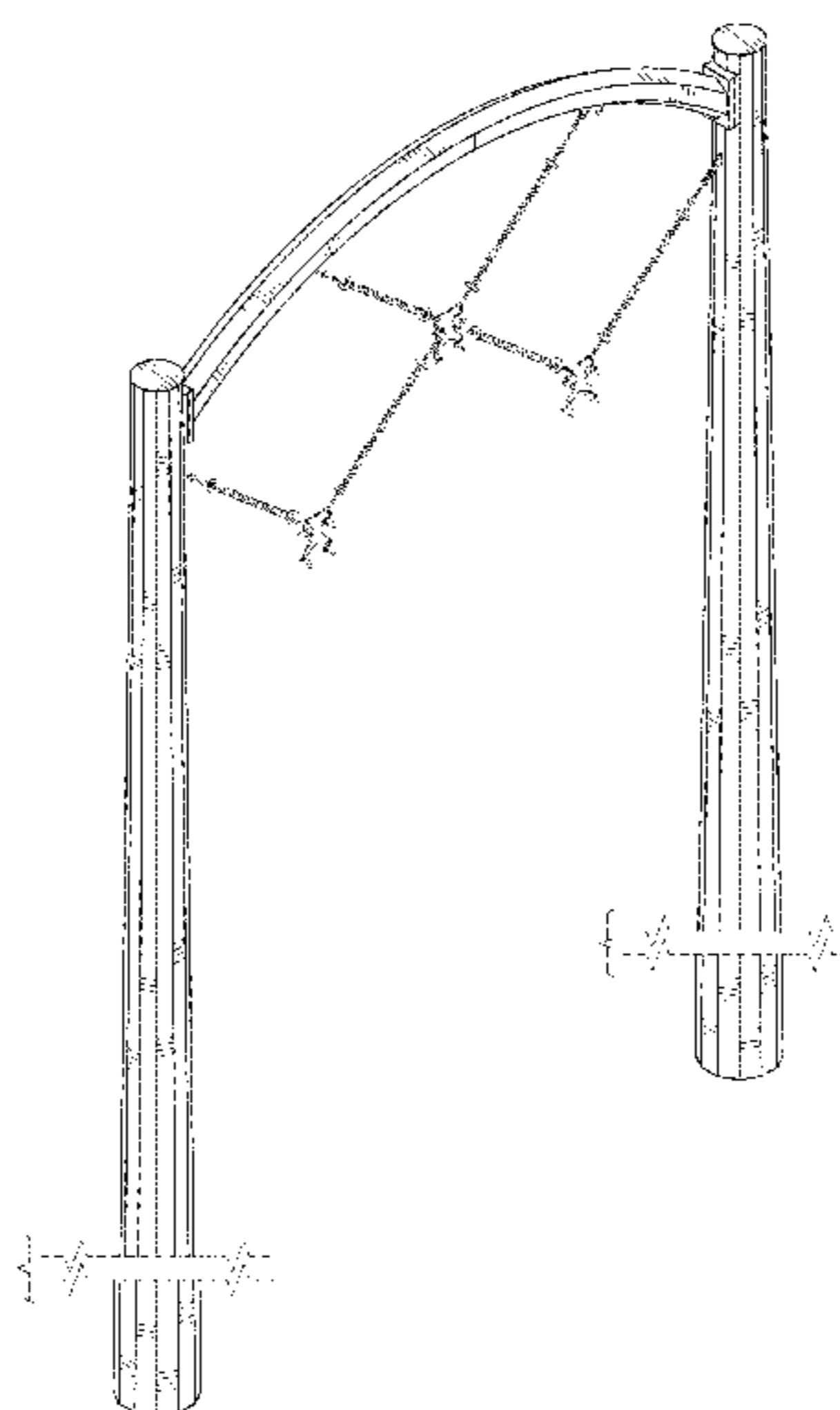

(56)

**References Cited**

## U.S. PATENT DOCUMENTS

D613,686 S	4/2010	Mueller et al.	
8,122,647 B2	2/2012	Lee et al.	
D688,624 S	8/2013	Fulk et al.	
D688,625 S	8/2013	Fulk et al.	
8,905,364 B2 *	12/2014	Crary, II	H02G 7/053 248/200
8,952,251 B2	2/2015	Fulk et al.	
2010/0064598 A1	3/2010	Lee et al.	
2013/0284512 A1 *	10/2013	Fulk	H02G 7/20 174/45 R

## OTHER PUBLICATIONS

Boos, K.V. et al., Experiences Gained in the Operation of Multiple Circuit High Voltage Overhead Lines of Compact Design, CIGRE, International Conference on Large High Voltage Electric Systems, Aug. 27-Sep. 4, 1986.

Brierley, R.H. et al., Compact Right-of-Ways With Multi-Voltage Towers, IEEE Transactions on Power Delivery, Oct. 1991, pp. 1682-1689, vol. 6, No. 4.

Buckner, W.F., The Electricity Supply Industry and its Impact on Transmission Line Technology—Economical Aspects, CIGRE, 2002.

Bystrup, A Showcase of Six Shortlisted Designs, Pylon Design Competition.

Chartier, V. et al., Transmission Lines Above 700 kV, EPRI AC Transmission Line Reference Book—200kV and Above, Third Edition, Chapter 15.

Clerici, A., AC and/or DC Substantial Power Upgrading of Existing OHTL Corridors, pp. 220-225, Italy.

Barbarito, M. et al., Compact Versus Conventional EHV Lines: Technical and Economical Comparisons, CIGRE, International Conference on Large High Voltage Electric Systems, Aug. 29-Sep. 6, 1984.

Dahab, A.A. et al., Comparison of Magnetic-Field Distribution of Noncompact and Compact Parallel Transmission-Line Configurations, IEEE Transactions on Power Delivery, Jul. 2005, pp. 2114-2118, vol. 20, No. 3.

D'Ajello, L. et al., Quantitative Evaluation of the Visual Impact of Overhead Lines, CIGRE, 1996, Italy.

De La Rosa, R. et al., Contributions to Lightning Research for Transmission Line Compaction, IEEE Transactions on Power Delivery, Apr. 1988, pp. 716-723, vol. 3, No. 2.

Douglas, D. et al., Voltage Upgrading of Existing Transmission Lines, EPRI AC Transmission Line Reference Book—200 kV and Above, Third Edition, Chapter 14.

Egger, H. et al., Experience with a 380 kV "Camouflage Line", CIGRE, 1998, Austria.

Ellert, F. et al., EHV-UHV Transmission Systems, Transmission Line Reference Book 345 kV and Above, Chapter 2.

Fernandes, J.H.M. et al., 500 kV Compact Line of Eletronorte Brazil-Conception, Electrical and Mechanical Design, CIGRE, Aug. 26-Sep. 1, 1990, Brazil.

Heidari, G. et al., Effect of Land Price on Transmission Line Design, CIGRE, 2002.

Jonsson, U. et al., Optimized Reduction of the Magnetic Field Near Swedish 400 kV Lines by Advanced Control of Shield Wire Currents. Test Results and Economic Evaluation, IEEE Transactions on Power Delivery, Apr. 1994, pp. 961-969, vol. 9, No. 2.

Kimoto, I. et al, Insulator Crossarms for 345-kV EHV Transmission Line, IEEE Transactions on Power Apparatus and Systems, Mar./Apr. 1971, pp. 756-767, vol. Pas-90, No. 2.

Krylov, S.V., Design, Mechanical Aspects and Other Subjects of Compact EHV OHL Technology, Midwest ISO-Expanding Edge Seminar, St. Paul, MN, Sep. 16, 2004.

Liao, Y. et al., Included Angle Selection of V-Shape Insulator Strong for 750-kV Compact Transmission Line, IEEE Transactions on Power Delivery, Jan. 2011, pp. 385-393, vol. 26, No. 1.

Liu, L. et al., Experimental Flashover Research on Switching Impulse of 750 kV Single Circuite Compact Transmission Line Tower, CIGRE, 2010.

Loudon, D. et al., A Compact 420 kV Line Utilising Line Surge Arresters for Areas With Low Isokeraunic Levels, CIGRE, 1998.

Melo, Miguel et al., Electric and Magnetic Fields of Compact Transmission Lines, IEEE Transactions on Power Delivery, Jan. 1999, pp. 200-204, vol. 14, No. 1.

Mousa, A., The Electric Fields at Ground Level Associated with the Inverted Delta Configuration, IEEE Transactions on Power Apparatus and Systems, Dec. 12, 1981, pp. 4913-4917, vol. Pas-100, No. 12.

Ordon, Thomas et al., Considerations in the Design of Three Phase Compact Transmission Lines, pp. 108-114, 1994.

Regis, O. Jr. et al., Expanded Bundle Technique: The Application of HSIL TL Concept to Increase the Capacity of overhead Lines, CIGRE, 1998.

Stoffel, J.B. et al., Electric Power High-Voltage Transmission Lines: Design Options, Cost, and Electric and Magnetic Field Levels, Argonne National Laboratory, Nov. 1994.

Villa, Paolo et al., Compact Transmission Line with Inverted Delta Configuration, CIGRE, 2002, Italy.

Zobel, E.S. et al., Narrower Transmission Corridors Made Possible with New Compacted Conductor Support Systems for EHV and UHV Lines, CIGRE, International Conference on Large High Voltage Electric Systems, Aug. 27-Sep. 4, 1980.

AEP, Sorenson, Robinson Park, Nov. 2014-Mar. 2015.

\* cited by examiner



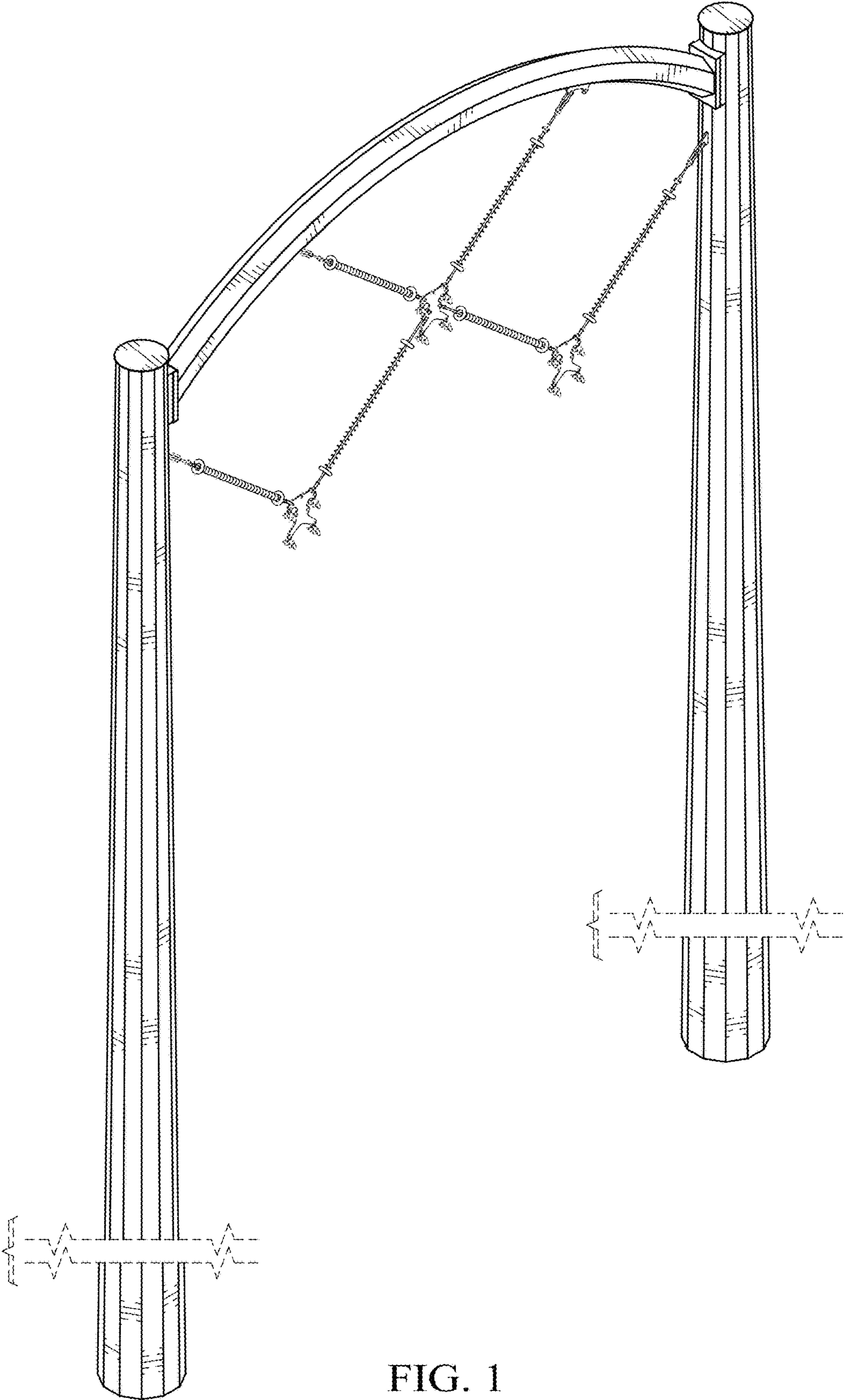

FIG. 1

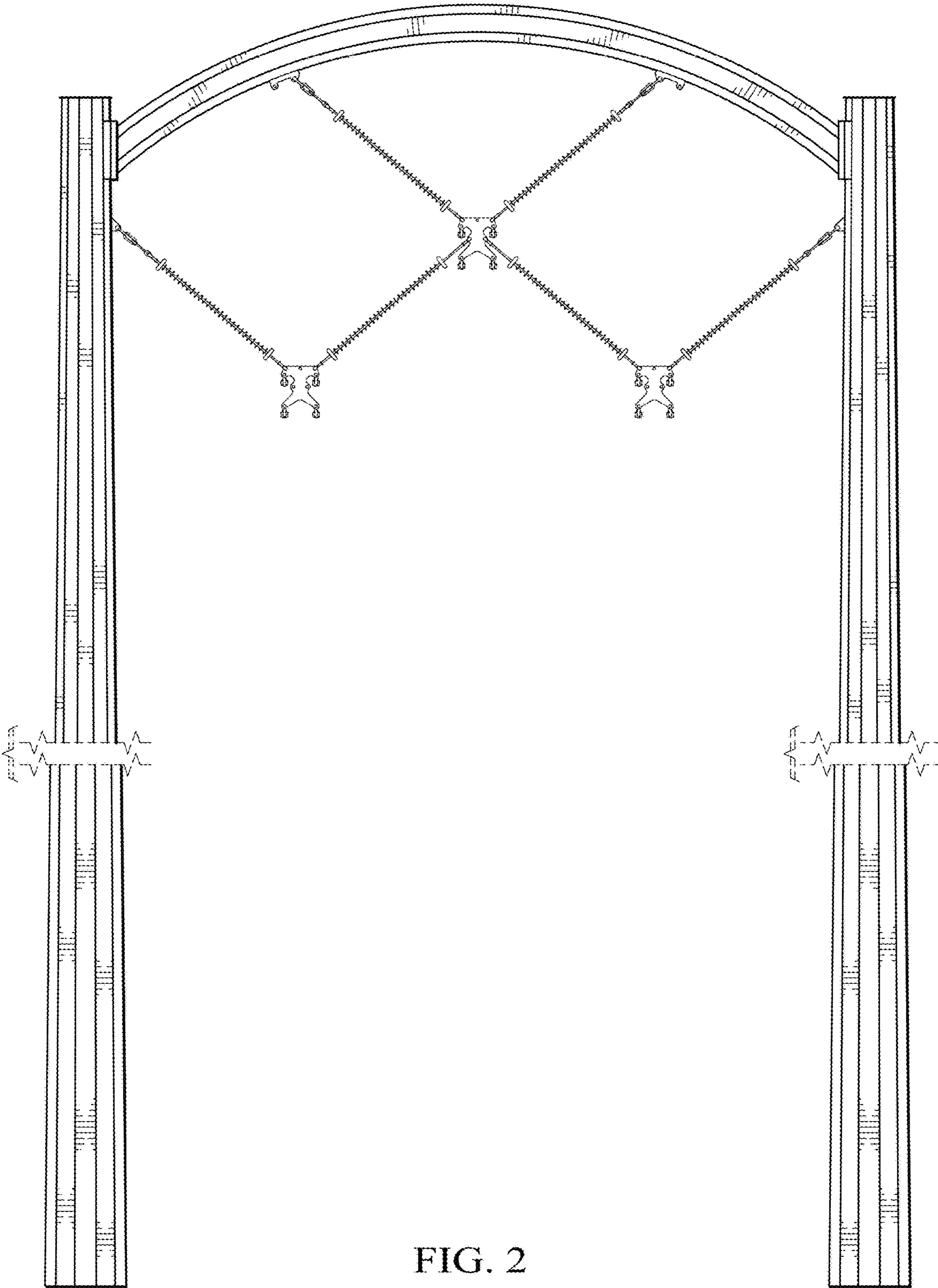

FIG. 2

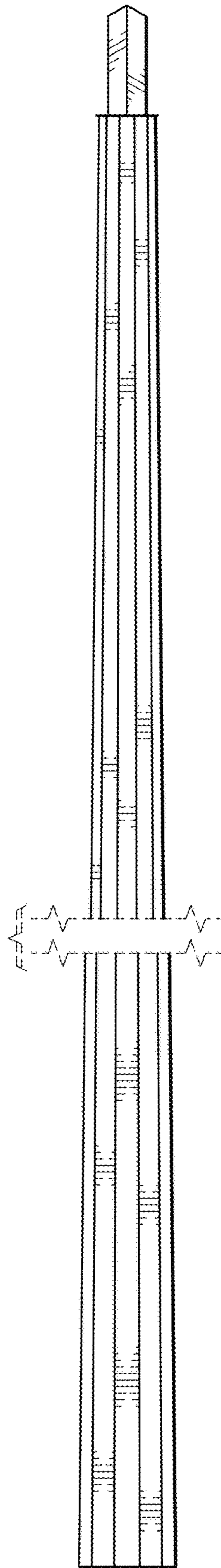

FIG. 3

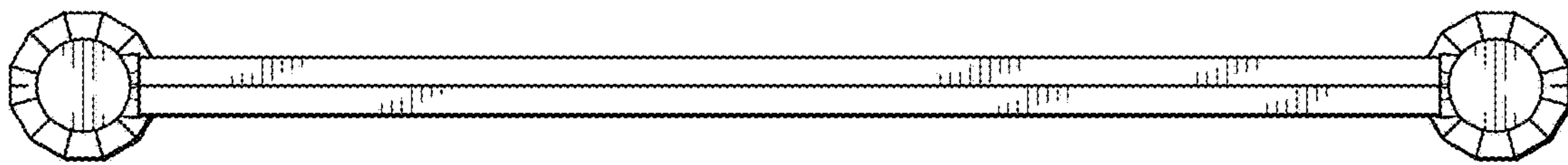

FIG. 4

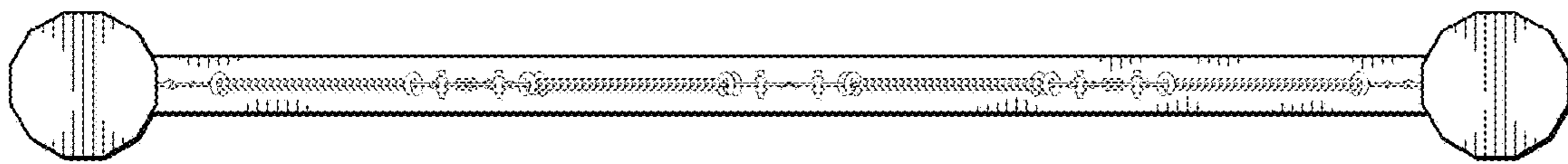

FIG. 5