



US00D853569S

(12) **United States Design Patent** (10) **Patent No.:** **US D853,569 S**
Seki (45) **Date of Patent:** **** Jul. 9, 2019**

(54) **BIOSIGNAL DETECTOR**

(71) Applicant: **MELTIN MMI CO., LTD.**, Tokyo (JP)

(72) Inventor: **Tatsuya Seki**, Tokyo (JP)

(73) Assignee: **MELTIN MMI CO., LTD.**, Tokyo (JP)

(**) Term: **15 Years**

(21) Appl. No.: **35/504,324**

(22) Filed: **Jul. 14, 2017**

(80) **Hague Agreement Data**

Int. Filing Date: **Jul. 14, 2017**

Int. Reg. No.: **DM/098348**

Int. Reg. Date: **Jul. 14, 2017**

Int. Reg. Pub. Date: **Jan. 19, 2018**

(30) **Foreign Application Priority Data**

Jan. 16, 2017 (JP) 2017-575

Jan. 16, 2017 (JP) 2017-576

(Continued)

(51) **LOC (11) Cl.** **24-02**

(52) **U.S. Cl.**
USPC **D24/186**

(58) **Field of Classification Search**
USPC D24/186, 187, 200; D14/205
(Continued)

(56) **References Cited**

U.S. PATENT DOCUMENTS

D578,221 S * 10/2008 Sakurai D24/187

D578,222 S * 10/2008 Sakurai D24/187

(Continued)

Primary Examiner — Eliza Z Bennett-Hattan

(74) *Attorney, Agent, or Firm* — Renner, Otto, Boisselle & Sklar, LLP

(57) **CLAIM**

The ornamental design for a biosignal detector, as shown and described.

DESCRIPTION

1.-2. Biosignal detectors

1.1 : Perspective

1.2 : Perspective

1.3 : Front

1.4 : Back

1.5 : Right

1.6 : Left

1.7: Top

1.8: Bottom

1.9: Partial enlarged view of 1.1

1.10 : Partial enlarged view of 1.2

1.11 : Reference view—electrodes

1.12 : Reference view—electrodes

1.13 : Reference view of state in use

2.1 : Perspective

2.2 : Perspective

2.3 : Front

2.4 : Back

2.5 : Right

2.6 : Left

2.7 : Top

2.8 : Bottom

2.9 : Partial enlarged view of 2.1

2.10 : Partial enlarged view of 2.2

2.11 : Reference view—electrodes

2.12 : Reference view—electrodes

2.13 : Reference view of state in use

The solid lines form part of the claimed designs; the broken lines depict unclaimed portions of the biosignal detector and form no part of the claim, additionally, the broken lines forming the outer edges of a wearer in Figs. 1.13 & 2.13 depict environmental subject matter only and form no part of the claimed design; the biosignal detectors of designs 1 and 2 can detect biosignals (e.g., electrocardio signals, mastication signals) using the electrodes.

1 Claim, 26 Drawing Sheets

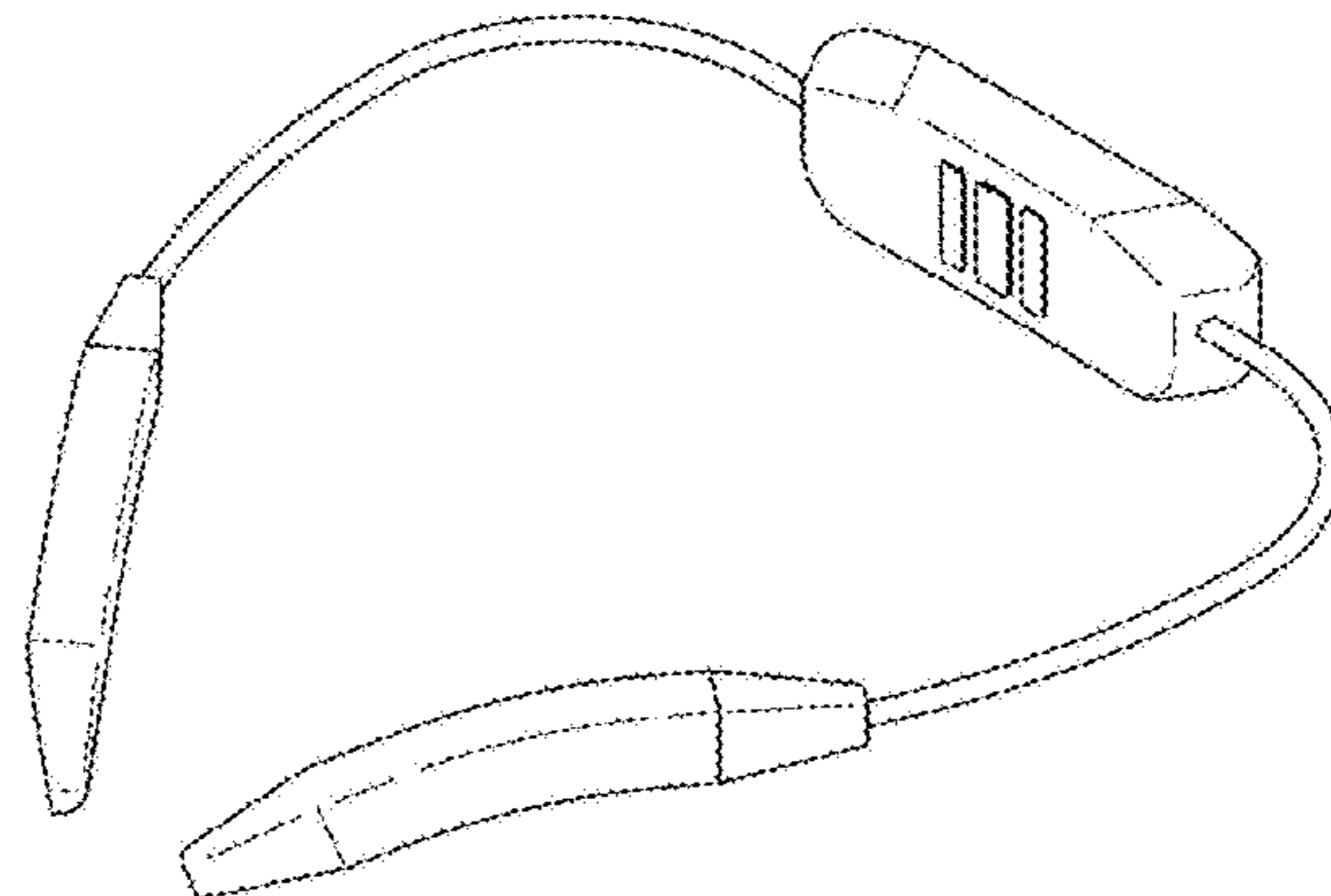

(30) Foreign Application Priority Data

Jan. 16, 2017 (JP) 2017-577
 Jan. 16, 2017 (JP) 2017-578
 Jan. 16, 2017 (JP) 2017-579
 Jan. 16, 2017 (JP) 2017-580
 Jan. 16, 2017 (JP) 2017-581
 Jan. 16, 2017 (JP) 2017-582
 Jan. 16, 2017 (JP) 2017-583
 Jan. 16, 2017 (JP) 2017-584
 Jan. 16, 2017 (JP) 2017-585
 Jan. 16, 2017 (JP) 2017-586
 Jan. 16, 2017 (JP) 2017-587

(58) Field of Classification Search

CPC A61B 5/0478
 See application file for complete search history.

(56) References Cited

U.S. PATENT DOCUMENTS

D585,557 S * 1/2009 Sakurai D24/187
 D721,673 S * 1/2015 Park D14/205

D743,933 S * 11/2015 Park D14/205
 9,232,366 B1 * 1/2016 Charlier H04R 1/1041
 D750,794 S * 3/2016 Guarraia D24/200
 D751,214 S * 3/2016 Guarraia D24/200
 D751,722 S * 3/2016 Guarraia D24/200
 D752,236 S * 3/2016 Guarraia D24/200
 D752,766 S * 3/2016 Guarraia D24/200
 D753,316 S * 4/2016 Guarraia D24/200
 D756,959 S * 5/2016 Lee D14/205
 D768,024 S * 10/2016 Dayal D10/65
 D795,110 S * 8/2017 Takizawa D10/106.1
 D796,051 S * 8/2017 Ruffini D24/187
 D796,683 S * 9/2017 Smeros D24/187
 D797,296 S * 9/2017 Dehollander D24/187
 D800,089 S * 10/2017 Park D14/205
 9,981,127 B2 * 5/2018 Guarraia A61N 1/36
 D827,143 S * 8/2018 Dayal D24/187
 D832,812 S * 11/2018 Fyrlund D14/205
 2013/0274583 A1 * 10/2013 Heck A61B 5/0488
 600/383
 2015/0196101 A1 * 7/2015 Dayal A61H 3/061
 63/1.11
 2016/0098138 A1 * 4/2016 Park G06F 3/0416
 345/173

* cited by examiner

1.1

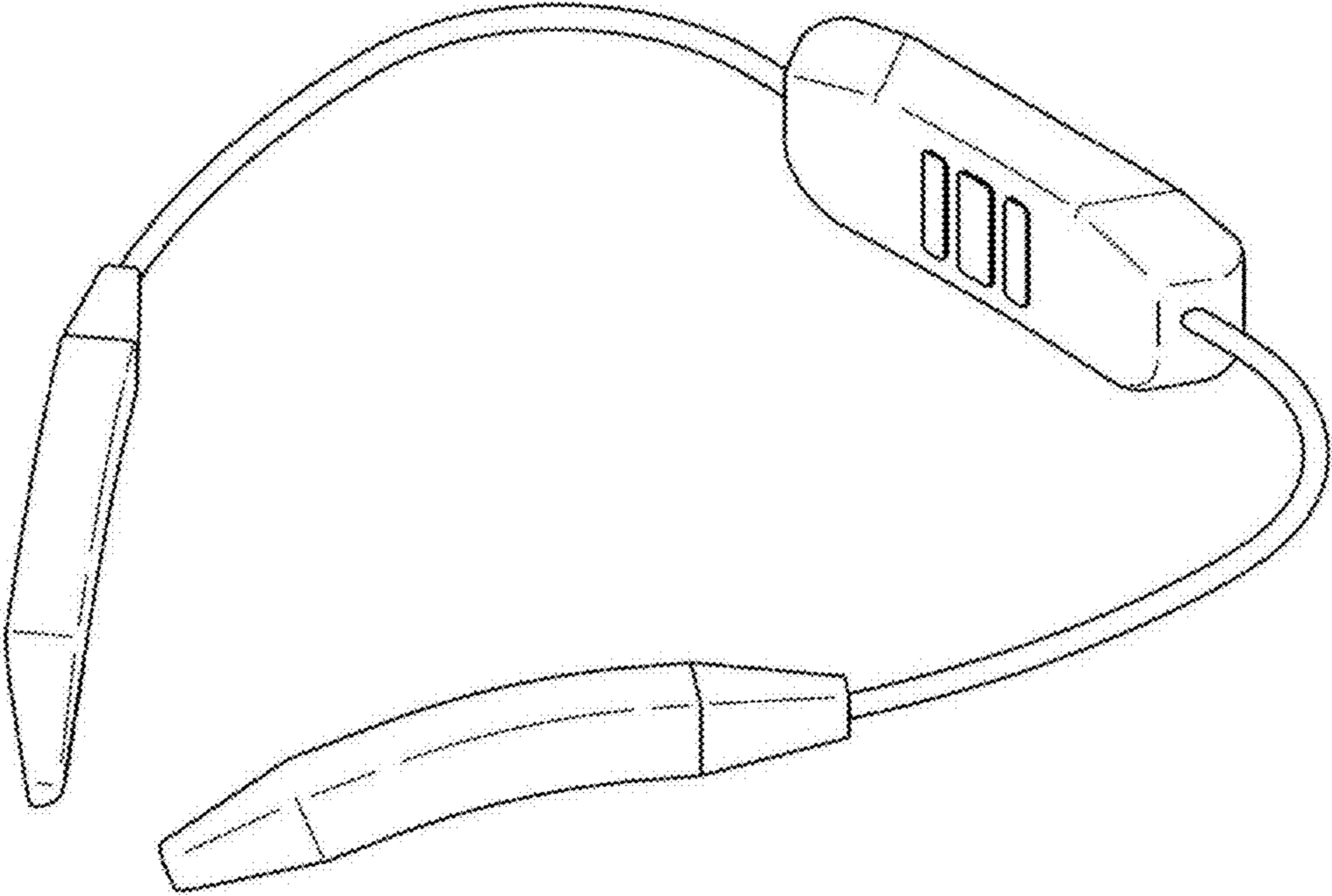

1.2

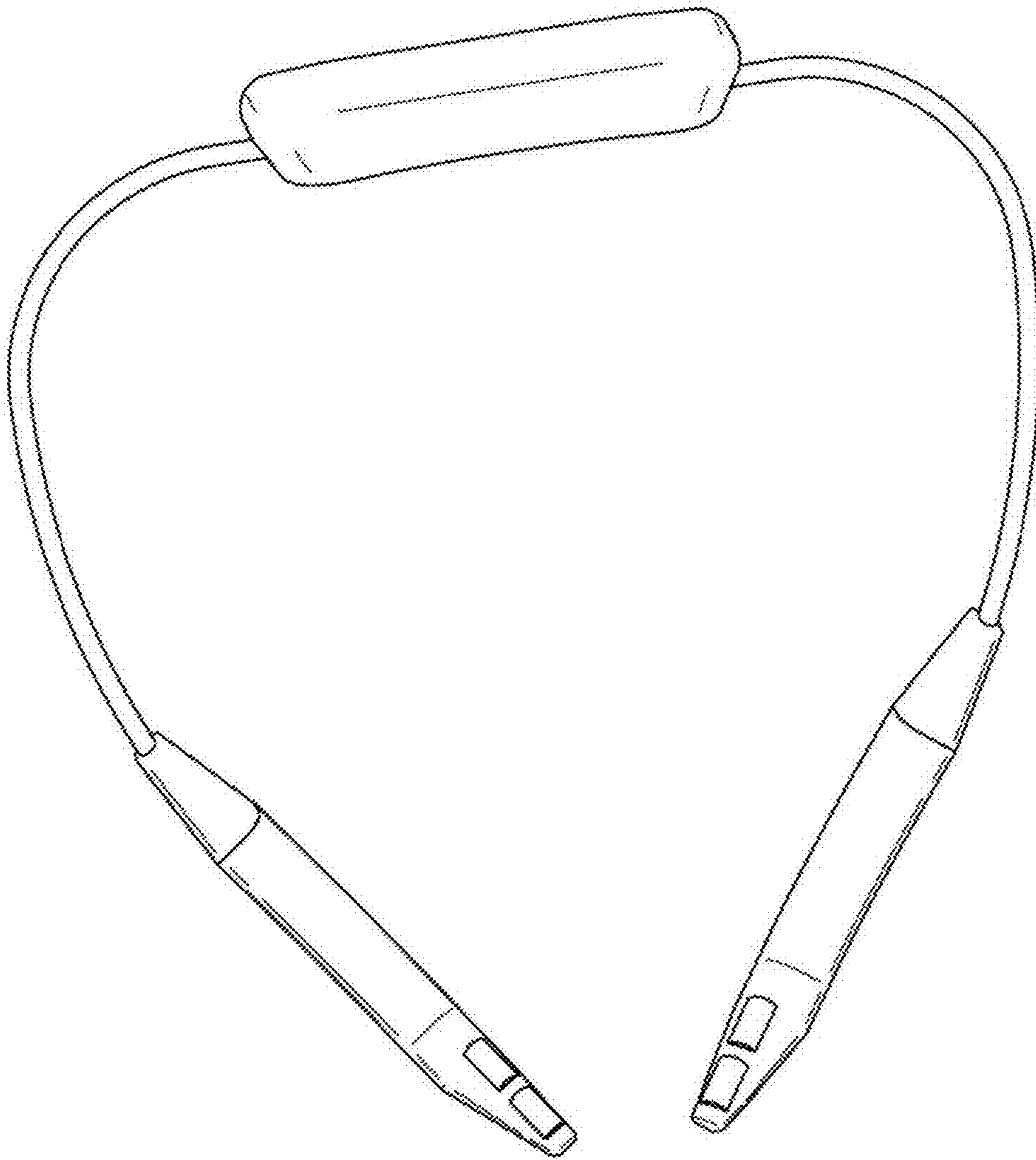

1.3

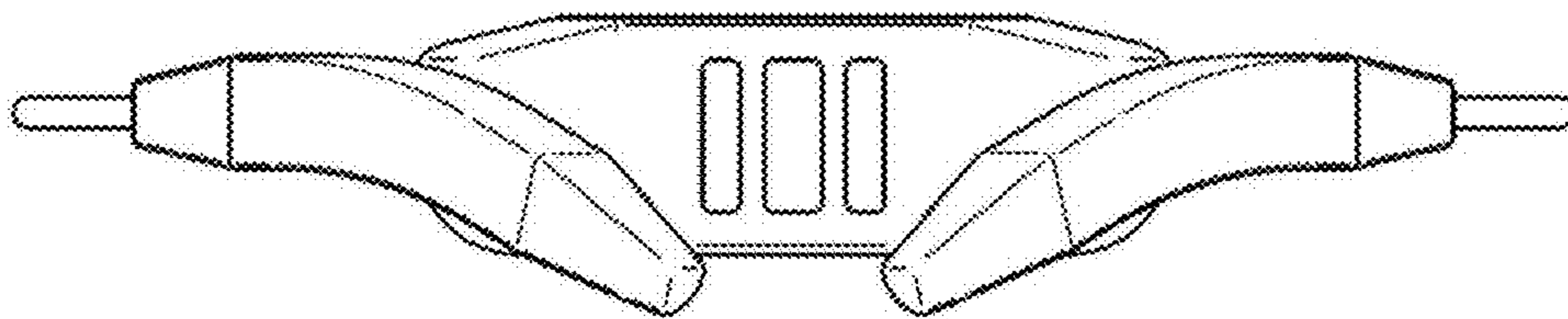

1.4

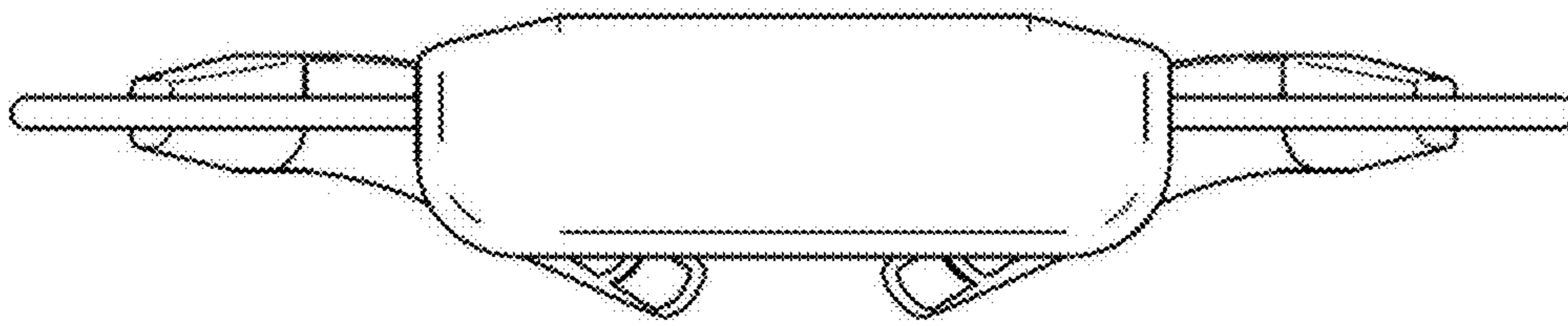

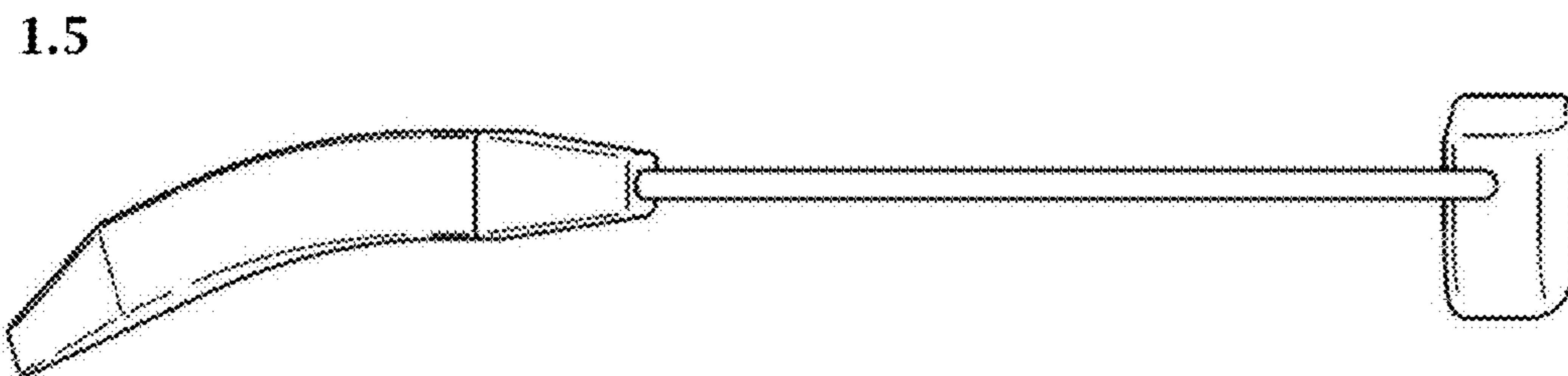

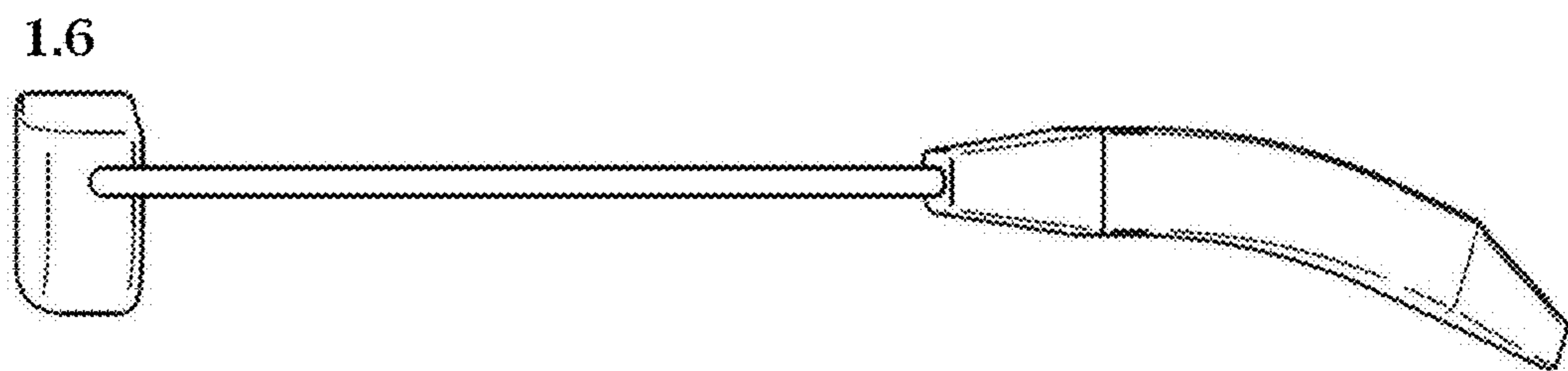

1.7

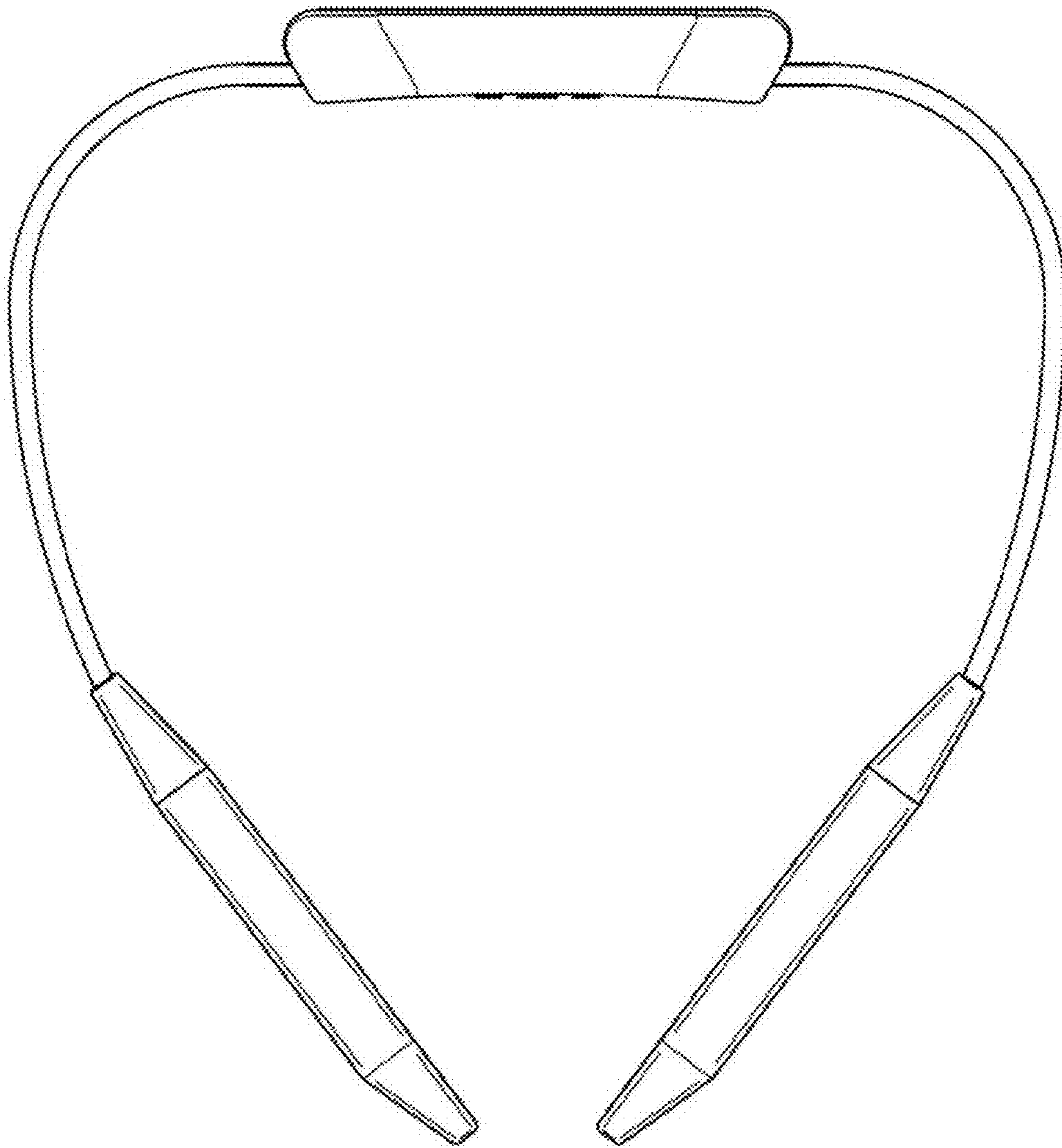

1.8

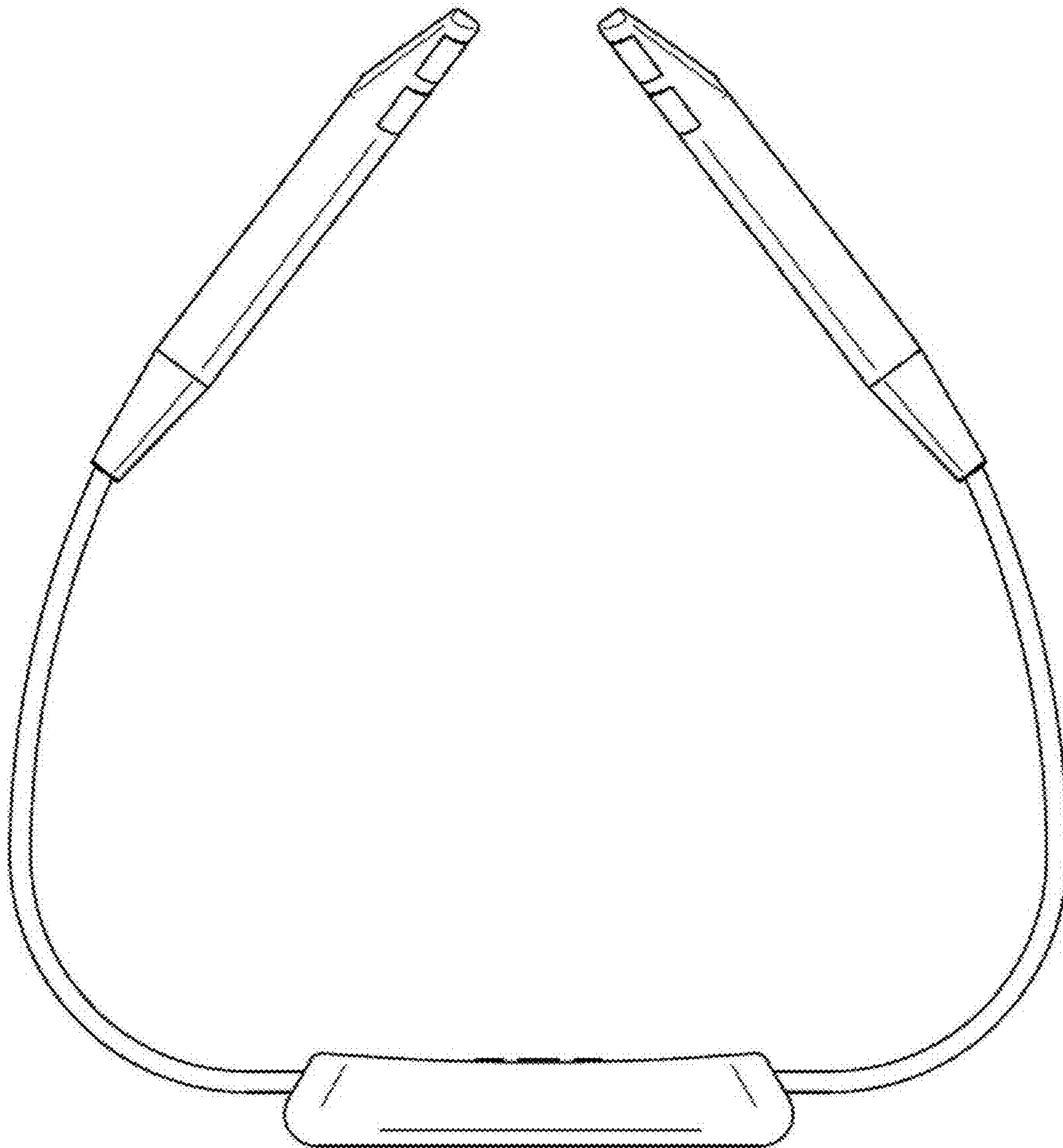

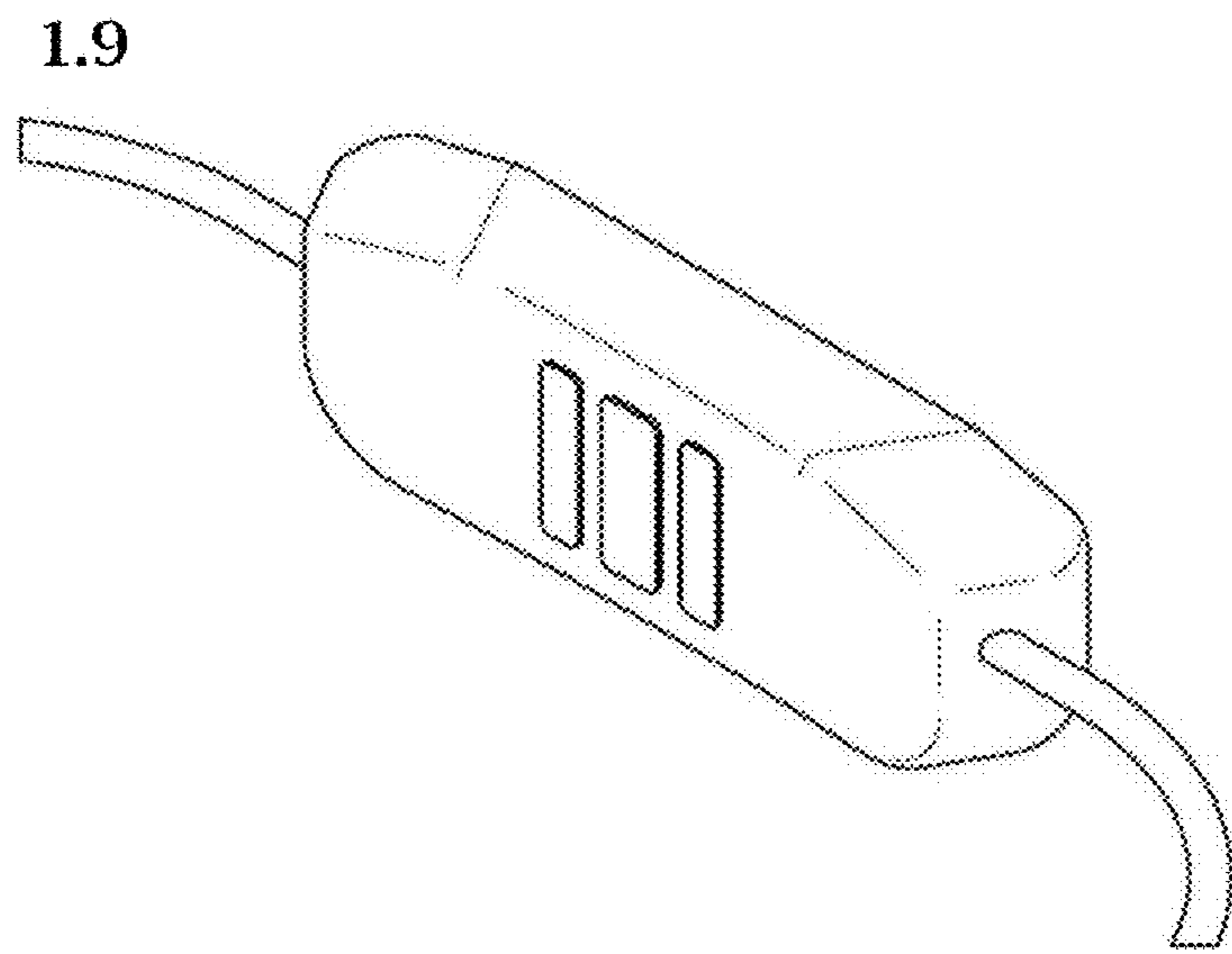

1.10

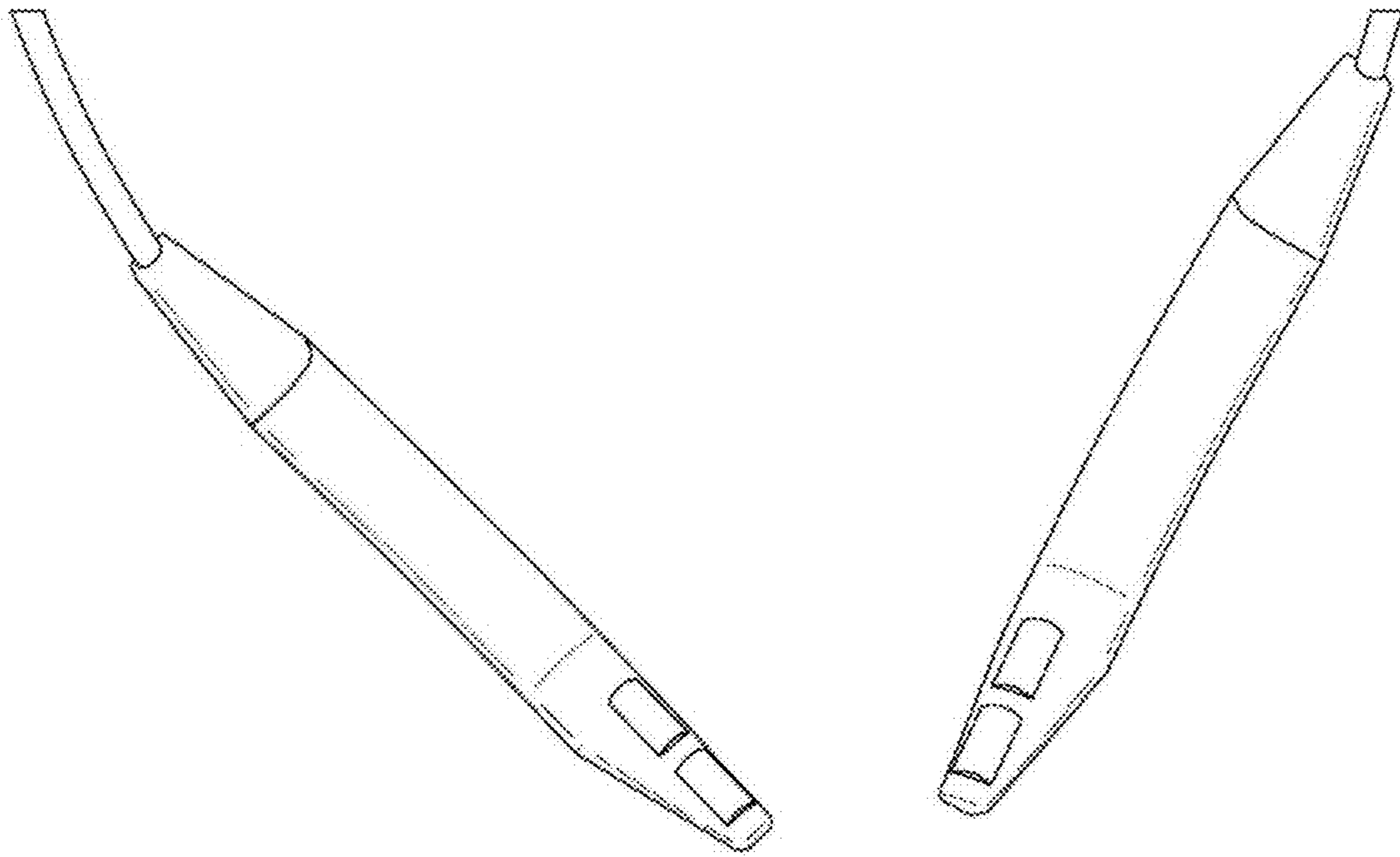

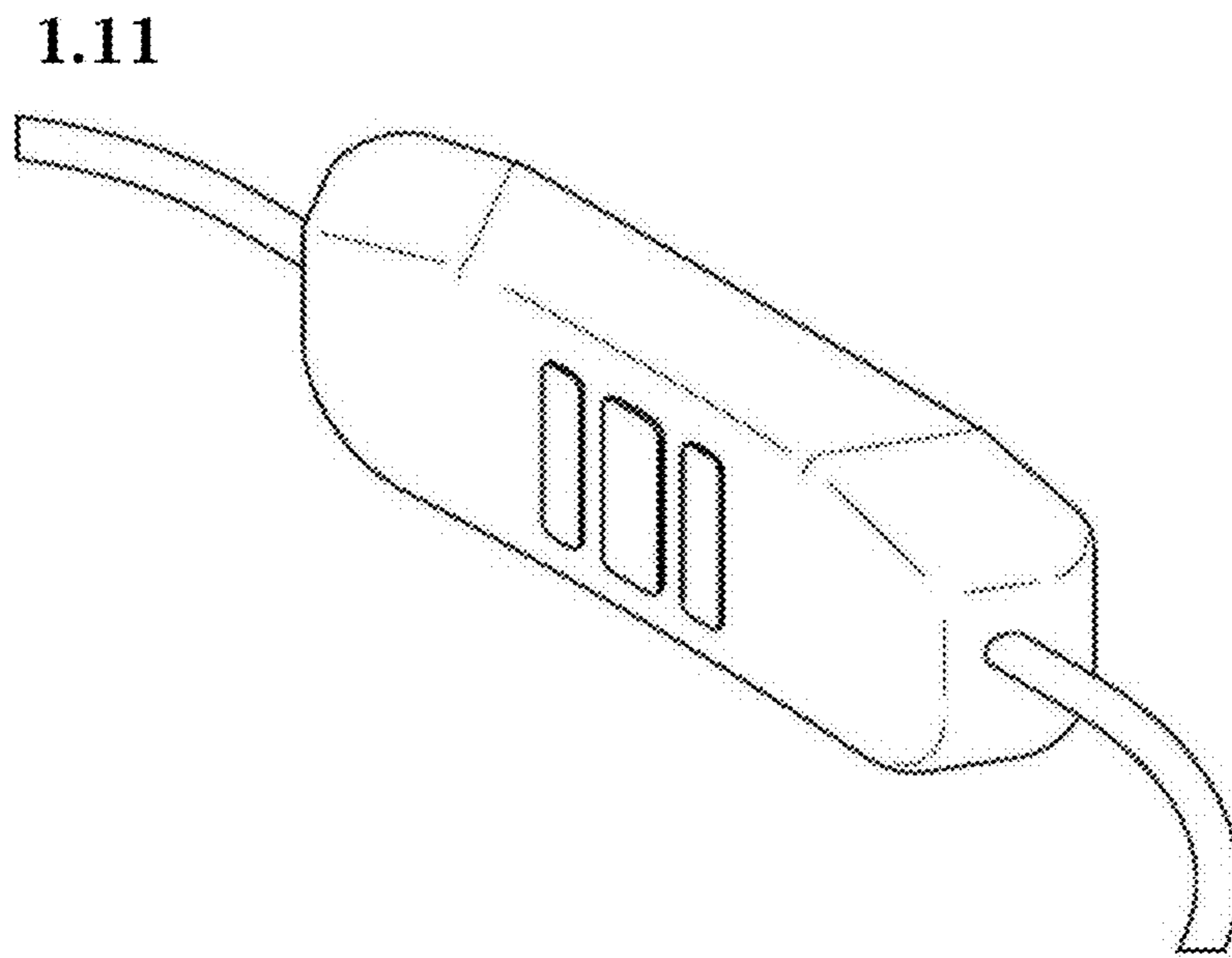

1.12

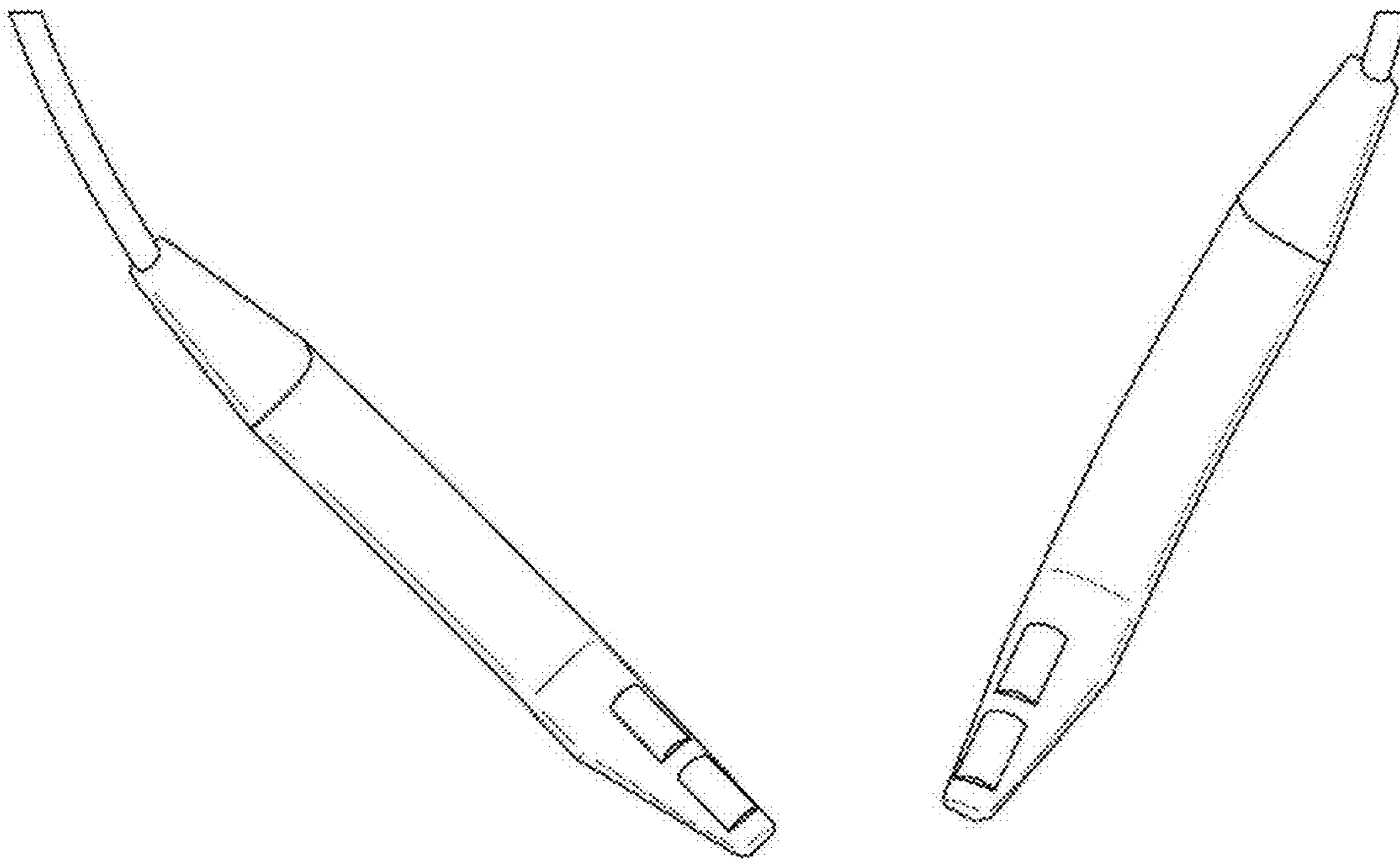

1.13

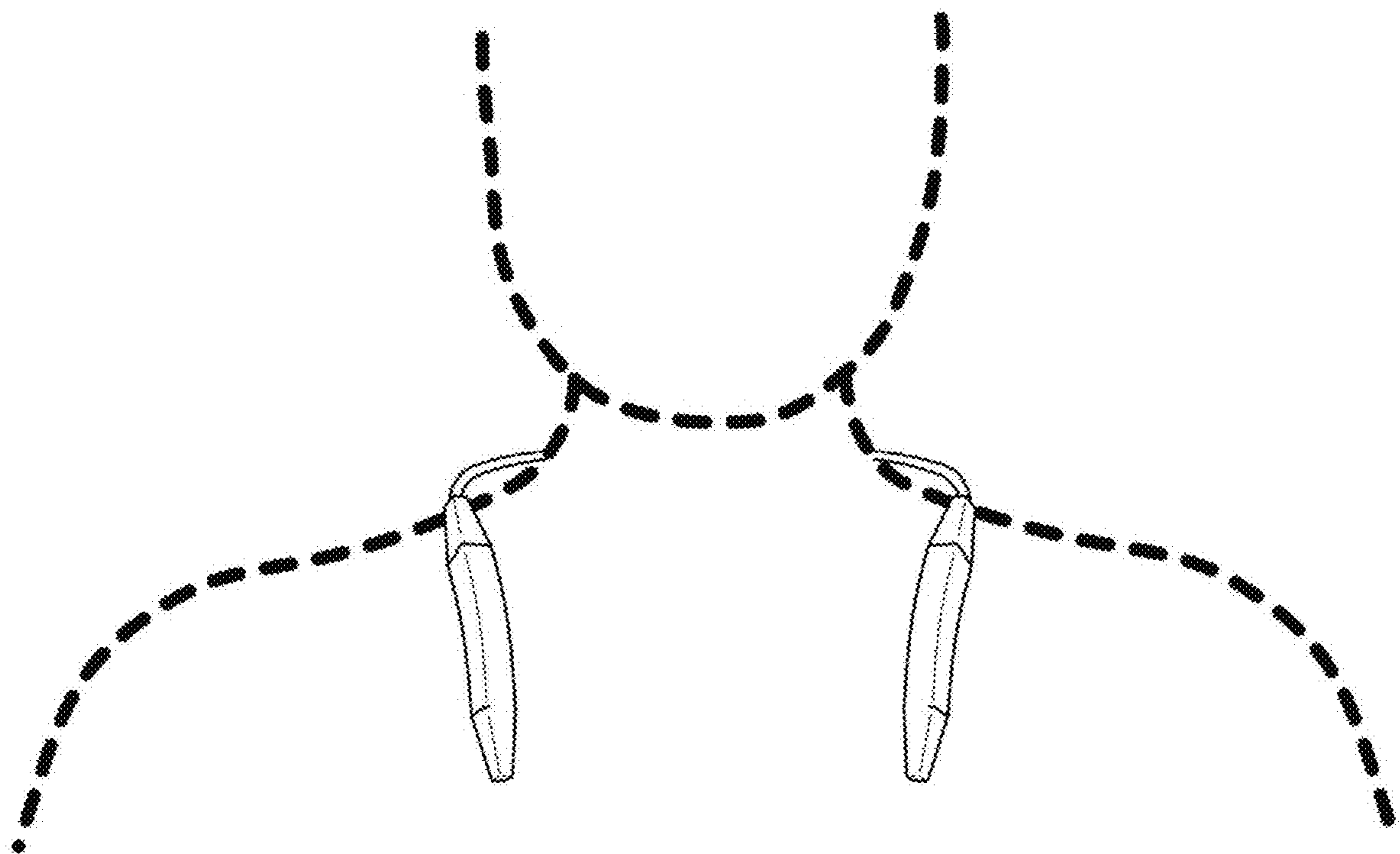

2.1

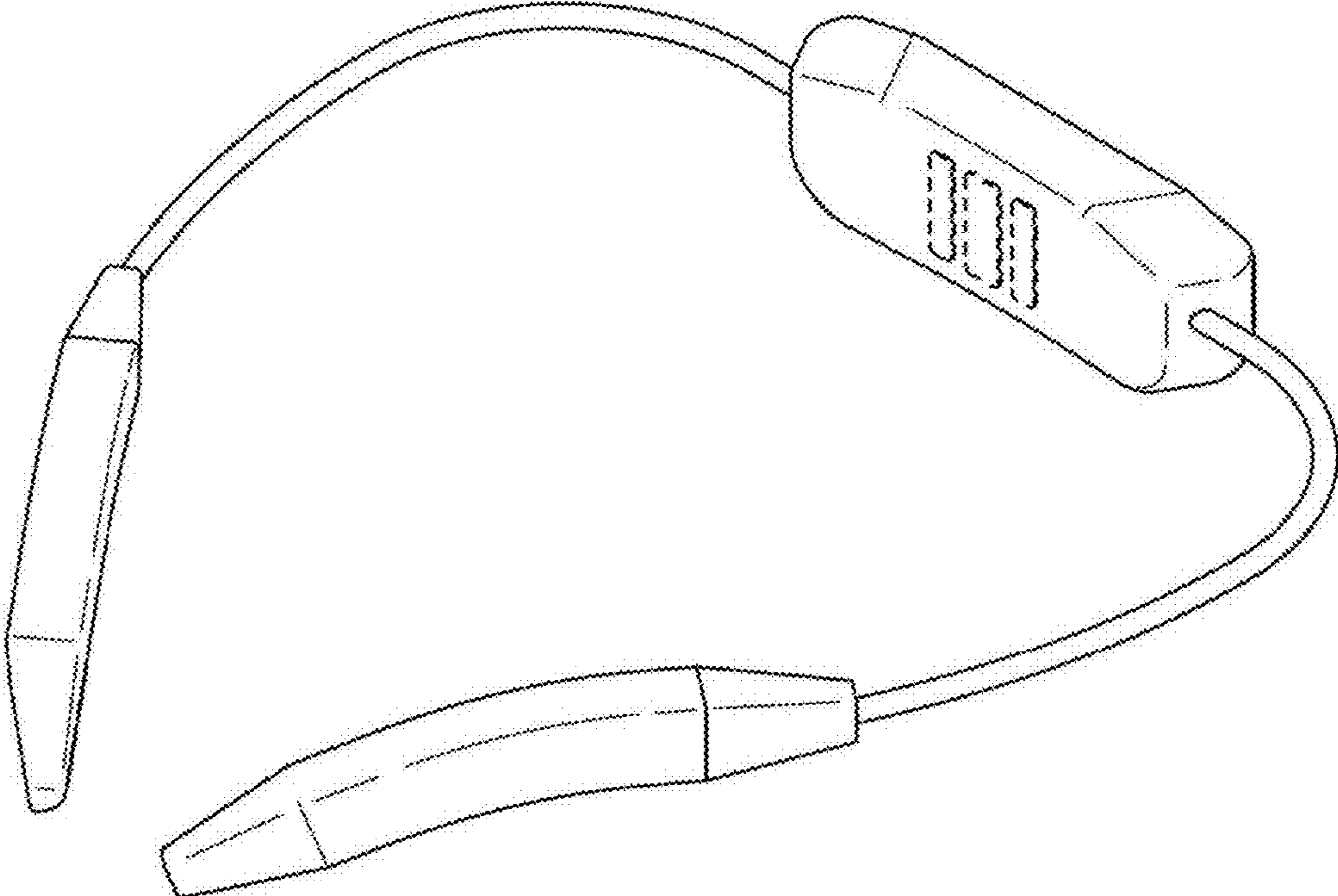

2.2

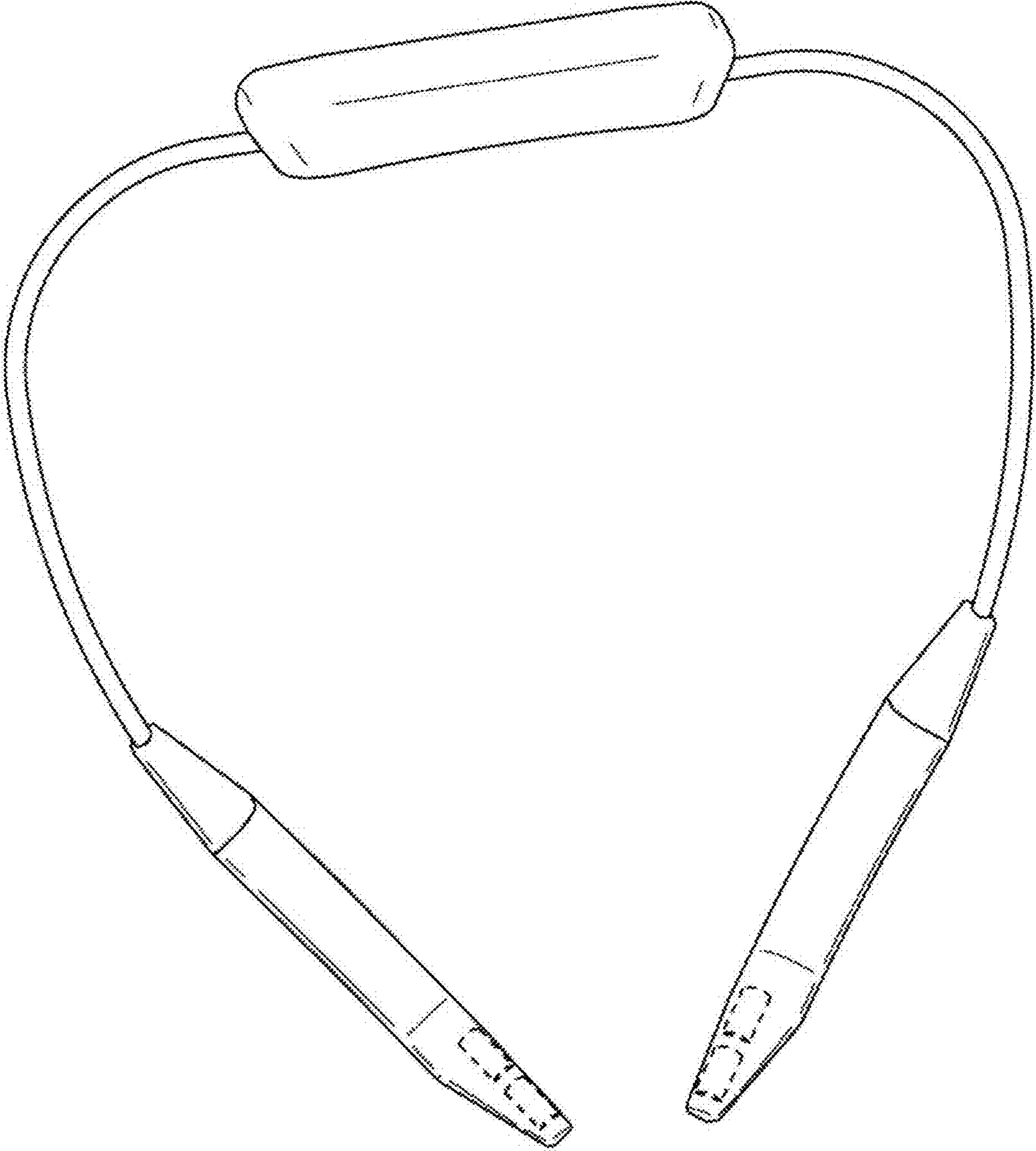

2.3

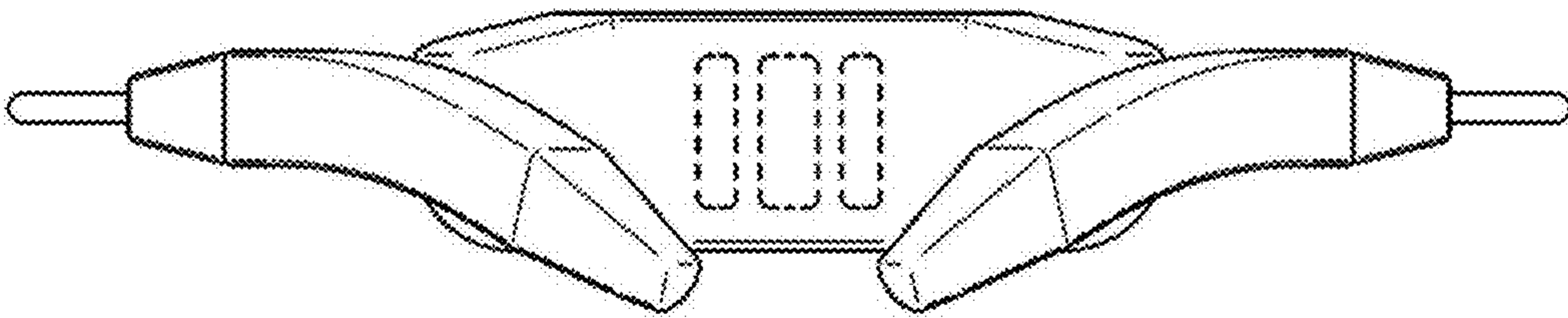

2.4

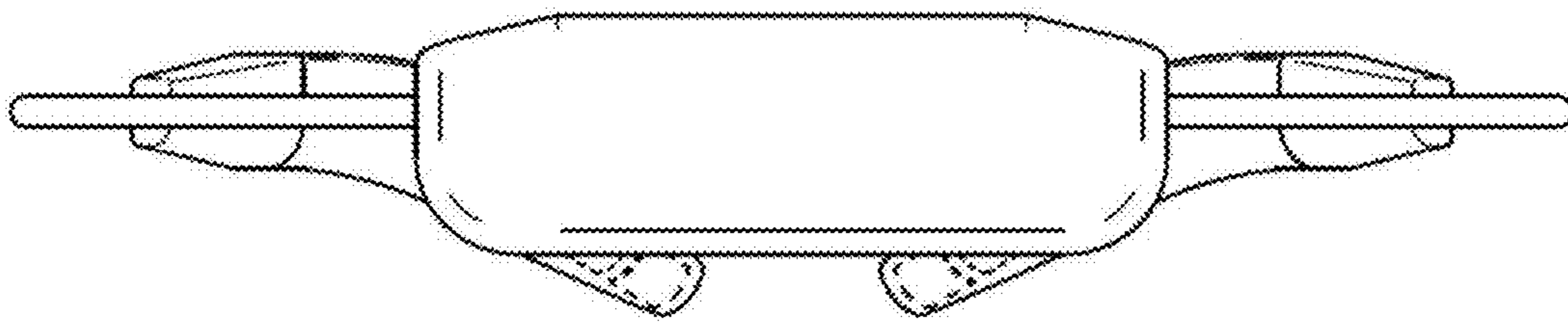

2.5

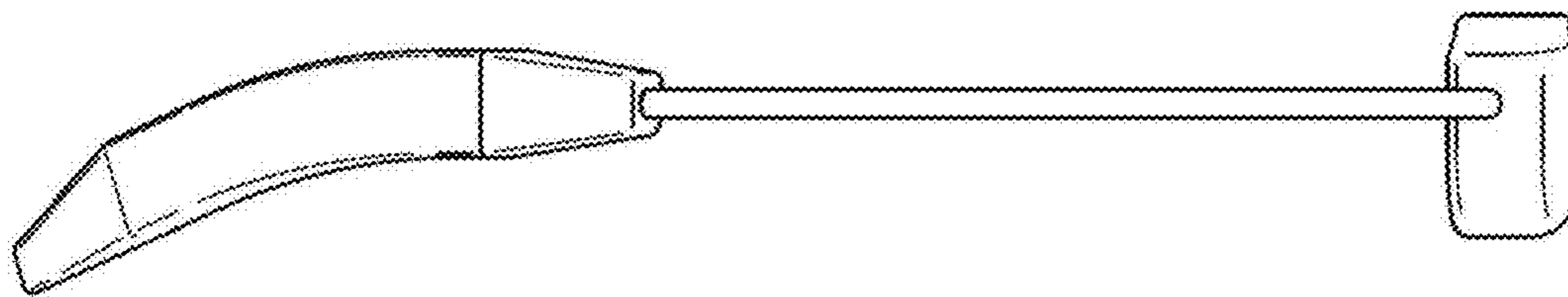

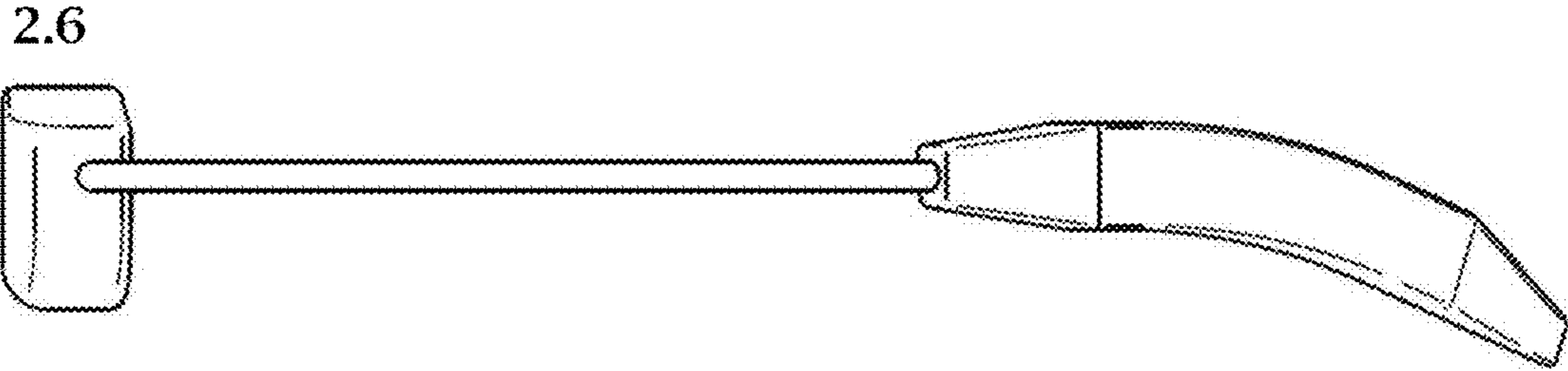

2.7

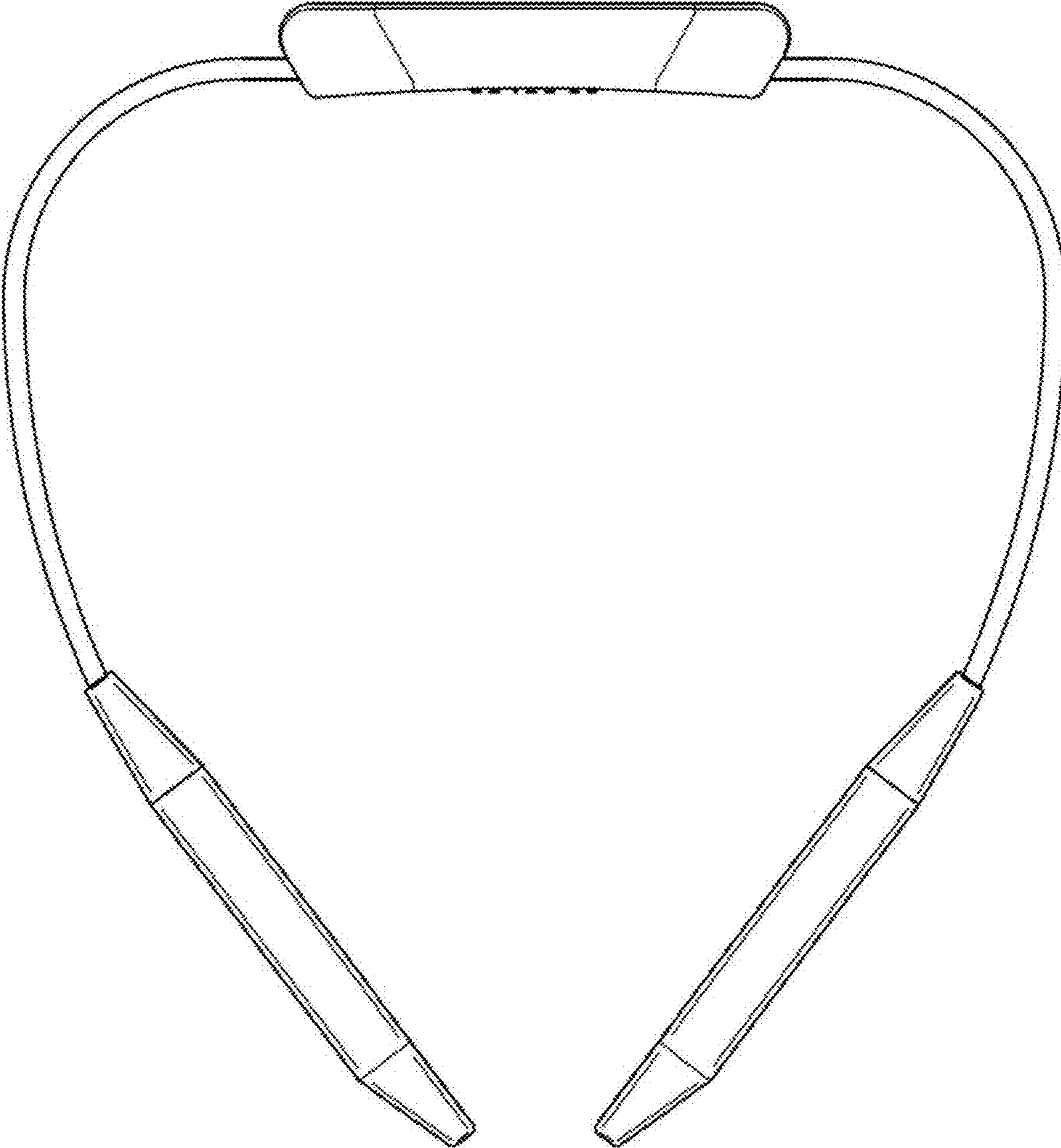

2.8

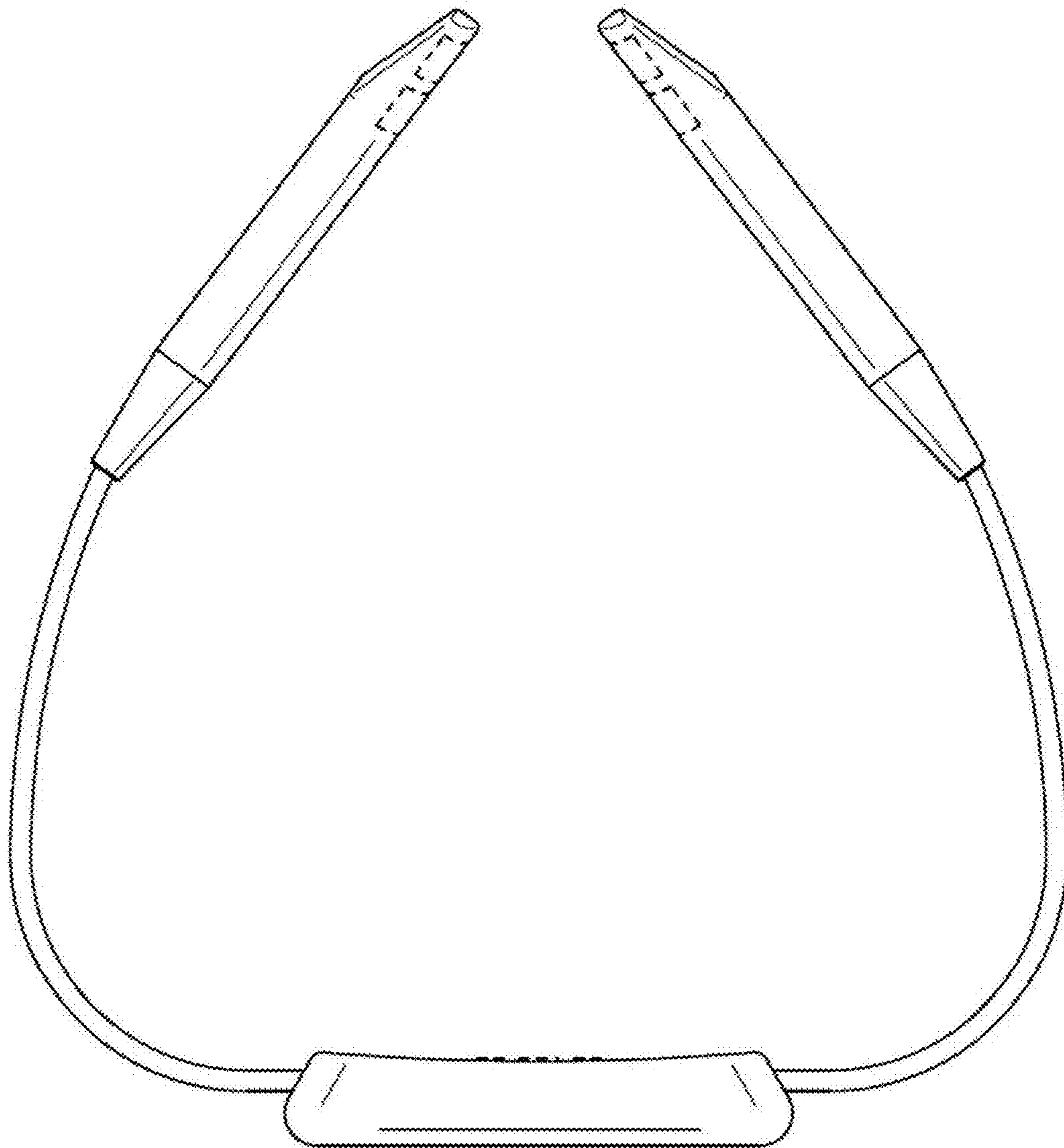

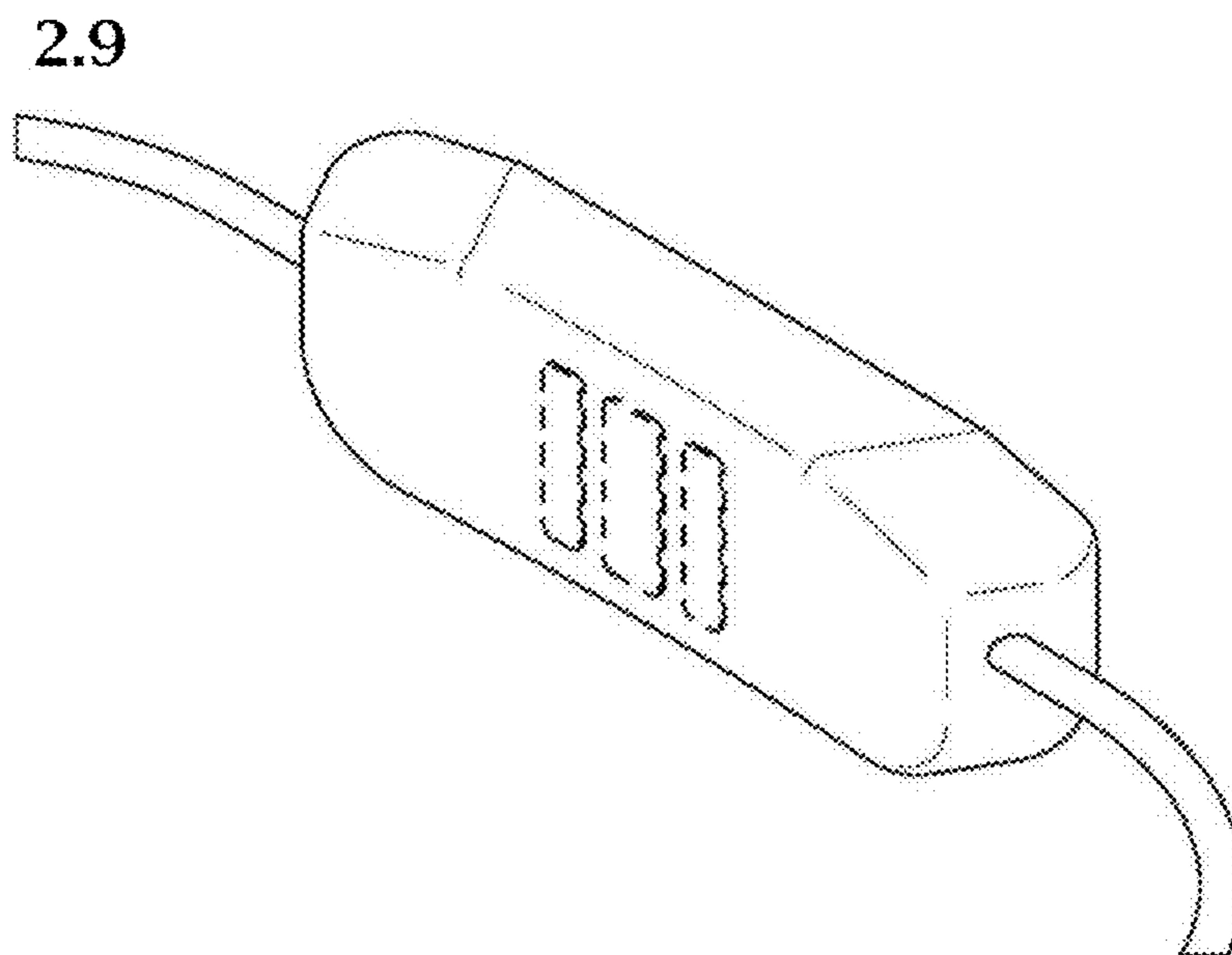

2.10

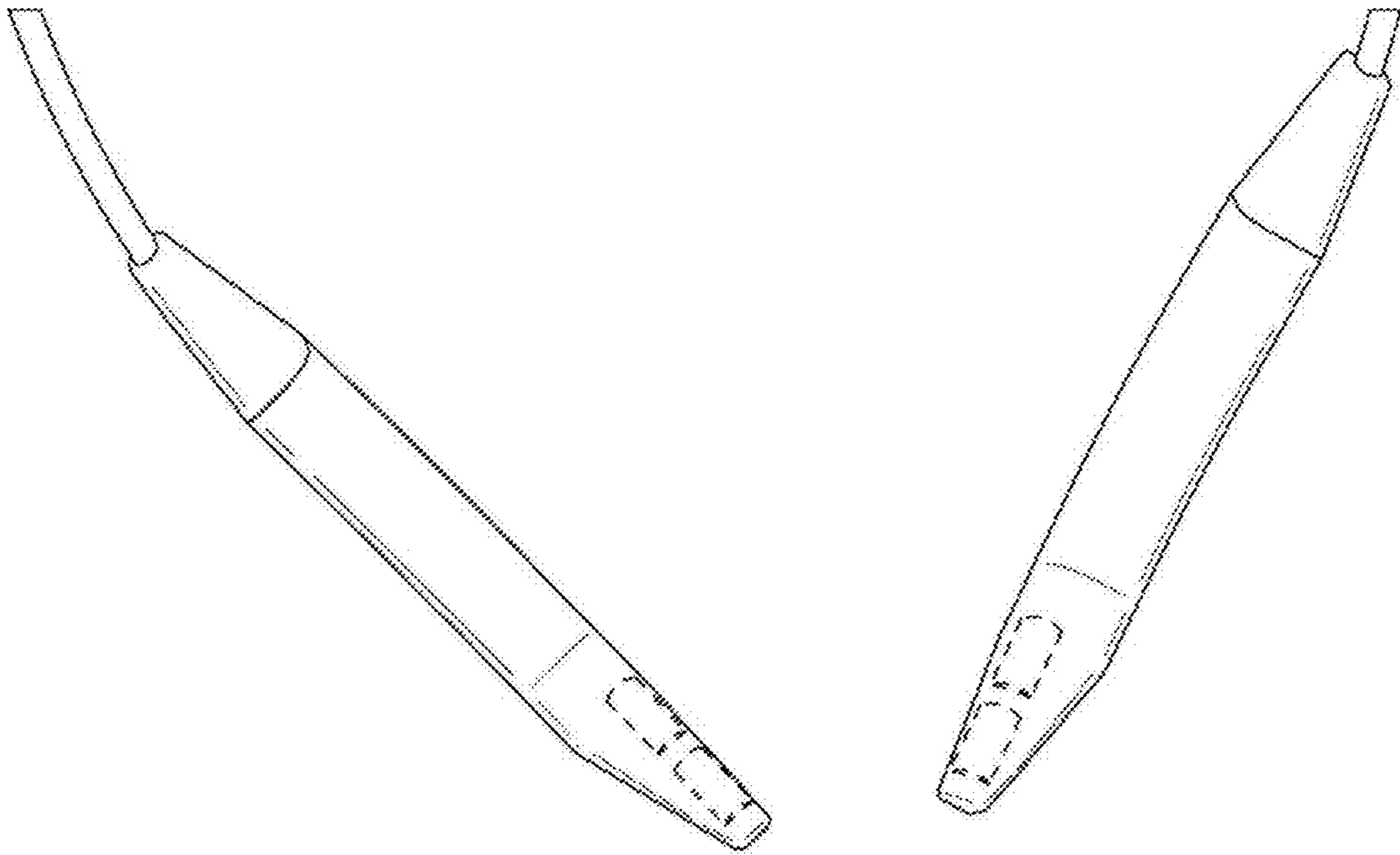

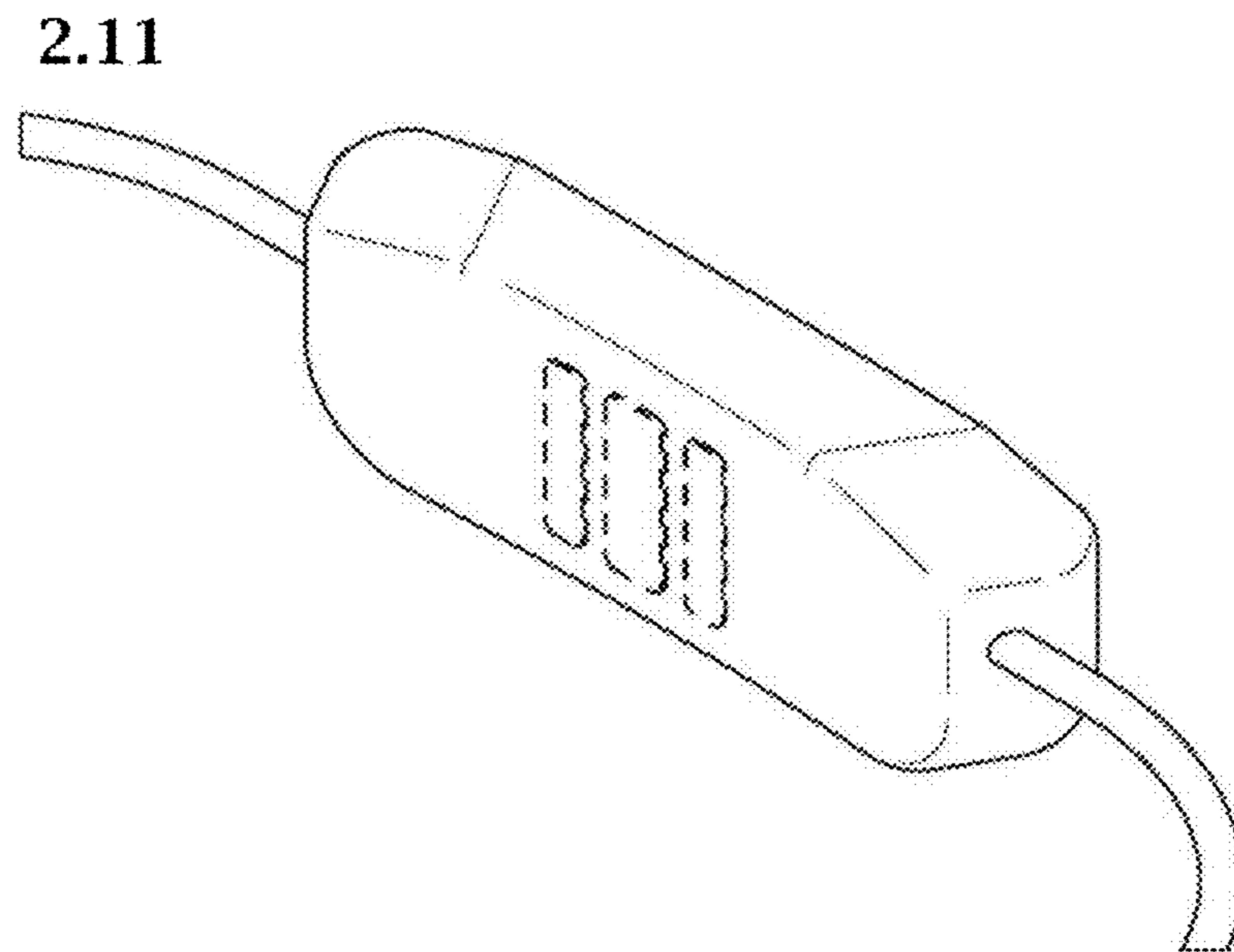

2.12

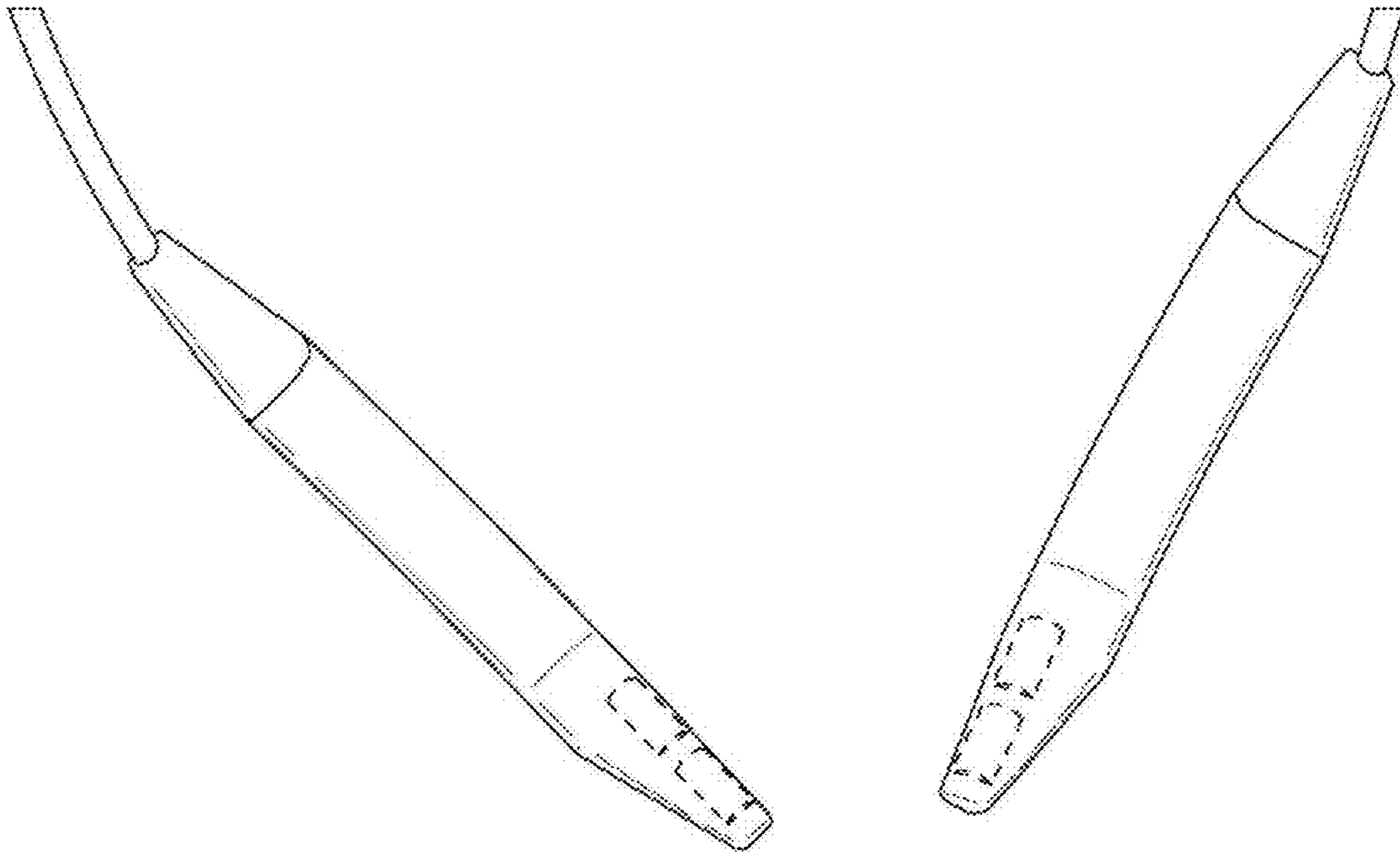

2.13

