



US00D852986S

(12) **United States Design Patent**
Popovich

(10) **Patent No.:** **US D852,986 S**
(45) **Date of Patent:** **** Jul. 2, 2019**

(54) **SELF-ADJUSTING BRIDGING FOR FLOORBOARD JOISTS**

(71) Applicant: **Steve Popovich**, Beecher, IL (US)
(72) Inventor: **Steve Popovich**, Beecher, IL (US)
(**) Term: **15 Years**

(21) Appl. No.: **29/657,268**

(22) Filed: **Jul. 20, 2018**

(51) **LOC (11) Cl.** **25-01**

(52) **U.S. Cl.**
USPC **D25/133**

(58) **Field of Classification Search**
USPC D25/126, 127, 128, 129, 130, 131, 132,
D25/133, 134, 135, 102, 110, 119, 124,
(Continued)

(56) **References Cited**

U.S. PATENT DOCUMENTS

457,664 A 8/1891 Paine
459,900 A * 9/1891 Gustafson E04C 3/02
52/695

(Continued)

OTHER PUBLICATIONS

“Speed Pro 400cm Centre Herringbone Joist Struts” <http://www.builderdepot.co.uk/pound-0-35-per-strutt-box-of-50no-speed-pro-400mm-centre-herringbone-joist-struts-480mm-long-galvanised.html> Apr. 28, 2018 (Year: 2018).*

(Continued)

Primary Examiner — Cathron C Brooks
Assistant Examiner — Samantha Q Lawrence
(74) *Attorney, Agent, or Firm* — Lesley A. Wallerstein, LLC

(57) **CLAIM**

The ornamental design for a self-adjusting bridging for floorboard joists, as shown and described.

DESCRIPTION

FIG. 1 is a top perspective front view of a self-adjusting bridging for floorboard joists, according to the present invention.

FIG. 2 is a top perspective view of the self-adjusting bridging for floorboard joists of FIG. 1.

FIG. 3 is a bottom perspective view of the self-adjusting bridging for floorboard joists of FIG. 1.

FIG. 4 is a partial enlarged view of FIG. 2 of the self-adjusting bridging for floorboard joists.

FIG. 5 is a front view of the self-adjusting bridging for floorboard joists of FIG. 1, shown in an open position.

FIG. 6 is a back view of the self-adjusting bridging for floorboard joists of FIG. 1, shown in an open position.

FIG. 7 is a left view of the self-adjusting bridging for floorboard joists of FIG. 1, shown in an open position.

FIG. 8 is a right view of the self-adjusting bridging for floorboard joists of FIG. 1, shown in an open position.

FIG. 9 is a top view of the self-adjusting bridging for floorboard joists of FIG. 1, shown in an open position.

FIG. 10 is a bottom view of the self-adjusting bridging for floorboard joists of FIG. 1, shown in an open position.

FIG. 11 is a front view of the self-adjusting bridging for floorboard joists of FIG. 1, shown in a closed position.

FIG. 12 is a back view of the self-adjusting bridging for floorboard joists of FIG. 1, shown in a closed position.

FIG. 13 is a left view of the self-adjusting bridging for floorboard joists of FIG. 1, shown in a closed position.

FIG. 14 is a right view of the self-adjusting bridging for floorboard joists of FIG. 1, shown in a closed position.

FIG. 15 is a top view of the self-adjusting bridging for floorboard joists of FIG. 1, shown in a closed position; and,

FIG. 16 is a bottom view of the self-adjusting bridging for floorboard joists of FIG. 1, shown in a closed position.

The broken lines shown in FIG. 1 illustrate environment and form no part of the claimed design. The remaining broken lines shown in FIGS. 2-6 illustrate portions of the self-adjusting bridging for floorboard joists that form no part of the claimed design.

1 Claim, 10 Drawing Sheets

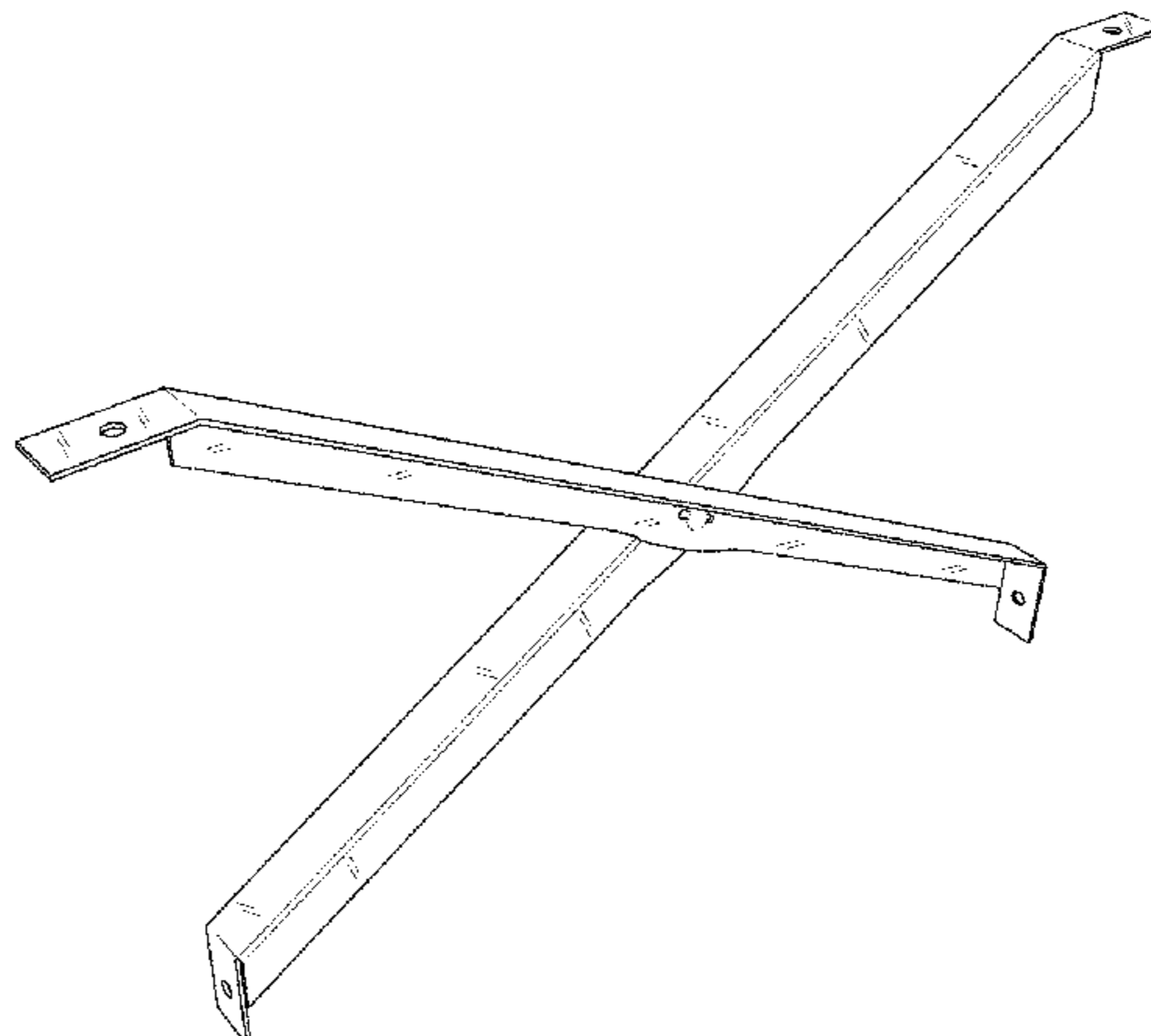

(58) **Field of Classification Search**
 USPC D25/141; 52/289, 474, 481.1, 479, 657,
 52/695, 696, 702, 712, 715; 403/232.1,
 403/237; D8/354, 363, 373, 376, 380,
 D8/382
 CPC E04C 2003/026; E04C 3/02; E04C 2/384;
 E04C 3/18; E04B 5/12; E04B 2001/2415;
 E04B 1/2612; E04D 12/008; E04F
 15/02458; E04G 23/0218
 See application file for complete search history.

(56) **References Cited**
 U.S. PATENT DOCUMENTS

562,971	A	6/1896	Park	
655,693	A	8/1900	Dempster et al.	
1,496,133	A	6/1924	Rothrock	
1,514,577	A *	11/1924	Burrell	E04C 3/02 52/695
1,609,699	A *	12/1926	Coryell	E04C 3/02 52/695
1,642,945	A *	9/1927	Davidson	E04C 3/02 52/127.5
1,725,414	A	8/1929	Parish	
1,729,741	A	10/1929	Heltzel	
2,624,080	A	1/1953	Eichenlaub	
3,155,202	A *	11/1964	Milette	E06B 9/01 211/187

3,367,080	A *	2/1968	McClelland	E04G 5/16 52/645
4,122,647	A *	10/1978	Kovar	E04C 3/02 52/695
4,261,149	A *	4/1981	Gustafson	E04B 1/34352 52/292
4,333,294	A *	6/1982	Robinson	E04C 3/02 52/695
5,505,031	A	4/1996	Heydon	
5,937,608	A *	8/1999	Kucirka	E04B 5/12 52/105
5,946,867	A *	9/1999	Snider, Jr.	E04F 15/02458 52/126.6
6,170,218	B1	1/2001	Shahnazarian	
8,966,856	B2 *	3/2015	Groenesteyn	E04C 3/18 52/643
2007/0022701	A1 *	2/2007	Surowiecki	E04B 2/7457 52/693
2015/0267393	A1 *	9/2015	Bovet	E04F 13/0866 52/126.3
2017/0073969	A1 *	3/2017	Kriston	E04C 3/09

OTHER PUBLICATIONS

Structure Lock X brace I joist; <http://structurelock.com/usa/portfolio/x-brace-i-joist/>.

* cited by examiner

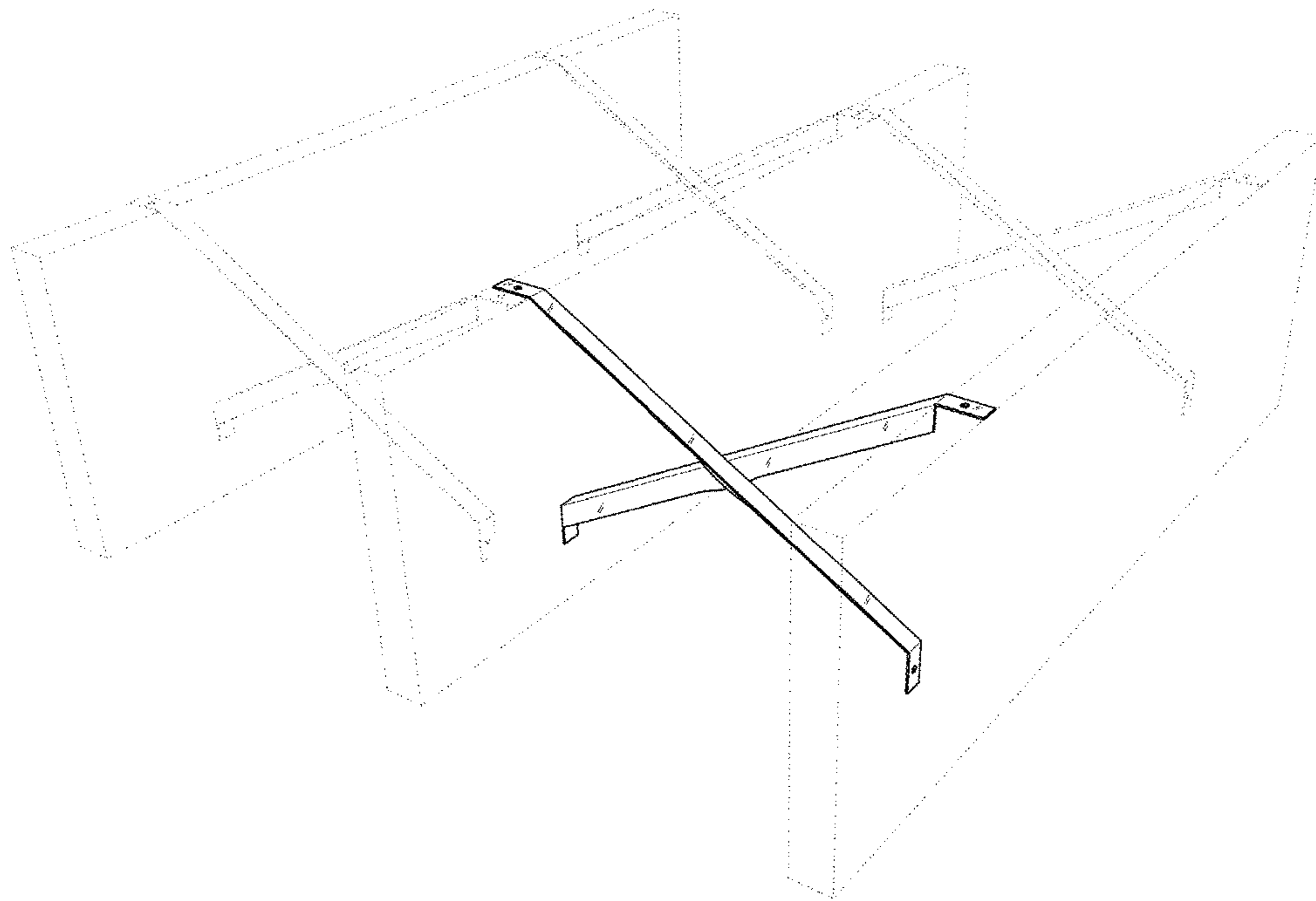

FIG. 1

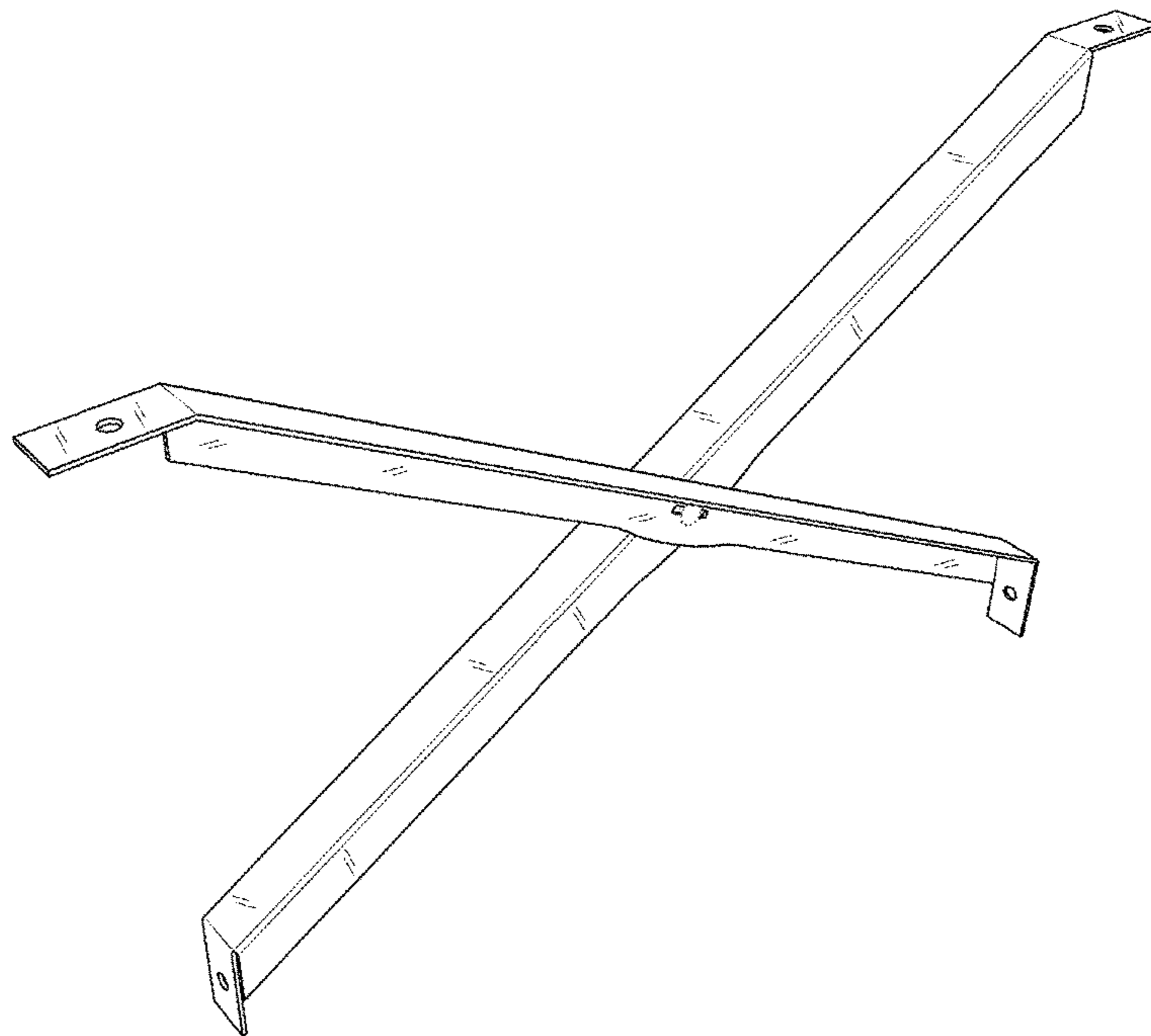

FIG. 2

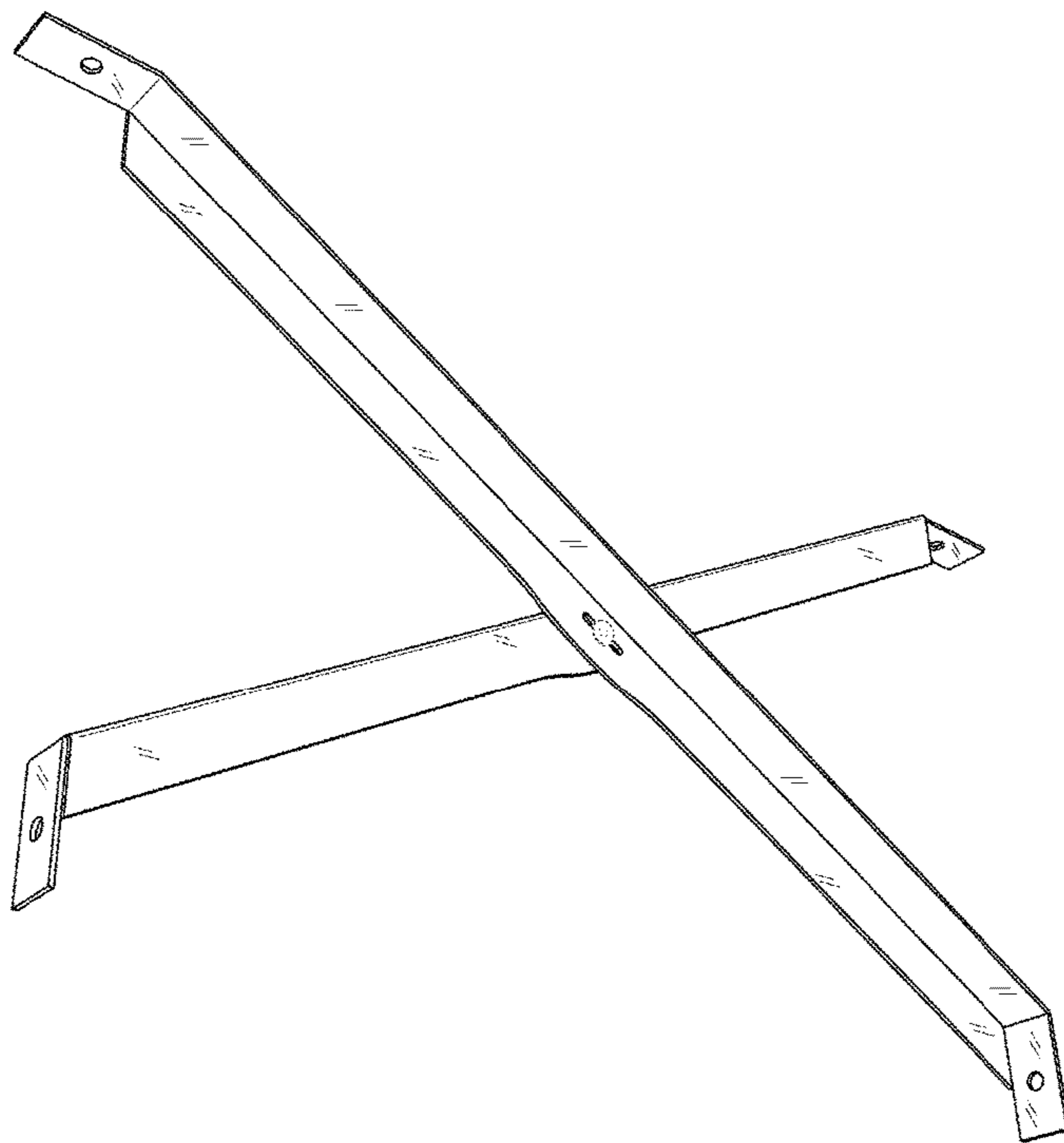

FIG. 3

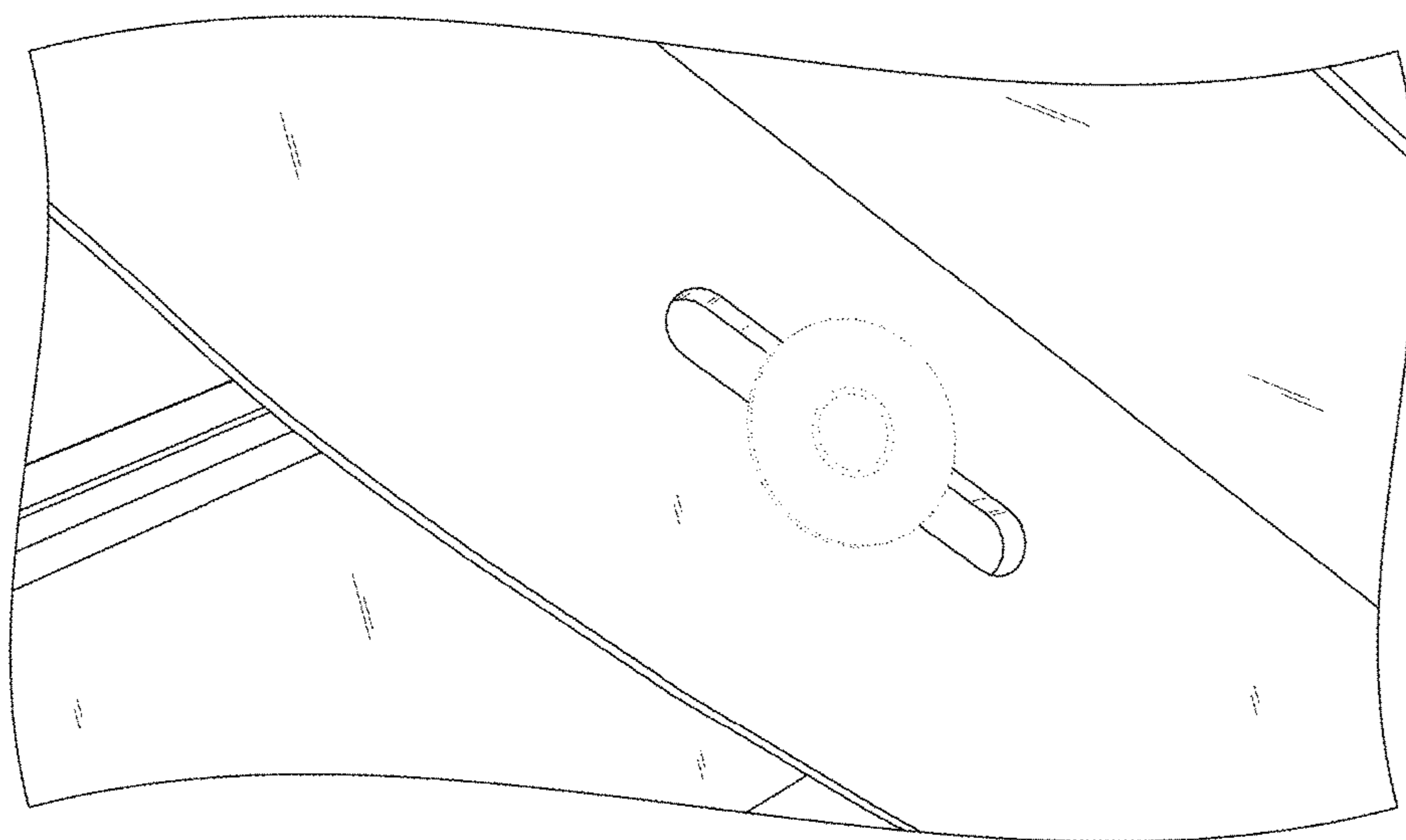

FIG. 4

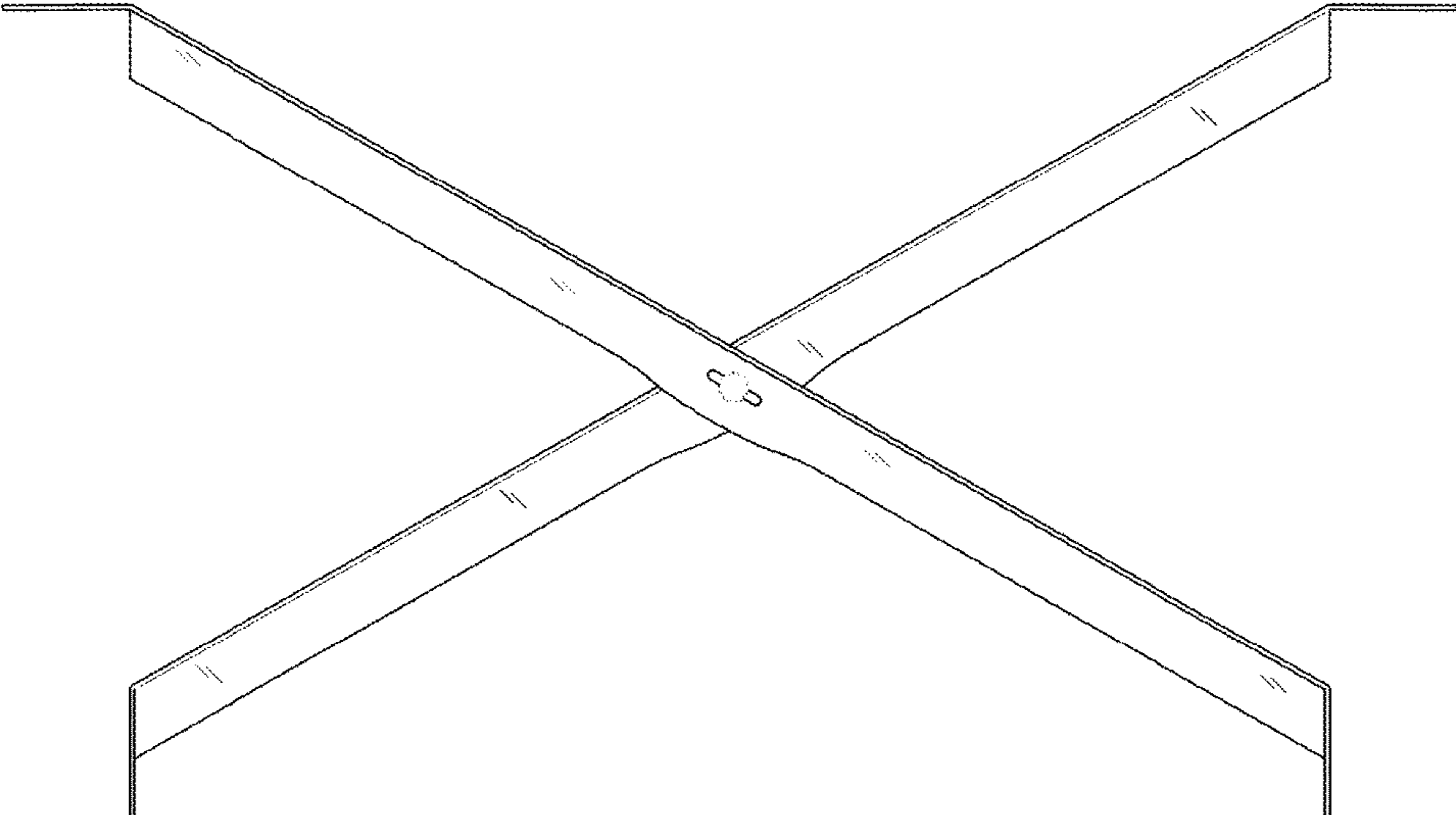

FIG. 5

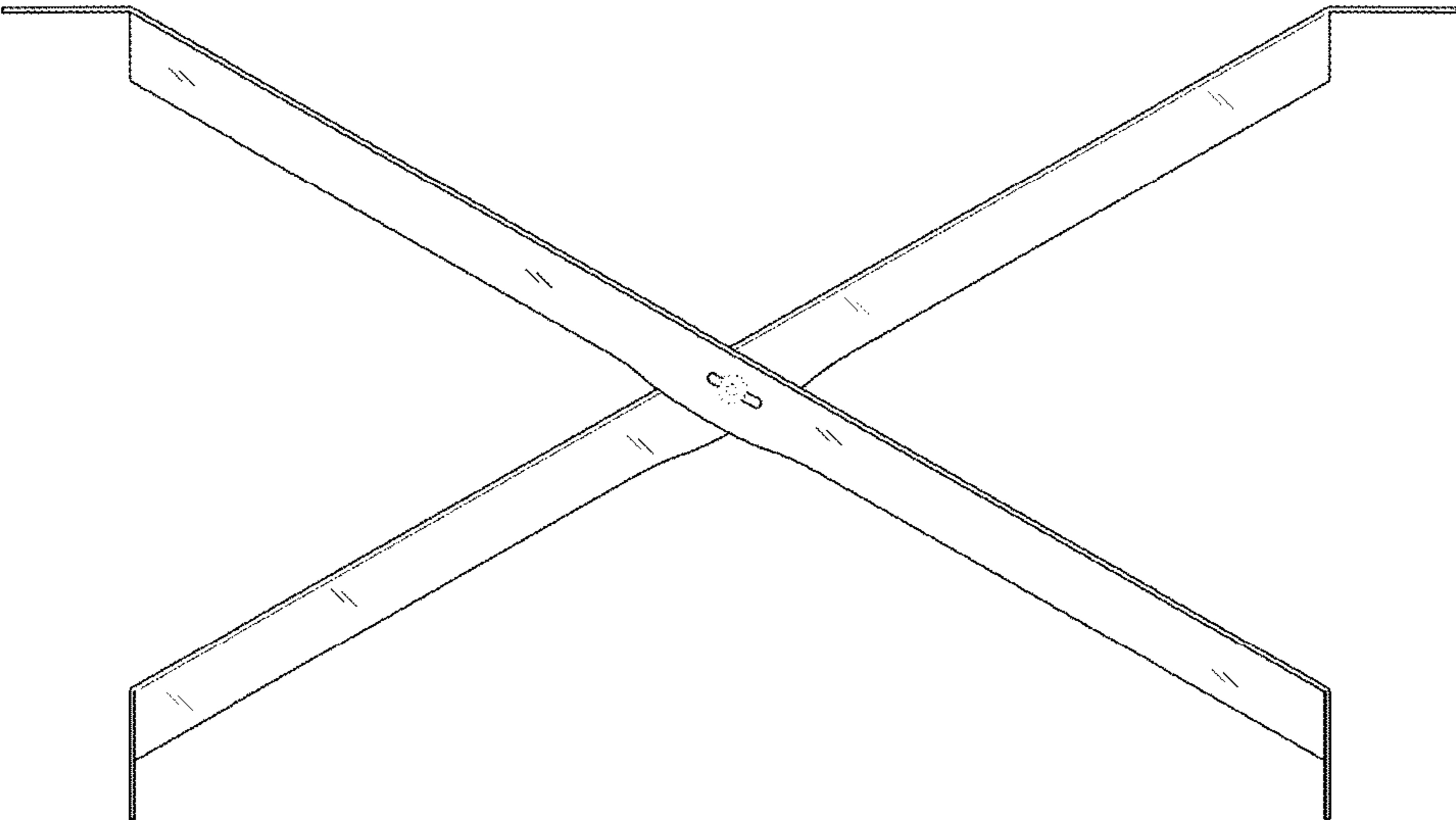

FIG. 6

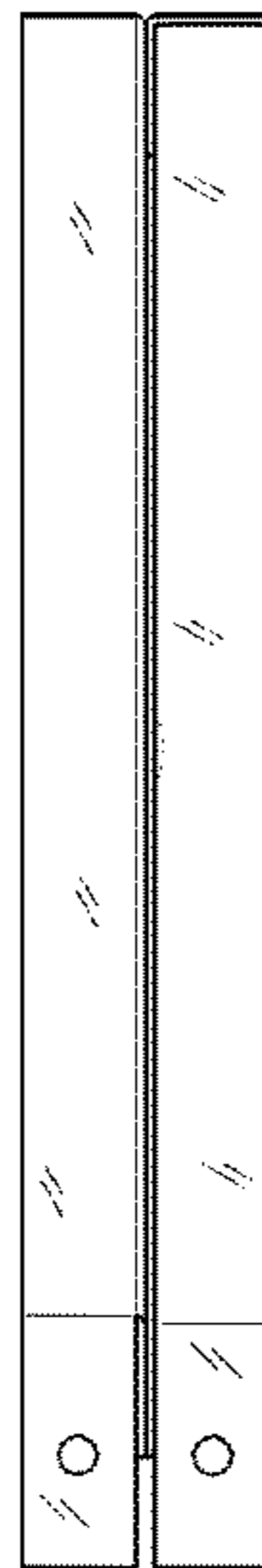

FIG. 7

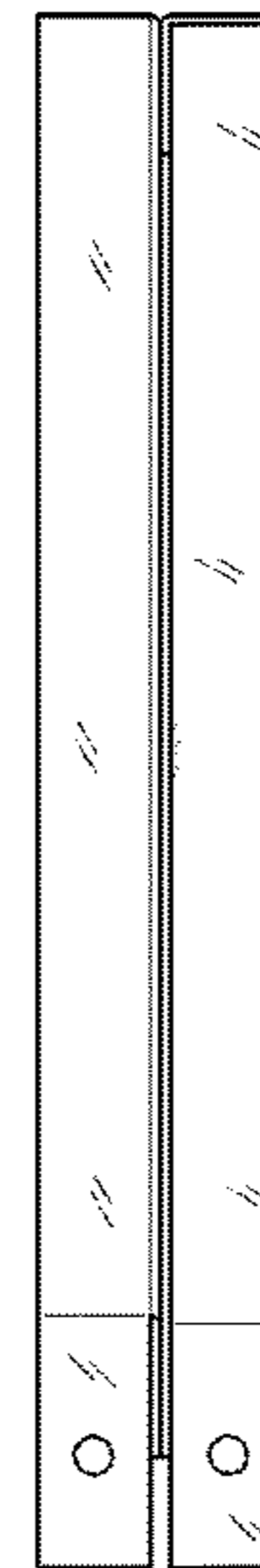

FIG. 8

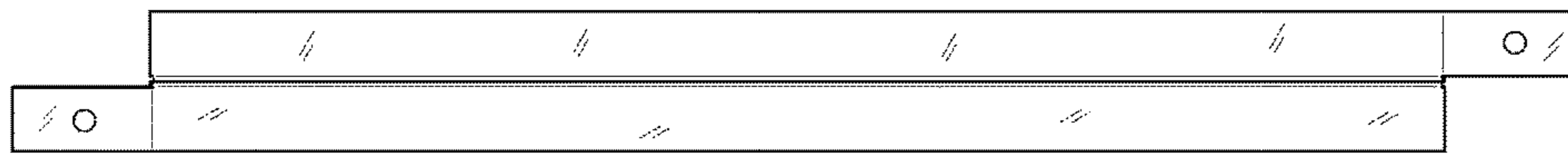

FIG. 9

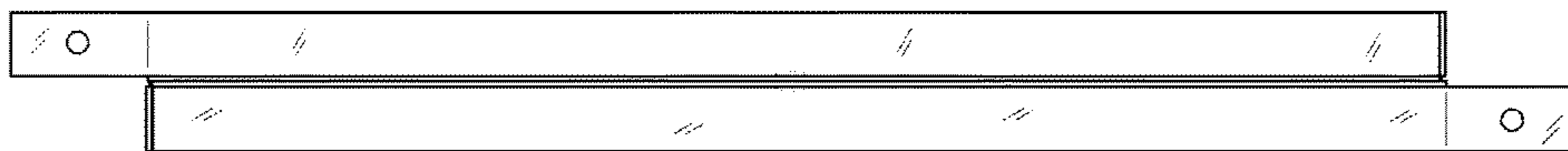

FIG. 10

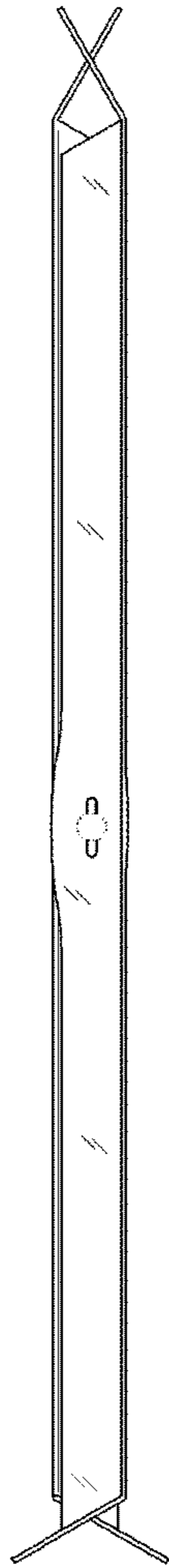

FIG. 11

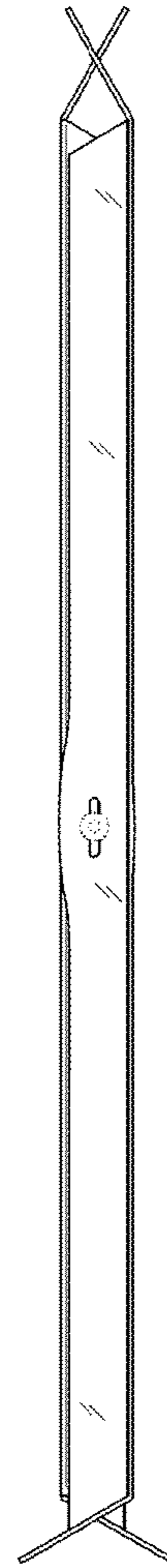

FIG. 12

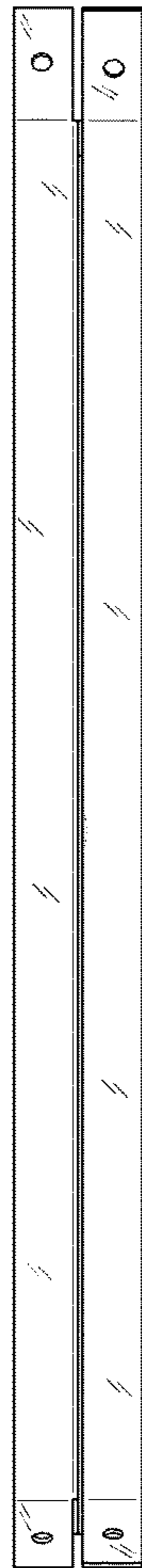

FIG. 13

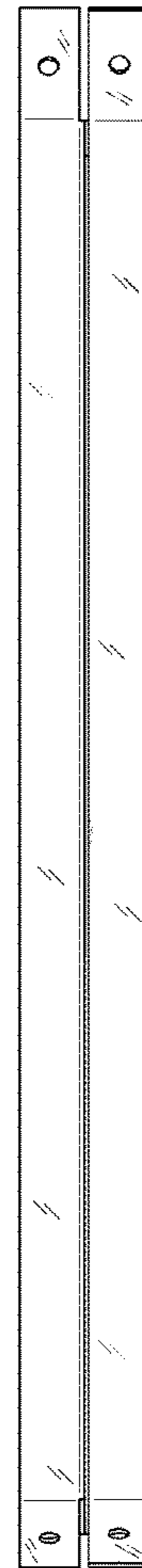

FIG. 14

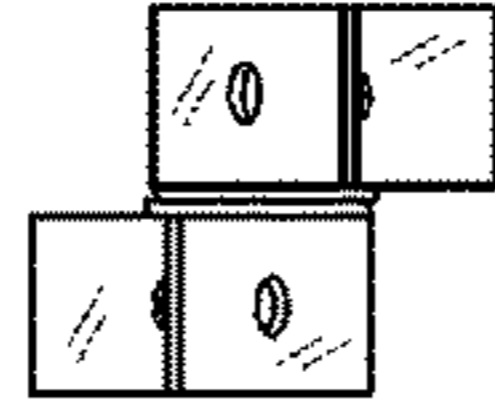

FIG. 15

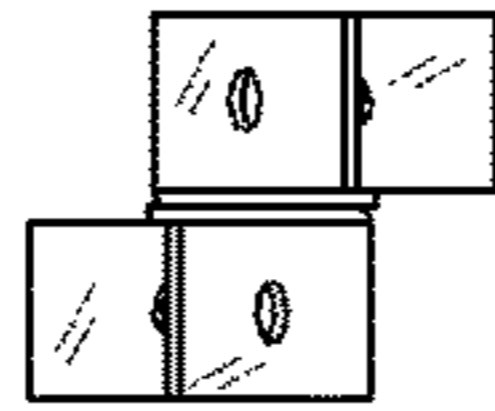

FIG. 16