



US00D852768S

(12) **United States Design Patent**
Watanabe

(10) **Patent No.:** **US D852,768 S**
(45) **Date of Patent:** **** Jul. 2, 2019**

(54) **ELECTRONIC GAME STATION**
(71) Applicant: **SEGA SAMMY CREATION INC.,**
Tokyo (JP)

D835,069 S * 12/2018 Won D14/215
D835,606 S * 12/2018 Won D14/215
D836,605 S * 12/2018 Kim D14/215
D836,607 S * 12/2018 Kim D14/216

(72) Inventor: **Katsuhiko Watanabe,** Tokyo (JP)

* cited by examiner

(**) Term: **15 Years**

Primary Examiner — Michael A. Pratt

(21) Appl. No.: **35/504,602**

(22) Filed: **Sep. 12, 2017**

(57) **CLAIM**

(80) **Hague Agreement Data**

The ornamental design for an electronic game station, as shown and described.

Int. Filing Date: **Sep. 12, 2017**
Int. Reg. No.: **DM/097940**
Int. Reg. Date: **Sep. 12, 2017**
Int. Reg. Pub. Date: **Mar. 16, 2018**

DESCRIPTION

(51) **LOC (11) Cl.** **14-02**

(52) **U.S. Cl.**
USPC **D14/133**

(58) **Field of Classification Search**
USPC D14/133, 204, 209.1, 210, 211, 212,
D14/213-217, 221, 224
CPC ... H04R 1/26; H04R 5/00; H04R 5/02; H04R
1/02; H04R 1/28; H04R 7/26
See application file for complete search history.

- 1. Electronic game station
- 1.1 : Perspective
- 1.2 : Front
- 1.3 : Back
- 1.4 : Top
- 1.5 : Bottom
- 1.6 : Right
- 1.7 : Left

The broken lines do not form part of the claimed design; the present article is an electronic game station which outputs image data, voice data, etc., in response to input by the player; the present article comprises the speaker unit located between the main body and the display provided on the upper part of the main body.

(56) **References Cited**

U.S. PATENT DOCUMENTS

D470,895 S * 2/2003 Cole D21/325
D825,527 S * 8/2018 Won D14/215

1 Claim, 7 Drawing Sheets

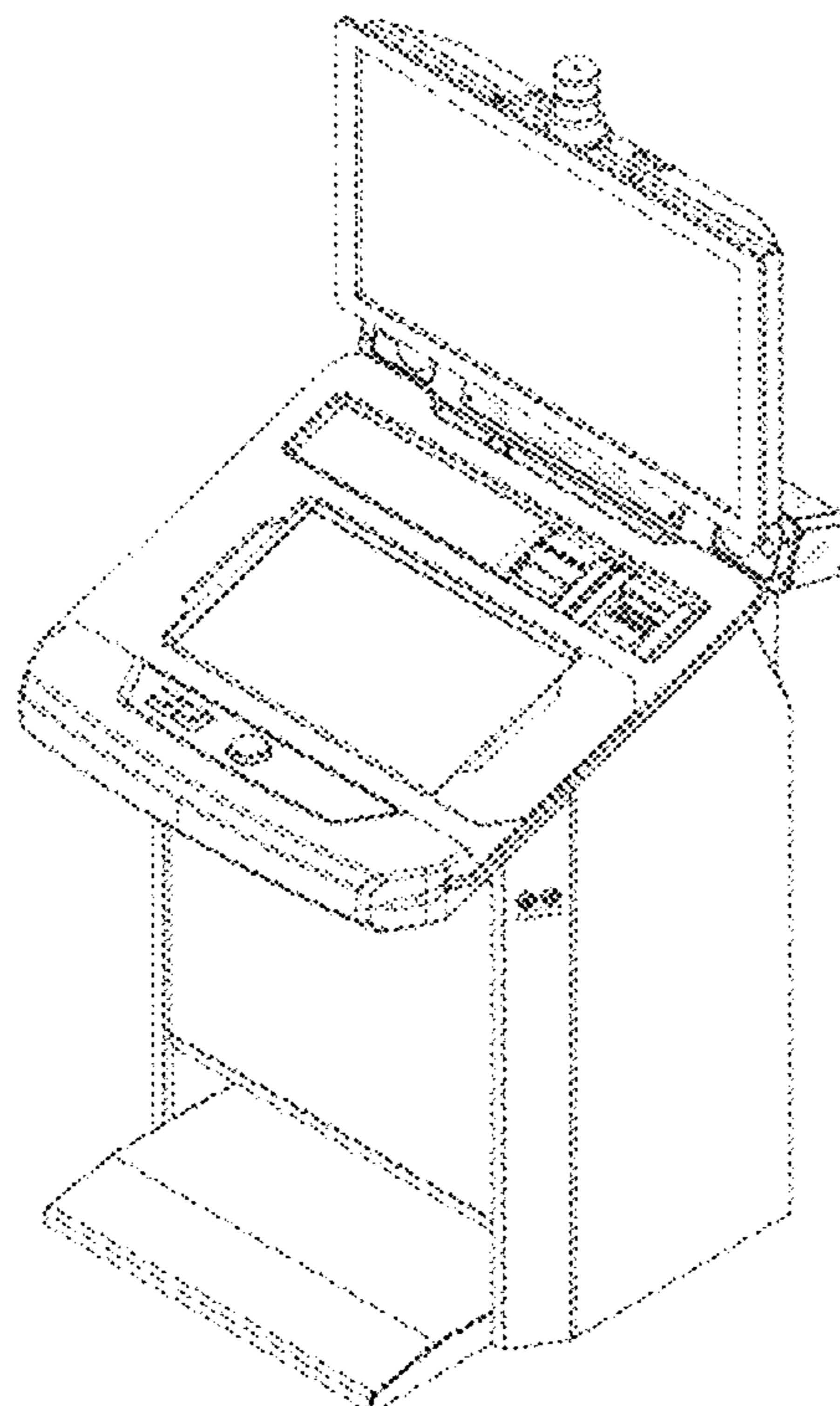

1.1

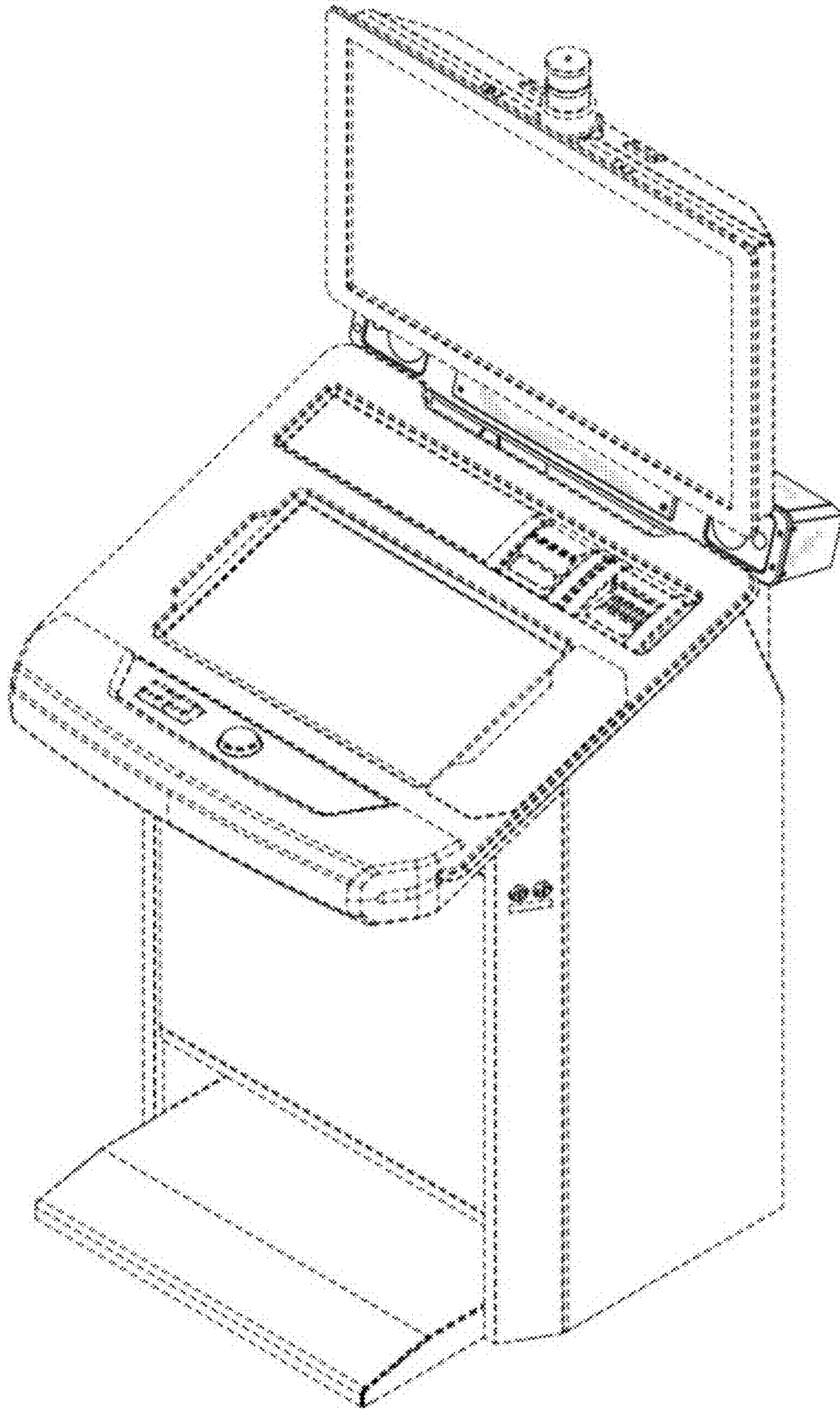

1.2

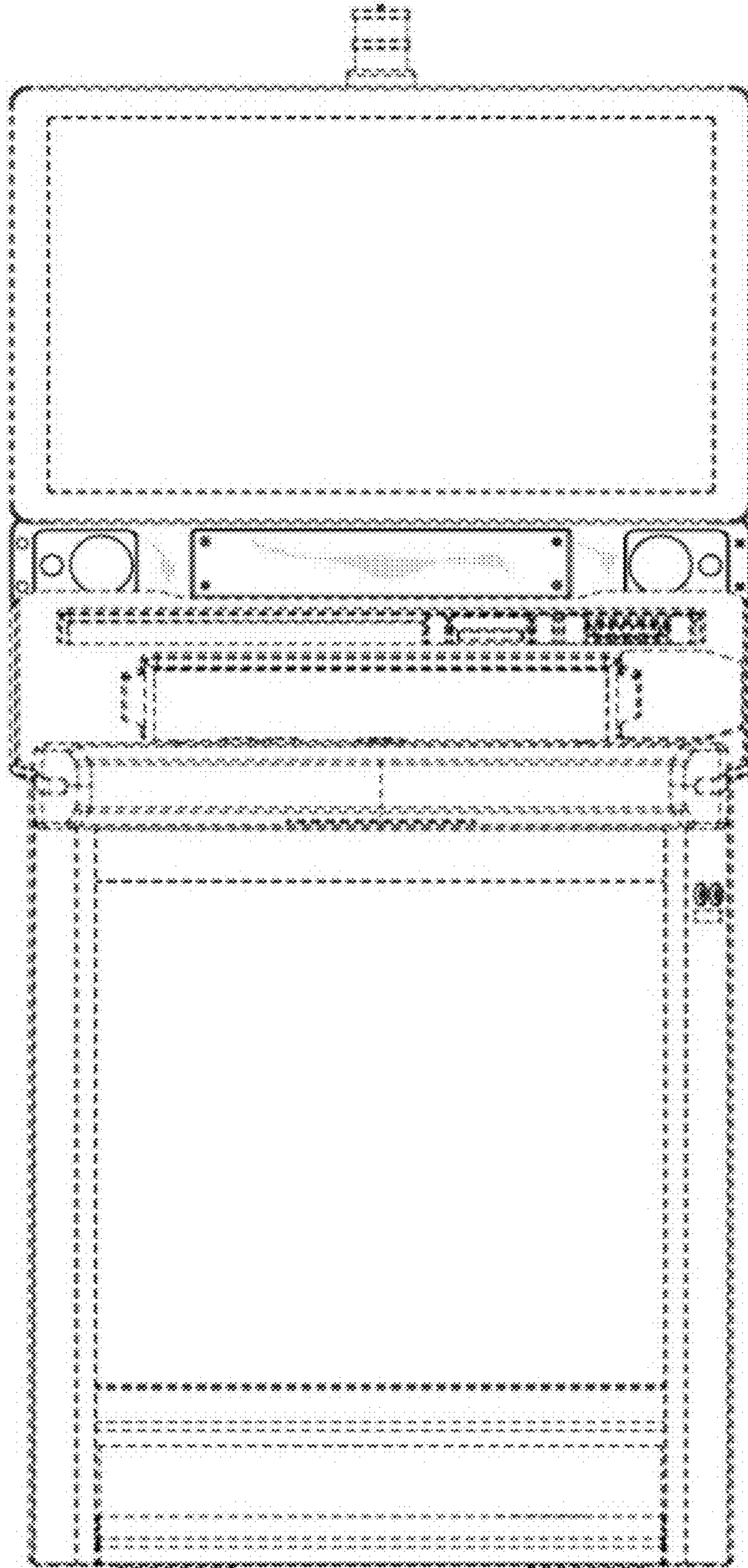

1.3

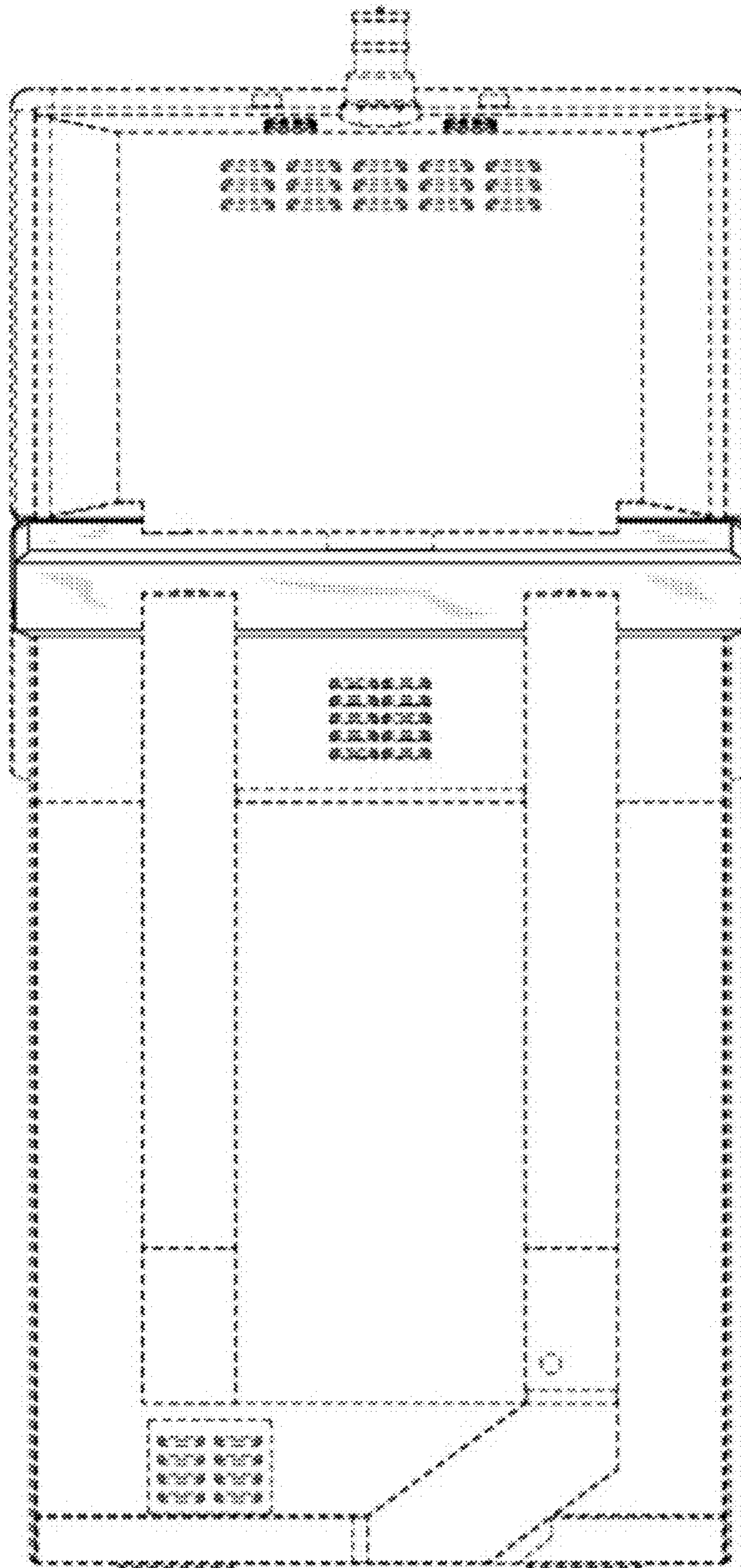

1.4

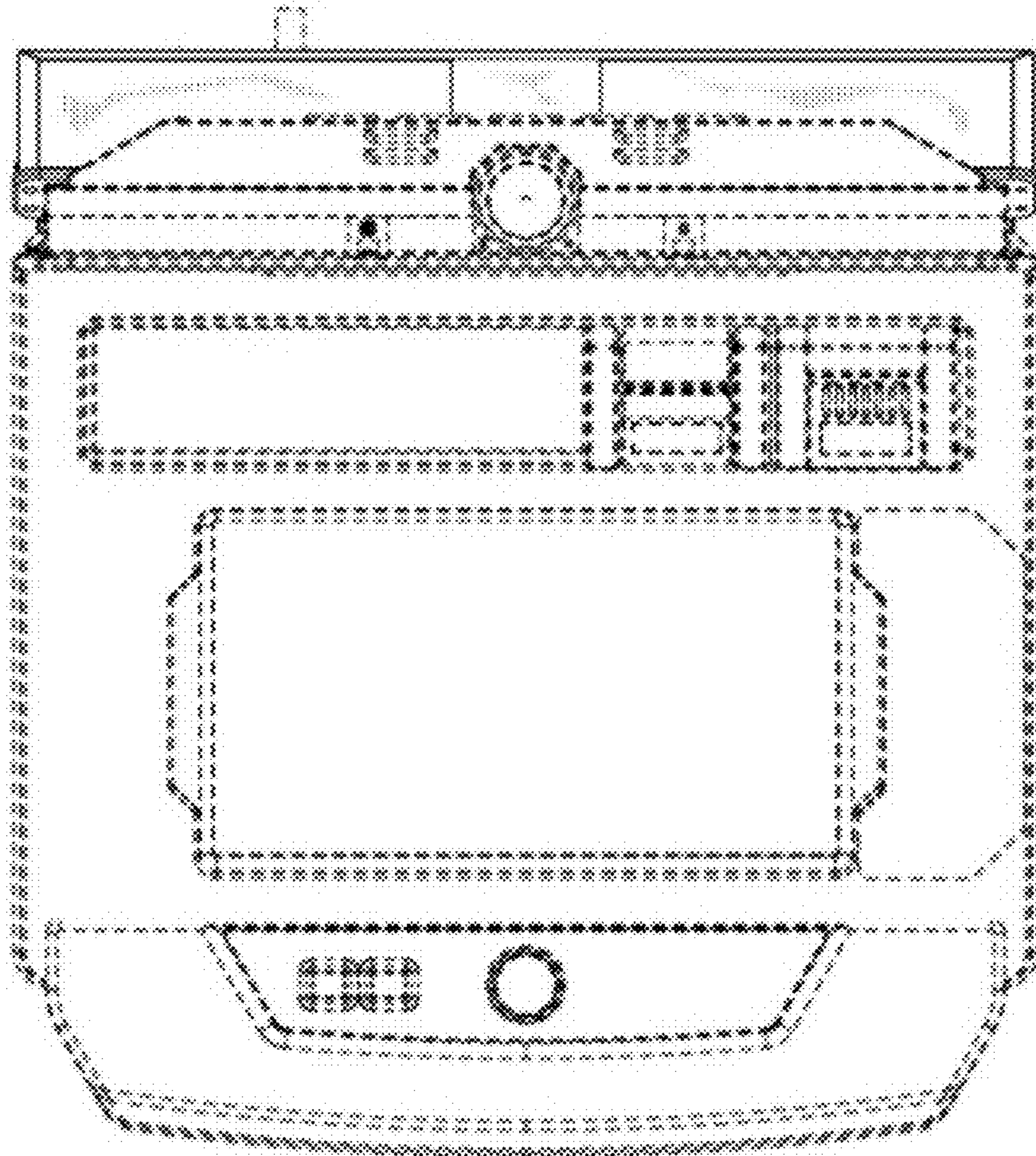

1.5

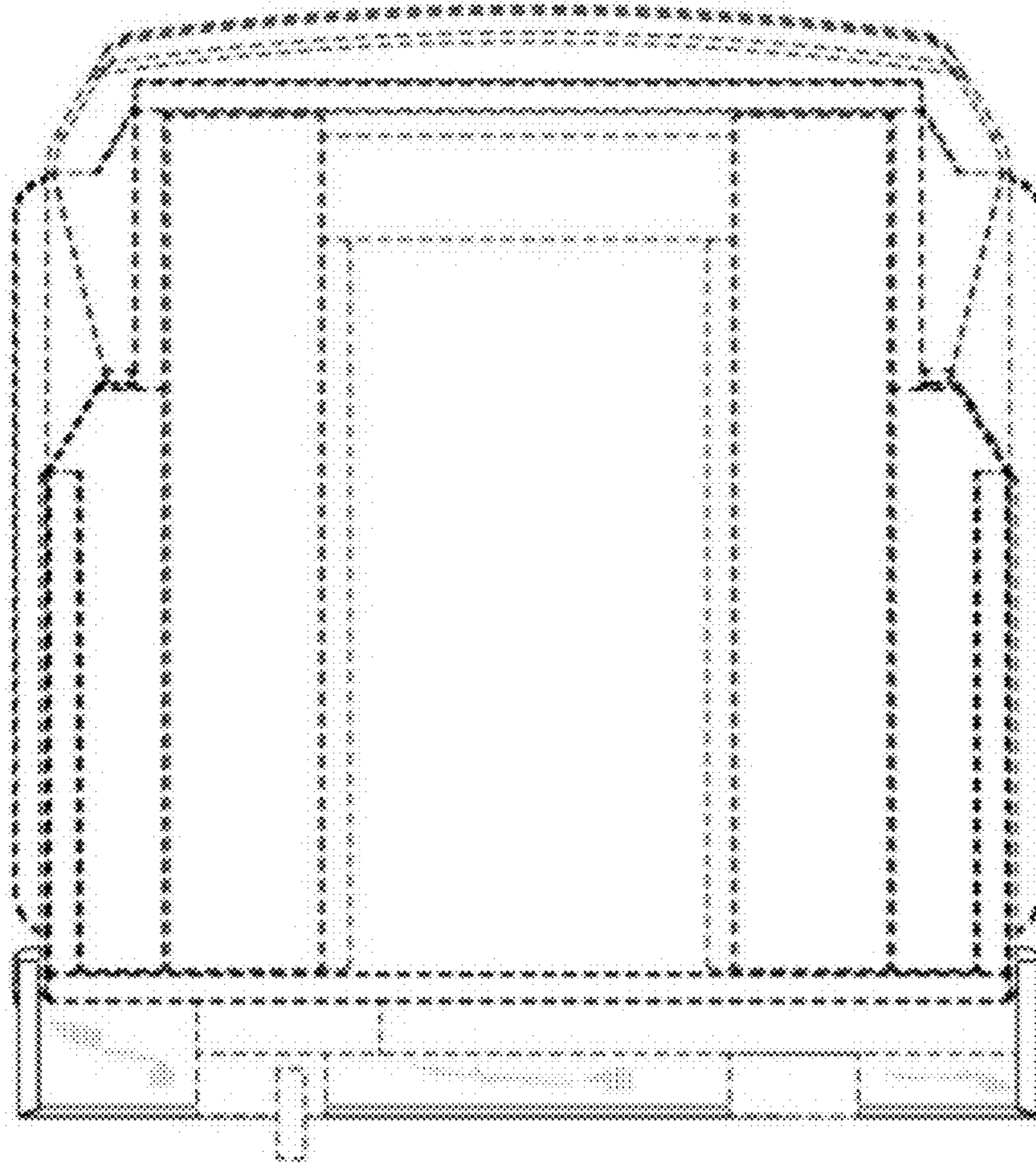

1.6

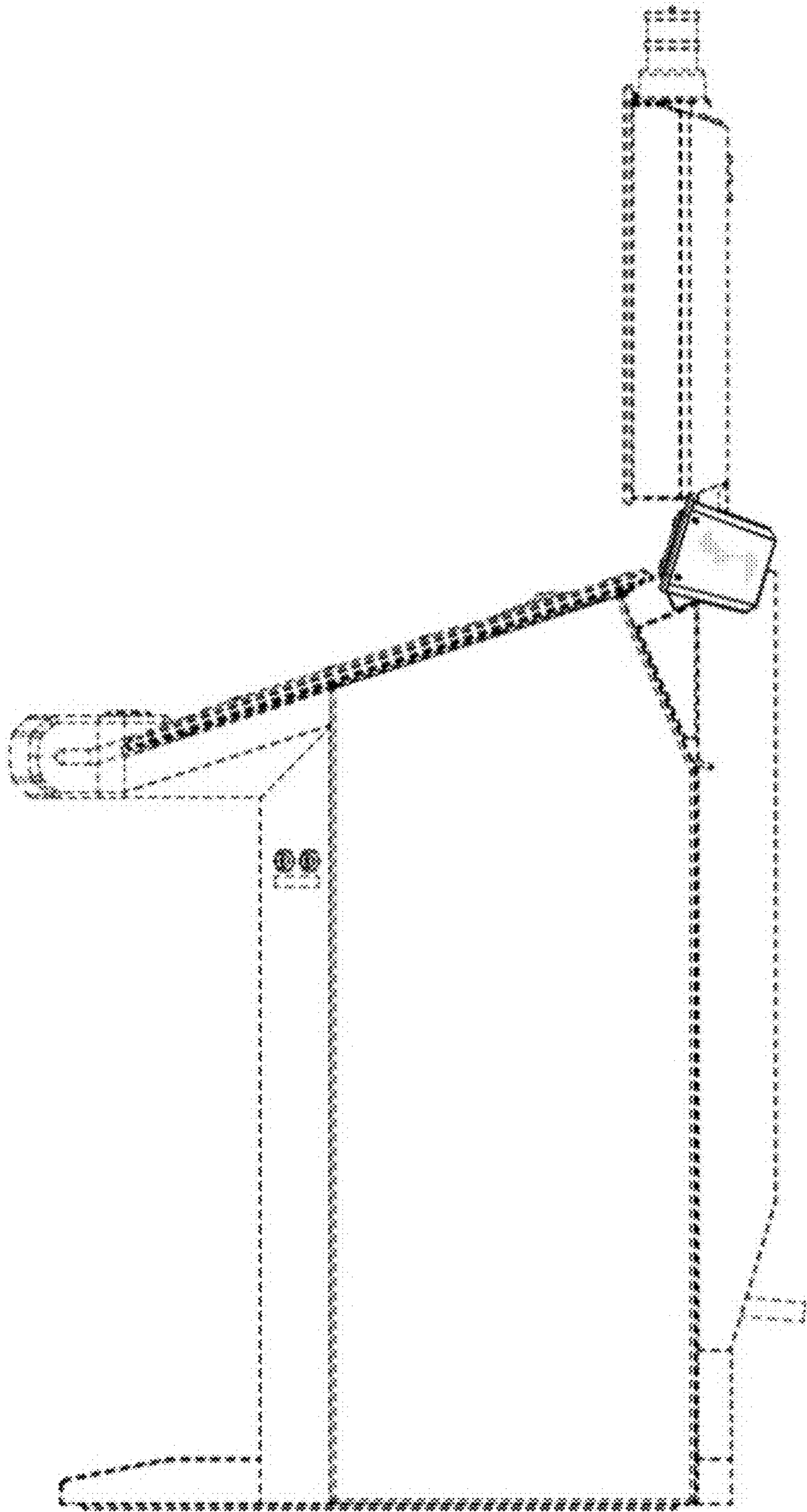

1.7

