



US00D852601S

(12) **United States Design Patent** (10) **Patent No.:** **US D852,601 S**
Son et al. (45) **Date of Patent:** **** Jul. 2, 2019**

(54) **POLISHING PAD**
(71) Applicant: **EHWA Diamond Ind. Co., Ltd.**,
Osan-si (KR)
(72) Inventors: **Jun Seok Son**, Hwaseong-si (KR);
Jang Hyuk Ahn, Hwaseong-si (KR)
(73) Assignee: **EHWA Diamond Ind. Co., Ltd.**,
Osan-si (KR)
(**) Term: **15 Years**
(21) Appl. No.: **29/623,145**
(22) Filed: **Oct. 23, 2017**

(30) **Foreign Application Priority Data**

Apr. 24, 2017 (KR) 30-2017-0018883

(51) **LOC (11) Cl.** **08-05**

(52) **U.S. Cl.**
USPC **D8/70**

(58) **Field of Classification Search**
USPC D8/20, 61, 62, 63, 70; D15/124, 125,
D15/126, 132, 138, 139, 140
CPC B24D 9/08; B24B 55/102
See application file for complete search history.

(56) **References Cited**

U.S. PATENT DOCUMENTS

7,147,548 B1 * 12/2006 Mehrabi B24B 7/186
451/323
D579,296 S * 10/2008 Popov D8/70
D592,029 S * 5/2009 Tano D8/70
D592,030 S * 5/2009 Tano D8/70
D678,745 S * 3/2013 Nguyen D8/70
D684,739 S * 6/2013 Arnold D32/25
D732,917 S 6/2015 Valentini
D795,666 S * 8/2017 Tchakarov D8/70
D803,652 S * 11/2017 Umbrell D8/70

D804,923 S * 12/2017 Umbrell D8/70
D804,925 S * 12/2017 Umbrell D8/70
D808,236 S * 1/2018 Schumacher D8/70
D813,634 S * 3/2018 Umbrell D8/70
D837,015 S * 1/2019 Tchakarov D8/70
2007/0254568 A1 * 11/2007 Park B24D 7/066
451/548
2010/0144253 A1 * 6/2010 Umbrell B24D 13/14
451/360
2011/0300784 A1 * 12/2011 Tchakarov B24B 7/186
451/259
2013/0225051 A1 * 8/2013 Vankouwenberg B24D 11/02
451/350
2013/0324021 A1 * 12/2013 Ryan B24D 11/00
451/529
2017/0014974 A1 * 1/2017 Luna B24D 13/145

* cited by examiner

Primary Examiner — Darlington Ly

(74) *Attorney, Agent, or Firm* — The Webb Law Firm

(57) **CLAIM**

The ornamental design for a polishing pad, as shown and described.

DESCRIPTION

FIG. 1 is a front perspective view of a polishing pad, showing our new design;
FIG. 2 is a front elevation view thereof;
FIG. 3 is a rear elevation view thereof;
FIG. 4 is a left side elevation view thereof;
FIG. 5 is a right side elevation view thereof;
FIG. 6 is a top plan view thereof;
FIG. 7 is a bottom plan view thereof; and,
FIG. 8 is a perspective view of a plurality thereof in their intended environment.

The broken line showings in FIG. 8 are for the purpose of illustrating environmental structure and form no part of the claimed design.

1 Claim, 8 Drawing Sheets

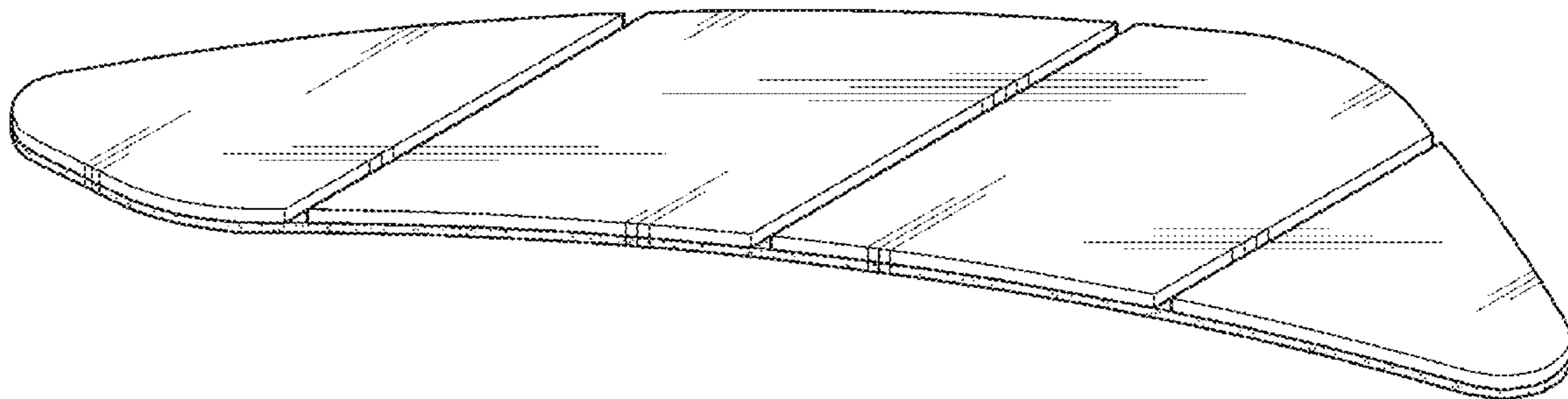

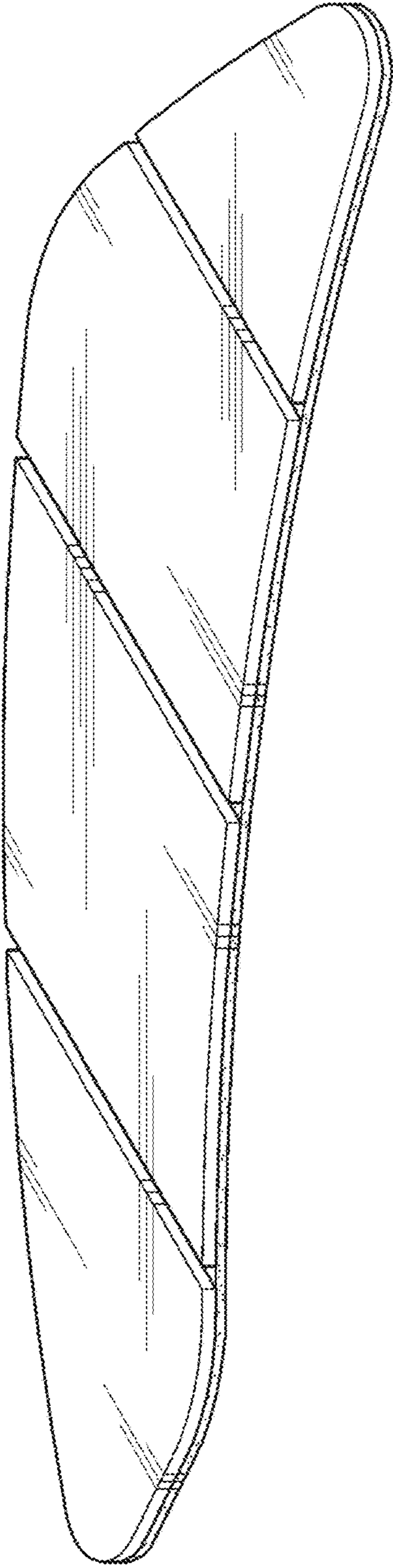

FIG. 1

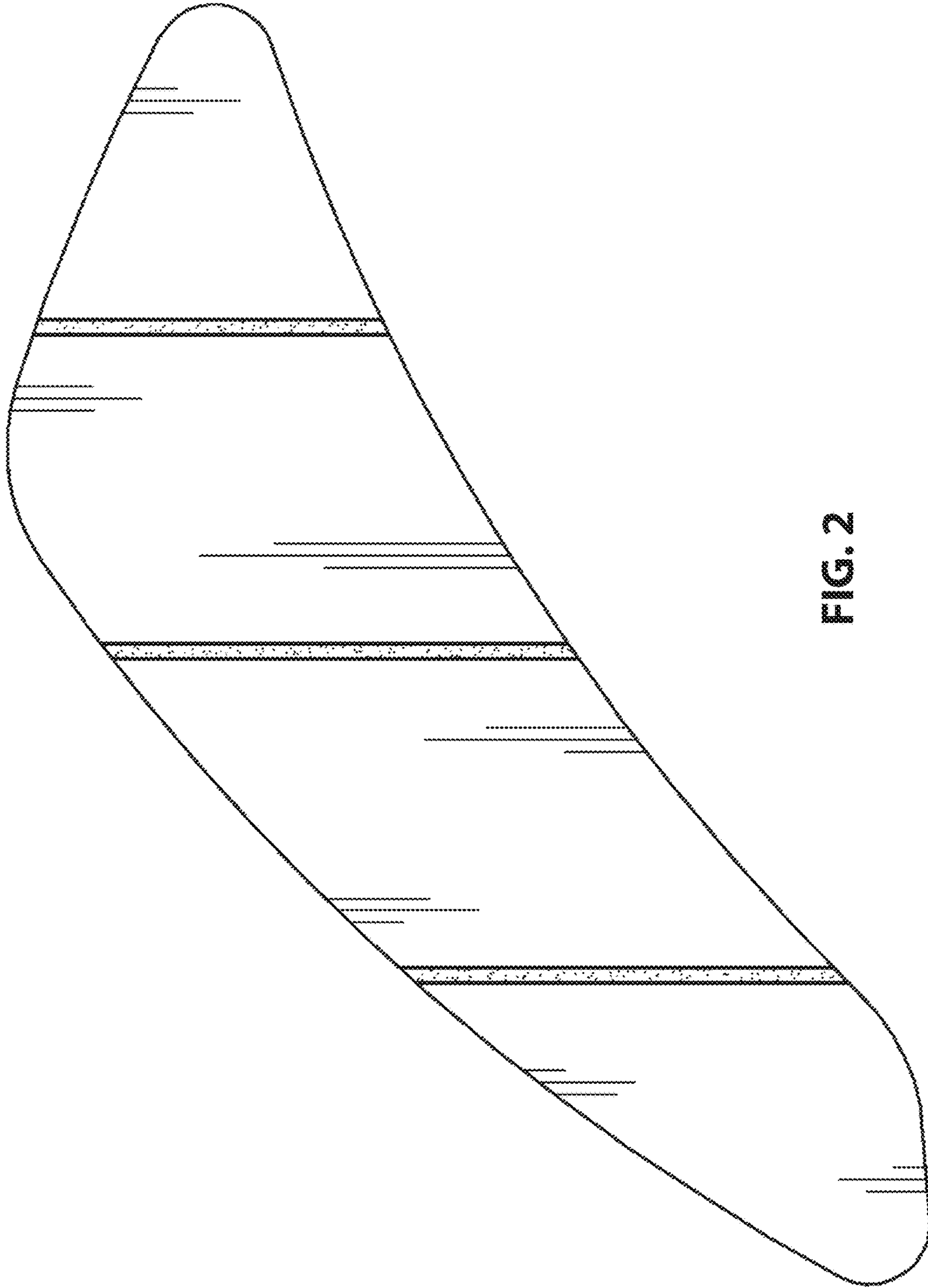

FIG. 2

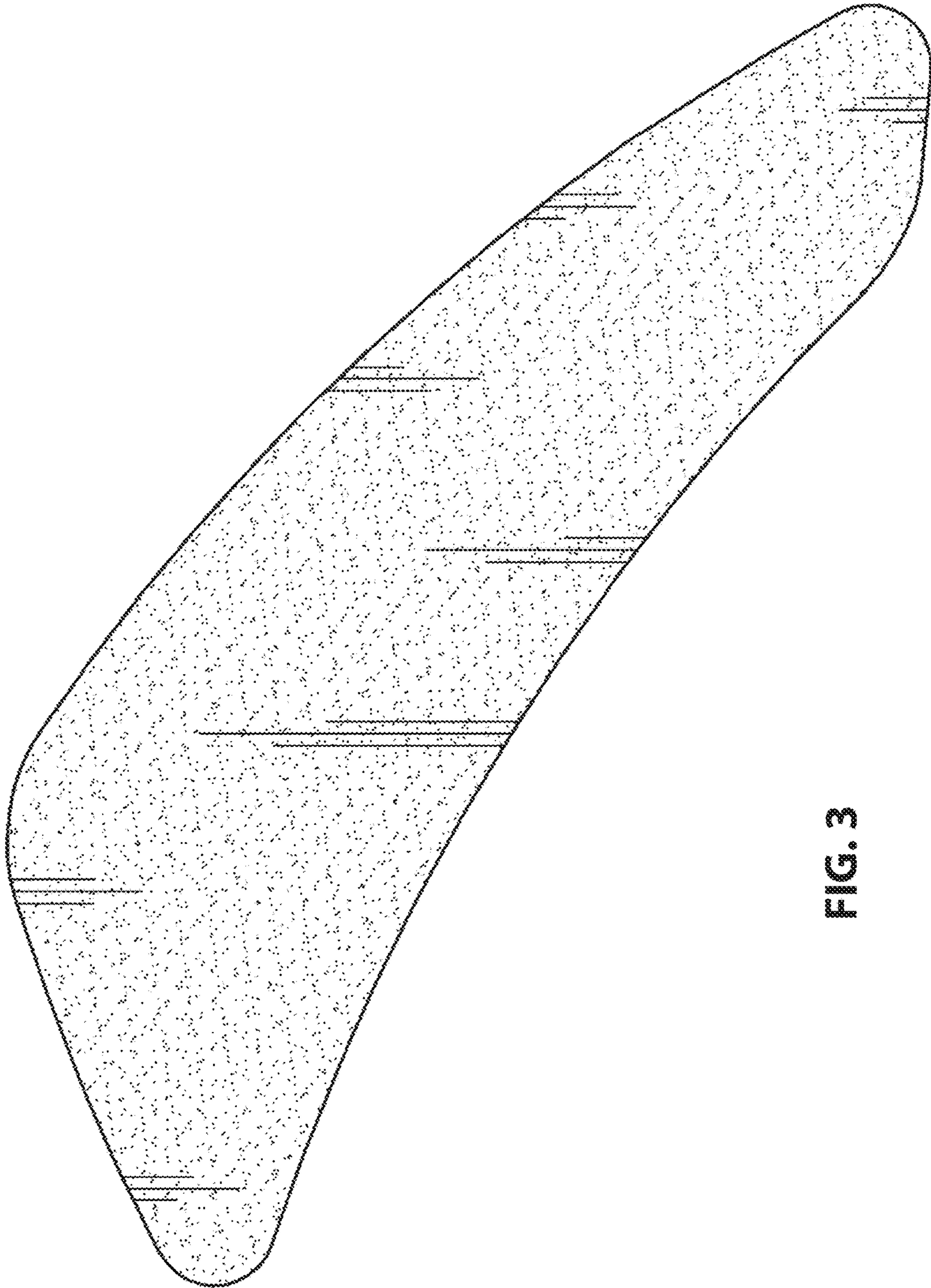

FIG. 3

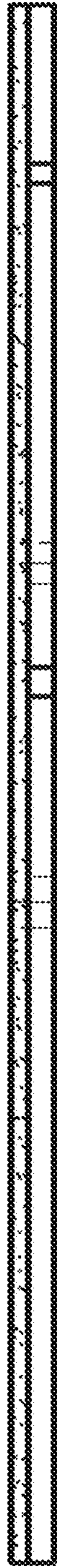

FIG. 4



FIG. 5



FIG. 6



FIG. 7

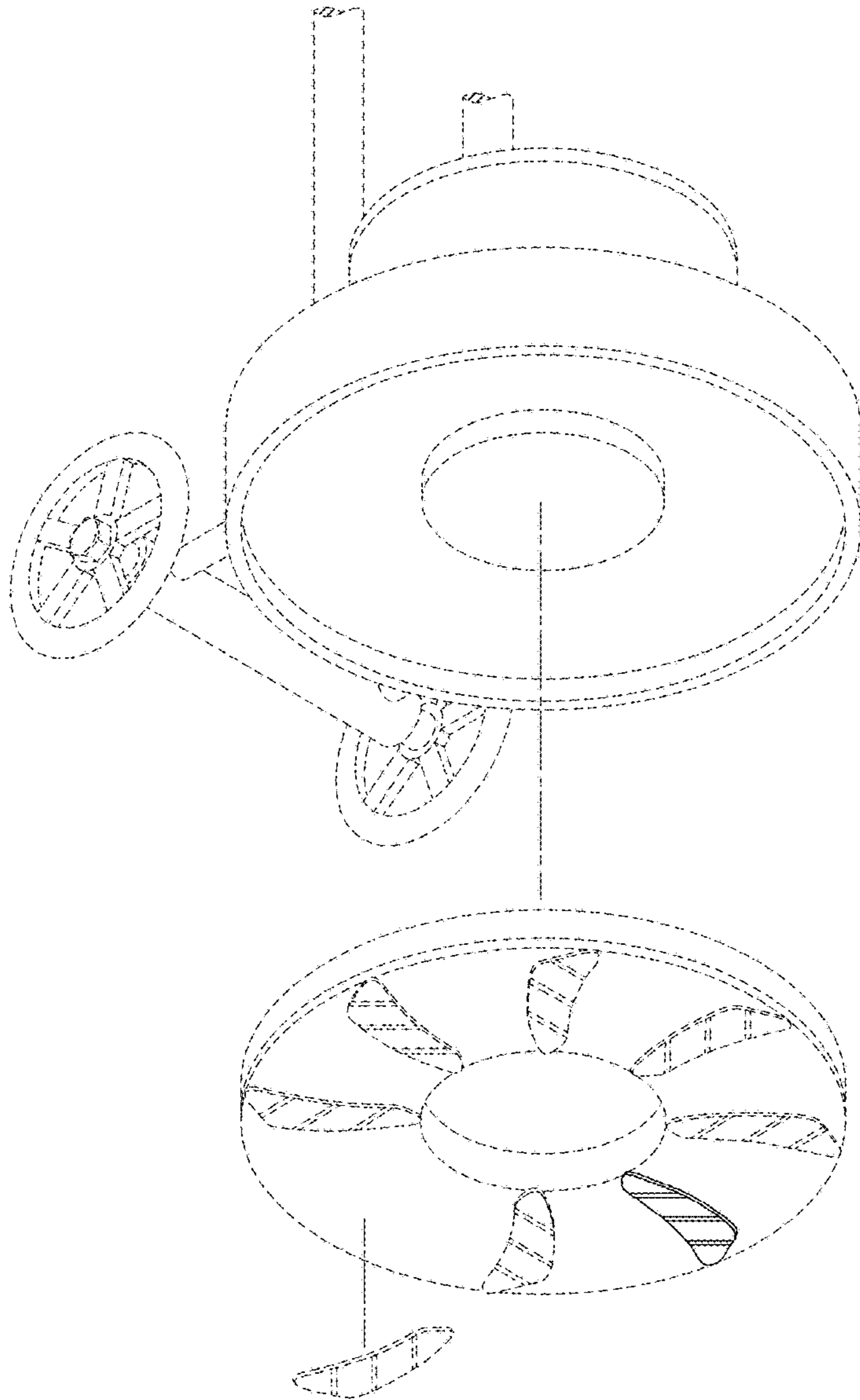

FIG. 8