

US00D852427S

(12) **United States Design Patent** (10) **Patent No.:** **US D852,427 S**
Harder et al. (45) **Date of Patent:** **** Jun. 25, 2019**

(54) **FIRE PREVENTION KIT**

(56) **References Cited**

(71) Applicant: **Abraham Harder**, Rodenrijs (NL)

U.S. PATENT DOCUMENTS

(72) Inventors: **Abraham Harder**, Rodenrijs (NL);
Flip Ziedses Des Plantes, Amsterdam (NL)

D647,407 S *	10/2011	Toh	D9/688
D702,506 S *	4/2014	Mettler	D7/608
D759,902 S *	6/2016	Kim	D29/125
D760,007 S *	6/2016	Barratt	D29/126
D813,436 S *	3/2018	Verelst	D26/72
D818,775 S *	5/2018	Woodruff	D7/510

(73) Assignee: **ECOPEOPLE, B.V.**, Ep Berkel en Rodenrijs (NL)

* cited by examiner

(**) Term: **15 Years**

Primary Examiner — Randall H Gholson

(21) Appl. No.: **29/616,565**

(74) *Attorney, Agent, or Firm* — Law Offices of Steven W. Weinrieb

(22) Filed: **Sep. 7, 2017**

(57) **CLAIM**

(51) **LOC (11) Cl.** **29-01**

The ornamental design for a fire prevention kit, as shown and described.

(52) **U.S. Cl.**

USPC **D29/125**

(58) **Field of Classification Search**

DESCRIPTION

USPC D23/355-369, 213, 214, 223, 224, 225, D23/231; D28/5, 6; 261/DIG. 17, 261/DIG. 42, DIG. 65, DIG. 88, DIG. 89, 261/DIG. 47, DIG. 55, DIG. 70; 392/356, 392/390, 392, 394, 395; 239/34, 44, 53, 239/55, 56, 326, 60, 308, 589; D9/687, D9/600, 695; D7/591; D29/125, 126, D29/129, 130; 169/7, 89; 222/210, 324
 CPC .. A62C 2/00; A62C 8/00; A62C 13/76; A62C 13/64

FIG. 1 is a right side elevational view of the fire prevention kit showing my new design;
 FIG. 2 is a left side perspective elevational view thereof;
 FIG. 3 is a top plan view thereof when the upper half portion of the kit is disposed at its closed position;
 FIG. 4 is a top perspective view thereof when the upper half portion of the kit is disposed at its open position; and,
 FIG. 5 is a bottom plan view thereof.

See application file for complete search history.

1 Claim, 5 Drawing Sheets

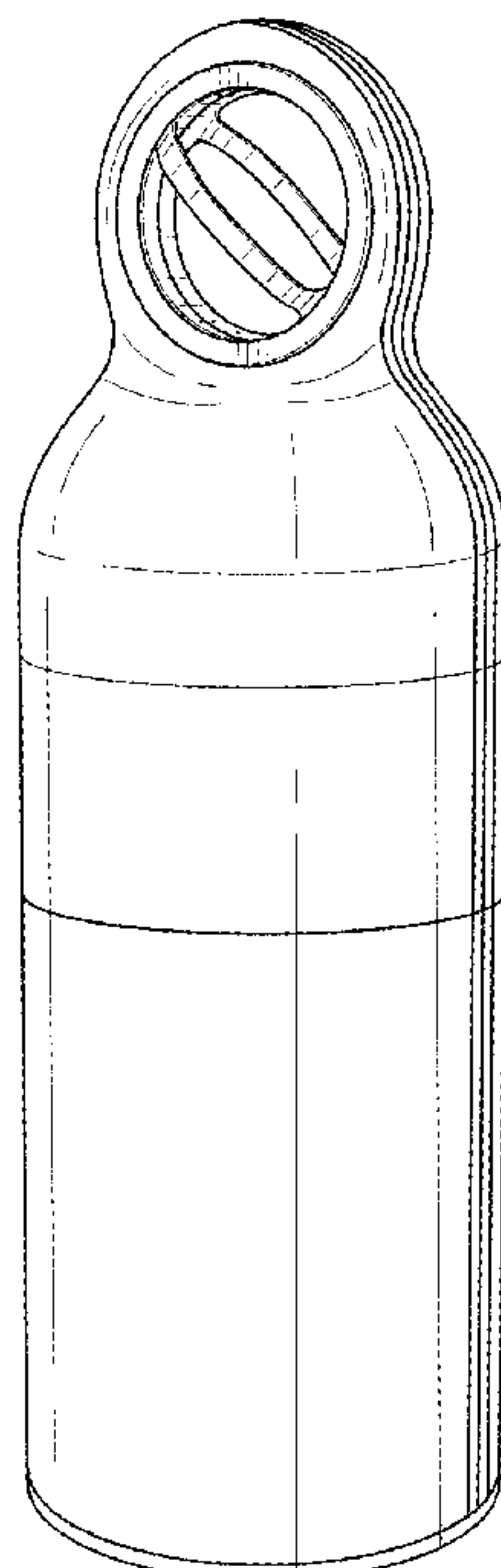

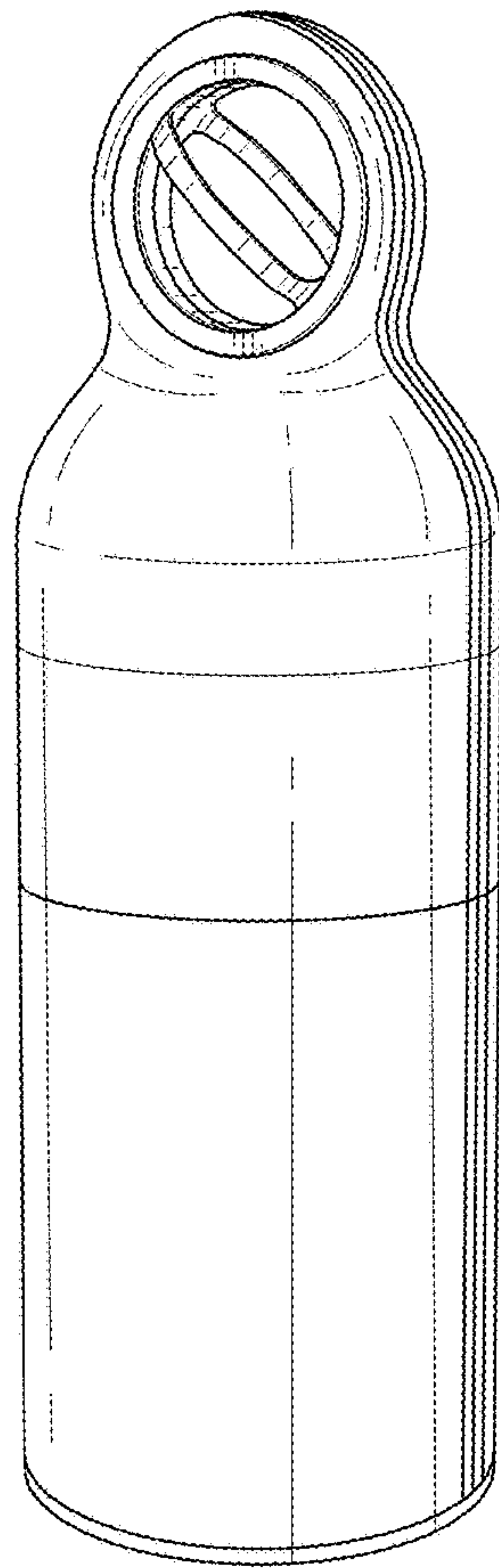

FIG. 1

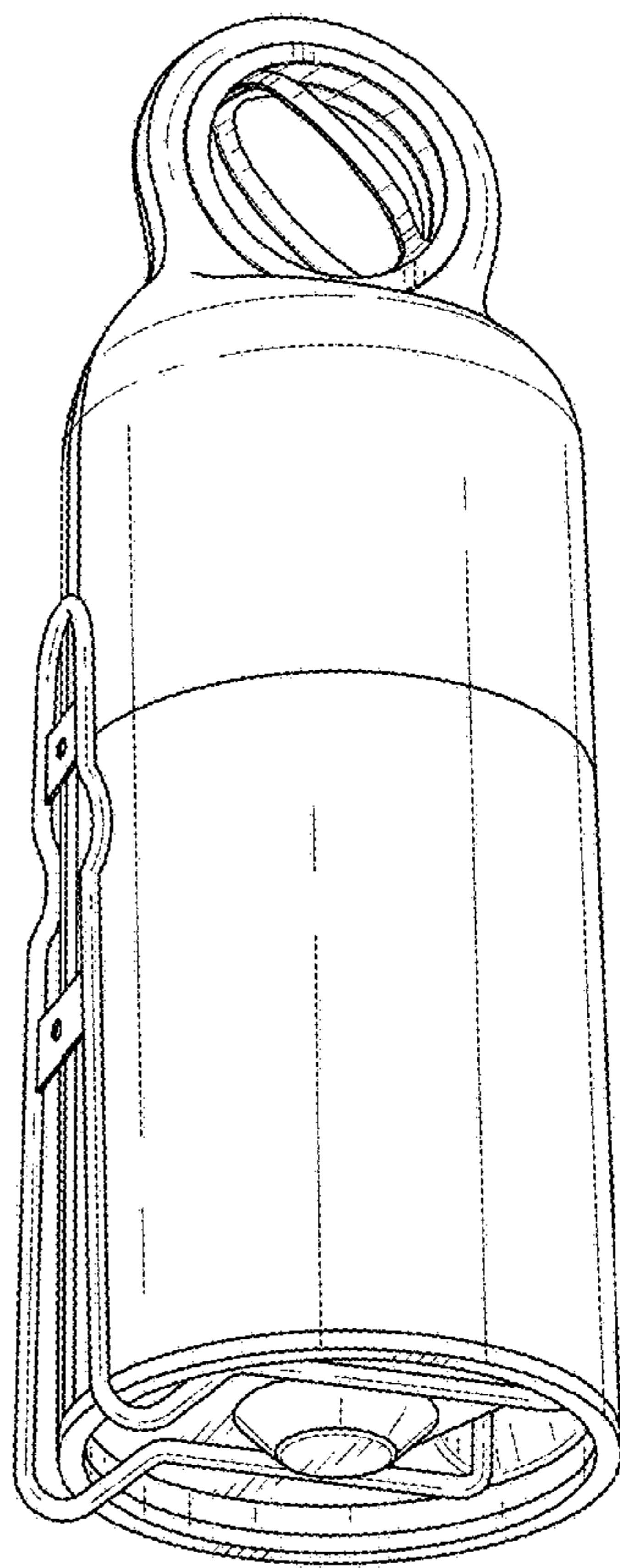

FIG. 2

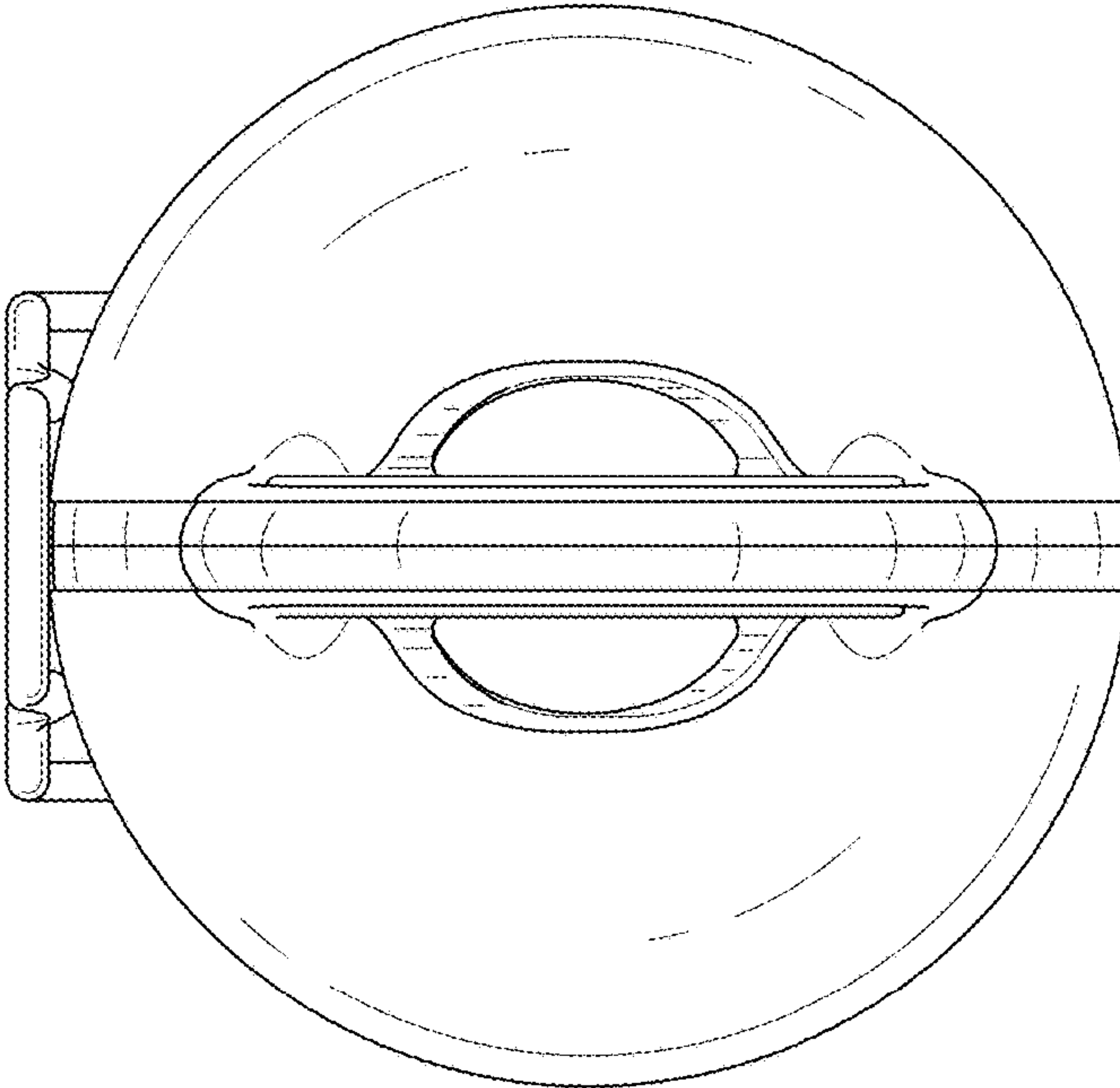

FIG. 3

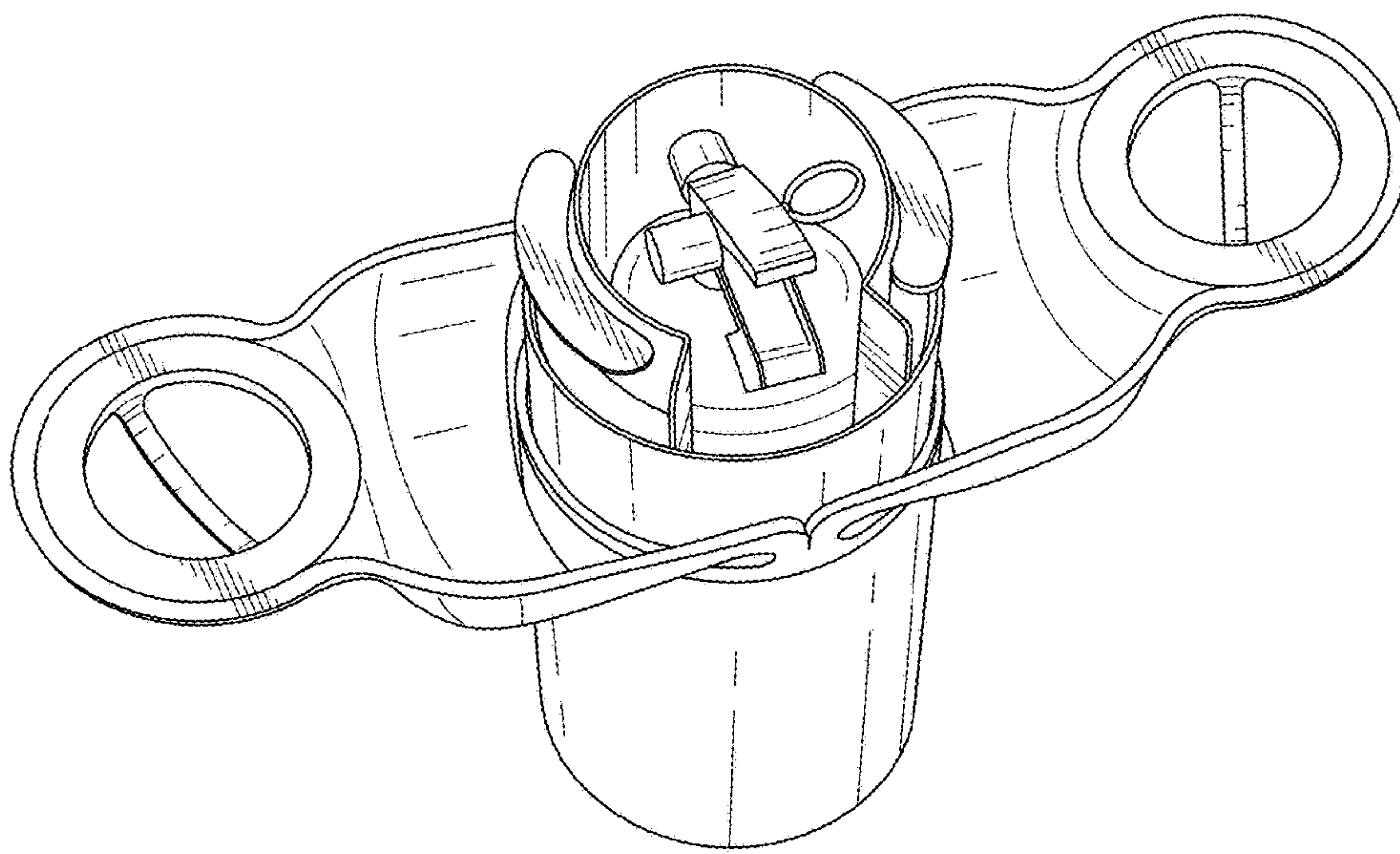

FIG. 4

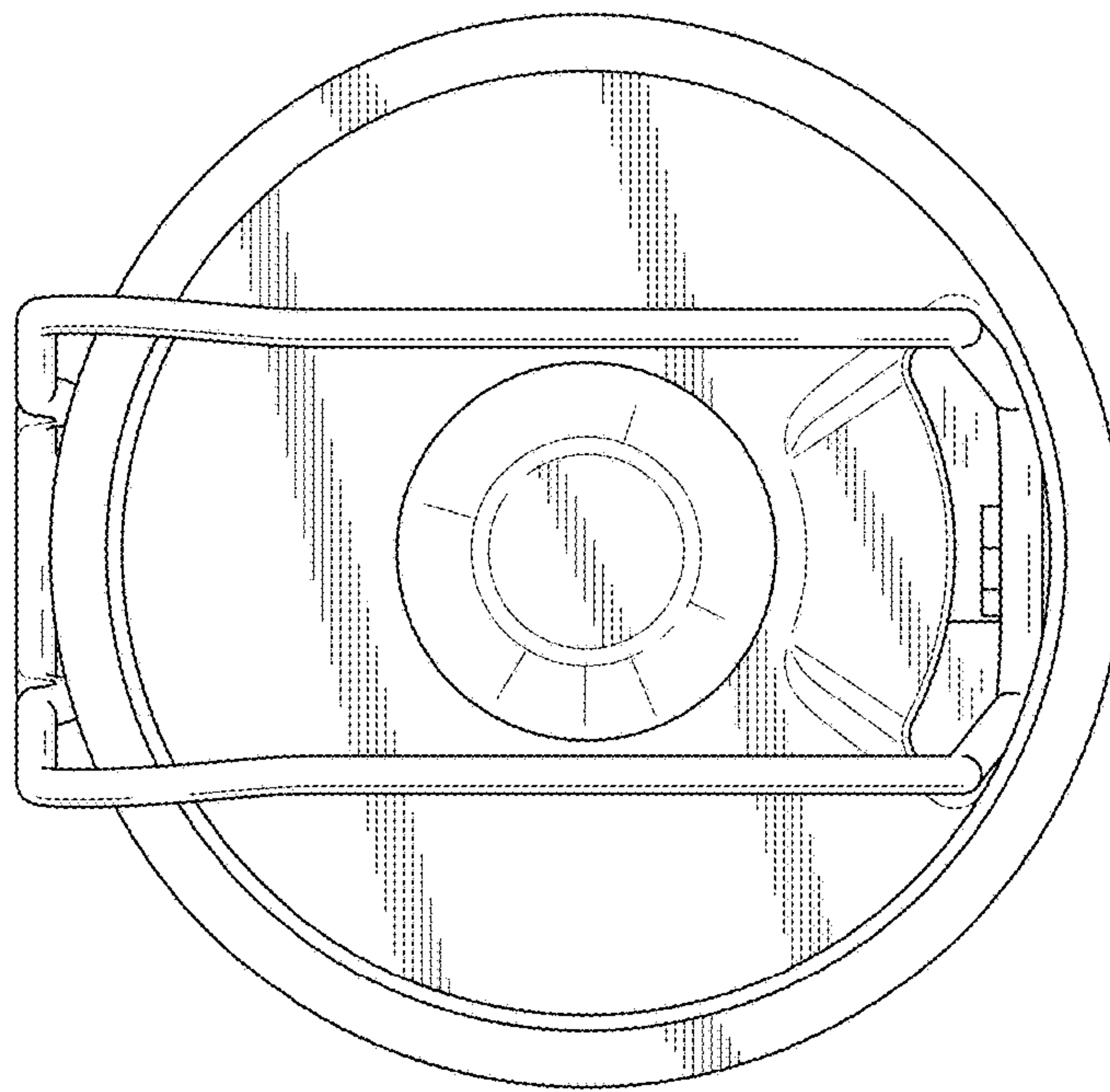

FIG. 5