



US00D852304S

(12) **United States Design Patent**
Parsons et al.

(10) **Patent No.:** **US D852,304 S**
(45) **Date of Patent:** **** Jun. 25, 2019**

- (54) **GOLF CLUB HEAD**
- (71) Applicant: **PARSONS XTREME GOLF, LLC**,
Scottsdale, AZ (US)
- (72) Inventors: **Robert R. Parsons**, Scottsdale, AZ
(US); **Bradley D. Schweigert**, Anthem,
AZ (US); **Michael R. Nicolette**,
Scottsdale, AZ (US)
- (73) Assignee: **PARSONS XTREME GOLF, LLC**,
Scottsdale, AZ (US)
- (**) Term: **15 Years**
- (21) Appl. No.: **29/661,161**
- (22) Filed: **Aug. 24, 2018**

| | | | | | | |
|-----------|---|---|---------|--------------------|-------|-----------------------|
| 1,534,600 | A | * | 4/1925 | Mattern | | A63B 53/08 473/337 |
| 1,538,312 | A | | 5/1925 | Beat | | |
| D94,549 | S | * | 2/1935 | Jansky | | D21/752 |
| D94,550 | S | * | 2/1935 | Jansky | | D21/752 |
| D138,437 | S | * | 8/1944 | Link | | D21/752 |
| D138,438 | S | | 8/1944 | Link | | |
| D138,439 | S | | 8/1944 | Link | | |
| D138,441 | S | * | 8/1944 | Link | | D21/752 |
| D138,442 | S | | 8/1944 | Link | | |
| D164,469 | S | | 9/1951 | Behrendt | | |
| D185,177 | S | | 5/1959 | Smith | | |
| 3,020,048 | A | | 2/1962 | Carroll | | |
| D203,936 | S | | 3/1966 | Long | | |
| D215,101 | S | | 9/1969 | Sabat | | |
| 3,556,553 | A | | 1/1971 | Kolbe | | |
| 3,652,094 | A | | 3/1972 | Glover | | |
| D229,431 | S | | 11/1973 | Baker | | |
| D234,609 | S | | 3/1975 | Raymont | | |
| D234,963 | S | | 4/1975 | Hirata | | |
| D239,550 | S | | 4/1976 | Timbrook | | |
| D240,054 | S | | 5/1976 | Meissler | | |
| D240,748 | S | | 7/1976 | Bock | | |
| 4,085,934 | A | | 4/1978 | Churchward | | |
| D253,778 | S | * | 12/1979 | Madison | | D21/752 |
| D261,167 | S | | 10/1981 | Swanson | | |
| 4,332,388 | A | | 6/1982 | Crow | | |
| D294,617 | S | | 3/1988 | Perkins | | |
| 4,754,977 | A | | 7/1988 | Sahm | | |
| 4,824,116 | A | | 4/1989 | Nagamoto et al. | | |
| D307,783 | S | | 5/1990 | Iinuma | | |
| 4,988,104 | A | | 1/1991 | Shiotani et al. | | |
| D326,885 | S | | 6/1992 | Paul | | |
| 5,158,296 | A | | 10/1992 | Lee | | |
| 5,176,384 | A | | 1/1993 | Sata et al. | | |
| 5,213,328 | A | | 5/1993 | Long et al. | | |
| 5,213,329 | A | | 5/1993 | Okumoto et al. | | |
| D336,672 | S | | 6/1993 | Gorman | | |
| D338,935 | S | * | 8/1993 | Antonious | | D21/733 |
| D344,561 | S | | 2/1994 | Gorman | | |
| D351,883 | S | * | 10/1994 | Solheim | | D21/752 |
| D353,862 | S | | 12/1994 | Saito | | |
| D357,520 | S | | 4/1995 | Helmstetter et al. | | |
| 5,419,560 | A | | 5/1995 | Bamber | | |
| 5,425,535 | A | | 6/1995 | Gee | | |
| D361,358 | S | | 8/1995 | Simmons | | |
| 5,447,311 | A | | 9/1995 | Viollaz et al. | | |
| 5,451,056 | A | | 9/1995 | Manning | | |
| D362,884 | S | | 10/1995 | Blough et al. | | |
| D362,885 | S | | 10/1995 | Blough et al. | | |
| D362,887 | S | | 10/1995 | Blough et al. | | |
| 5,518,243 | A | * | 5/1996 | Redman | | A63B 53/04 473/334 |

Related U.S. Application Data

- (63) Continuation-in-part of application No. 29/656,913, filed on Jul. 17, 2018, now abandoned, which is a continuation-in-part of application No. 29/646,582, filed on May 4, 2018, now abandoned, application No. 29/661,161, which is a continuation-in-part of application No. 29/646,576, filed on May 4, 2018, now abandoned, which is a continuation-in-part of application No. 29/645,048, filed on Apr. 23, 2018, now abandoned.
- (51) **LOC (11) Cl.** **21-02**
- (52) **U.S. Cl.**
USPC **D21/752**
- (58) **Field of Classification Search**
USPC D21/733, 752, 759
CPC A63B 53/00; A63B 53/04; A63B 53/0466;
A63B 2053/002; A63B 2053/0445; A63B
2053/0433; A63B 2053/0491; A63B
2053/0437; A63B 60/00; A63B 60/46
See application file for complete search history.

References Cited

U.S. PATENT DOCUMENTS

| | | | |
|-----------|---|--------|-----------|
| 1,133,129 | A | 3/1915 | Govan |
| 1,269,745 | A | 6/1918 | Robertson |
| 1,306,029 | A | 6/1919 | Robertson |
| D55,867 | S | 7/1920 | Mattern |

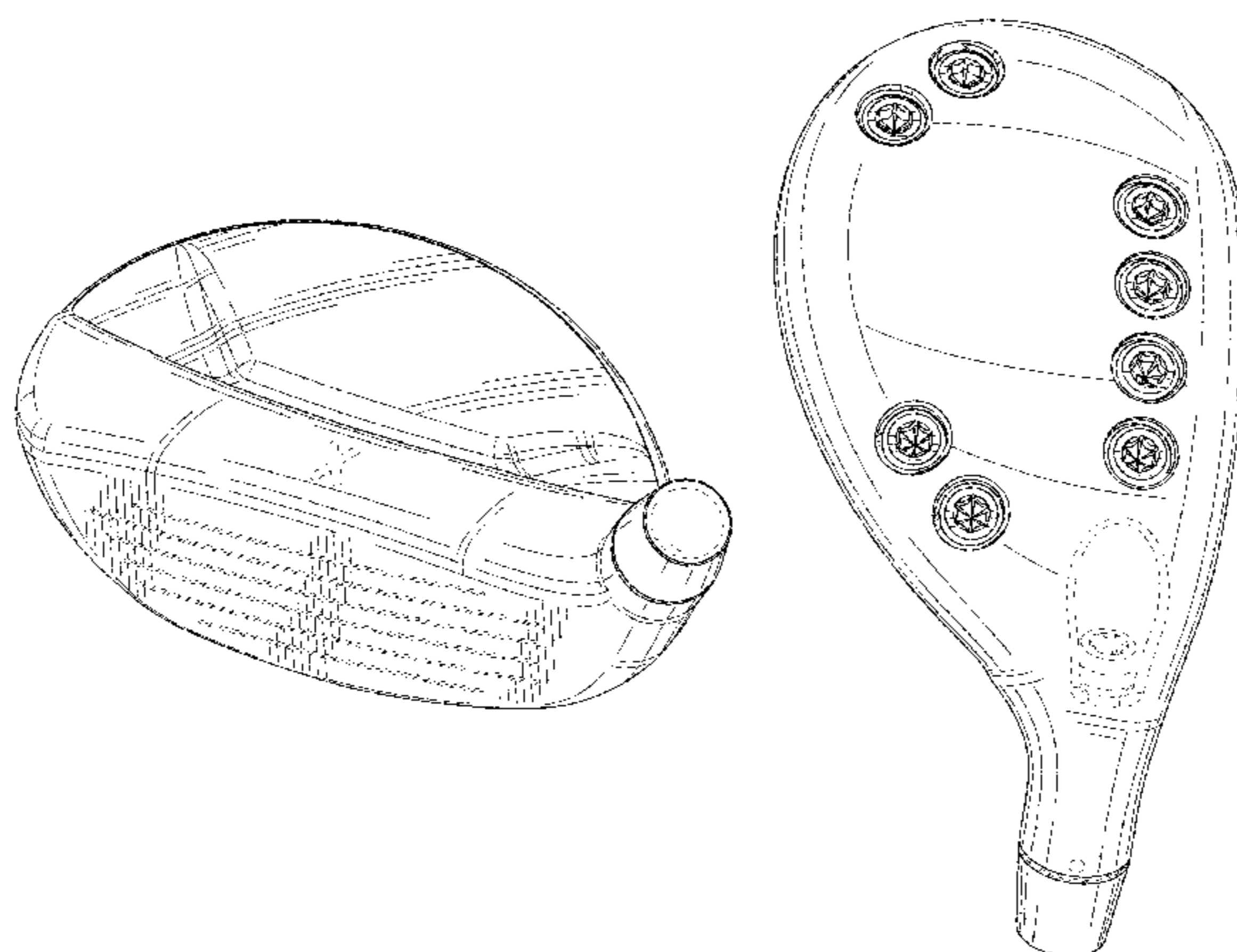

US D852,304 S

| | | | | | |
|---------------|---------|-------------------------------------|----------------|---------|--------------------------|
| D370,514 S | 6/1996 | Blough et al. | 7,166,040 B2 | 1/2007 | Hoffman et al. |
| D371,816 S | 7/1996 | Yoshioka | D536,401 S | 2/2007 | Kawami |
| 5,540,437 A | 7/1996 | Bamber | D536,403 S | 2/2007 | Kawami |
| D378,111 S * | 2/1997 | Parente D21/752 | D537,495 S | 2/2007 | Schweigert et al. |
| 5,637,045 A | 6/1997 | Igarashi | 7,182,698 B2 | 2/2007 | Tseng |
| D384,120 S * | 9/1997 | De La Cruz D21/752 | D538,363 S | 3/2007 | Schweigert et al. |
| 5,669,830 A | 9/1997 | Bamber | D538,371 S * | 3/2007 | Kawami D21/759 |
| D389,541 S | 1/1998 | Huan-Chiang | 7,186,190 B1 * | 3/2007 | Beach A63B 53/0466 |
| D395,476 S | 6/1998 | Pond et al. | | | 473/335 |
| 5,766,091 A | 6/1998 | Humphrey et al. | 7,207,900 B2 | 4/2007 | Nicolette et al. |
| 5,766,092 A | 6/1998 | Mimeur et al. | D543,601 S | 5/2007 | Kawami |
| 5,788,584 A * | 8/1998 | Parente A63B 53/04 473/290 | 7,223,180 B2 | 5/2007 | Willett |
| | | | D552,198 S | 10/2007 | Schweigert et al. |
| D399,277 S | 10/1998 | Ezaki | D555,219 S | 11/2007 | Lin |
| 5,827,132 A | 10/1998 | Bamber | D557,363 S | 12/2007 | Jertson et al. |
| D400,625 S | 11/1998 | Kubica et al. | D558,287 S | 12/2007 | Jertson et al. |
| D400,627 S | 11/1998 | Kubica et al. | D558,288 S | 12/2007 | Jertson et al. |
| D405,489 S | 2/1999 | Kubica et al. | 7,303,486 B2 | 12/2007 | Imamoto |
| D405,492 S | 2/1999 | Kubica et al. | D559,932 S | 1/2008 | Belmont |
| D408,485 S | 4/1999 | Takahashi et al. | D560,262 S | 1/2008 | Ngyuyen et al. |
| 5,899,821 A | 5/1999 | Hsu et al. | D561,284 S * | 2/2008 | Nagai D21/759 |
| 5,935,016 A | 8/1999 | Antonious | D562,421 S | 2/2008 | Jertson et al. |
| D414,535 S | 9/1999 | Mertens | D563,498 S | 3/2008 | Jertson et al. |
| D421,080 S | 2/2000 | Chen | D564,054 S | 3/2008 | Jertson et al. |
| D426,276 S | 6/2000 | Besnard et al. | D564,055 S | 3/2008 | Jertson et al. |
| 6,077,171 A | 6/2000 | Yoneyama | 7,338,388 B2 | 3/2008 | Schweigert et al. |
| D442,659 S | 5/2001 | Kubica et al. | 7,347,794 B2 | 3/2008 | Schweigert |
| D443,008 S | 5/2001 | Kubica et al. | D567,317 S | 4/2008 | Jertson et al. |
| D444,830 S | 7/2001 | Kubica et al. | 7,351,164 B2 | 4/2008 | Schweigert et al. |
| D445,862 S | 7/2001 | Ford | D569,933 S | 5/2008 | Jertson et al. |
| 6,290,609 B1 | 9/2001 | Takeda | D569,934 S | 5/2008 | Jertson et al. |
| D448,824 S | 10/2001 | Koizumi et al. | D569,935 S | 5/2008 | Schweigert et al. |
| D449,866 S | 10/2001 | Miller | D569,936 S | 5/2008 | Schweigert et al. |
| D457,211 S | 5/2002 | Bakke | D569,942 S | 5/2008 | Jertson et al. |
| D469,833 S | 2/2003 | Roberts et al. | D570,937 S | 6/2008 | Schweigert et al. |
| D473,604 S * | 4/2003 | Antonious D21/733 | D570,938 S | 6/2008 | Jertson et al. |
| D473,605 S | 4/2003 | Petersen et al. | 7,396,299 B2 | 7/2008 | Nicolette et al. |
| D475,107 S | 5/2003 | Madore | 7,407,447 B2 | 8/2008 | Beach et al. |
| D476,048 S | 6/2003 | Cleveland et al. | 7,410,425 B2 | 8/2008 | Willett et al. |
| D478,140 S | 8/2003 | Burrows | 7,410,426 B2 | 8/2008 | Willett et al. |
| D478,949 S | 8/2003 | DeLaCruz | 7,419,441 B2 | 9/2008 | Hoffman et al. |
| D481,087 S * | 10/2003 | Antonious D21/733 | 7,448,963 B2 | 11/2008 | Beach et al. |
| 6,638,182 B2 | 10/2003 | Kosmatka | 7,448,964 B2 | 11/2008 | Schweigert et al. |
| 6,695,714 B1 | 2/2004 | Bliss et al. | D584,370 S | 1/2009 | Cleveland et al. |
| 6,702,693 B2 | 3/2004 | Bamber | 7,530,904 B2 | 5/2009 | Beach et al. |
| 6,773,360 B2 | 8/2004 | Willett et al. | D594,518 S | 6/2009 | Schweigert |
| 6,780,123 B2 | 8/2004 | Hasebe | D594,520 S | 6/2009 | Schweigert et al. |
| D497,963 S | 11/2004 | Toulon et al. | D594,521 S | 6/2009 | Jertson et al. |
| 6,811,496 B2 | 11/2004 | Wahl et al. | D594,919 S | 6/2009 | Schweigert et al. |
| D499,779 S | 12/2004 | Mahaffey et al. | 7,540,811 B2 | 6/2009 | Beach et al. |
| D502,975 S | 3/2005 | Schweigert et al. | D597,620 S | 8/2009 | Taylor et al. |
| D503,204 S | 3/2005 | Nicolette et al. | 7,568,985 B2 | 8/2009 | Beach et al. |
| D507,320 S | 7/2005 | Roberts et al. | 7,578,753 B2 | 8/2009 | Beach et al. |
| D508,545 S | 8/2005 | Roberts et al. | D600,297 S | 9/2009 | Jertson et al. |
| D508,969 S | 8/2005 | Hasebe | 7,584,531 B2 | 9/2009 | Schweigert et al. |
| 6,923,733 B2 | 8/2005 | Chen | 7,588,502 B2 | 9/2009 | Nishino |
| 6,939,247 B1 | 9/2005 | Schweigert et al. | 7,591,738 B2 | 9/2009 | Beach et al. |
| D513,051 S | 12/2005 | Barez et al. | D603,472 S | 11/2009 | Schweigert et al. |
| D514,179 S | 1/2006 | Chen et al. | D604,783 S | 11/2009 | Nicolette et al. |
| D514,183 S | 1/2006 | Schweigert et al. | 7,611,424 B2 | 11/2009 | Nagai et al. |
| D514,185 S | 1/2006 | Barez et al. | 7,621,823 B2 | 11/2009 | Beach et al. |
| D515,642 S * | 2/2006 | Antonious D21/733 | D605,715 S | 12/2009 | Barez et al. |
| D516,650 S | 3/2006 | Wolfe et al. | D606,605 S | 12/2009 | Wada et al. |
| D518,863 S | 4/2006 | Motoyoshi et al. | D607,070 S | 12/2009 | Wada et al. |
| D520,585 S | 5/2006 | Hasebe | D607,071 S | 12/2009 | Wada et al. |
| D520,586 S | 5/2006 | Bingman | 7,632,194 B2 | 12/2009 | Beach |
| D522,077 S | 5/2006 | Schweigert et al. | 7,658,686 B2 | 2/2010 | Soracco |
| D522,601 S | 6/2006 | Schweigert et al. | D612,438 S | 3/2010 | Carlyle et al. |
| D523,104 S | 6/2006 | Hasebe | D612,439 S | 3/2010 | Carlyle et al. |
| D523,498 S | 6/2006 | Chen et al. | 7,713,142 B2 | 5/2010 | Hoffman et al. |
| D523,501 S | 6/2006 | Nicolette et al. | 7,717,804 B2 | 5/2010 | Beach et al. |
| D523,917 S | 6/2006 | Wolfe et al. | 7,717,805 B2 | 5/2010 | Beach et al. |
| D524,889 S | 7/2006 | Yu et al. | D617,406 S | 6/2010 | Carlyle et al. |
| D526,694 S | 8/2006 | Schweigert et al. | D618,293 S | 6/2010 | Foster et al. |
| 7,121,956 B2 | 10/2006 | Lo | D618,746 S | 6/2010 | Jertson et al. |
| 7,128,663 B2 | 10/2006 | Bamber | D618,747 S | 6/2010 | Schweigert et al. |
| D534,595 S | 1/2007 | Hasebe | D618,753 S | 6/2010 | Jertson et al. |
| D534,599 S | 1/2007 | Barez et al. | D618,754 S | 6/2010 | Schweigert et al. |
| 7,156,751 B2 | 1/2007 | Wahl et al. | | | |

US D852,304 S

| | | | | | | | |
|----------------|---------|-------------------|-------------------------|-------------------|---------|-------------------|-------------------------|
| 7,744,484 B1 * | 6/2010 | Chao | A63B 53/0466 473/324 | D726,265 S | 4/2015 | Nicolette | |
| D621,893 S | 8/2010 | Nicolette et al. | | D726,846 S | 4/2015 | Schweigert | |
| 7,798,203 B2 | 9/2010 | Schweigert et al. | | D729,892 S * | 5/2015 | Nicolette | D21/752 |
| 7,798,917 B2 | 9/2010 | Nguyen et al. | | D733,234 S * | 6/2015 | Nicolette | D21/752 |
| 7,815,521 B2 | 10/2010 | Ban | | D738,449 S | 9/2015 | Schweigert | |
| 7,846,040 B2 | 12/2010 | Ban | | D739,487 S | 9/2015 | Schweigert | |
| 7,846,041 B2 | 12/2010 | Beach et al. | | 9,199,140 B1 * | 12/2015 | Schweigert | A63B 53/0466 |
| D633,967 S | 3/2011 | Carlyle et al. | | 9,199,143 B1 | 12/2015 | Parsons et al. | |
| D635,626 S | 4/2011 | Nicolette | | D746,927 S * | 1/2016 | Parsons | D21/752 |
| 7,927,229 B2 | 4/2011 | Jertson et al. | | D748,214 S | 1/2016 | Nicolette et al. | |
| D638,893 S | 5/2011 | Schweigert et al. | | D748,215 S | 1/2016 | Parsons et al. | |
| D638,896 S | 5/2011 | Schweigert et al. | | D748,749 S | 2/2016 | Nicolette et al. | |
| 7,938,738 B2 | 5/2011 | Roach | | D753,251 S * | 4/2016 | Schweigert | D21/759 |
| 7,963,861 B2 | 6/2011 | Beach et al. | | D753,252 S | 4/2016 | Schweigert | |
| D643,490 S | 8/2011 | Wada et al. | | D755,319 S * | 5/2016 | Nicolette | D21/759 |
| 8,012,038 B1 | 9/2011 | Beach et al. | | D756,471 S | 5/2016 | Nicolette et al. | |
| D647,585 S | 10/2011 | Jertson et al. | | 9,352,197 B2 * | 5/2016 | Parsons | A63B 53/0466 |
| 8,062,150 B2 | 11/2011 | Gilbert et al. | | D759,178 S * | 6/2016 | Nicolette | D21/759 |
| 8,088,025 B2 | 1/2012 | Wahl et al. | | D760,334 S * | 6/2016 | Schweigert | D21/752 |
| 8,092,319 B1 | 1/2012 | Cackett et al. | | 9,399,158 B2 * | 7/2016 | Parsons | A63B 53/047 |
| 8,105,180 B1 | 1/2012 | Cackett et al. | | D764,614 S | 8/2016 | Parsons et al. | |
| D658,248 S | 4/2012 | Nunez et al. | | 9,421,437 B2 | 8/2016 | Parsons et al. | |
| D661,751 S | 6/2012 | Nicolette et al. | | 9,427,634 B2 | 8/2016 | Parsons et al. | |
| D661,756 S | 6/2012 | Nicolette et al. | | D767,696 S * | 9/2016 | Parsons | D21/752 |
| 8,221,262 B1 | 7/2012 | Cackett et al. | | D776,216 S * | 1/2017 | Schweigert | D21/752 |
| 8,246,487 B1 | 8/2012 | Cackett et al. | | D777,858 S * | 1/2017 | Schweigert | D21/752 |
| 8,257,196 B1 * | 9/2012 | Abbott | A63B 53/0466 473/335 | 9,555,295 B2 * | 1/2017 | Schweigert | A63B 53/0466 |
| 8,257,197 B2 | 9/2012 | Schweigert | | 9,630,070 B2 * | 4/2017 | Parsons | A63B 53/0466 |
| 8,262,506 B2 * | 9/2012 | Watson | A63B 53/0466 473/334 | D802,069 S * | 11/2017 | Parsons | D21/752 |
| 8,328,662 B2 | 12/2012 | Nakamura et al. | | D802,070 S * | 11/2017 | Parsons | D21/752 |
| D673,630 S | 1/2013 | Schweigert | | D807,976 S * | 1/2018 | Parsons | D21/752 |
| D673,632 S | 1/2013 | Schweigert et al. | | D827,067 S * | 8/2018 | Becktor | D21/752 |
| 8,371,957 B2 | 2/2013 | Schweigert et al. | | D827,745 S * | 9/2018 | Schweigert | D21/752 |
| 8,376,878 B2 | 2/2013 | Bennett et al. | | 2002/0107087 A1 | 8/2002 | Fagot | |
| D680,179 S | 4/2013 | Solheim et al. | | 2003/0139226 A1 | 7/2003 | Cheng et al. | |
| D681,142 S | 4/2013 | Fossum et al. | | 2003/0176231 A1 | 9/2003 | Hasebe | |
| 8,414,422 B2 | 4/2013 | Peralta et al. | | 2004/0204263 A1 | 10/2004 | Fagot et al. | |
| 8,485,919 B2 * | 7/2013 | Rice | A63B 53/0466 473/334 | 2005/0009632 A1 | 1/2005 | Schweigert et al. | |
| 8,506,420 B2 | 8/2013 | Hocknell et al. | | 2005/0014573 A1 | 1/2005 | Lee | |
| D689,156 S | 9/2013 | Stokke et al. | | 2005/0119066 A1 | 6/2005 | Stites et al. | |
| D691,230 S | 10/2013 | Chen et al. | | 2005/0239569 A1 | 10/2005 | Best et al. | |
| 8,545,343 B2 | 10/2013 | Boyd et al. | | 2005/0277485 A1 | 12/2005 | Hou et al. | |
| 8,562,457 B2 | 10/2013 | Beach et al. | | 2006/0105856 A1 * | 5/2006 | Lo | A63B 53/04 473/334 |
| 8,574,094 B2 | 11/2013 | Nicolette et al. | | 2006/0111200 A1 | 5/2006 | Poynor | |
| 8,608,587 B2 | 12/2013 | Henrikson et al. | | 2007/0032308 A1 | 2/2007 | Fagot et al. | |
| 8,628,431 B2 | 1/2014 | Schweigert et al. | | 2007/0225084 A1 | 9/2007 | Schweigert et al. | |
| 8,657,700 B2 | 2/2014 | Nicolette et al. | | 2007/0293344 A1 | 12/2007 | Davis | |
| 8,663,026 B2 | 3/2014 | Blowers et al. | | 2008/0004133 A1 | 1/2008 | Schweigert | |
| 8,690,710 B2 | 4/2014 | Nicolette et al. | | 2008/0058113 A1 | 3/2008 | Nicolette et al. | |
| D707,316 S | 6/2014 | Aguayo et al. | | 2008/0188322 A1 | 8/2008 | Anderson et al. | |
| D707,317 S | 6/2014 | Aguayo et al. | | 2008/0300065 A1 | 12/2008 | Schweigert | |
| 8,753,230 B2 | 6/2014 | Stokke et al. | | 2009/0029790 A1 | 1/2009 | Nicolette et al. | |
| 8,777,778 B2 | 7/2014 | Solheim et al. | | 2009/0029795 A1 | 1/2009 | Schweigert et al. | |
| 8,784,232 B2 | 7/2014 | Jertson et al. | | 2010/0130306 A1 | 5/2010 | Schweigert | |
| 8,790,196 B2 | 7/2014 | Solheim et al. | | 2010/0144461 A1 * | 6/2010 | Ban | A63B 53/0466 473/338 |
| 8,808,108 B2 | 8/2014 | Schweigert | | 2010/0178999 A1 | 7/2010 | Nicolette et al. | |
| D712,989 S * | 9/2014 | Gillig | D21/752 | 2011/0111883 A1 | 5/2011 | Cackett | |
| 8,826,512 B2 | 9/2014 | Schweigert | | 2011/0143858 A1 * | 6/2011 | Peralta | A63B 53/0466 473/335 |
| 8,827,832 B2 | 9/2014 | Breier et al. | | 2011/0165963 A1 | 7/2011 | Cackett et al. | |
| 8,827,833 B2 | 9/2014 | Amano et al. | | 2011/0269567 A1 | 11/2011 | Ban et al. | |
| 8,845,455 B2 | 9/2014 | Ban et al. | | 2011/0294596 A1 | 12/2011 | Ban | |
| D714,894 S * | 10/2014 | Tang | D21/759 | 2012/0202615 A1 * | 8/2012 | Beach | A63B 53/0466 473/338 |
| D716,387 S | 10/2014 | Aguayo et al. | | 2013/0137532 A1 | 5/2013 | Deshmukh et al. | |
| D716,388 S | 10/2014 | Aguayo et al. | | 2013/0225319 A1 | 8/2013 | Kato | |
| 8,858,362 B1 * | 10/2014 | Leposky | A63B 60/02 473/334 | 2013/0281226 A1 | 10/2013 | Ban | |
| D721,544 S | 1/2015 | Hollander | | 2013/0288823 A1 | 10/2013 | Hebreo | |
| D722,351 S | 2/2015 | Parsons et al. | | 2013/0303303 A1 | 11/2013 | Ban | |
| D722,352 S | 2/2015 | Nicolette et al. | | 2013/0303304 A1 | 11/2013 | Sato | |
| D723,120 S | 2/2015 | Nicolette | | 2013/0310192 A1 | 11/2013 | Wahl et al. | |
| 8,961,336 B1 | 2/2015 | Parsons et al. | | 2014/0080621 A1 | 3/2014 | Nicolette et al. | |
| D724,164 S * | 3/2015 | Schweigert | D21/752 | 2014/0128175 A1 | 5/2014 | Jertson et al. | |
| D725,208 S | 3/2015 | Schweigert | | 2014/0274441 A1 | 9/2014 | Greer | |
| 8,979,671 B1 * | 3/2015 | DeMille | A63B 53/0466 473/334 | 2014/0274451 A1 | 9/2014 | Knight | |
| | | | | 2015/0231454 A1 | 8/2015 | Parsons et al. | |
| | | | | 2015/0231806 A1 | 8/2015 | Parsons et al. | |

OTHER PUBLICATIONS

International Search Report and Written Opinion issued in connection with corresponding application No. PCT/US2015/016666, dated May 14, 2015 (8 pages).

International Search Report and Written Opinion received in connection with PCT/US15/42484 dated Oct. 19, 2015 (12 pages).

International Search Report and Written Opinion received in connection with PCT Application PCTUS2015042282 dated Oct. 13, 2015 (12 pages).

Kozuchowski, Zak, "Callaway Mack Daddy 2 PM Grind Wedges" (<http://www.golfwrx.com/276203/callaway-mack-daddy-2-pm-grind-wedges/>), www.golfwrx.com, GolfWRX Holdings, LLC, published Jan. 21, 2015.

Wall, Jonathan, "Details: Phil's Prototype Mack Daddy PM-Grind Wedge," (<http://www.pgatour.com/equipmentreport/2015/01/21/callaway-wedge.html>), www.pgatour.com, PGA Tour, Inc., published Jan. 21, 2015.

U.S. Appl. No. 29/512,313, Nicolette, "Golf Club Head," filed Dec. 18, 2014.

* cited by examiner

Primary Examiner — Mitchell I. Siegel

(57) CLAIM

The ornamental design for a golf club head, as shown and described.

DESCRIPTION

FIG. 1 is a top perspective view of a golf club head;
 FIG. 2 is a bottom perspective view of the golf club head of FIG. 1;
 FIG. 3 is a front elevational view of the golf club head of FIG. 1;
 FIG. 4 is a rear elevational view of the golf club head of FIG. 1;
 FIG. 5 is a top view of the golf club head of FIG. 1;
 FIG. 6 is a bottom view of the golf club head of FIG. 1;
 FIG. 7 is a left side view of the golf club head of FIG. 1;
 FIG. 8 is a right side view of the golf club head of FIG. 1;
 FIG. 9 is a top perspective view of a second embodiment of a golf club head;
 FIG. 10 is a bottom perspective view of the golf club head of FIG. 9;
 FIG. 11 is a front elevational view of the golf club head of FIG. 9;
 FIG. 12 is a rear elevational view of the golf club head of FIG. 9;
 FIG. 13 is a top view of the golf club head of FIG. 9;
 FIG. 14 is a bottom view of the golf club head of FIG. 9;
 FIG. 15 is a left side view of the golf club head of FIG. 9;
 FIG. 16 is a right side view of the golf club head of FIG. 9;
 FIG. 17 is a top perspective view of a third embodiment of a golf club head;
 FIG. 18 is a bottom perspective view of the golf club head of FIG. 17;
 FIG. 19 is a front elevational view of the golf club head of FIG. 17;
 FIG. 20 is a rear elevational view of the golf club head of FIG. 17;
 FIG. 21 is a top view of the golf club head of FIG. 17;
 FIG. 22 is a bottom view of the golf club head of FIG. 17;
 FIG. 23 is a left side view of the golf club head of FIG. 17;
 FIG. 24 is a right side view of the golf club head of FIG. 17;

FIG. 25 is a top perspective view of a fourth embodiment of a golf club head;
 FIG. 26 is a bottom perspective view of the golf club head of FIG. 25;
 FIG. 27 is a front elevational view of the golf club head of FIG. 25;
 FIG. 28 is a rear elevational view of the golf club head of FIG. 25;
 FIG. 29 is a top view of the golf club head of FIG. 25;
 FIG. 30 is a bottom view of the golf club head of FIG. 25;
 FIG. 31 is a left side view of the golf club head of FIG. 25;
 FIG. 32 is a right side view of the golf club head of FIG. 25;
 FIG. 33 is a top perspective view of a fifth embodiment of a golf club head;
 FIG. 34 is a bottom perspective view of the golf club head of FIG. 33;
 FIG. 35 is a front elevational view of the golf club head of FIG. 33;
 FIG. 36 is a rear elevational view of the golf club head of FIG. 33;
 FIG. 37 is a top view of the golf club head of FIG. 33;
 FIG. 38 is a bottom view of the golf club head of FIG. 33;
 FIG. 39 is a left side view of the golf club head of FIG. 33;
 FIG. 40 is a right side view of the golf club head of FIG. 33;
 FIG. 41 is a top perspective view of a sixth embodiment of a golf club head;
 FIG. 42 is a bottom perspective view of the golf club head of FIG. 41;
 FIG. 43 is a front elevational view of the golf club head of FIG. 41;
 FIG. 44 is a rear elevational view of the golf club head of FIG. 41;
 FIG. 45 is a top view of the golf club head of FIG. 41;
 FIG. 46 is a bottom view of the golf club head of FIG. 41;
 FIG. 47 is a left side view of the golf club head of FIG. 41;
 FIG. 48 is a right side view of the golf club head of FIG. 41;
 FIG. 49 is a top perspective view of a seventh embodiment of a golf club head;
 FIG. 50 is a bottom perspective view of the golf club head of FIG. 49;
 FIG. 51 is a front elevational view of the golf club head of FIG. 49;
 FIG. 52 is a rear elevational view of the golf club head of FIG. 49;
 FIG. 53 is a top view of the golf club head of FIG. 49;
 FIG. 54 is a bottom view of the golf club head of FIG. 49;
 FIG. 55 is a left side view of the golf club head of FIG. 49;
 FIG. 56 is a right side view of the golf club head of FIG. 49;
 FIG. 57 is a top perspective view of an eighth embodiment of a golf club head;
 FIG. 58 is a bottom perspective view of the golf club head of FIG. 57;
 FIG. 59 is a front elevational view of the golf club head of FIG. 57;
 FIG. 60 is a rear elevational view of the golf club head of FIG. 57;
 FIG. 61 is a top view of the golf club head of FIG. 57;
 FIG. 62 is a bottom view of the golf club head of FIG. 57;
 FIG. 63 is a left side view of the golf club head of FIG. 57;
 and,
 FIG. 64 is a right side view of the golf club head of FIG. 57.
 The broken line showing is included for the purpose of illustrating unclaimed subject matter and forms no part of the claimed design.

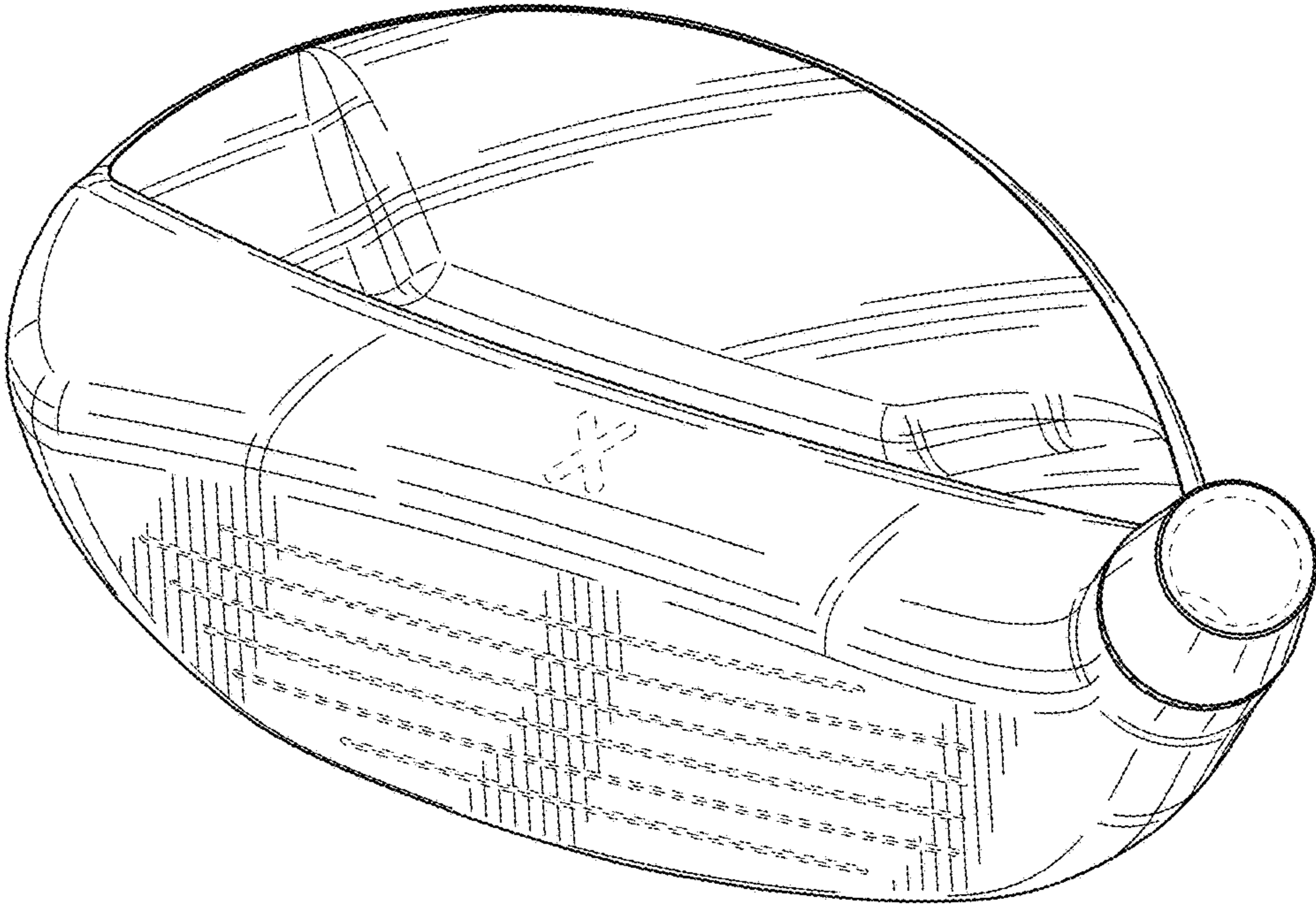

FIG. 1

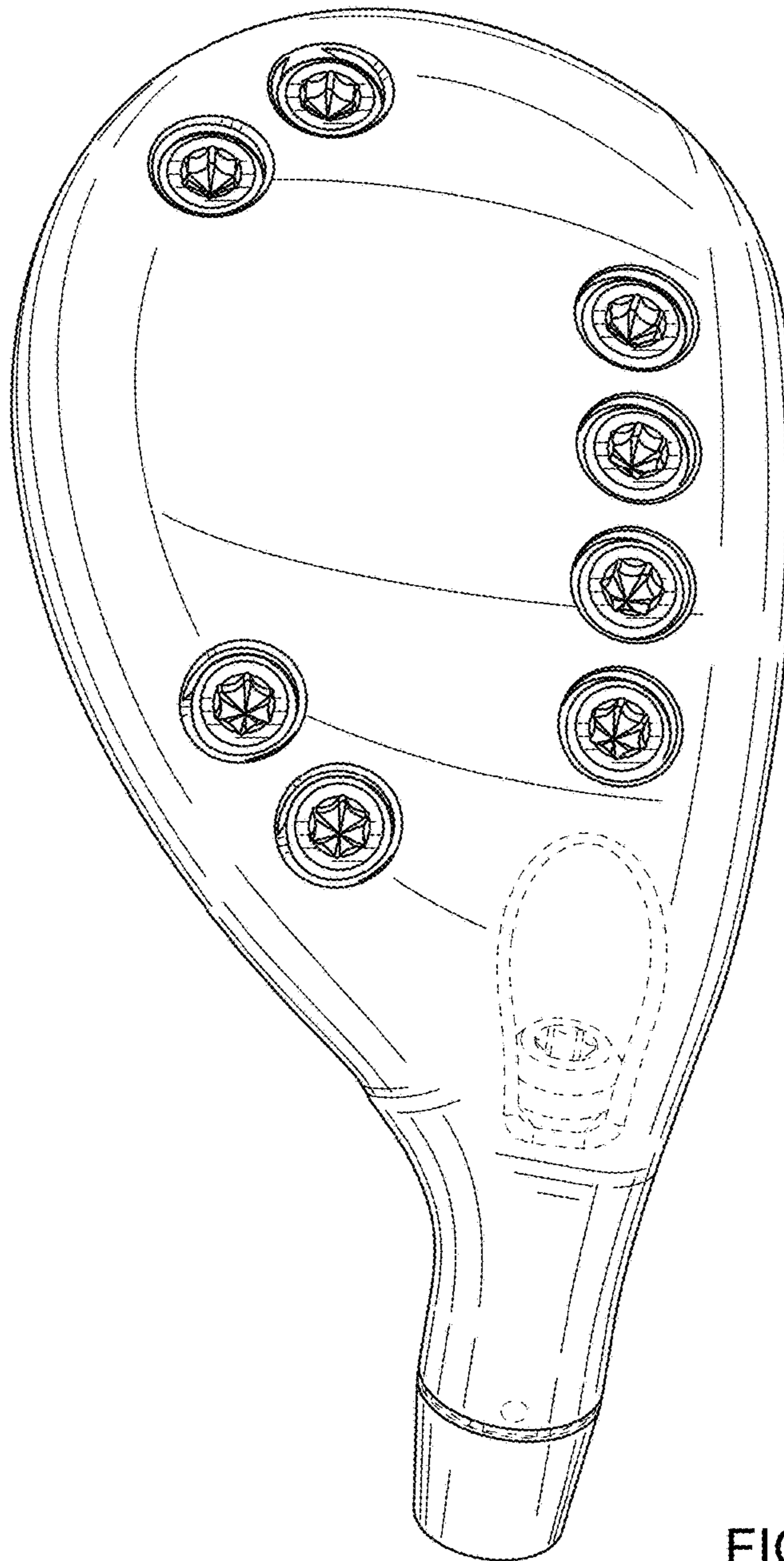

FIG. 2

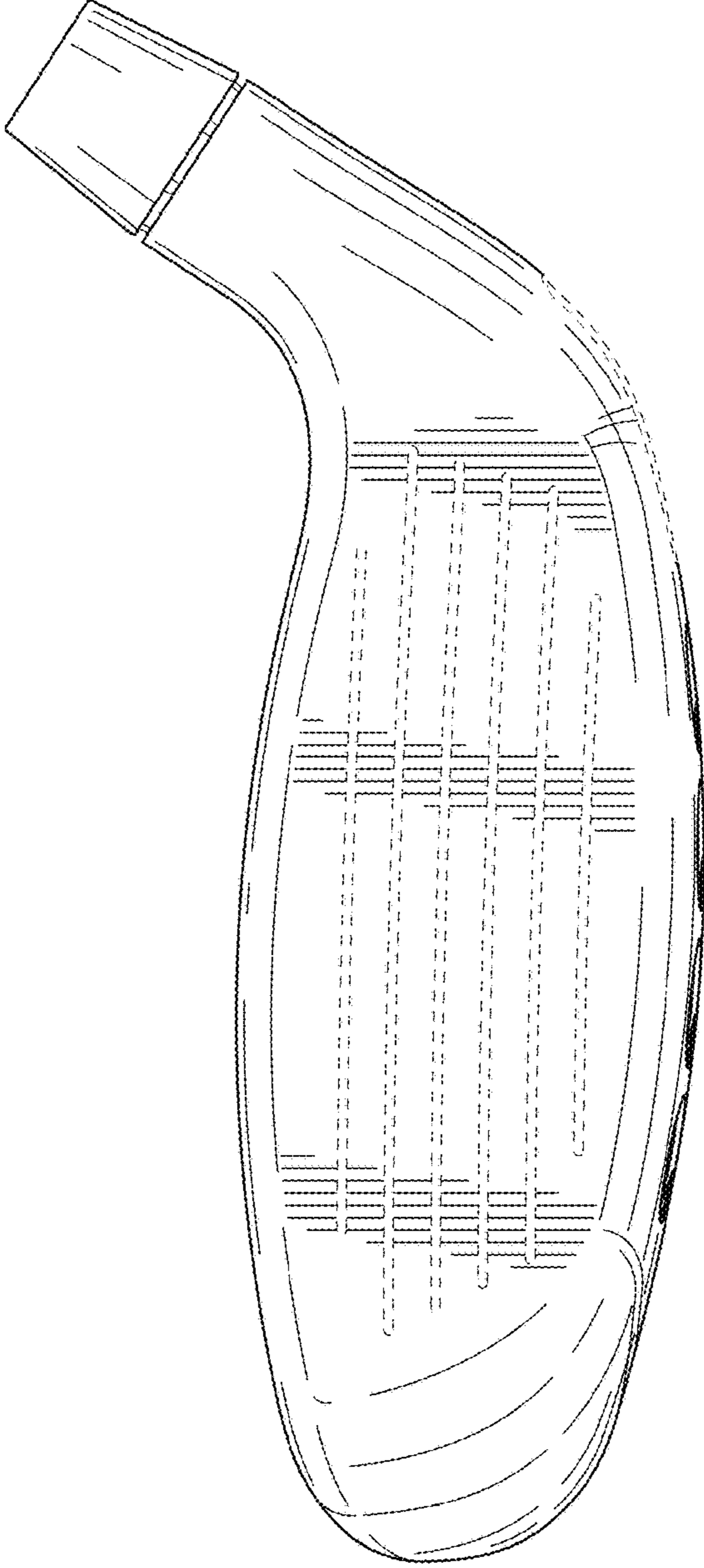

FIG. 3



FIG. 4

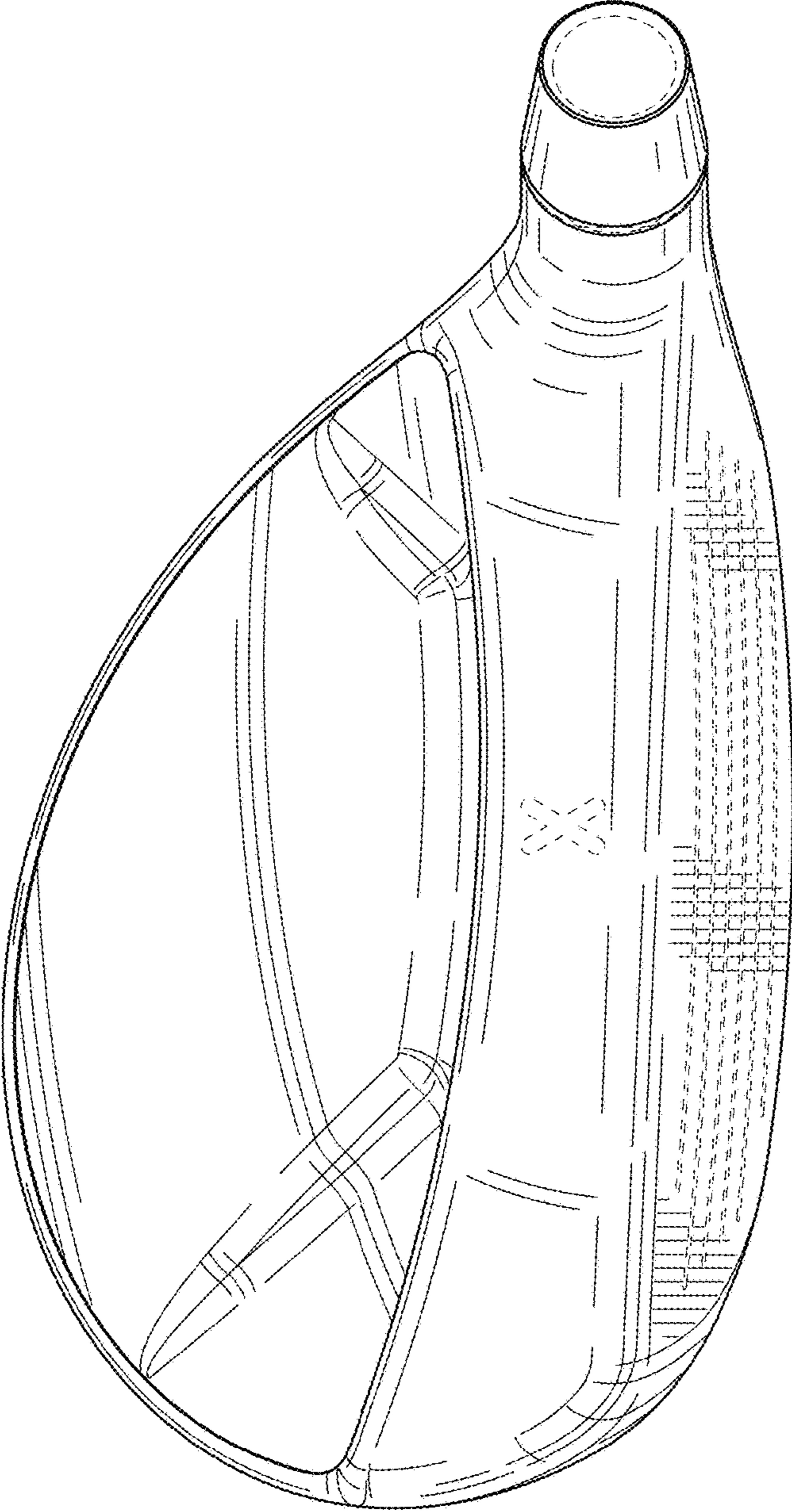

FIG. 5

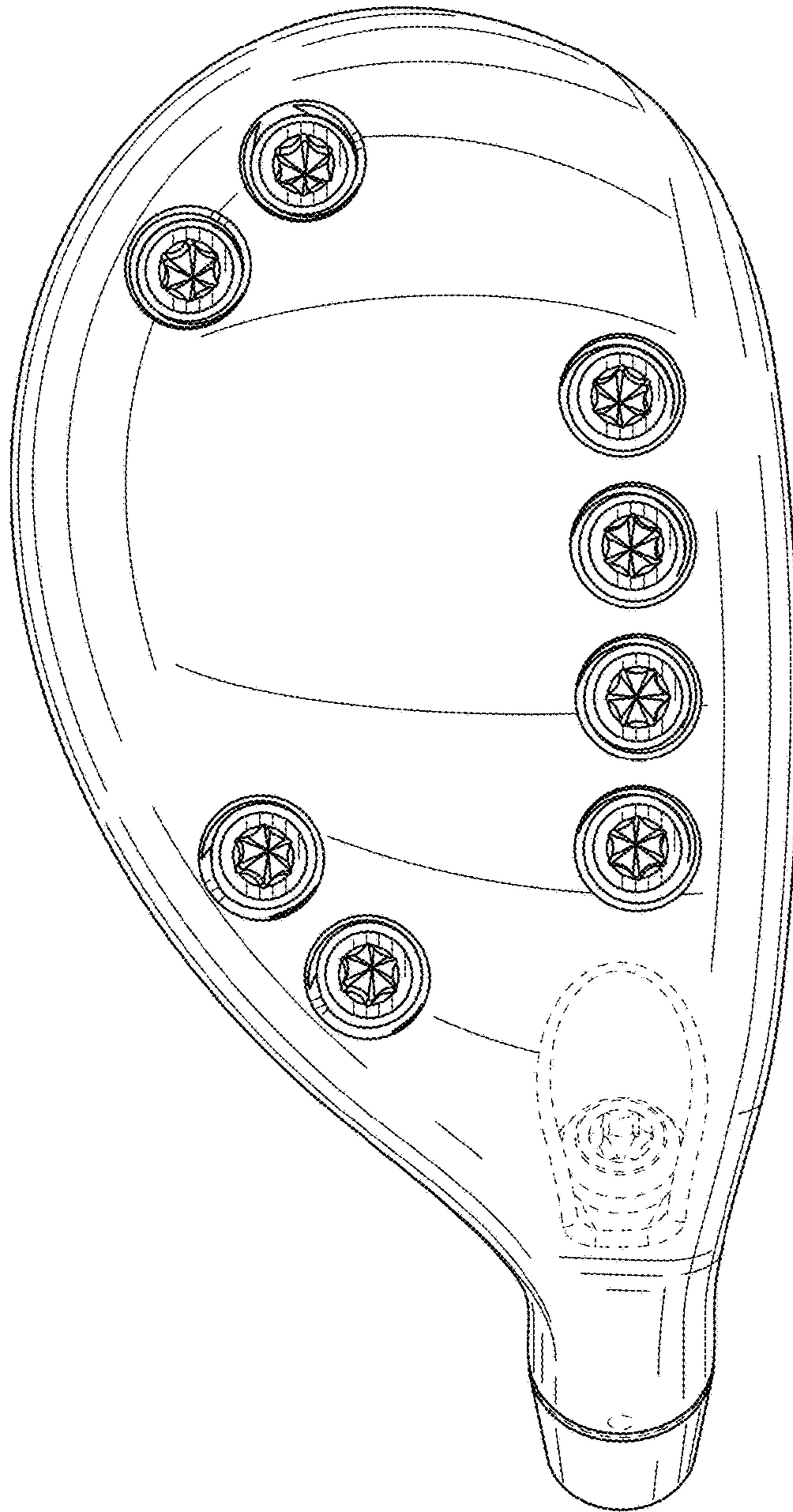

FIG. 6

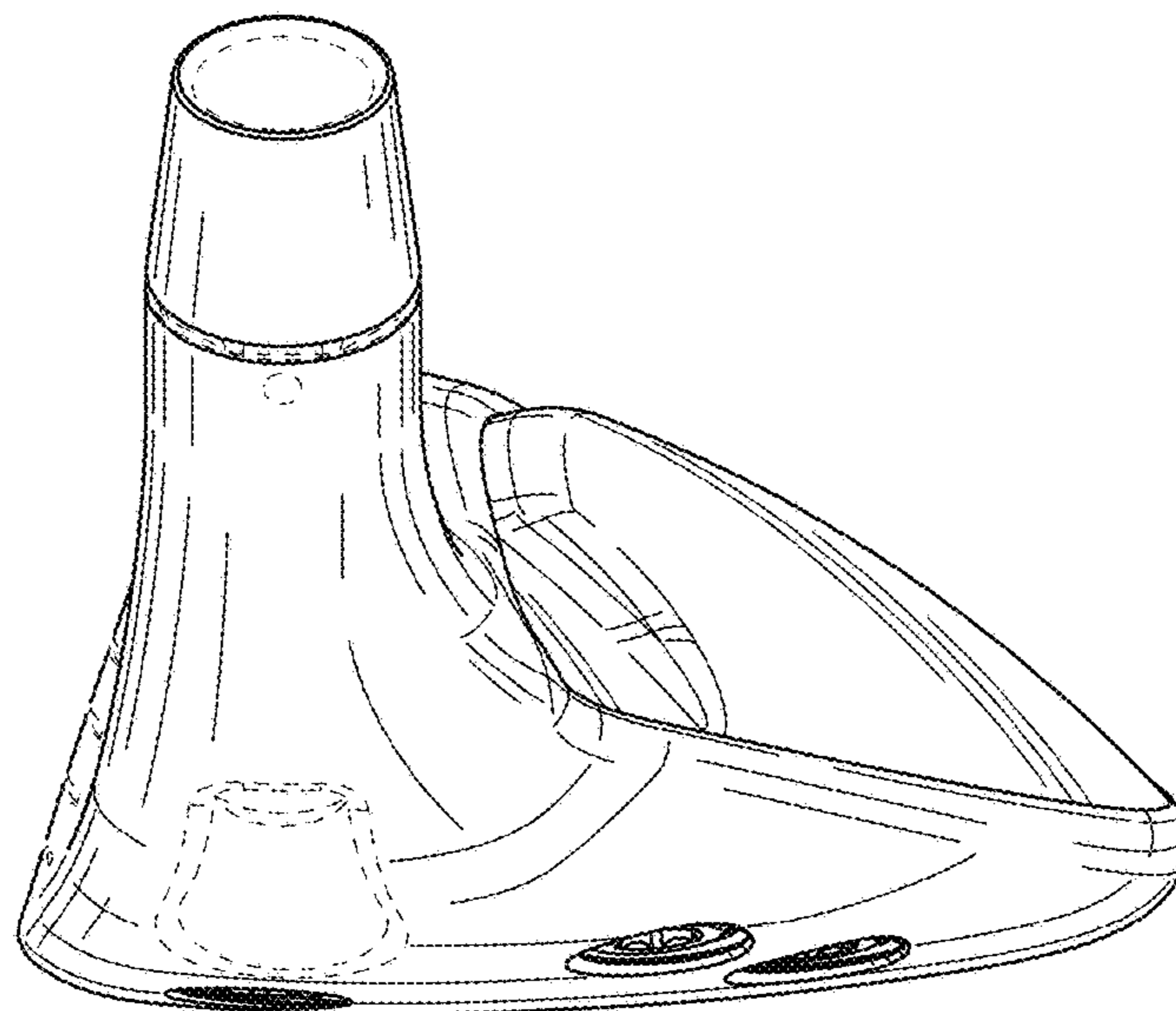

FIG. 7

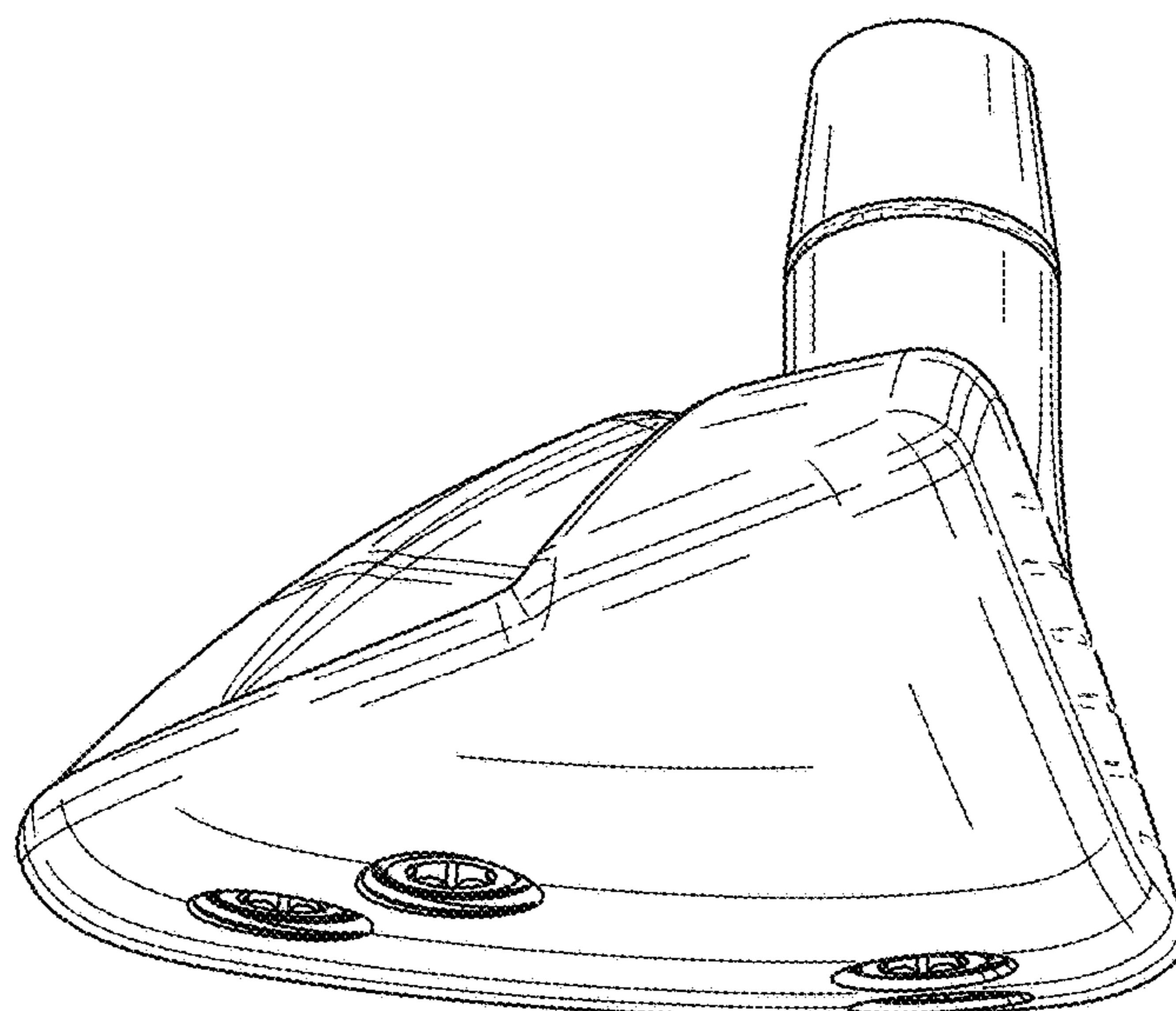

FIG. 8

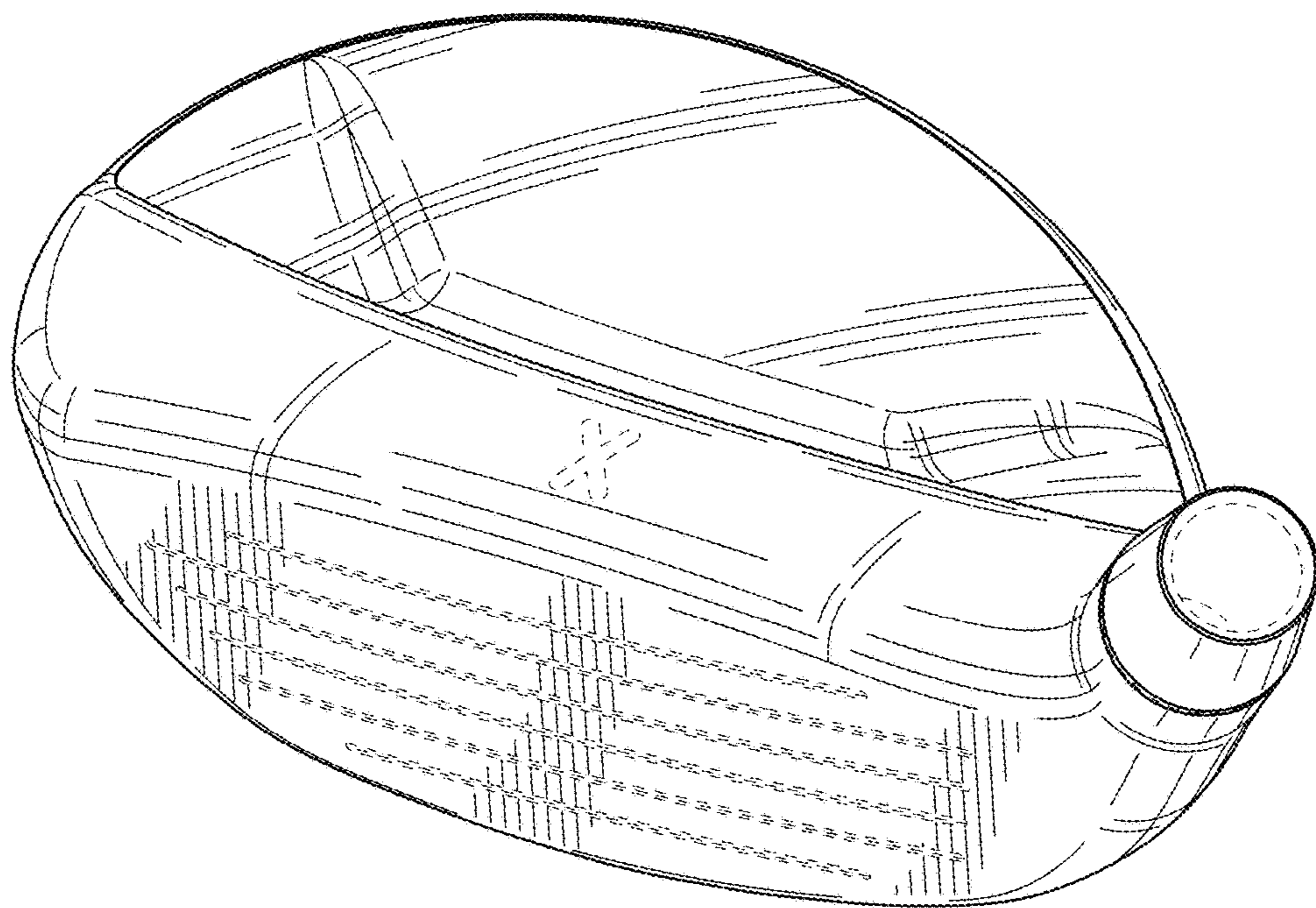

FIG. 9

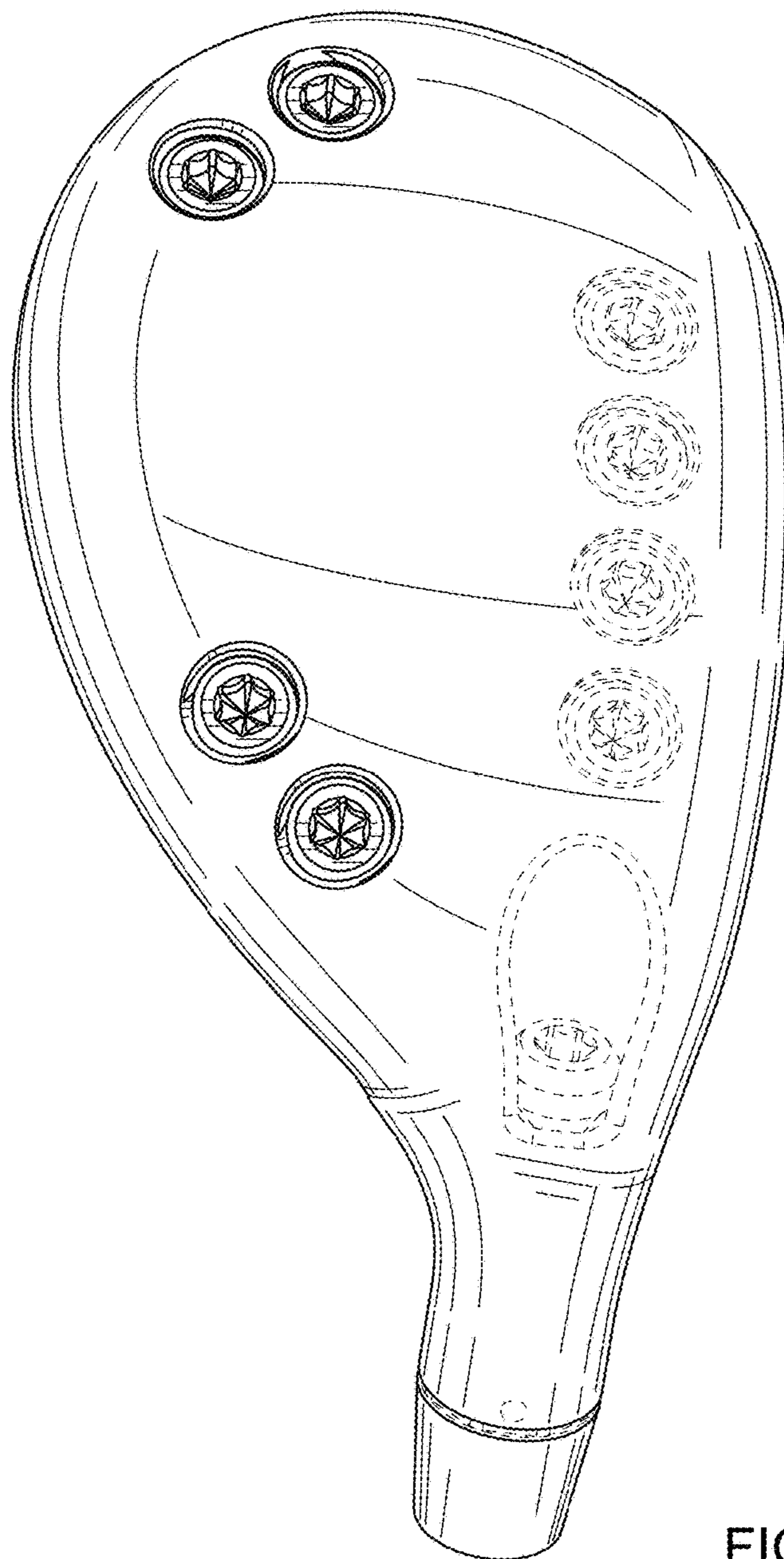

FIG. 10

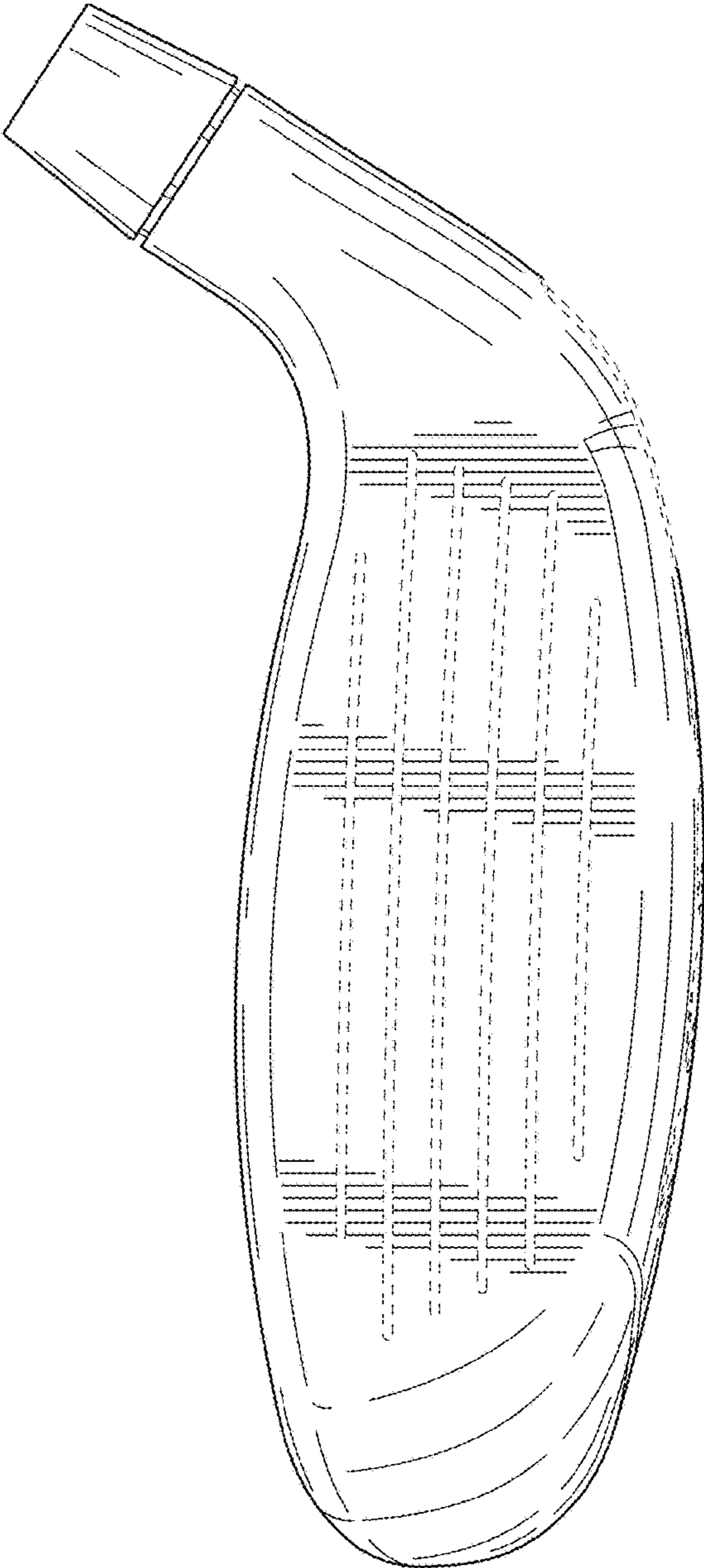

FIG. 11



FIG. 12

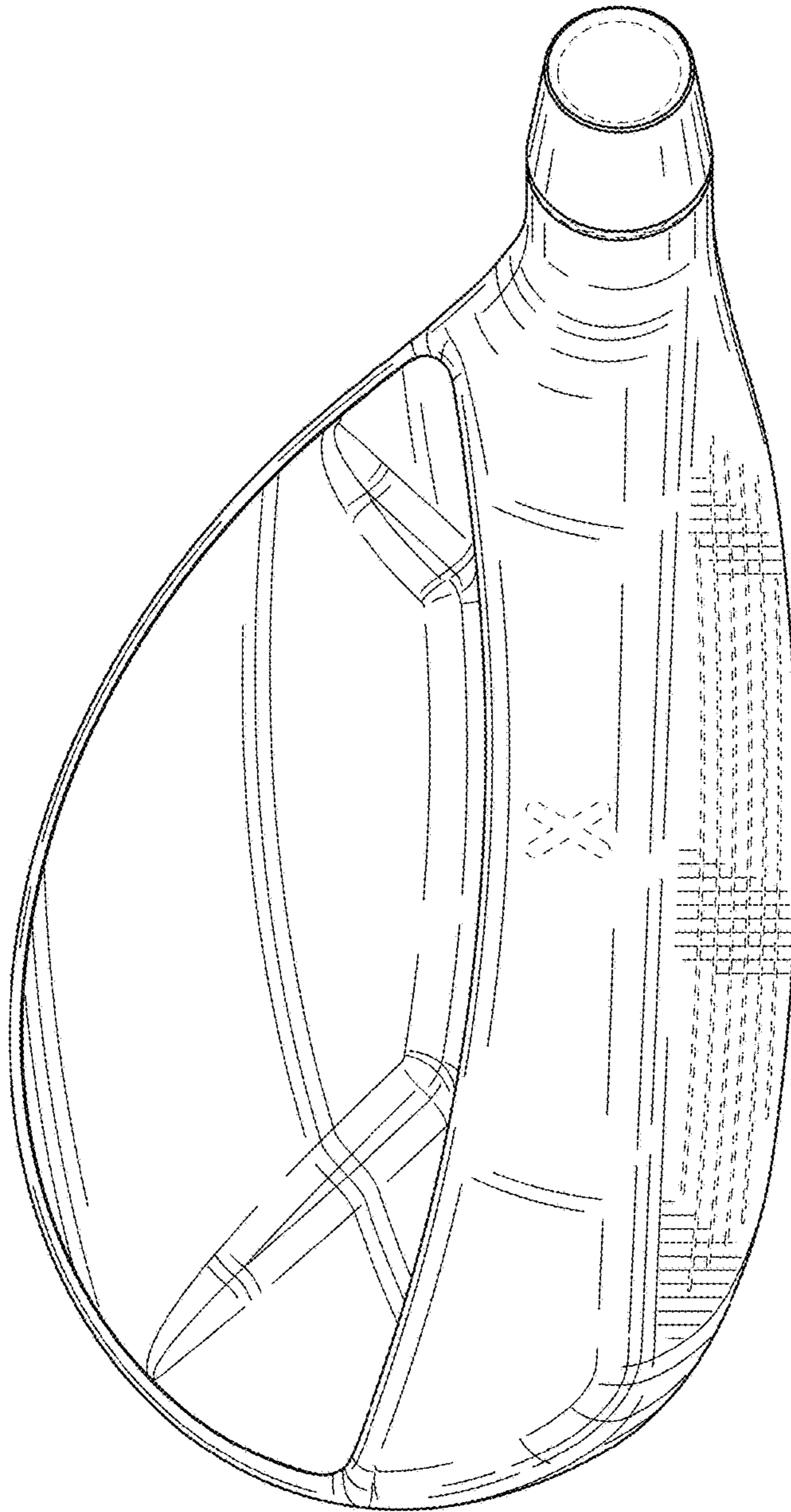

FIG. 13

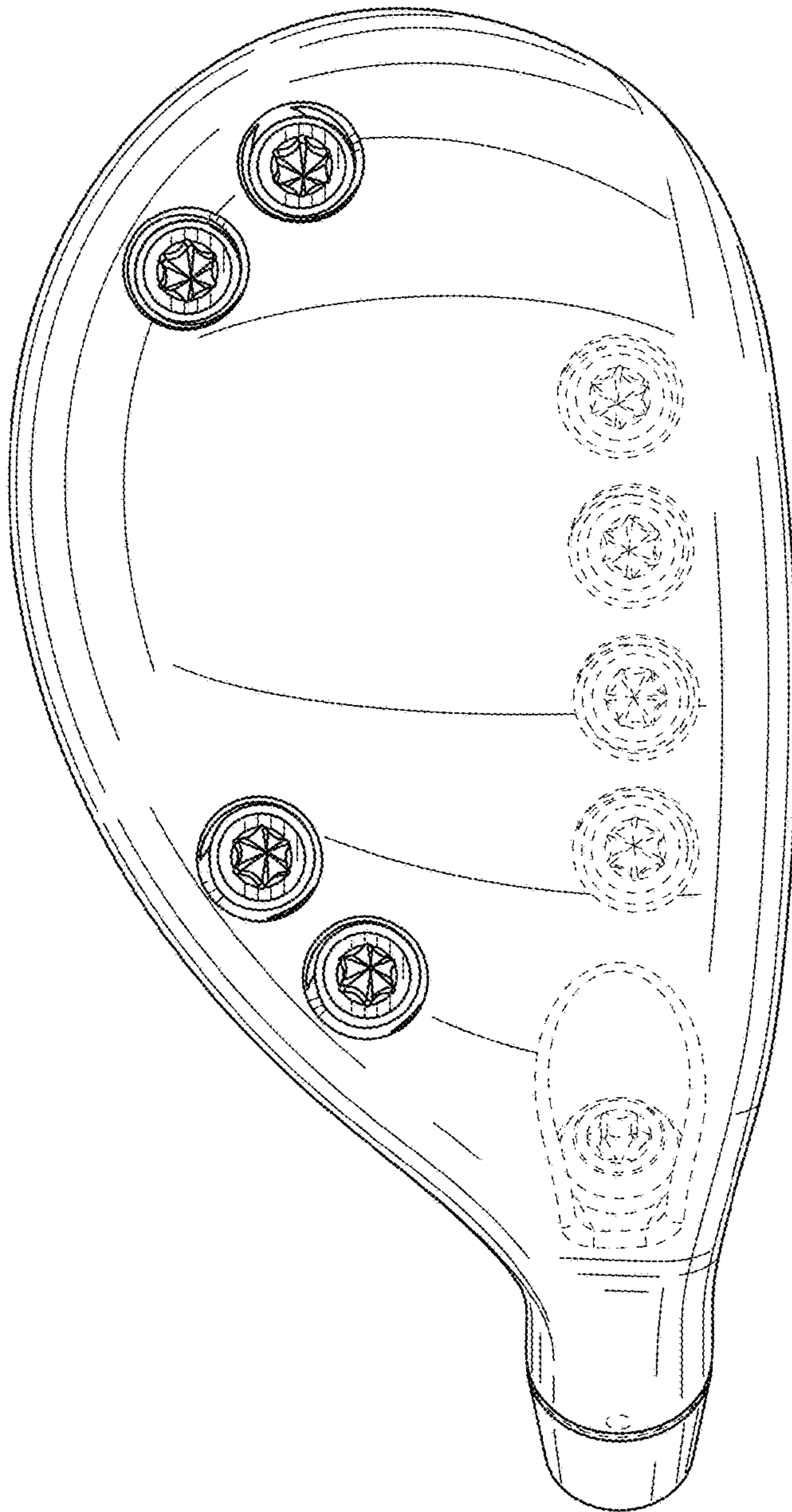

FIG. 14

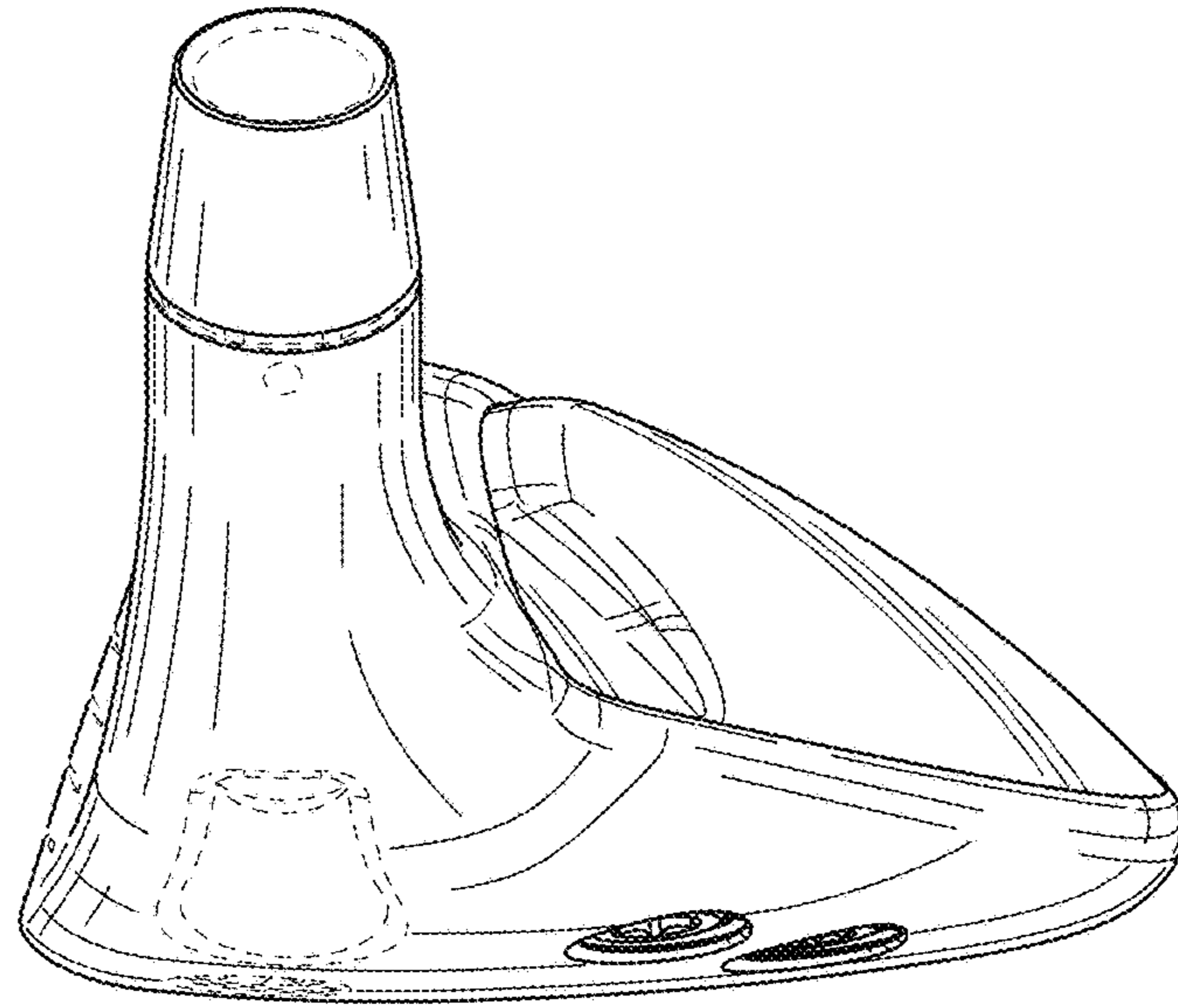

FIG. 15

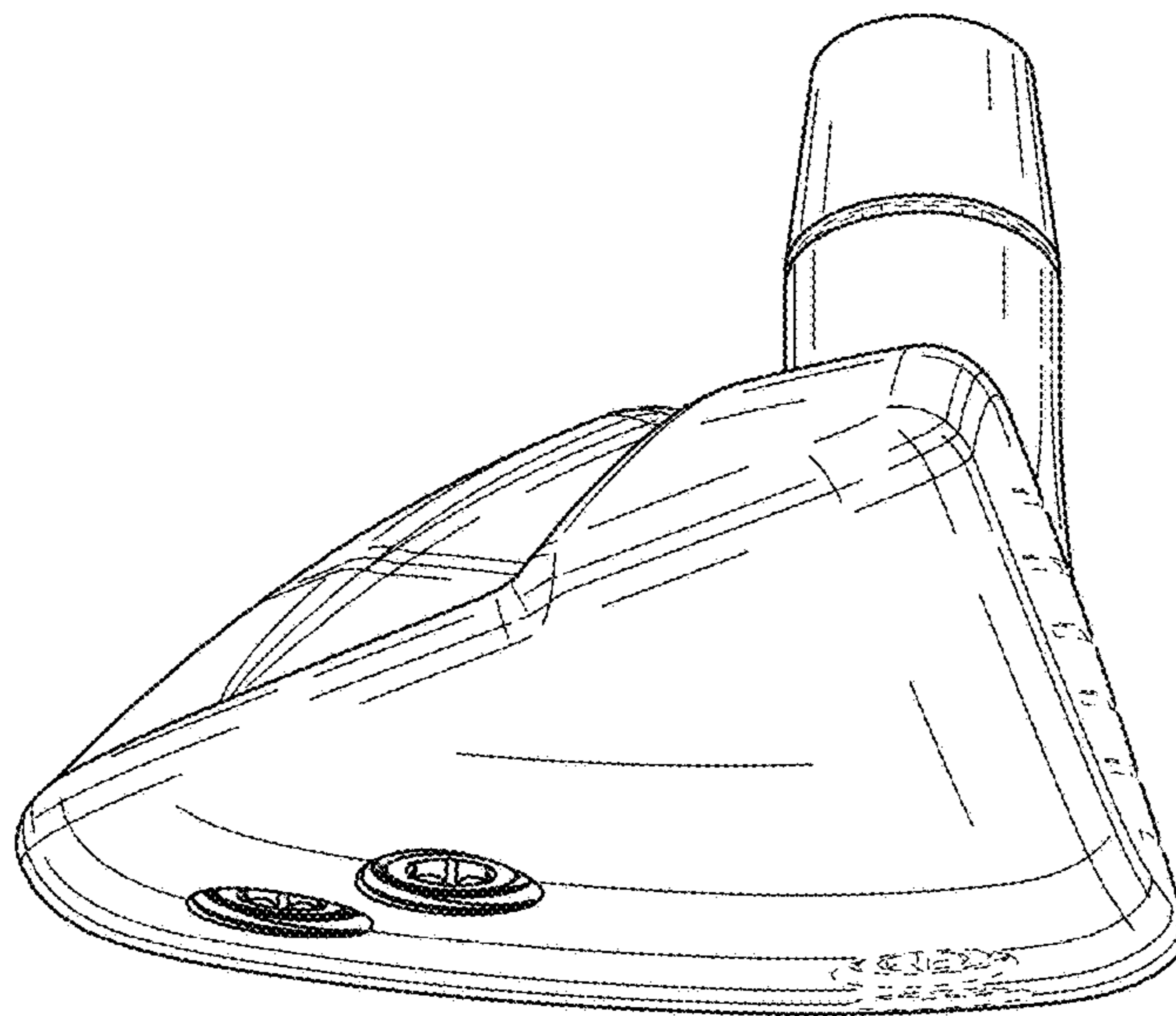

FIG. 16

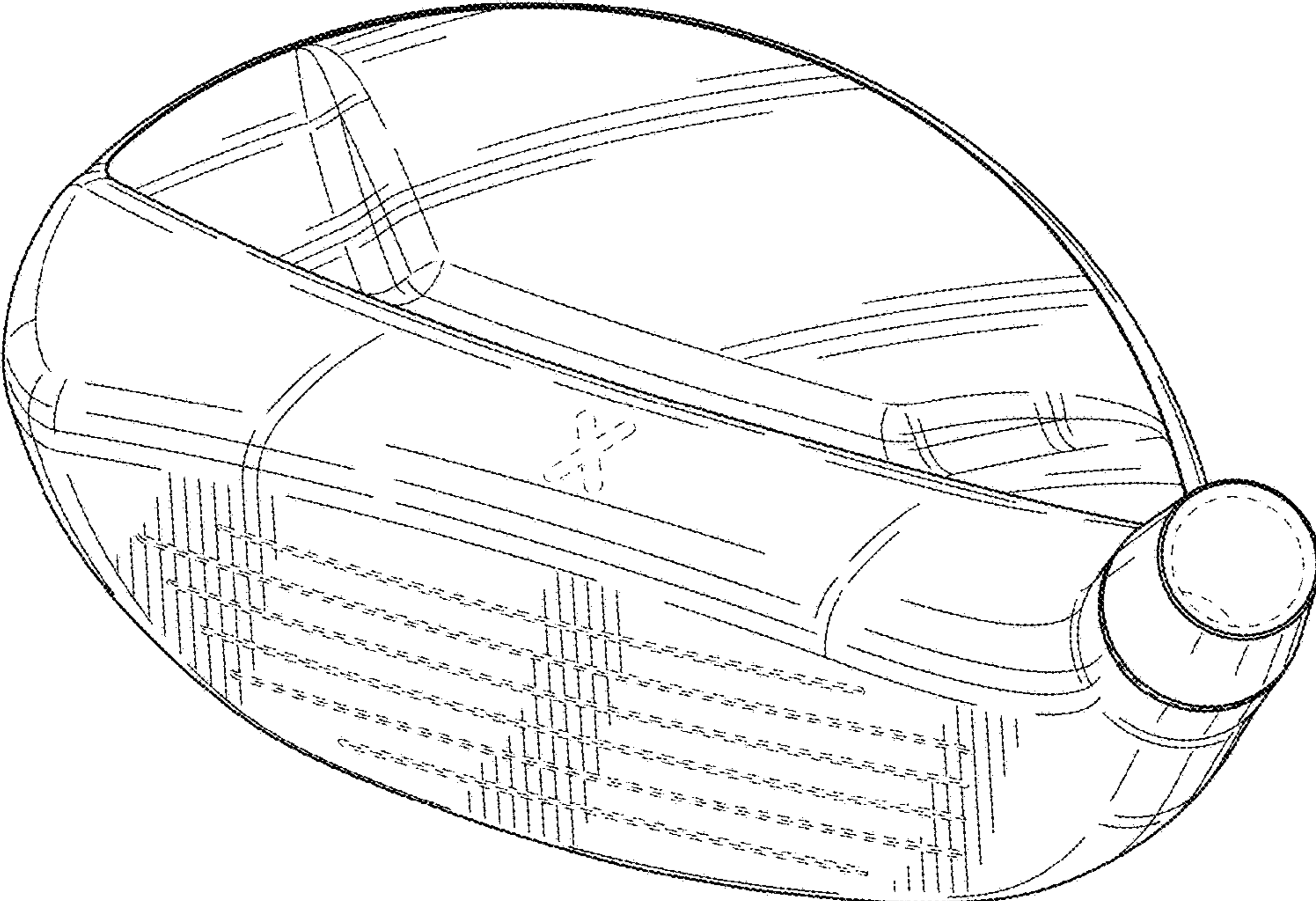

FIG. 17

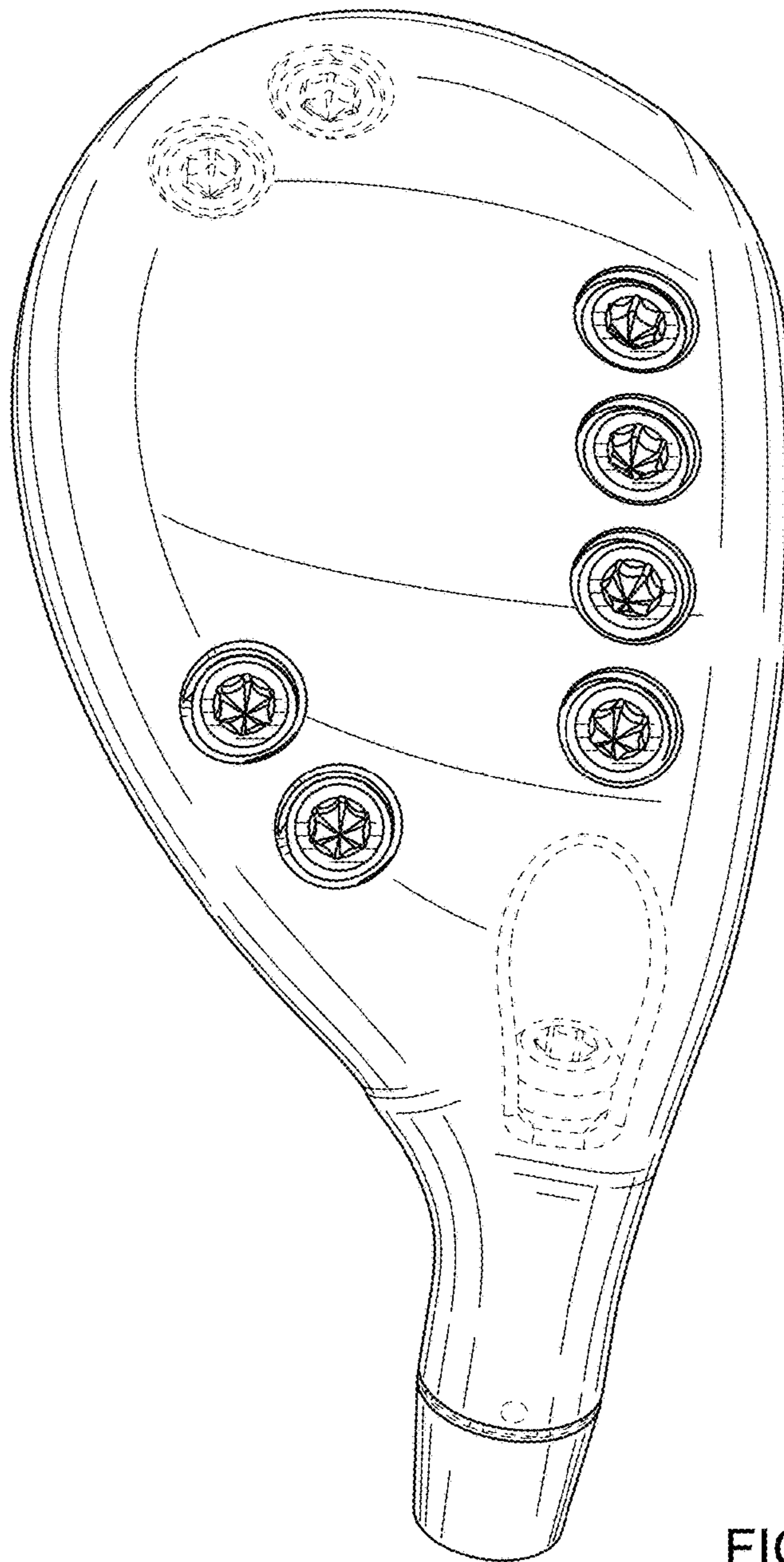

FIG. 18

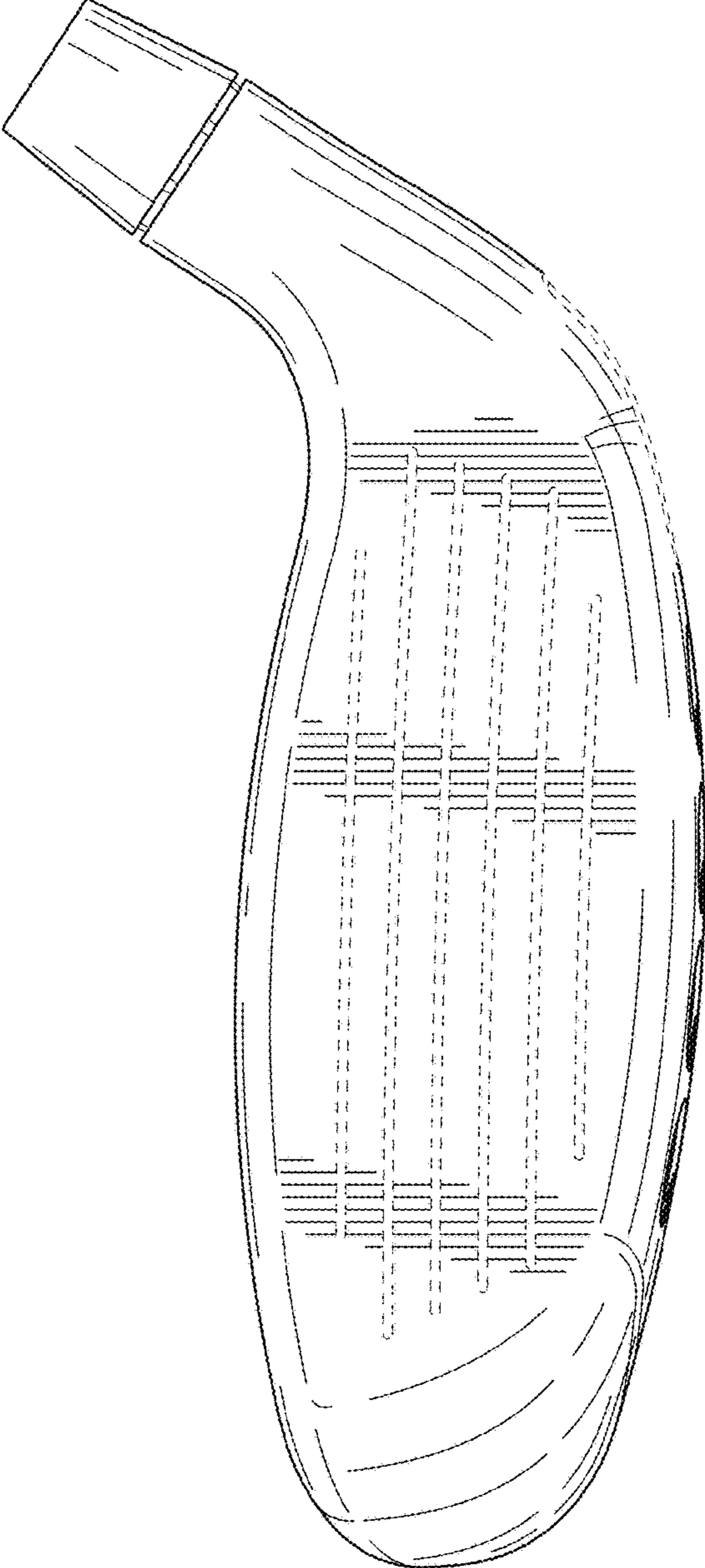

FIG. 19



FIG. 20

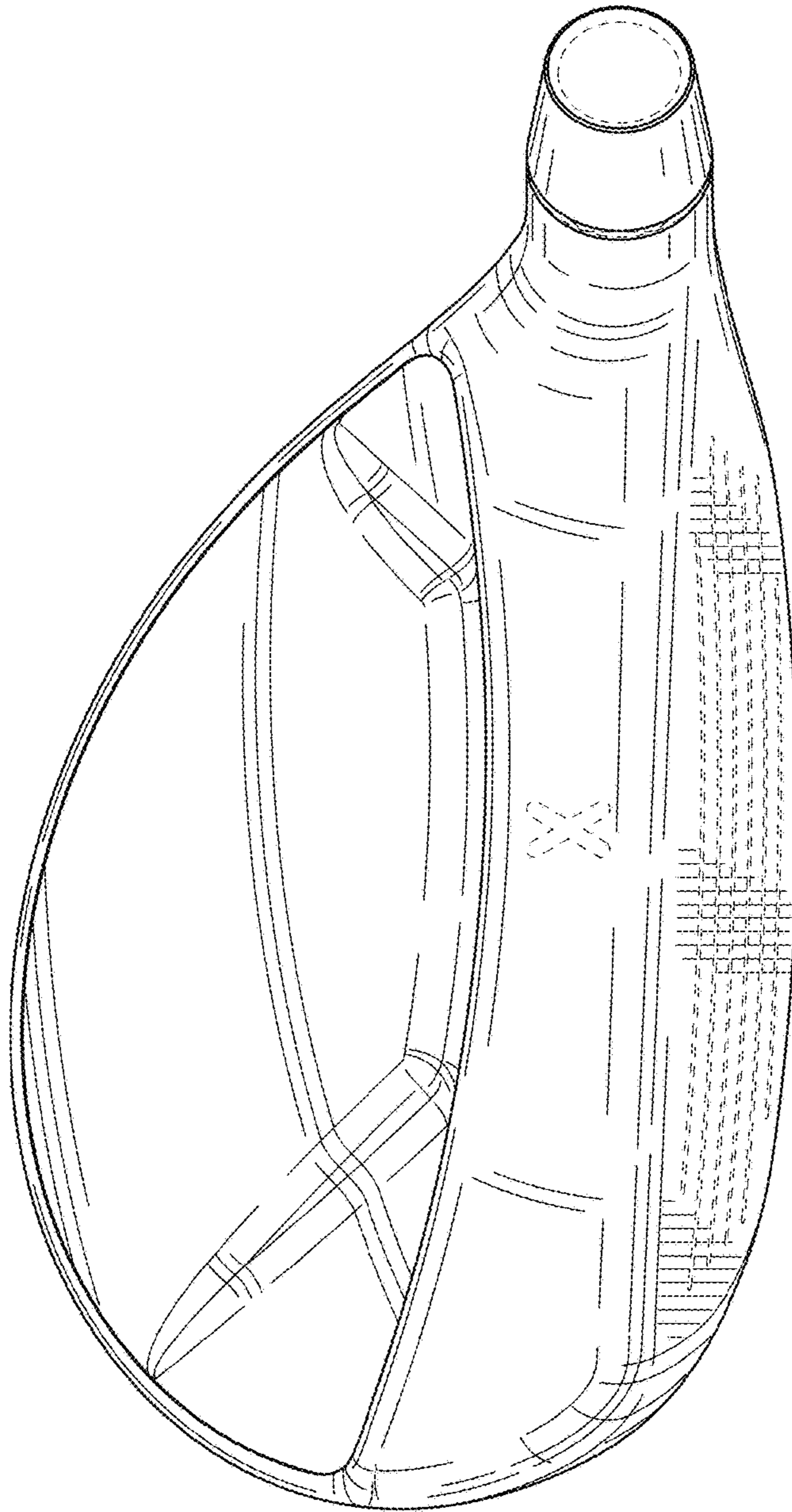

FIG. 21

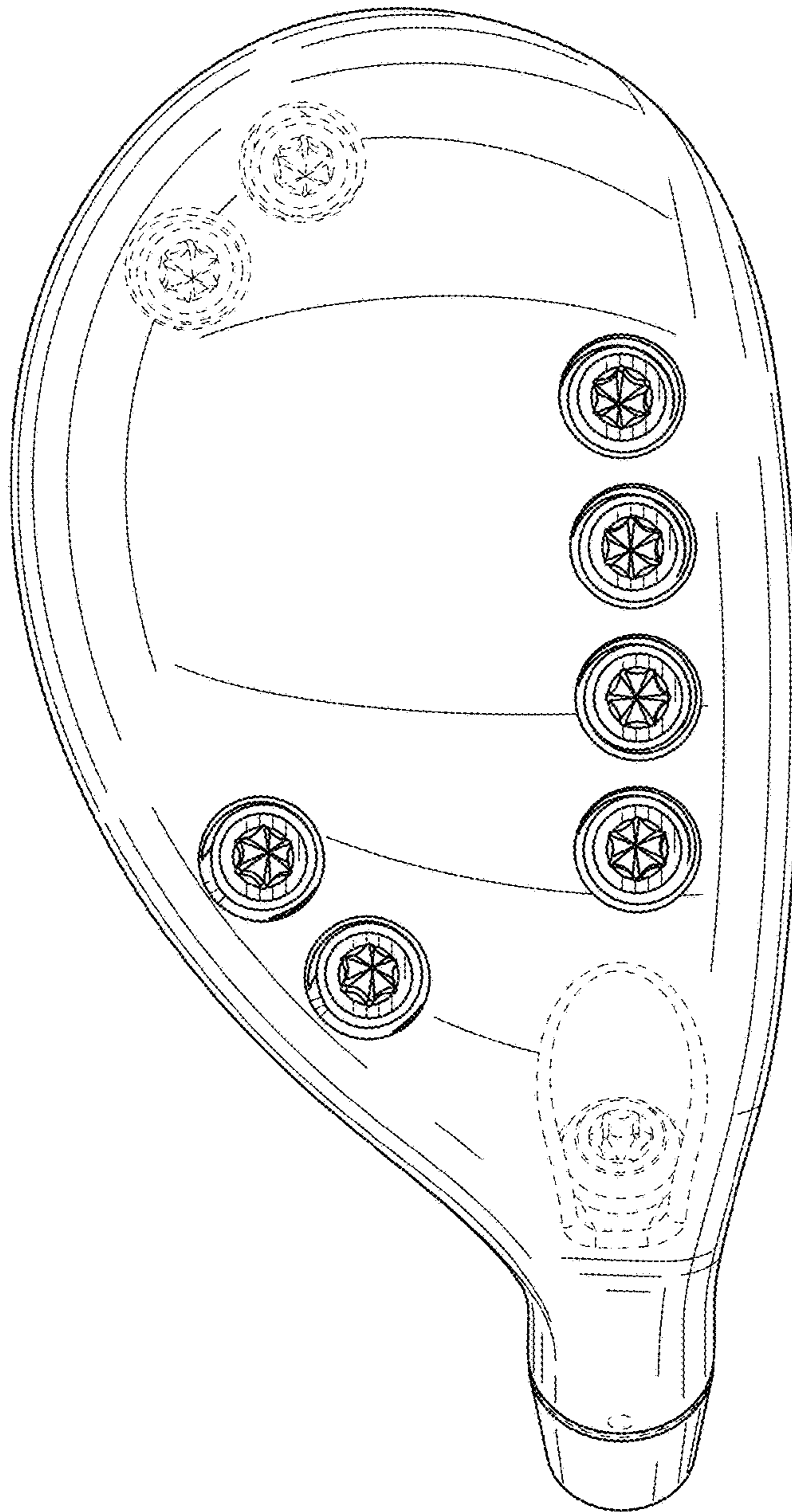

FIG. 22

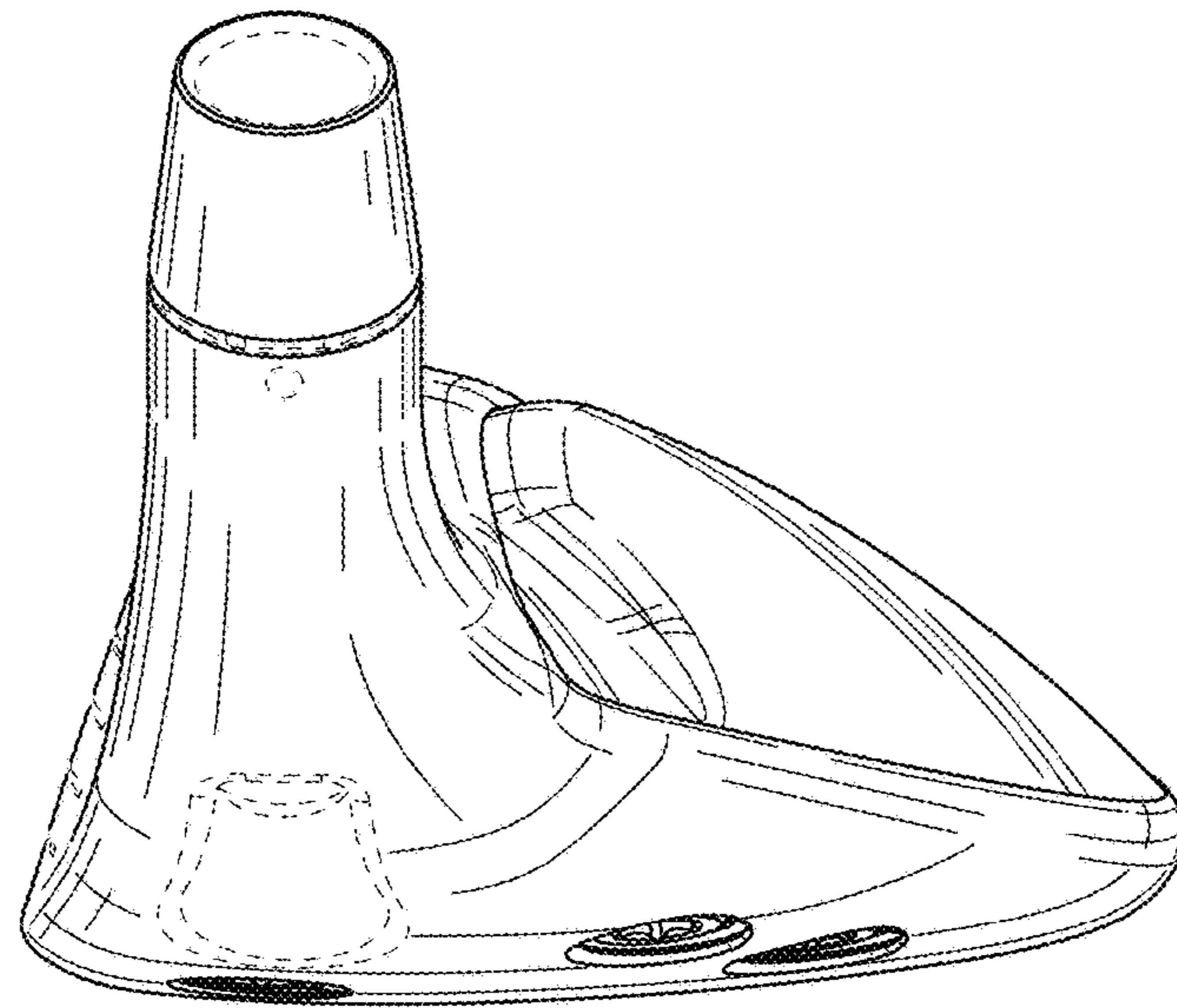

FIG. 23

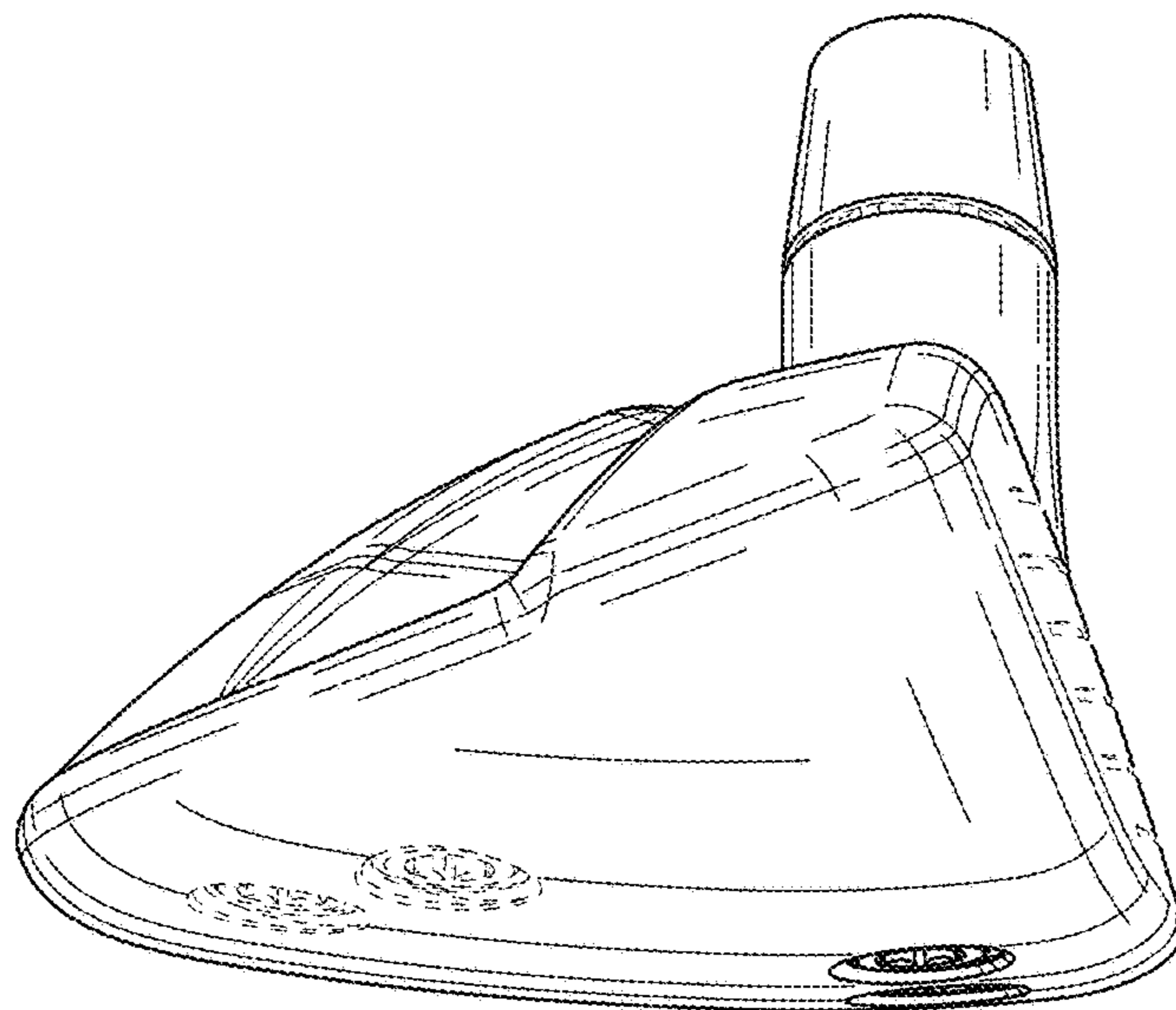

FIG. 24

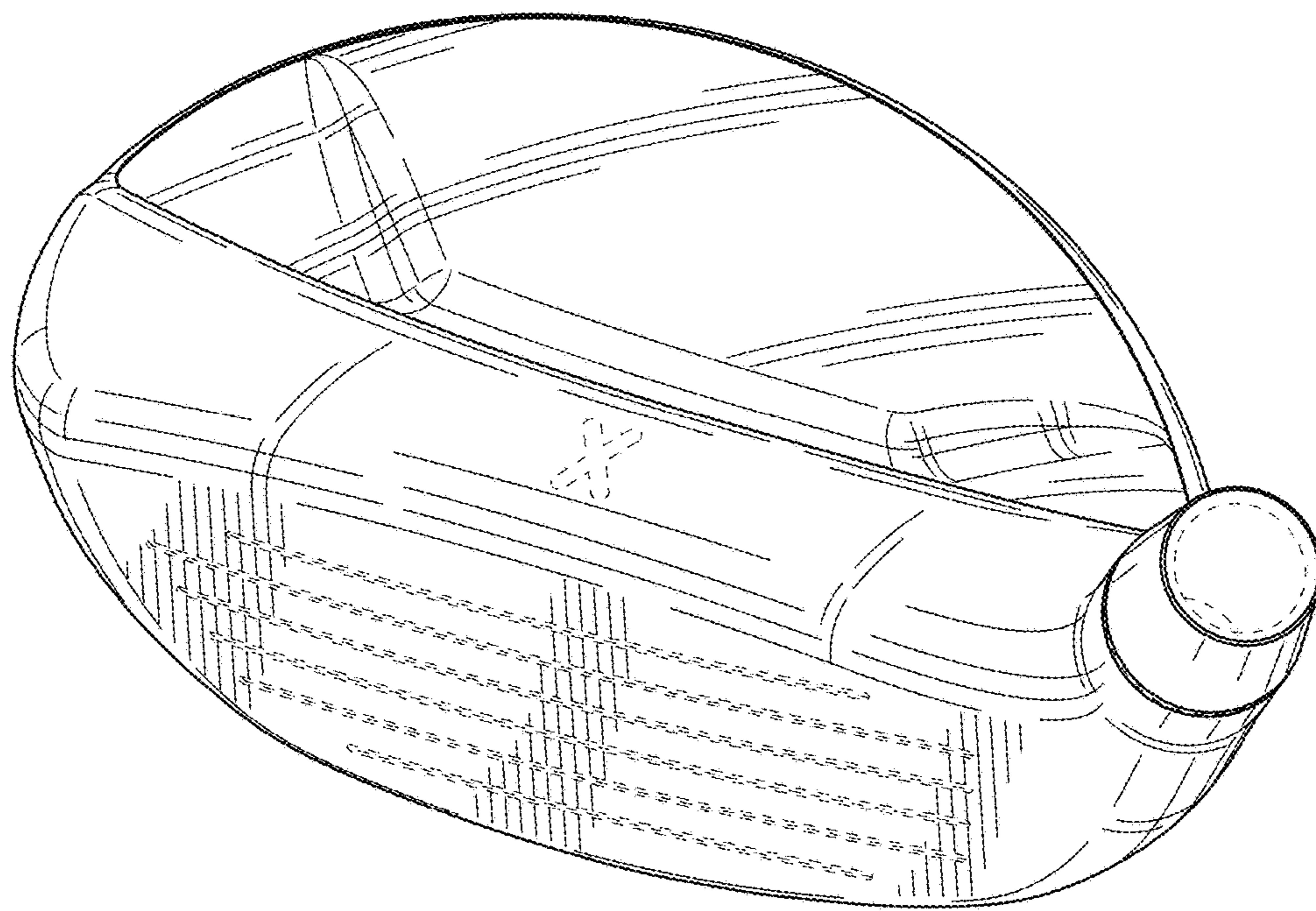

FIG. 25

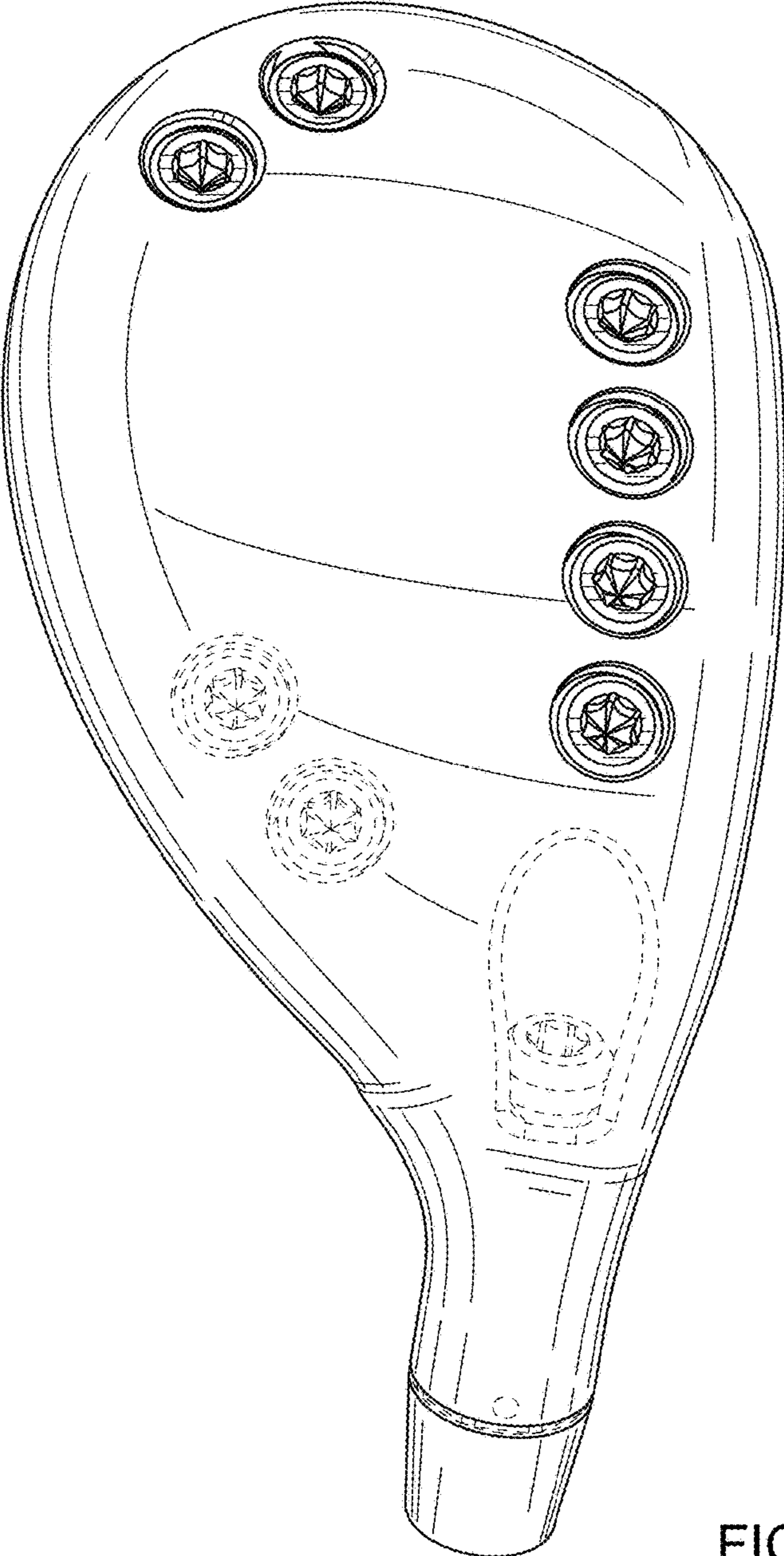

FIG. 26

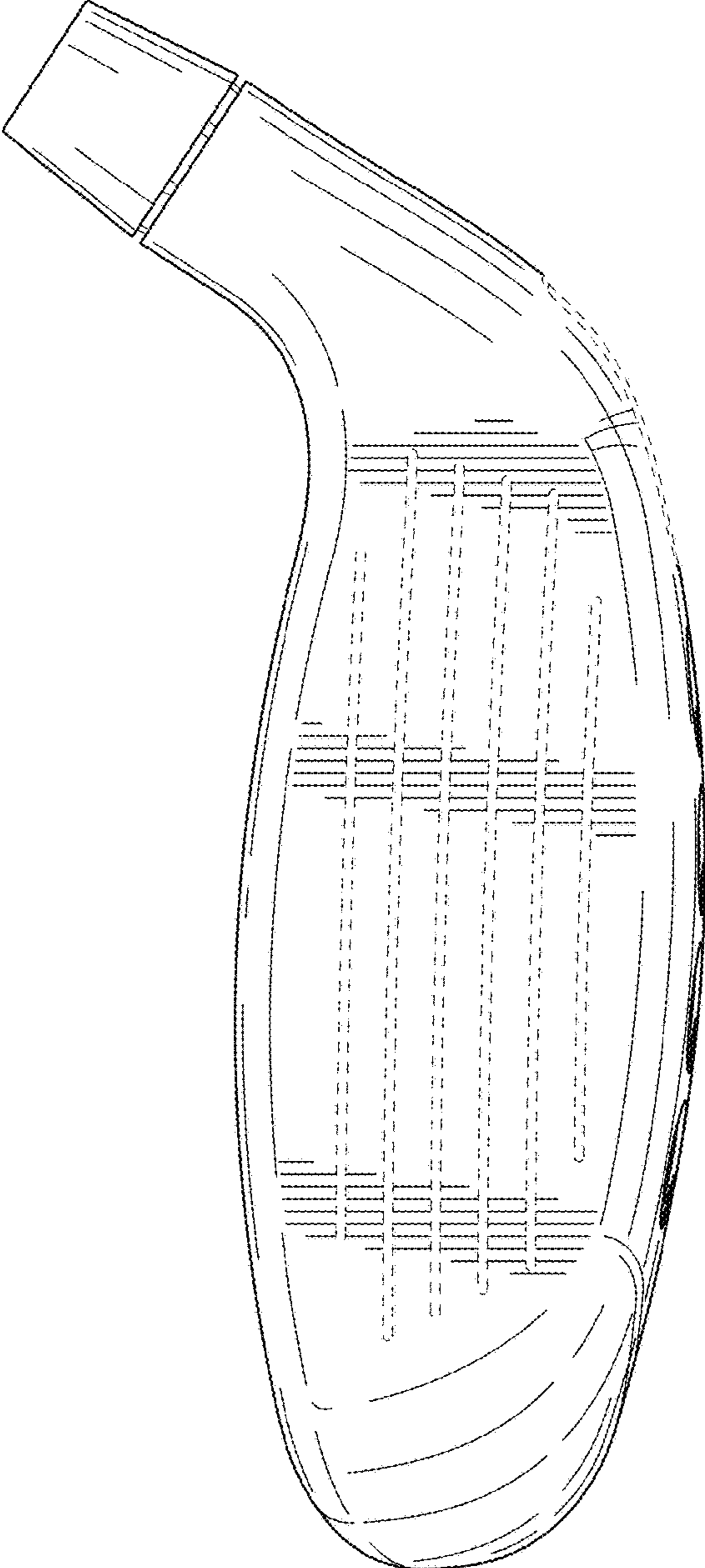

FIG. 27

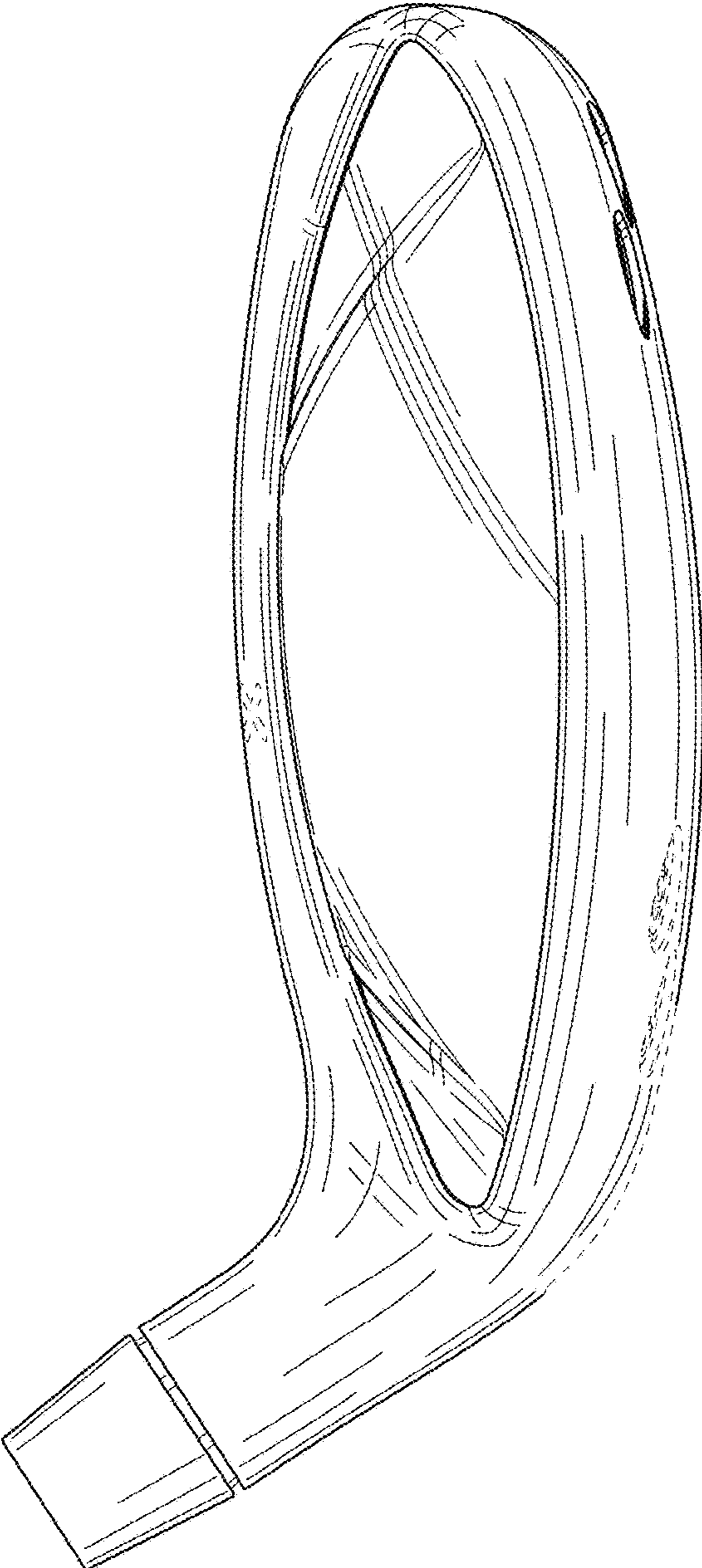

FIG. 28

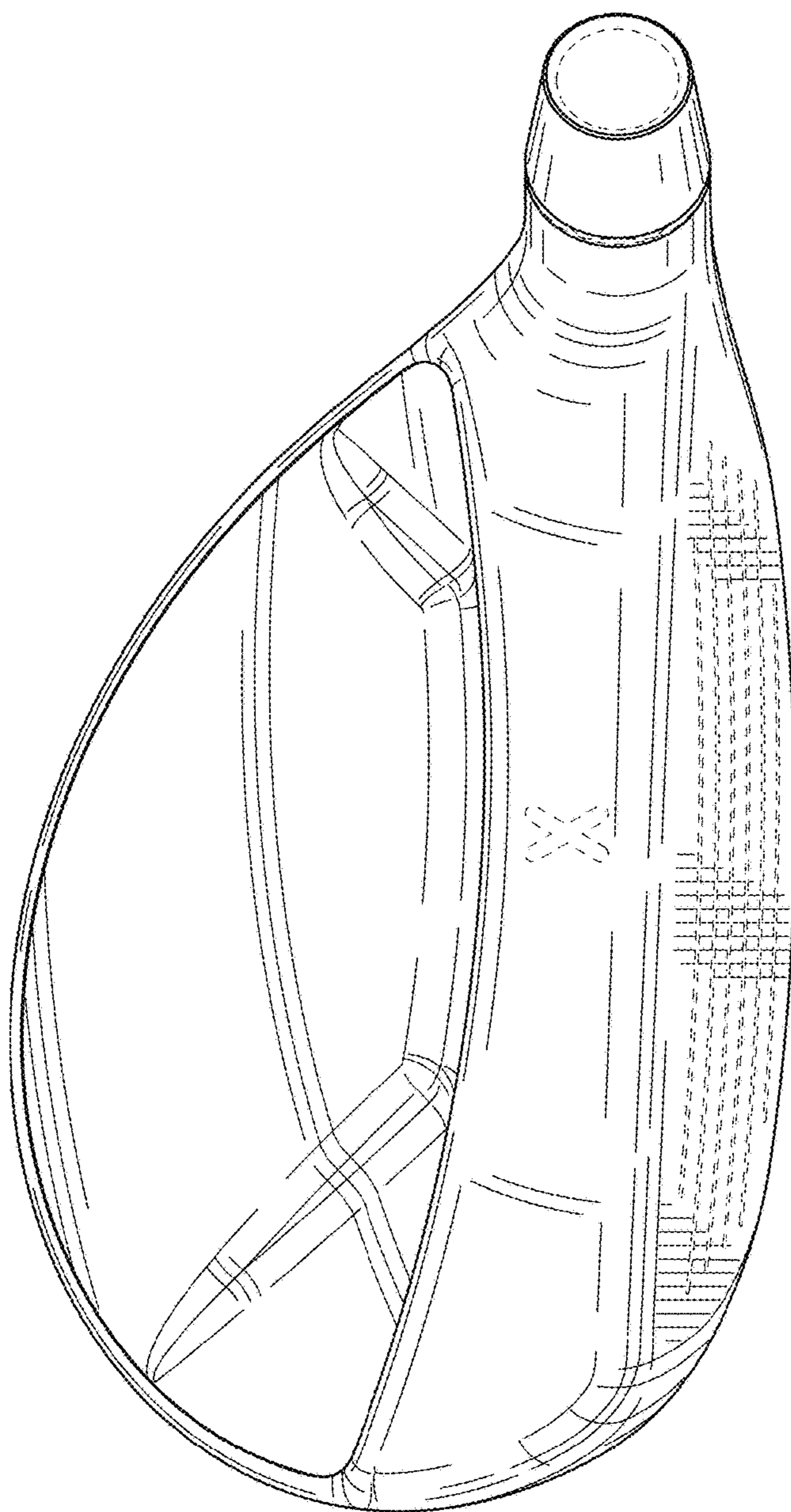

FIG. 29

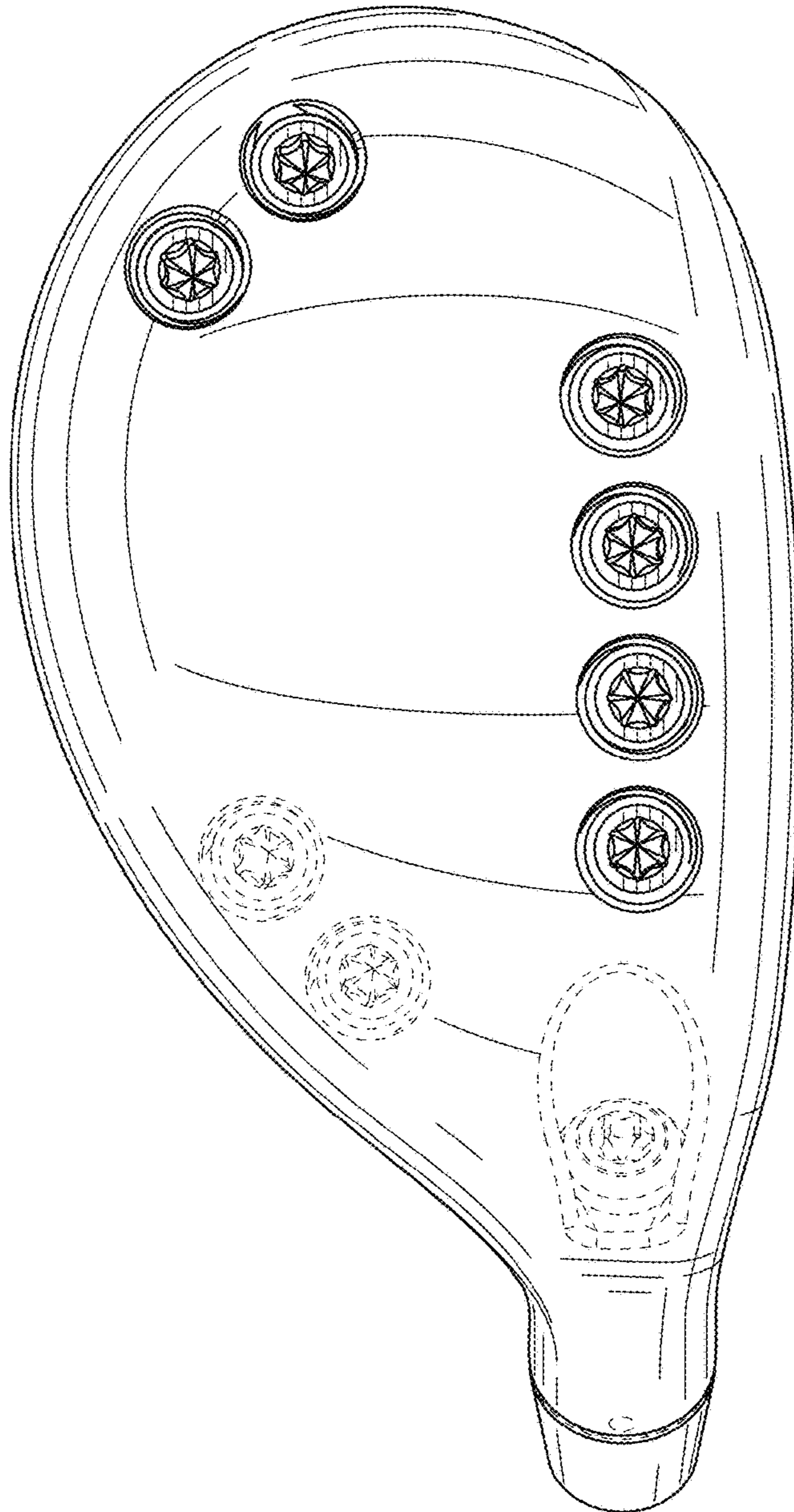

FIG. 30

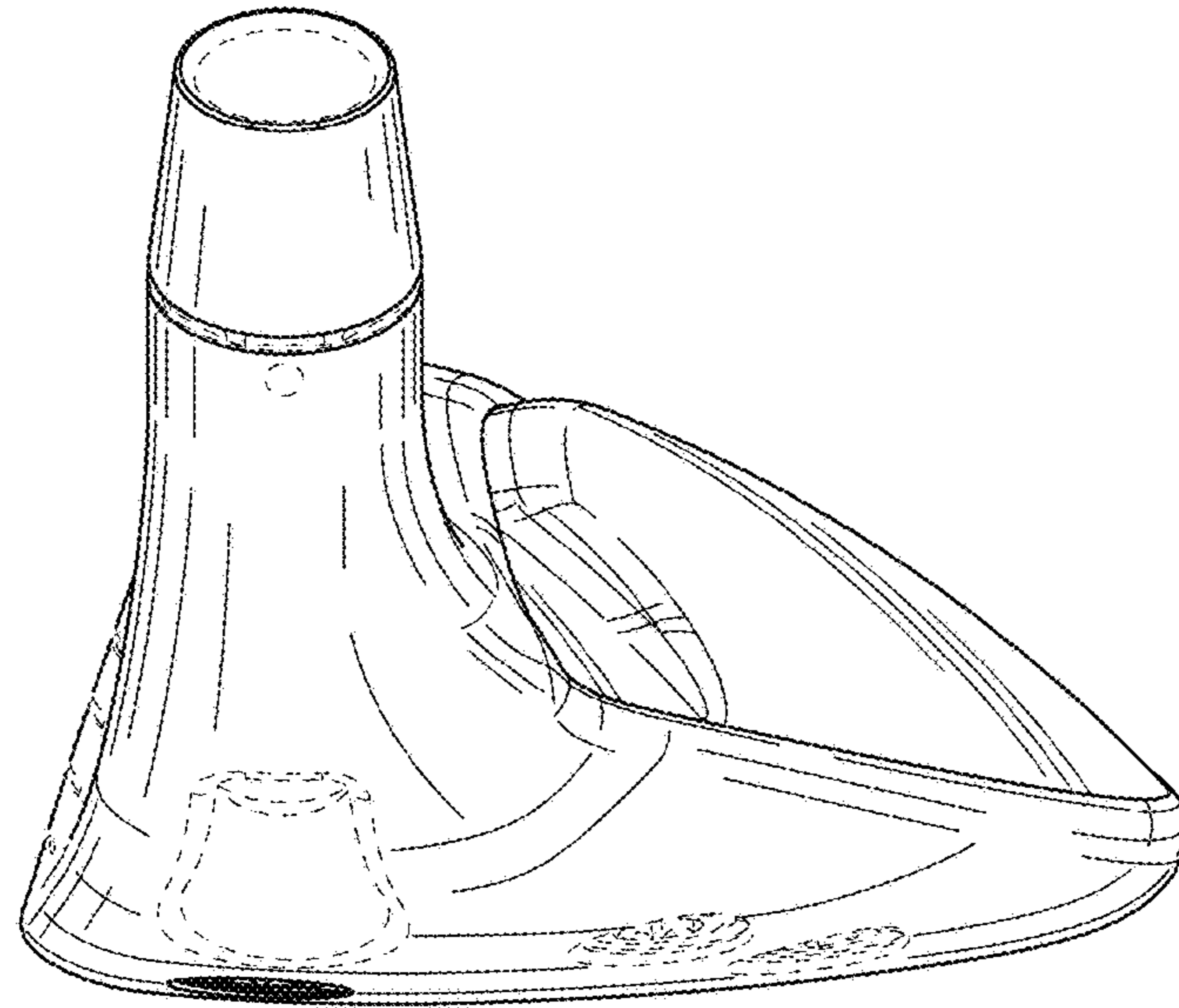

FIG. 31

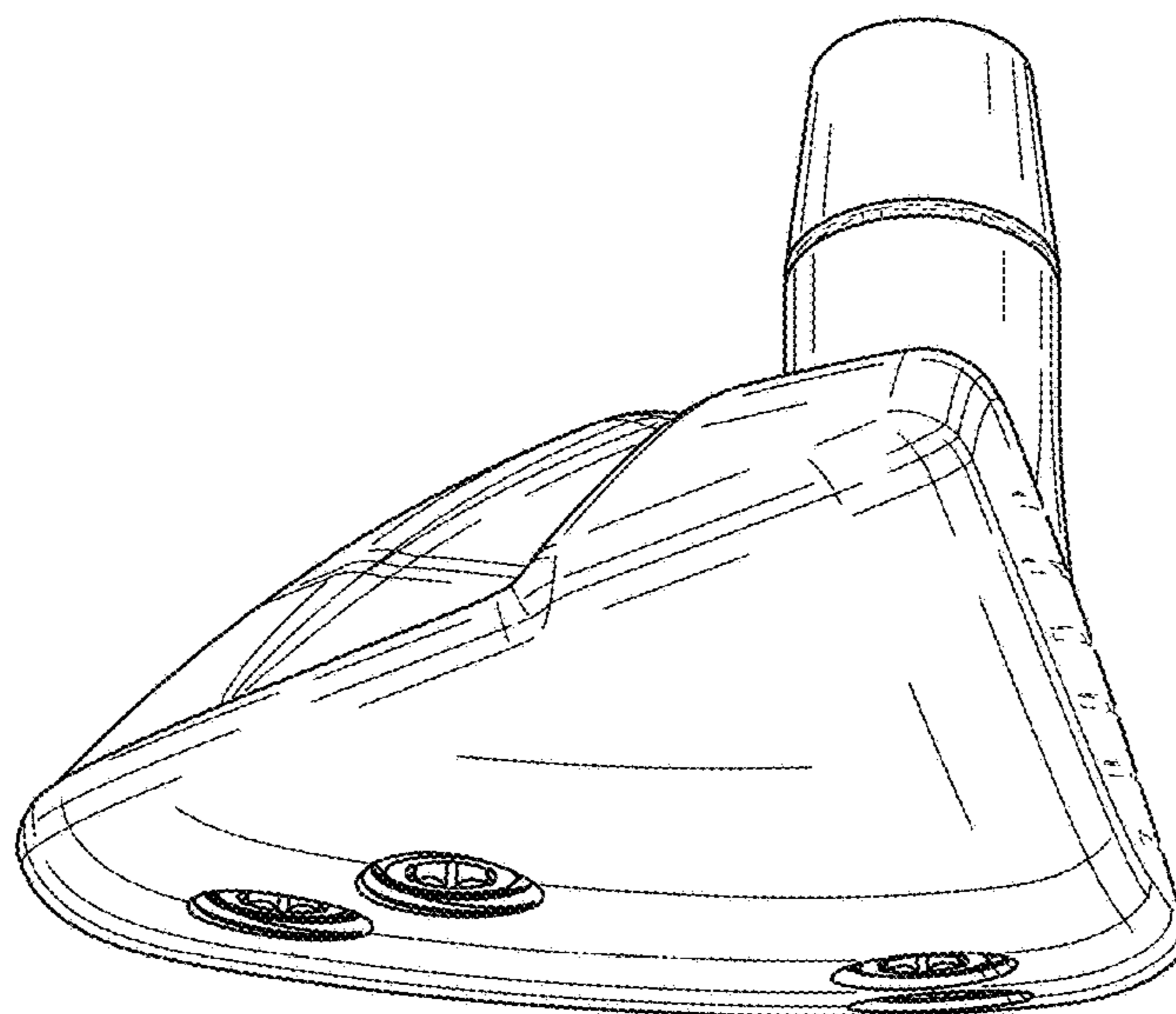

FIG. 32

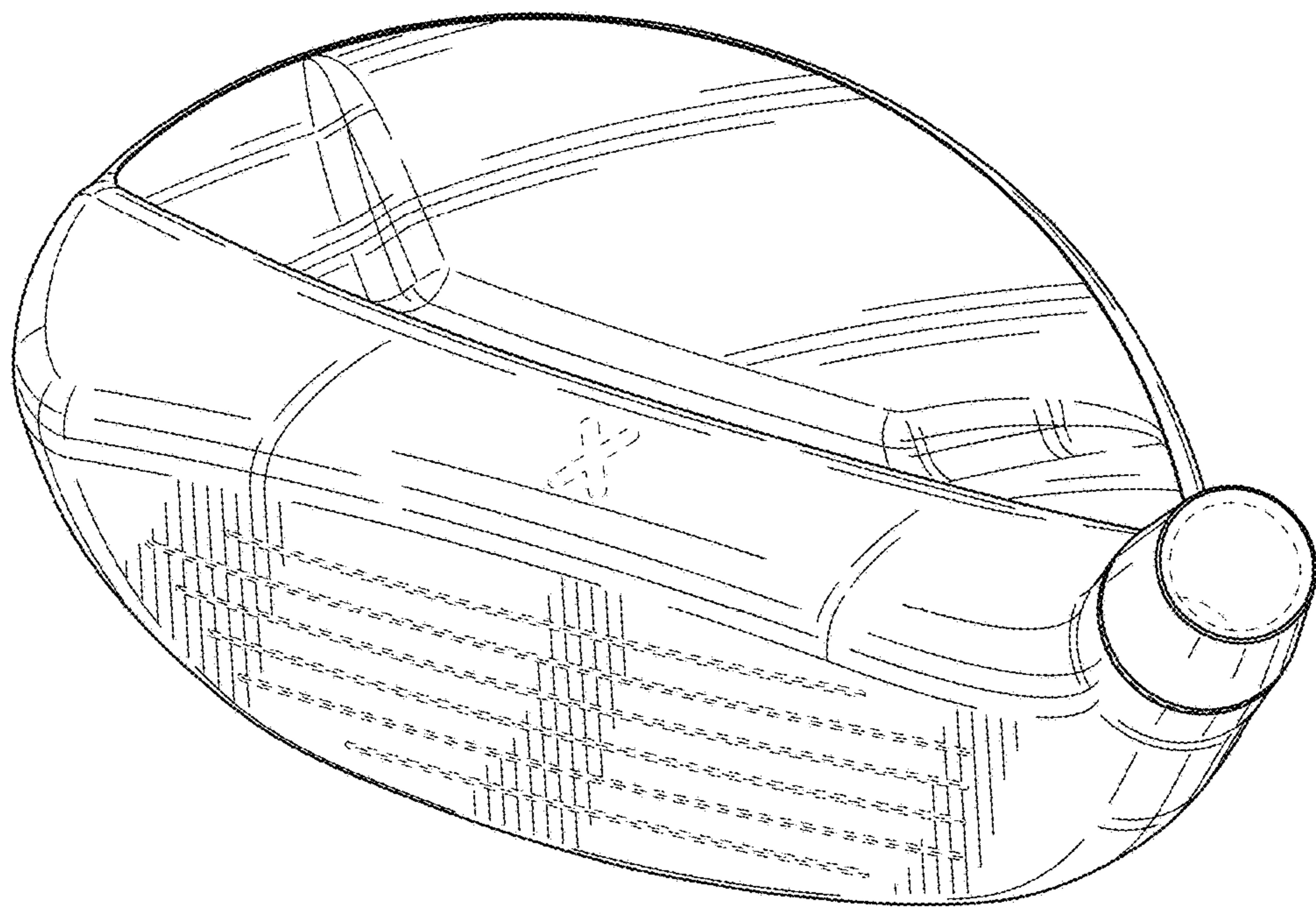

FIG. 33

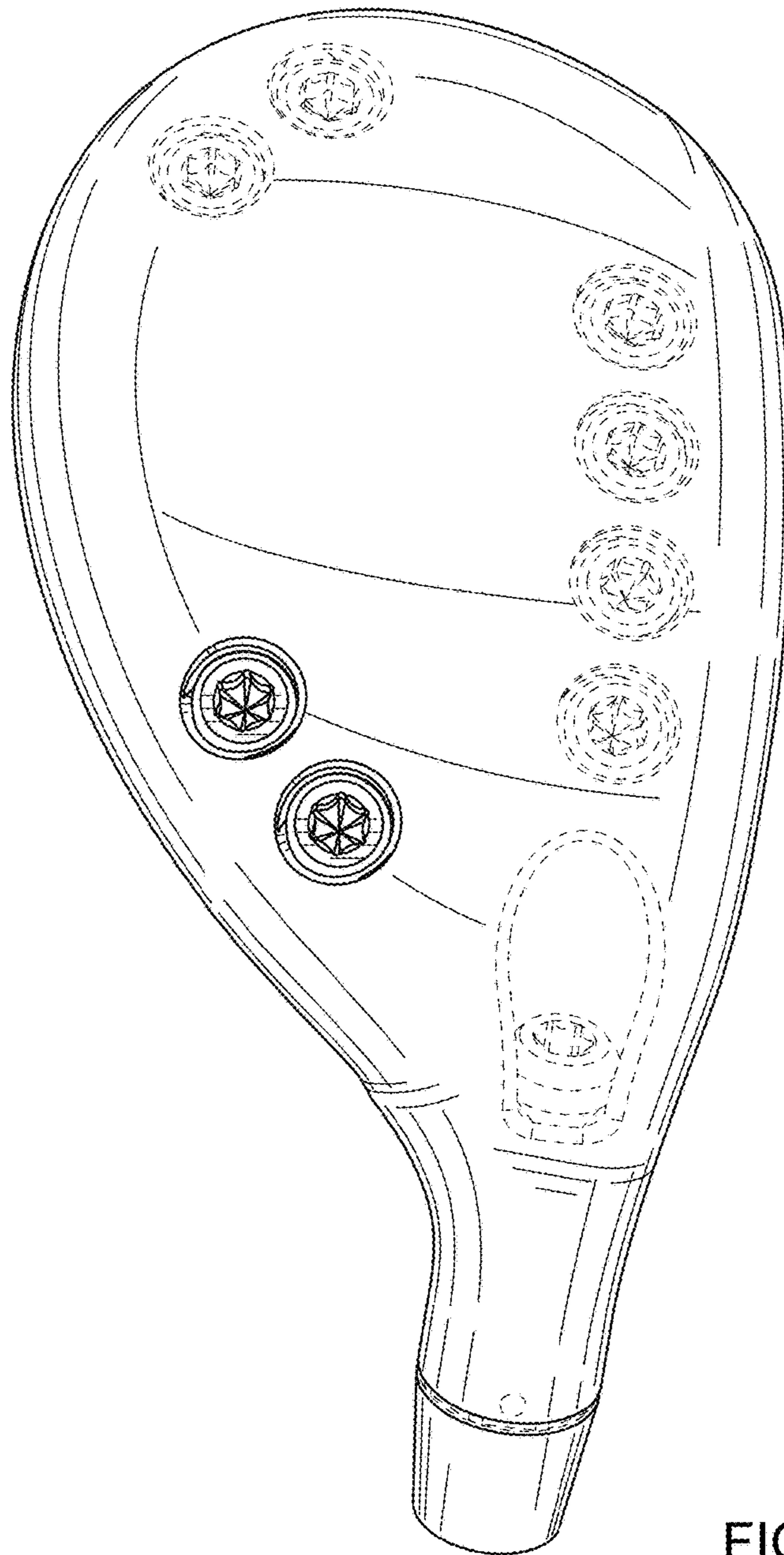

FIG. 34

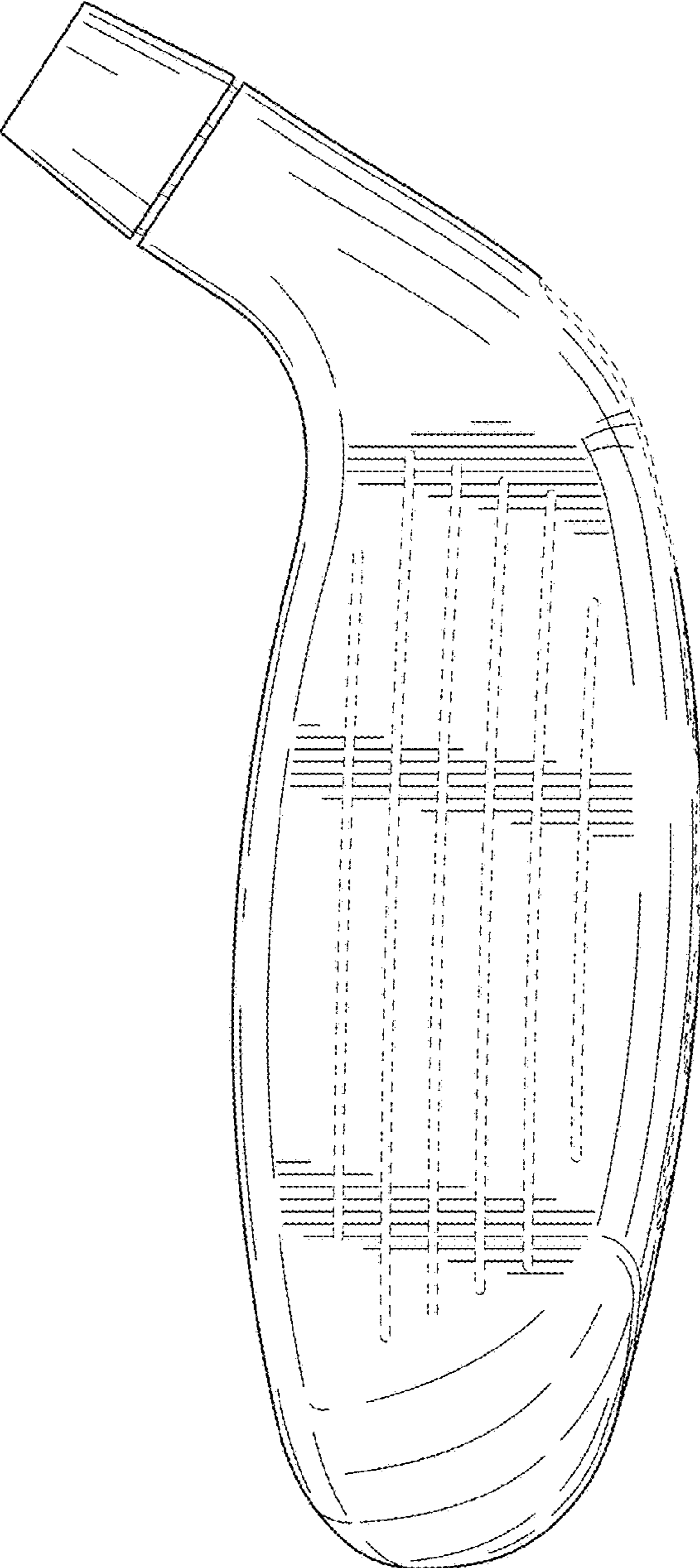

FIG. 35



FIG. 36

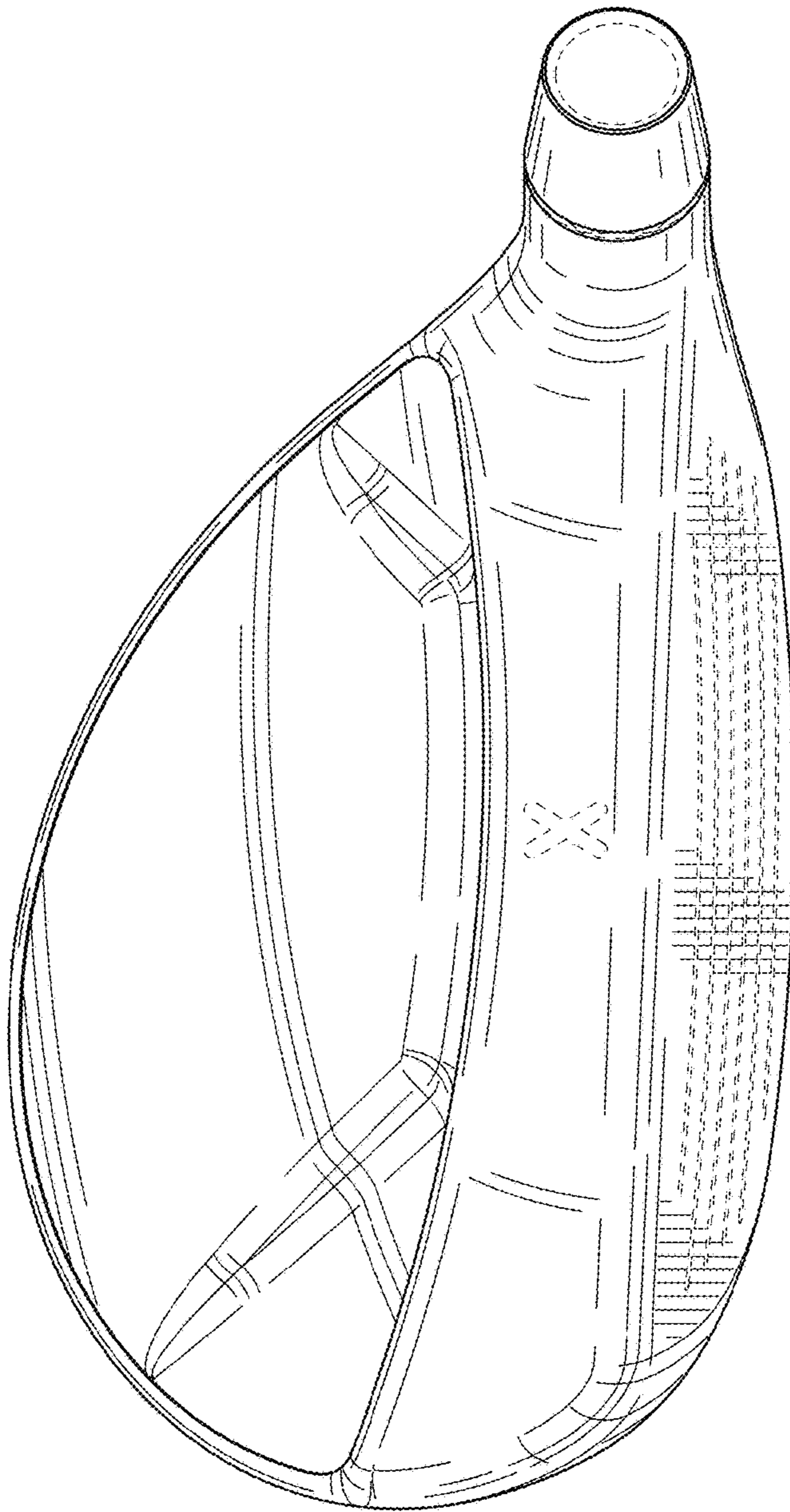

FIG. 37

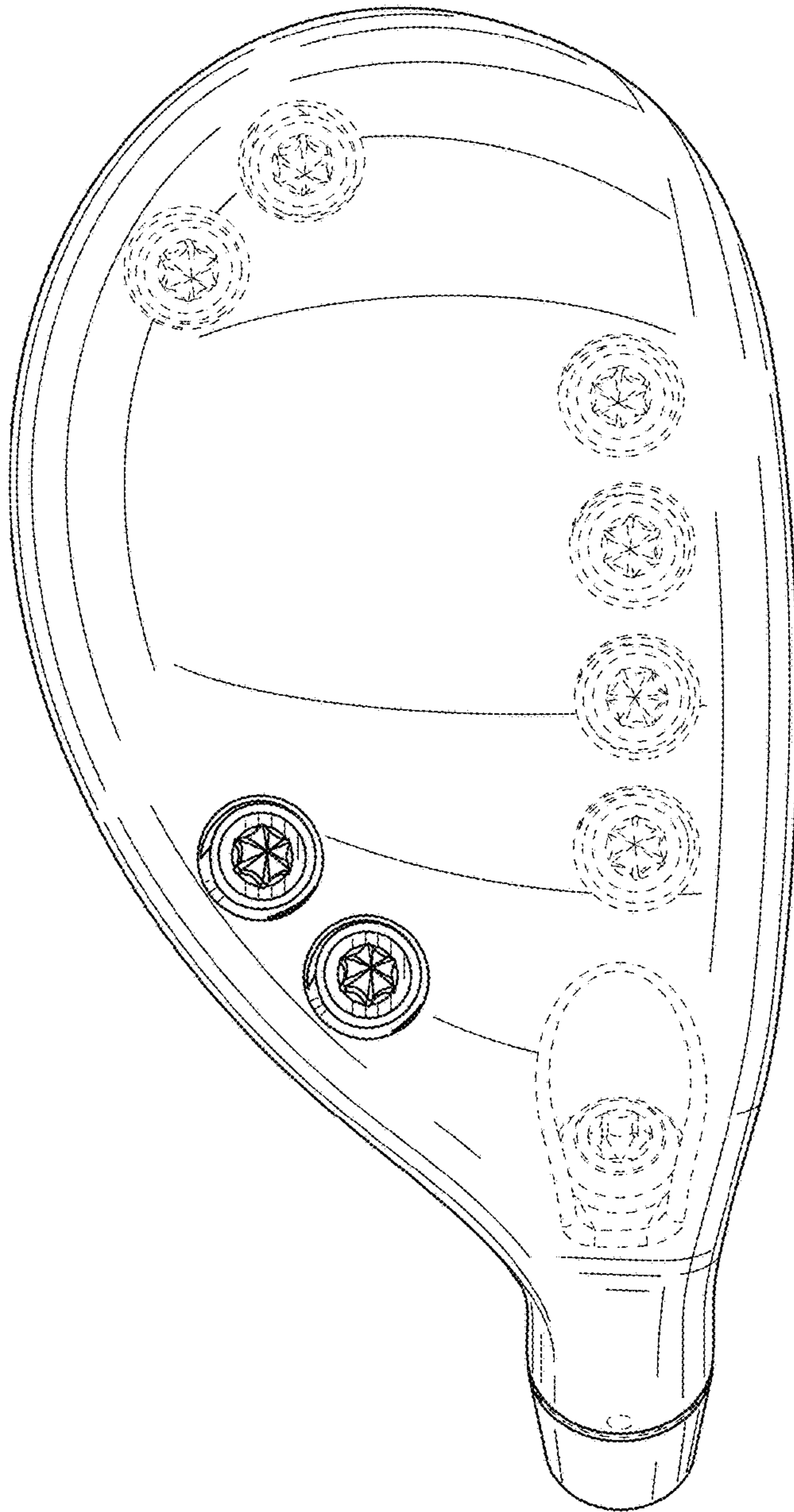

FIG. 38

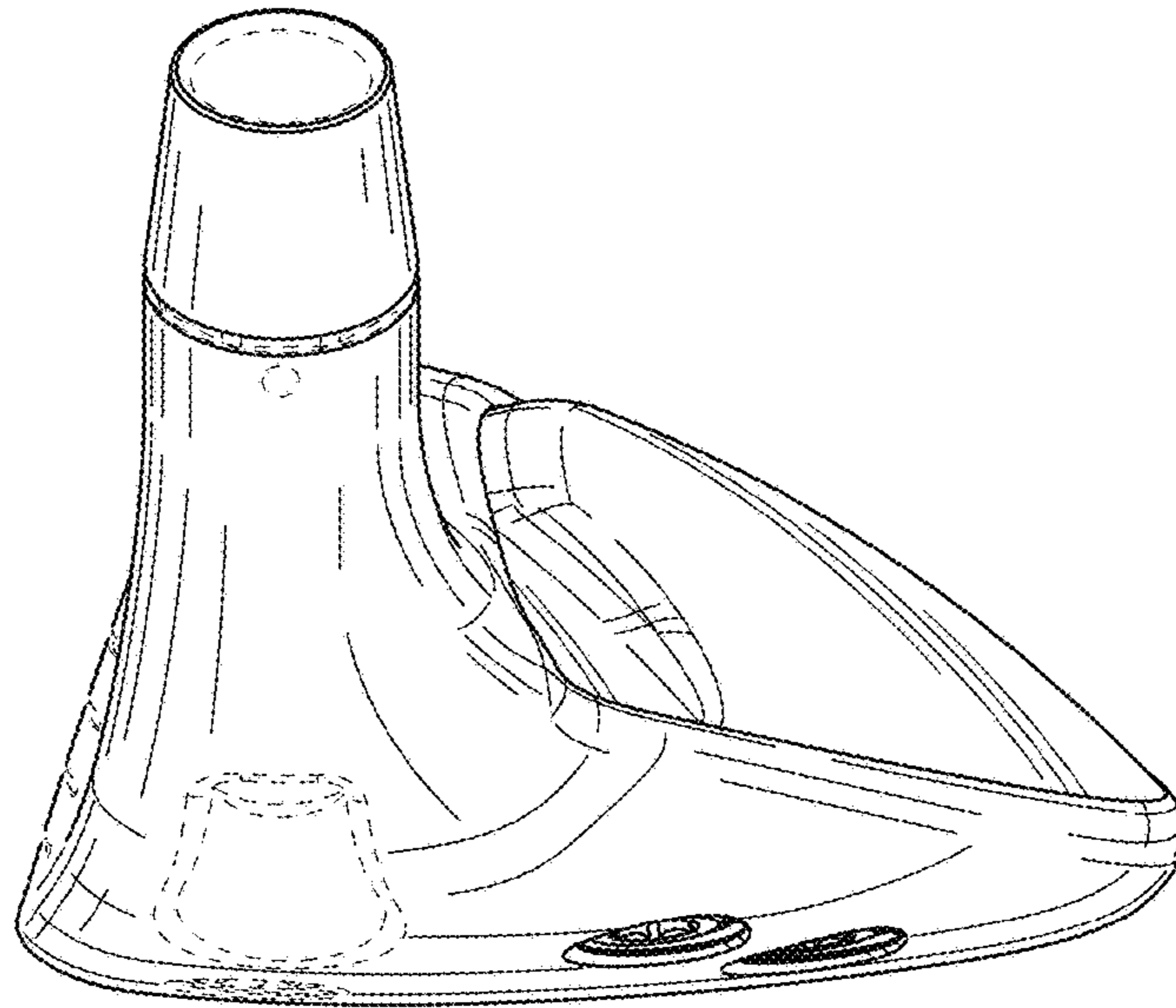

FIG. 39

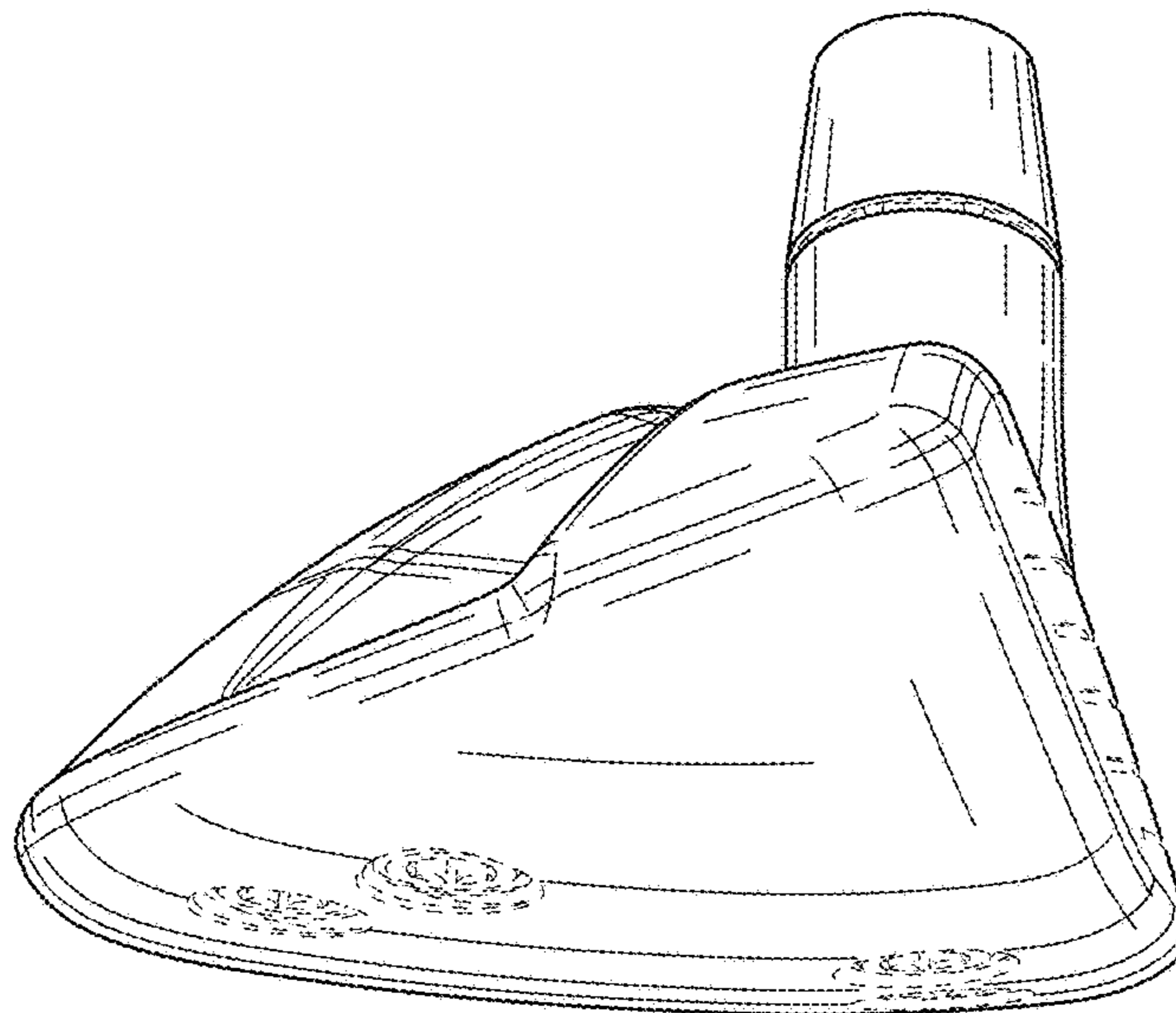

FIG. 40

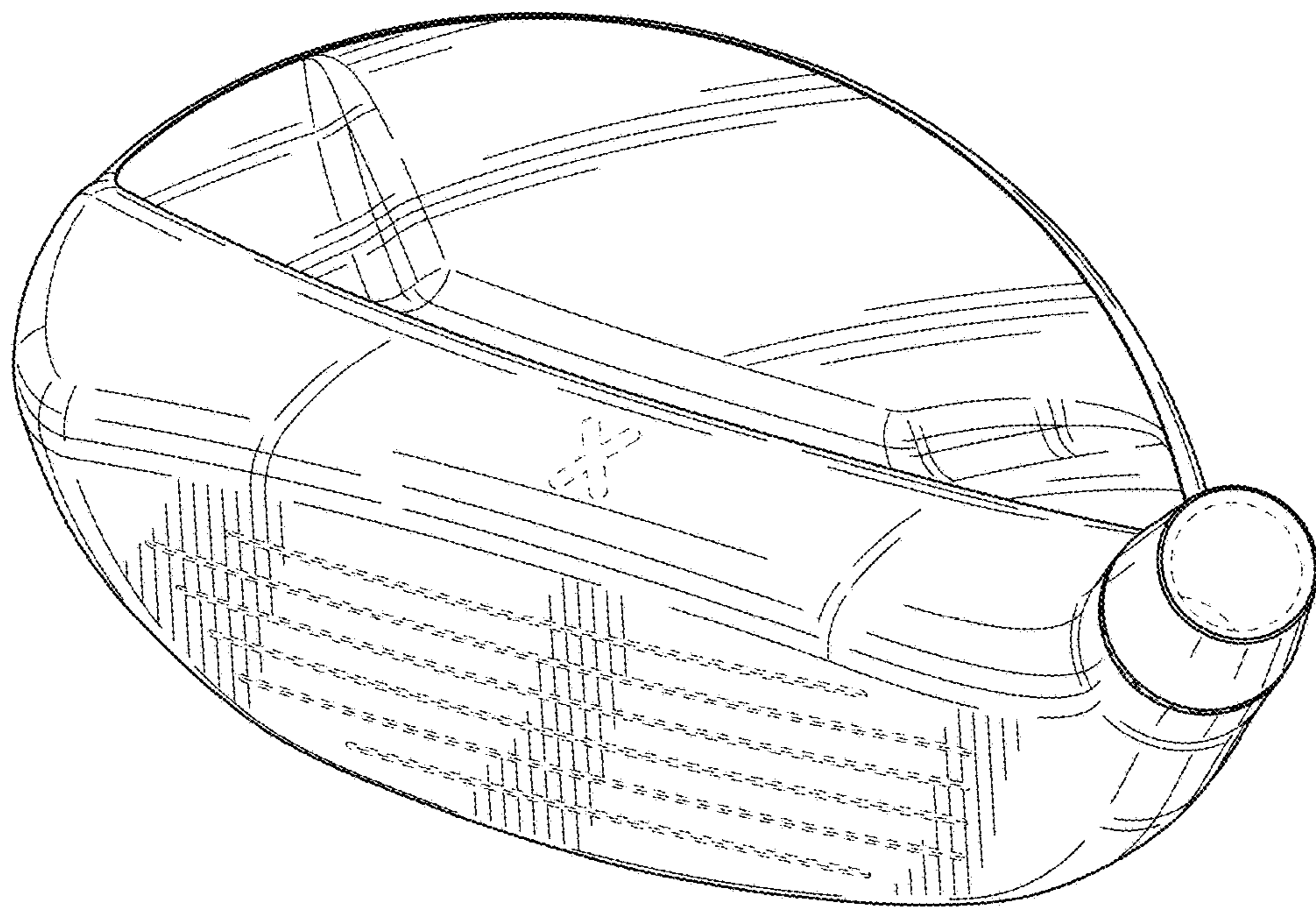

FIG. 41

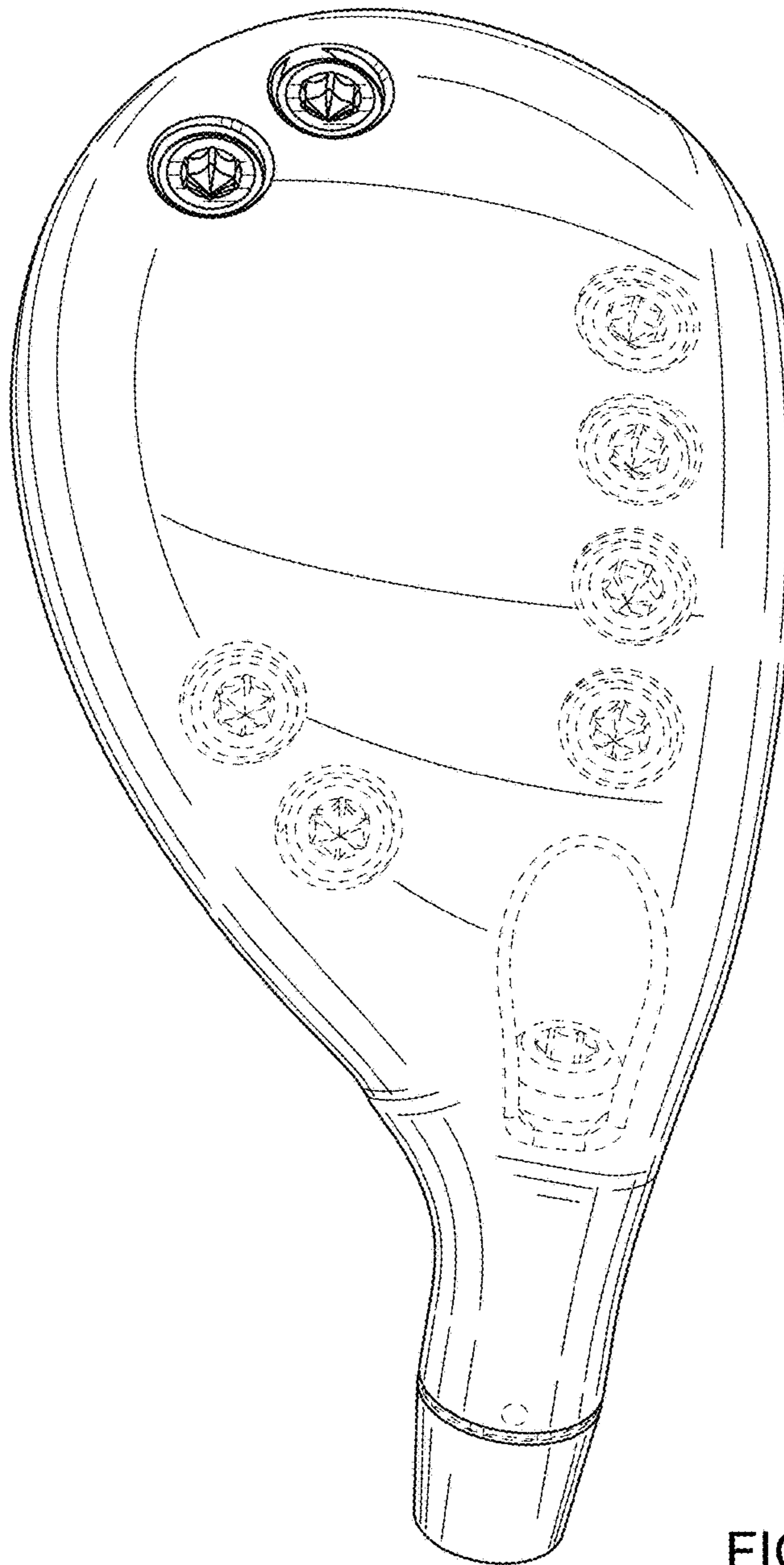

FIG. 42

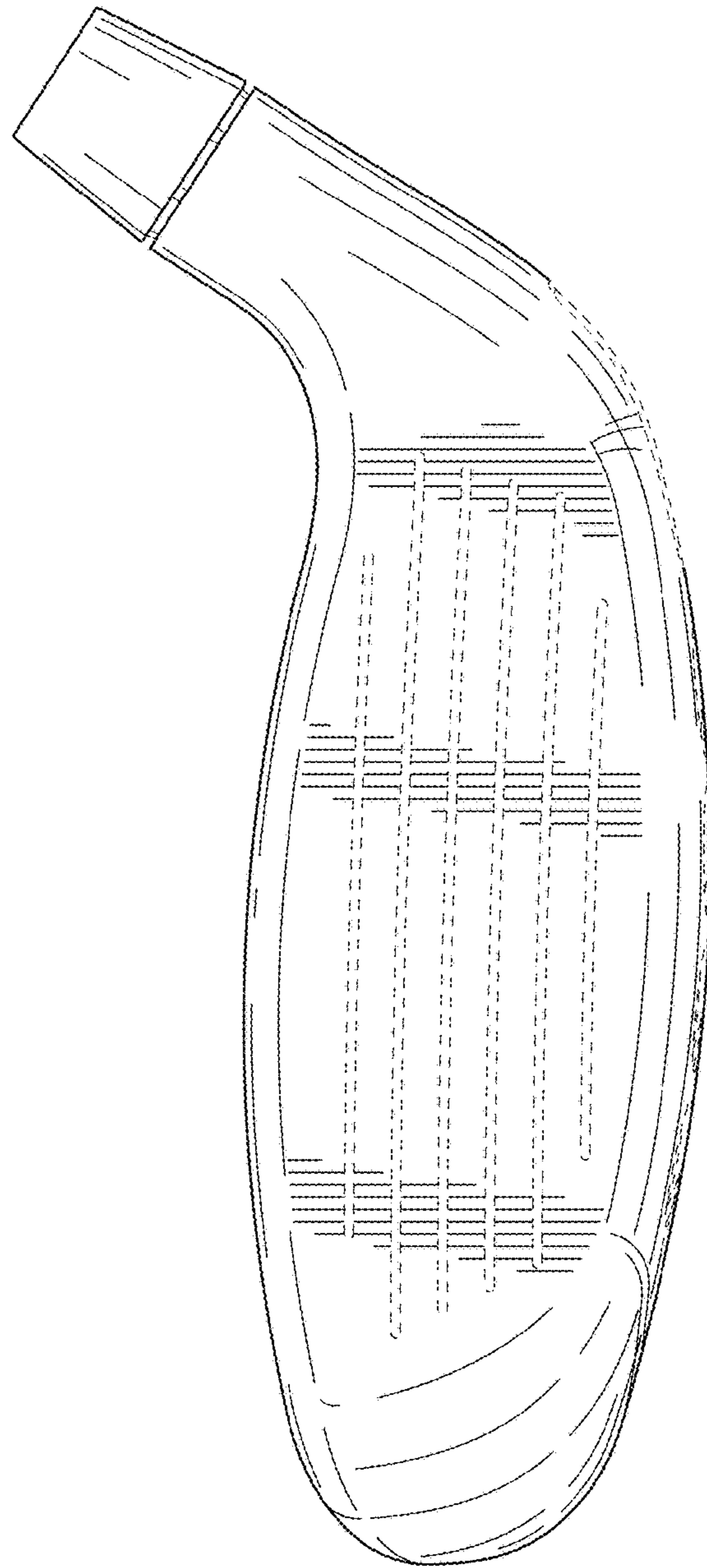

FIG. 43

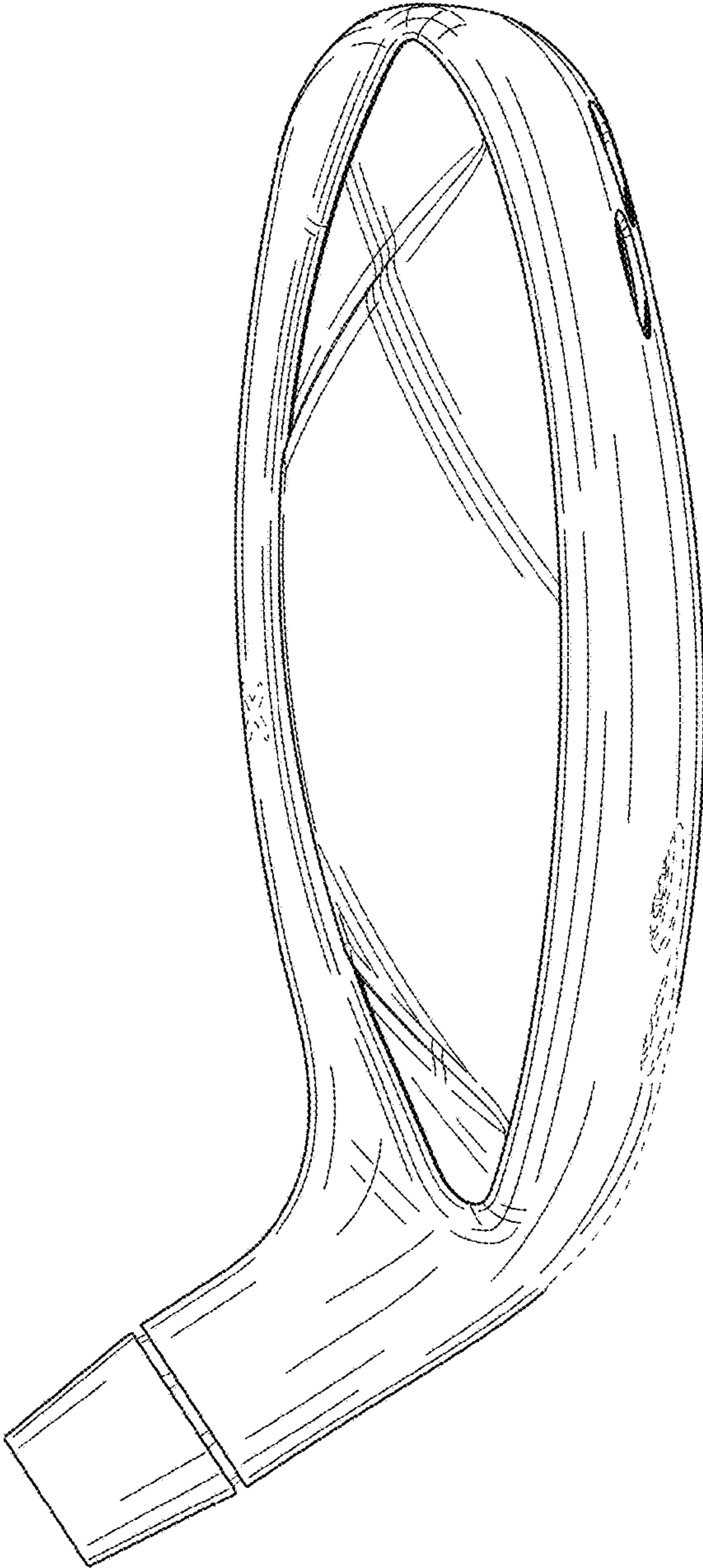

FIG. 44

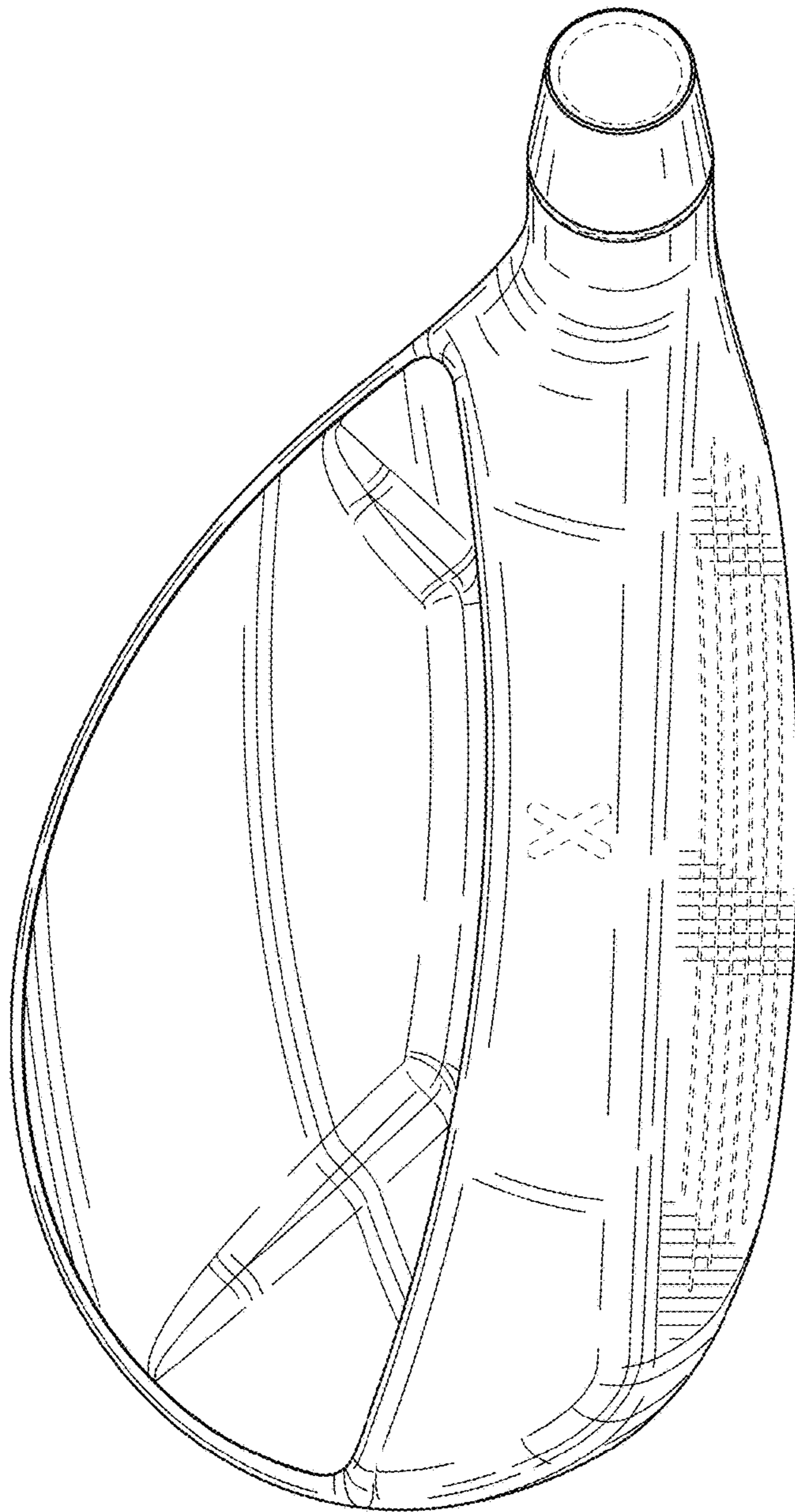

FIG. 45

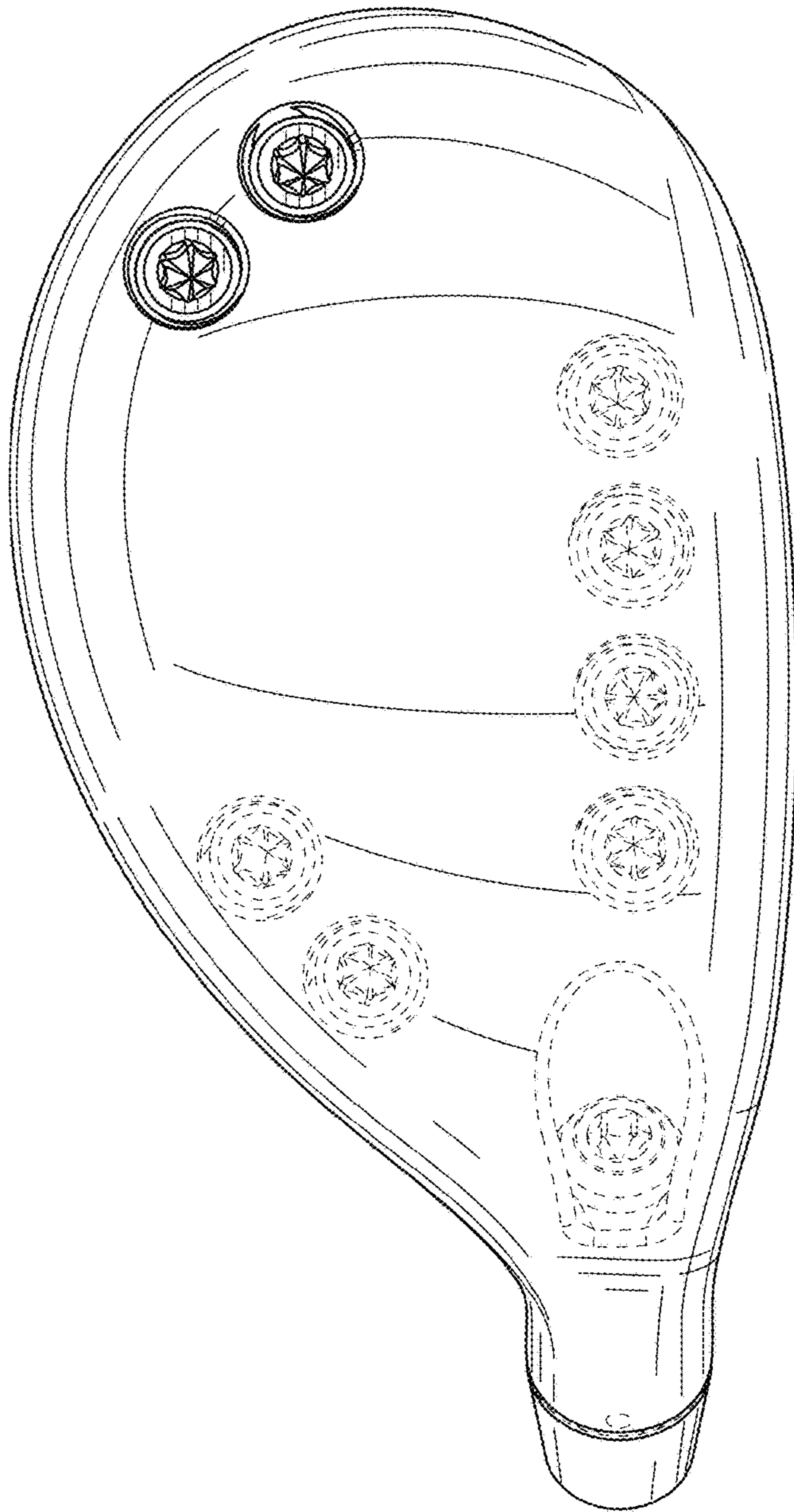

FIG. 46

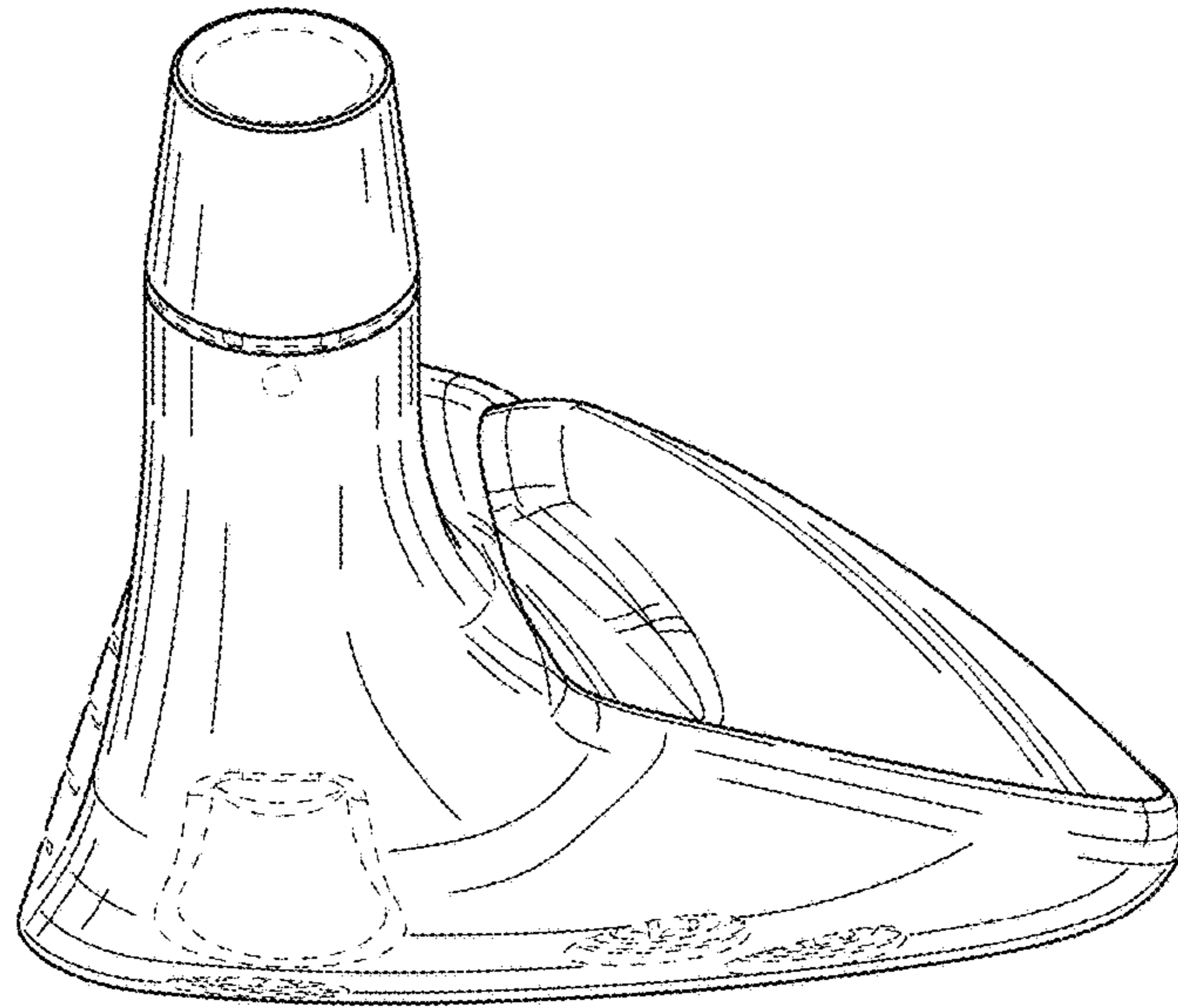

FIG. 47

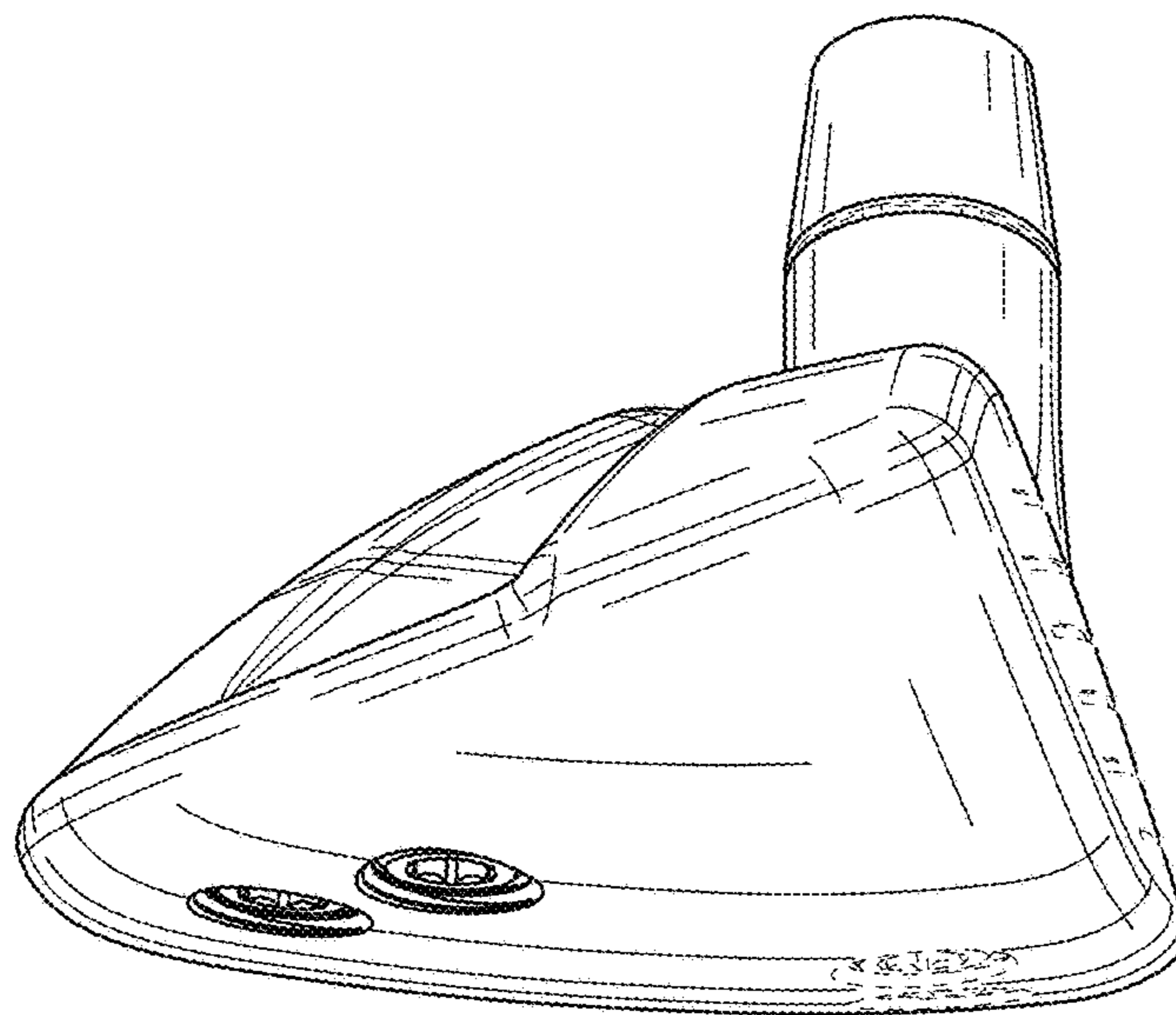

FIG. 48

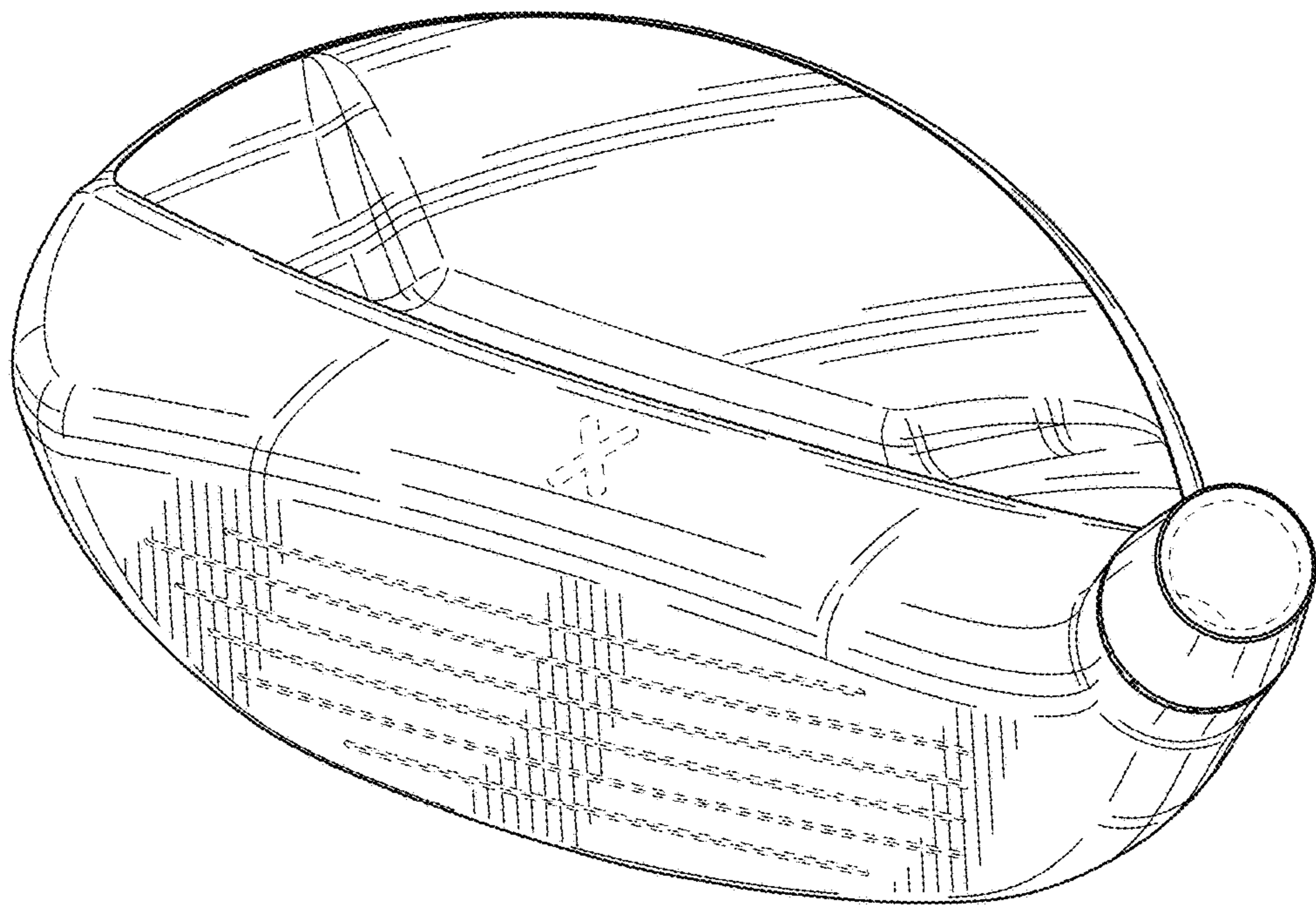

FIG. 49

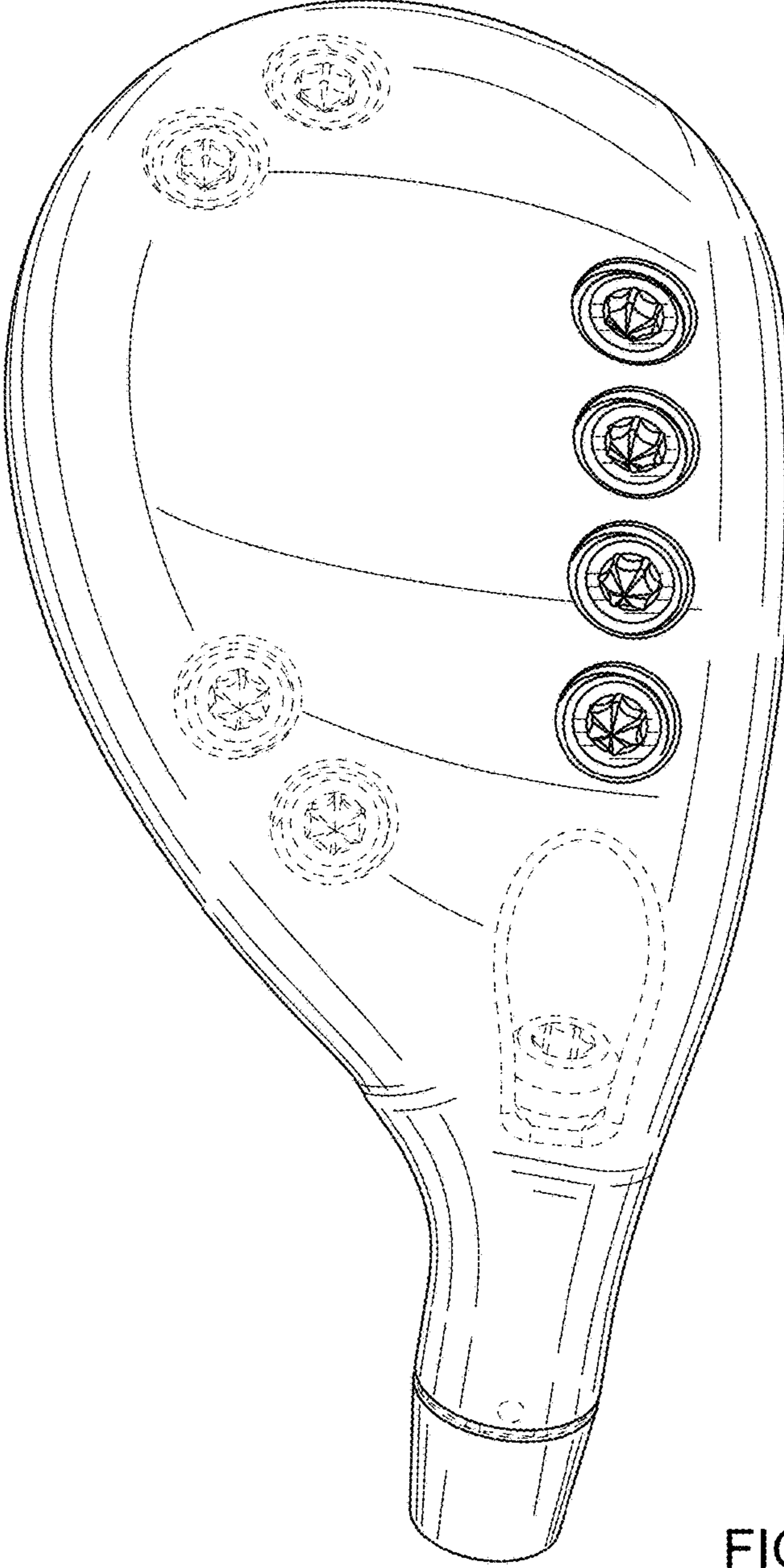

FIG. 50

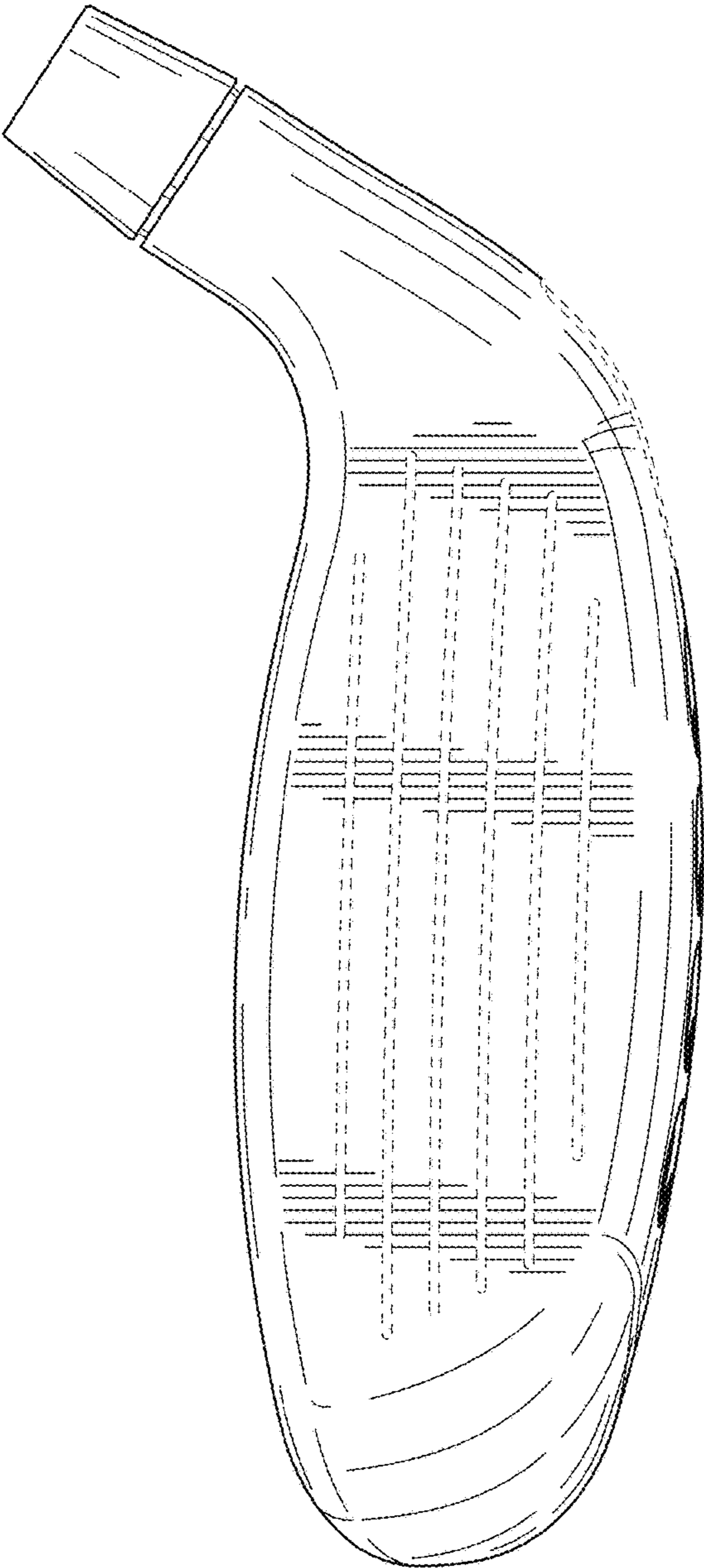

FIG. 51

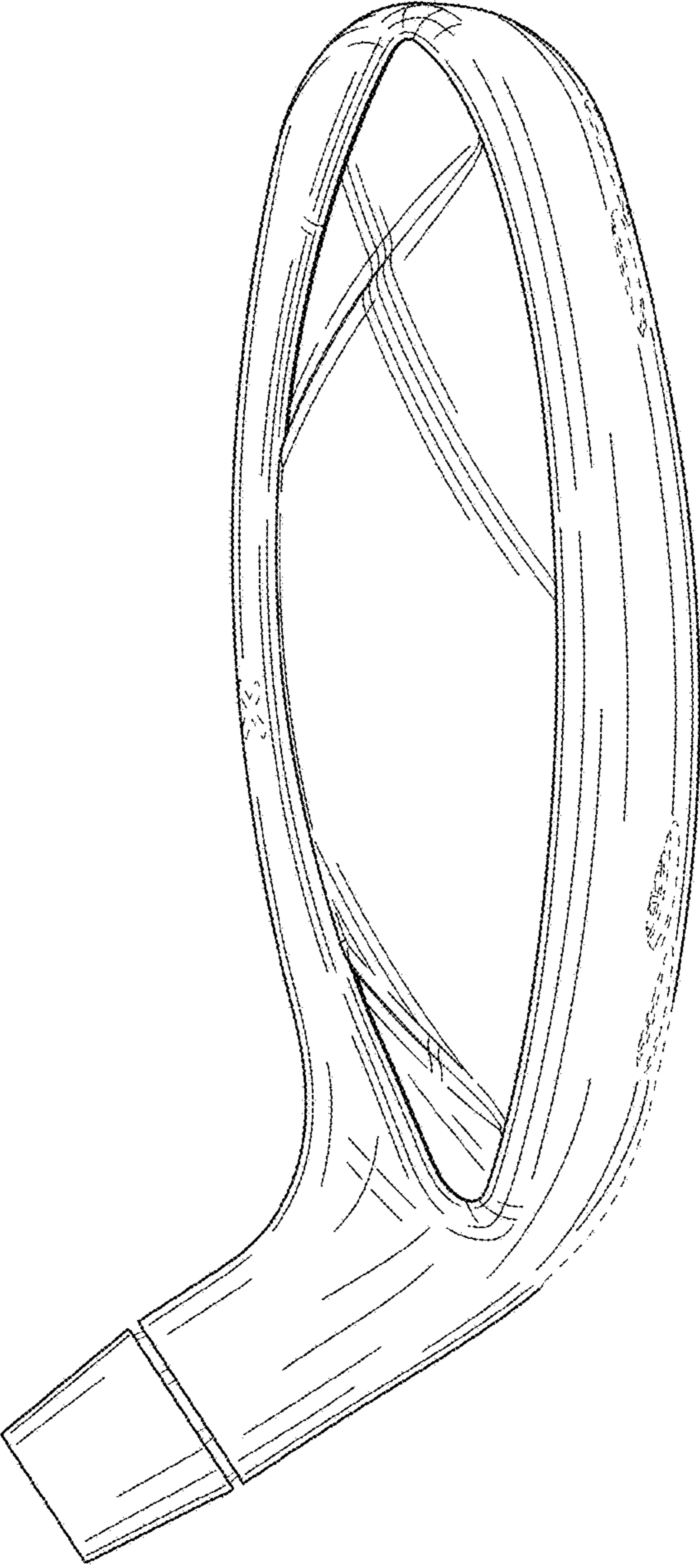

FIG. 52

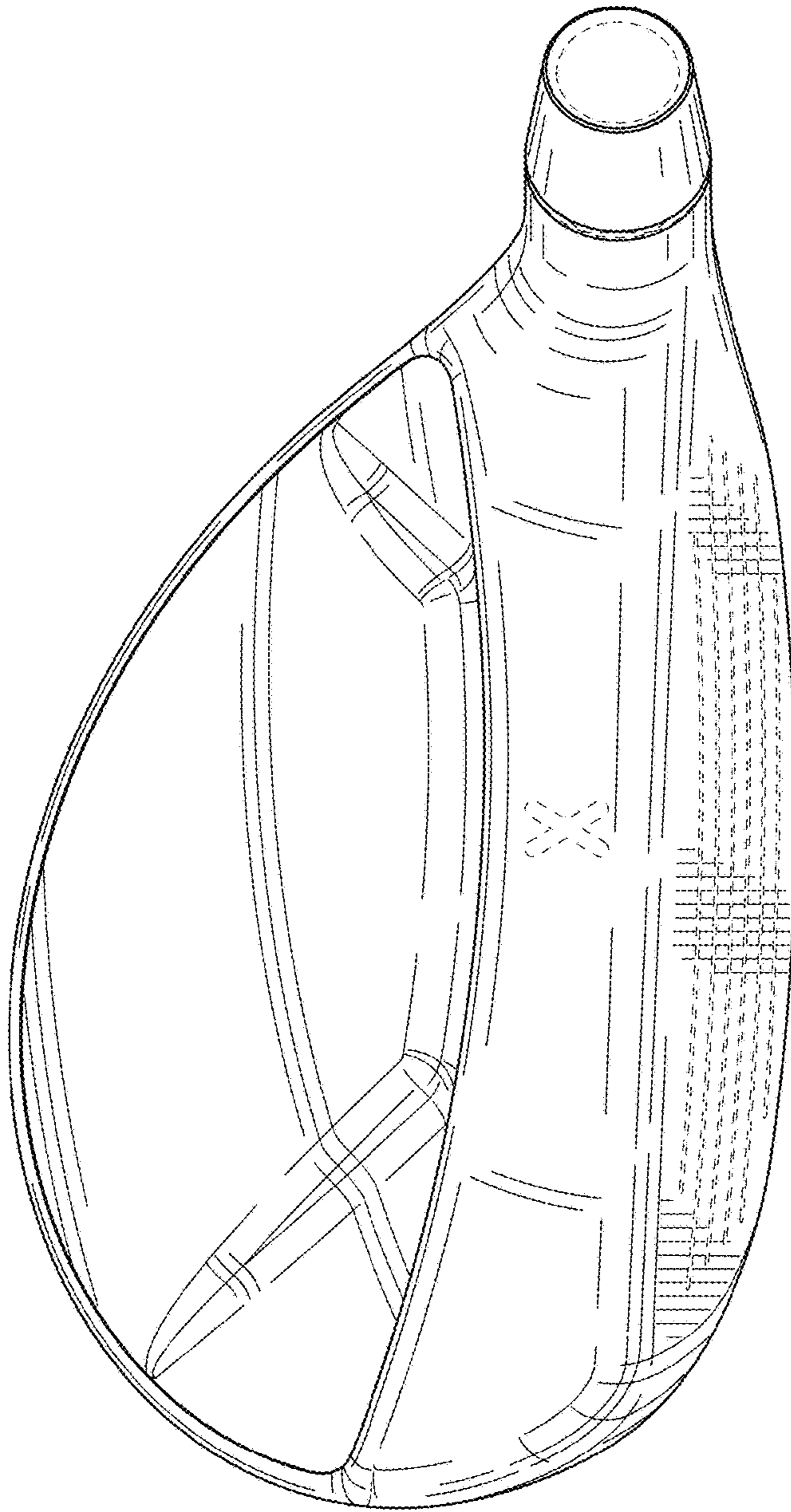

FIG. 53

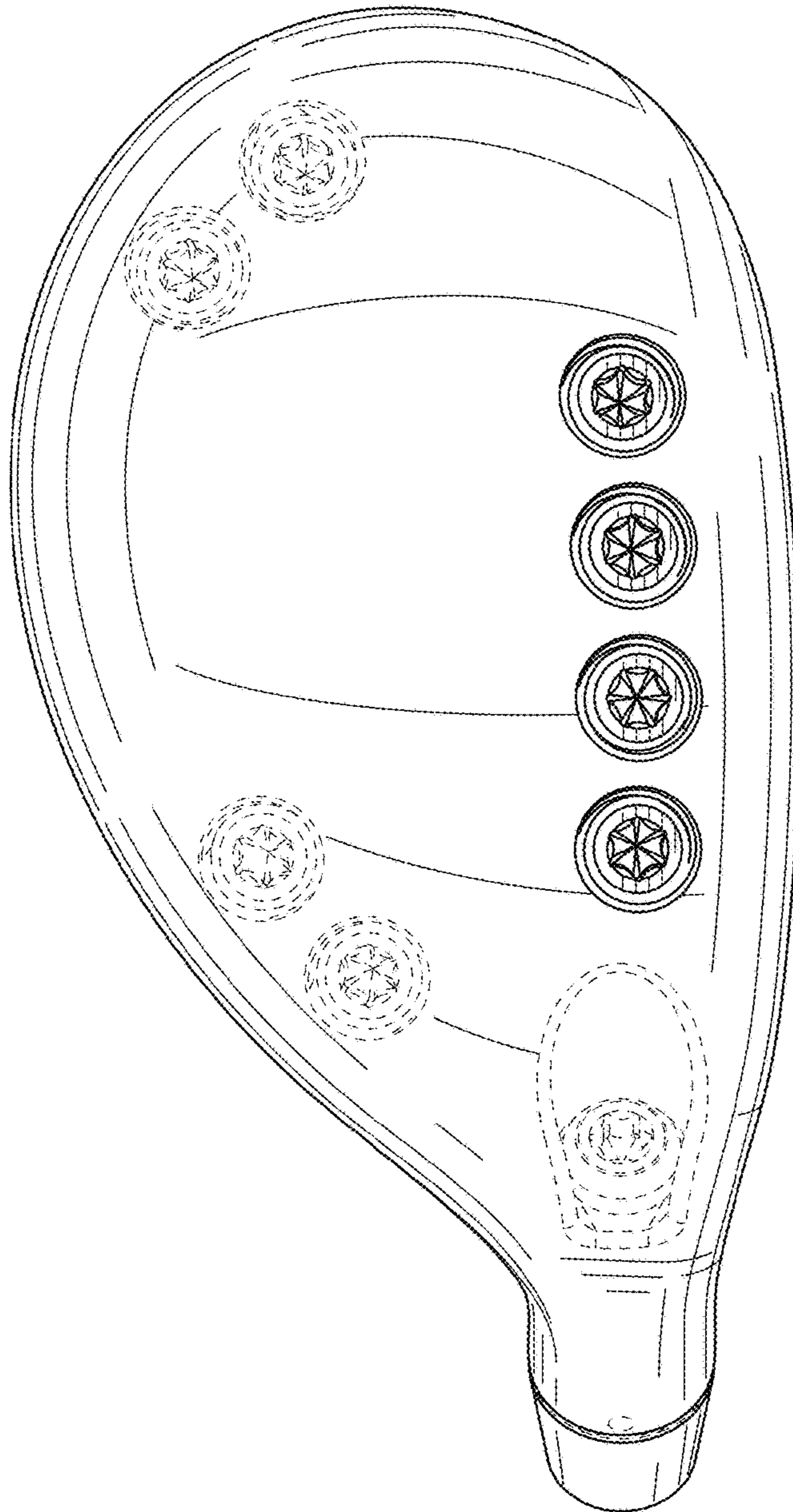

FIG. 54

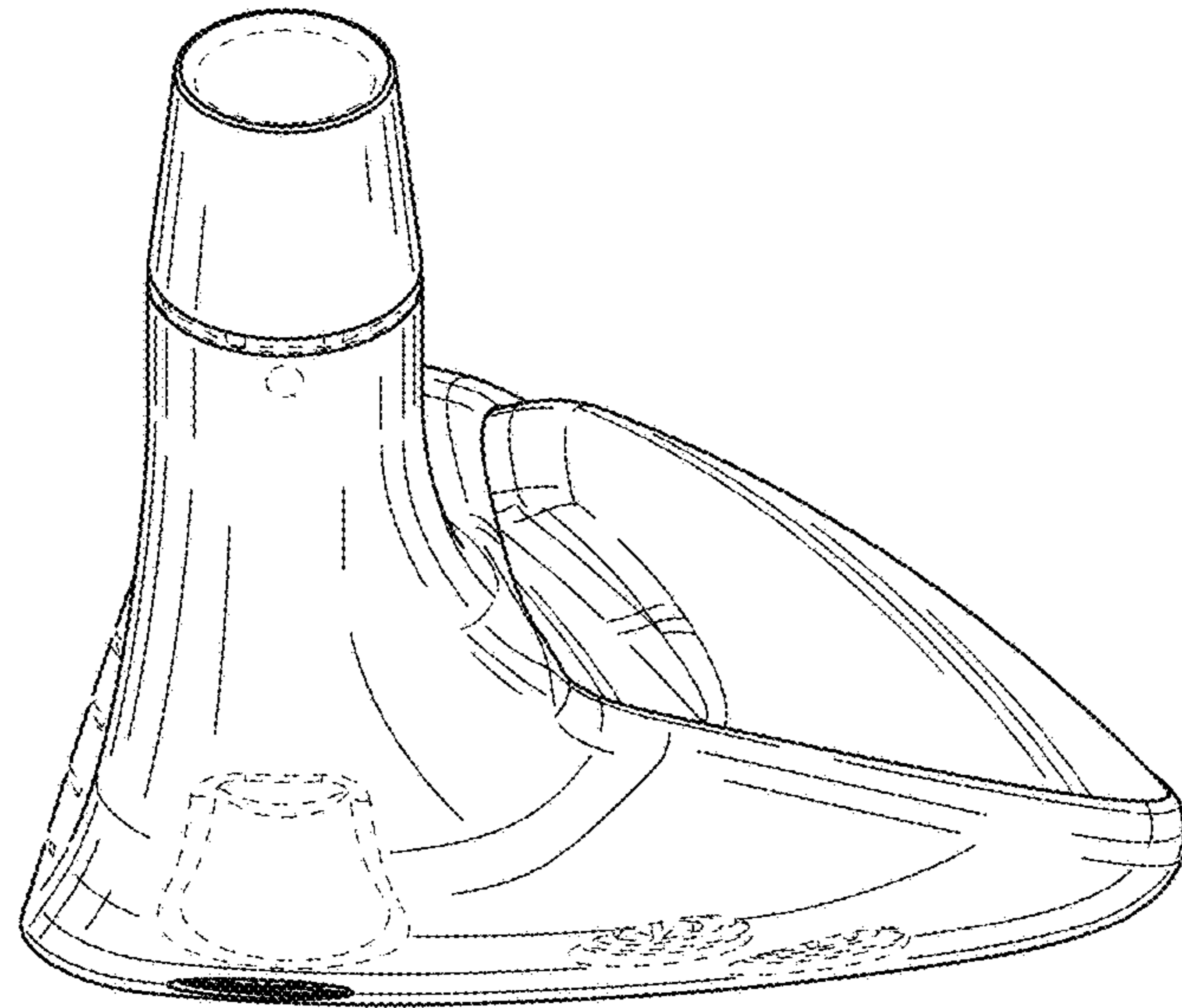

FIG. 55

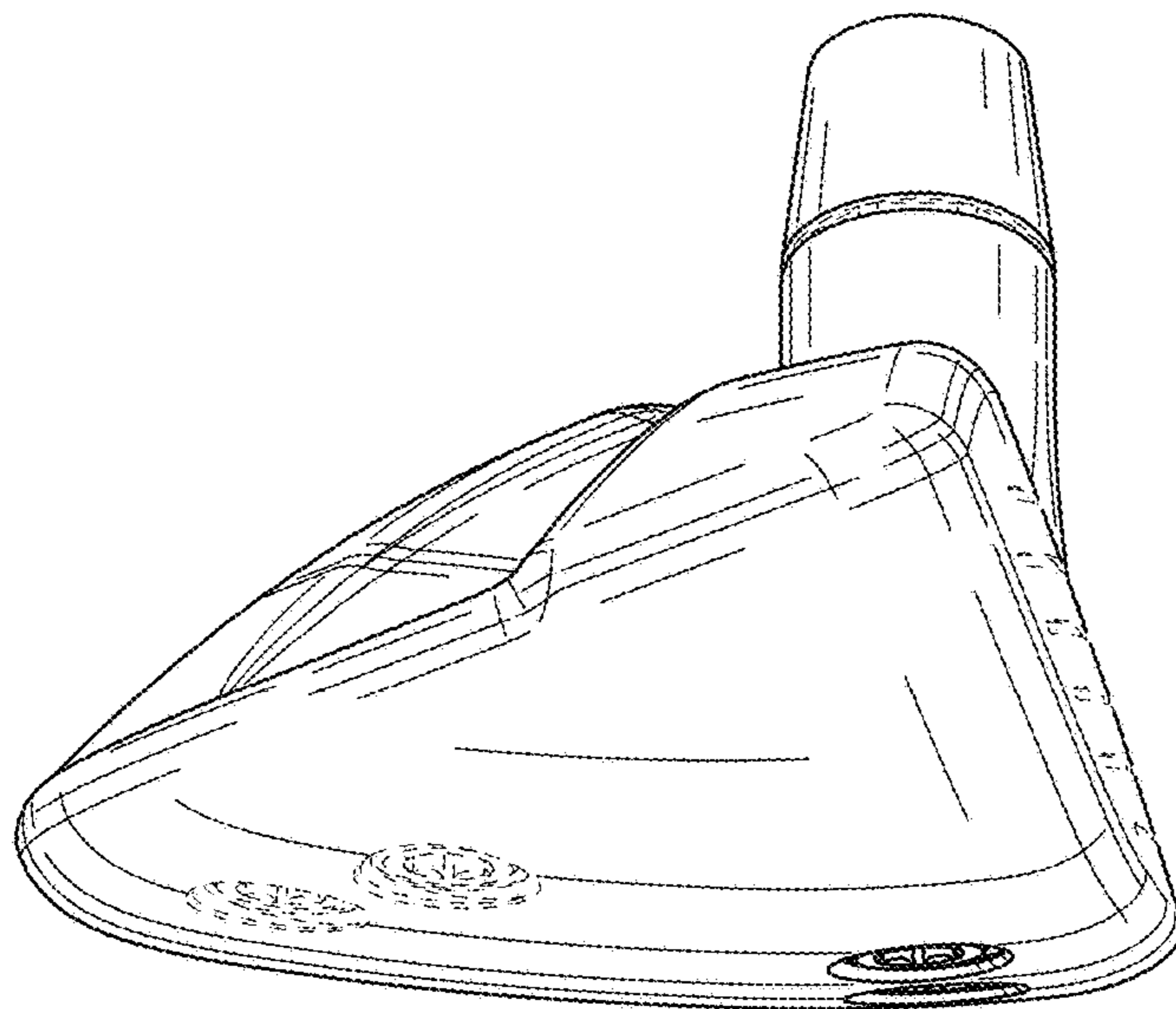

FIG. 56

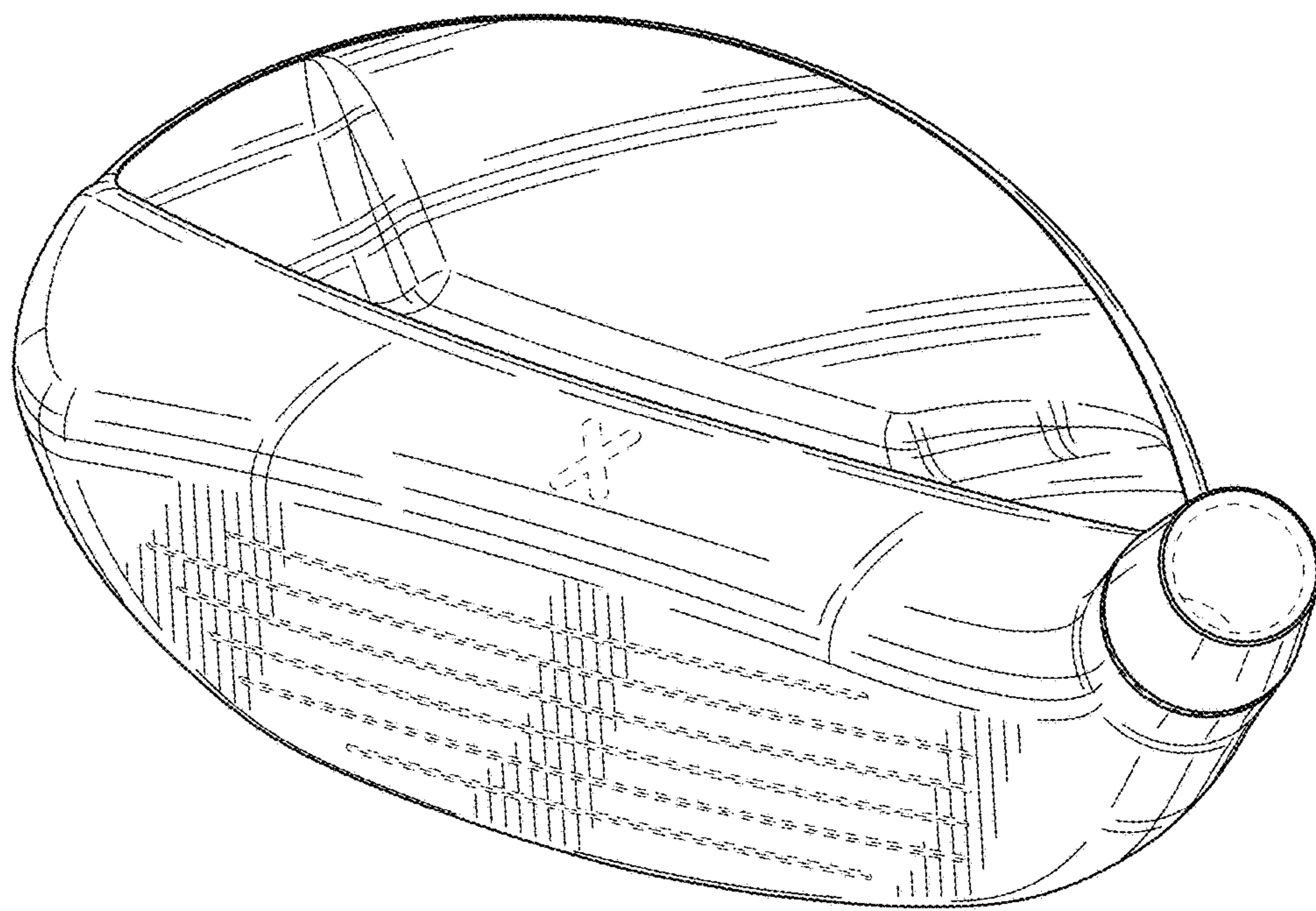

FIG. 57

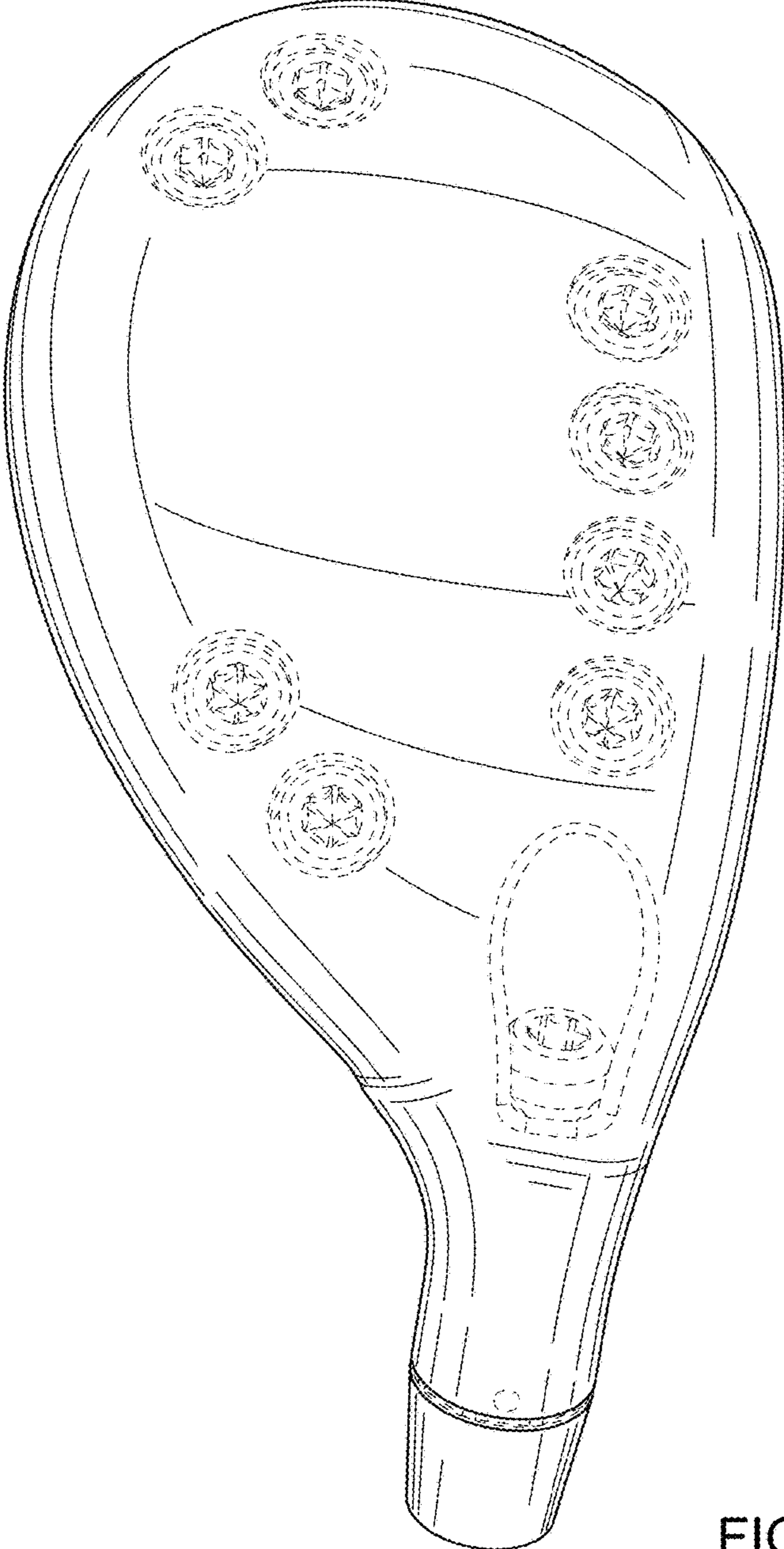

FIG. 58

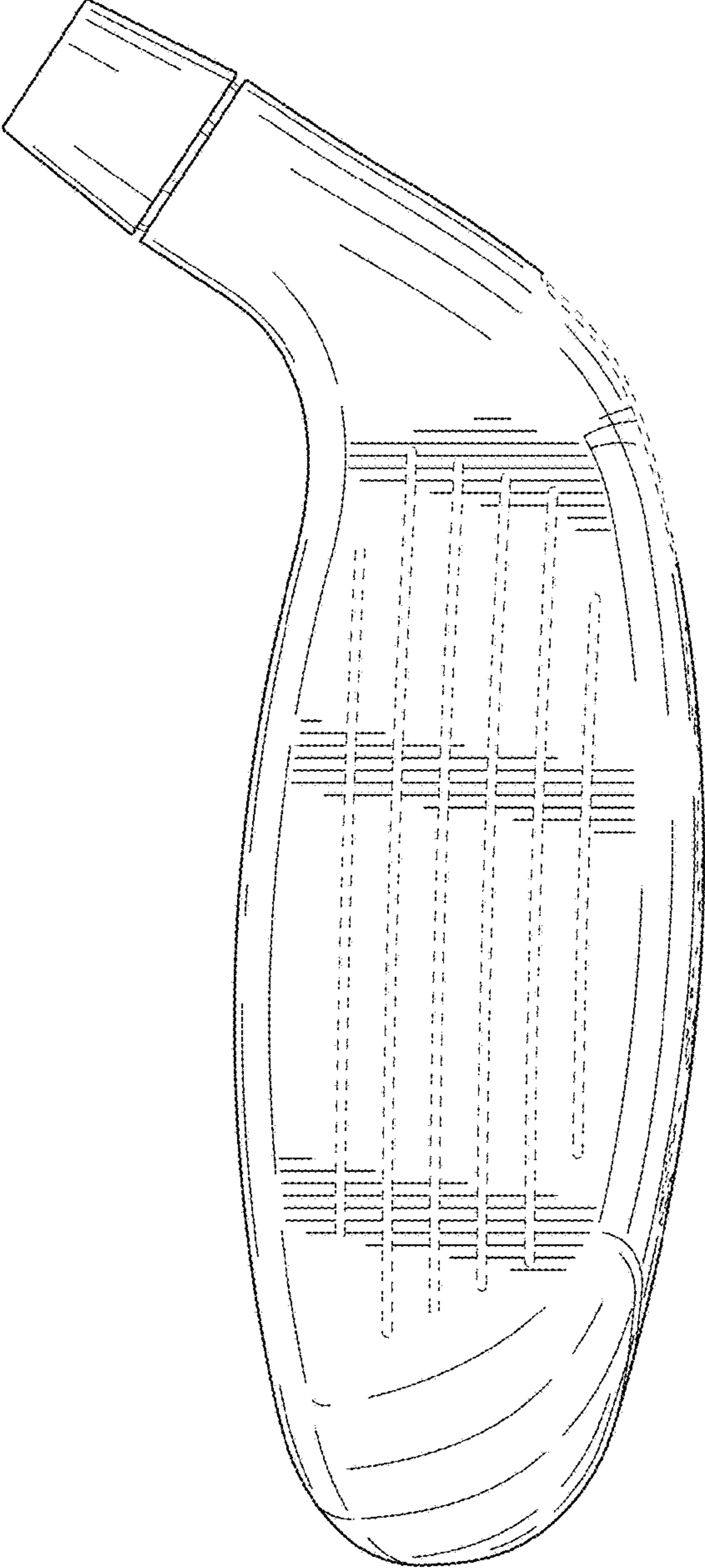

FIG. 59

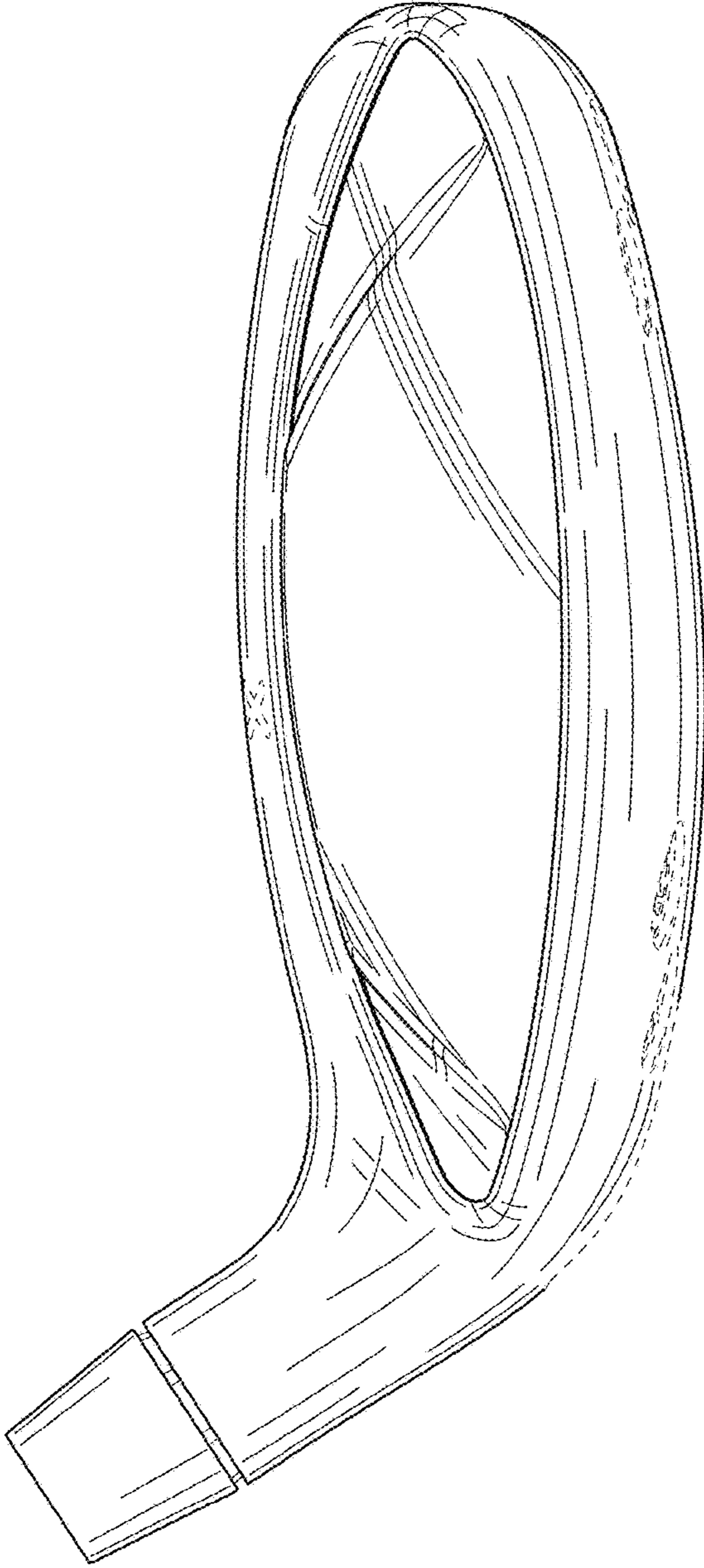

FIG. 60

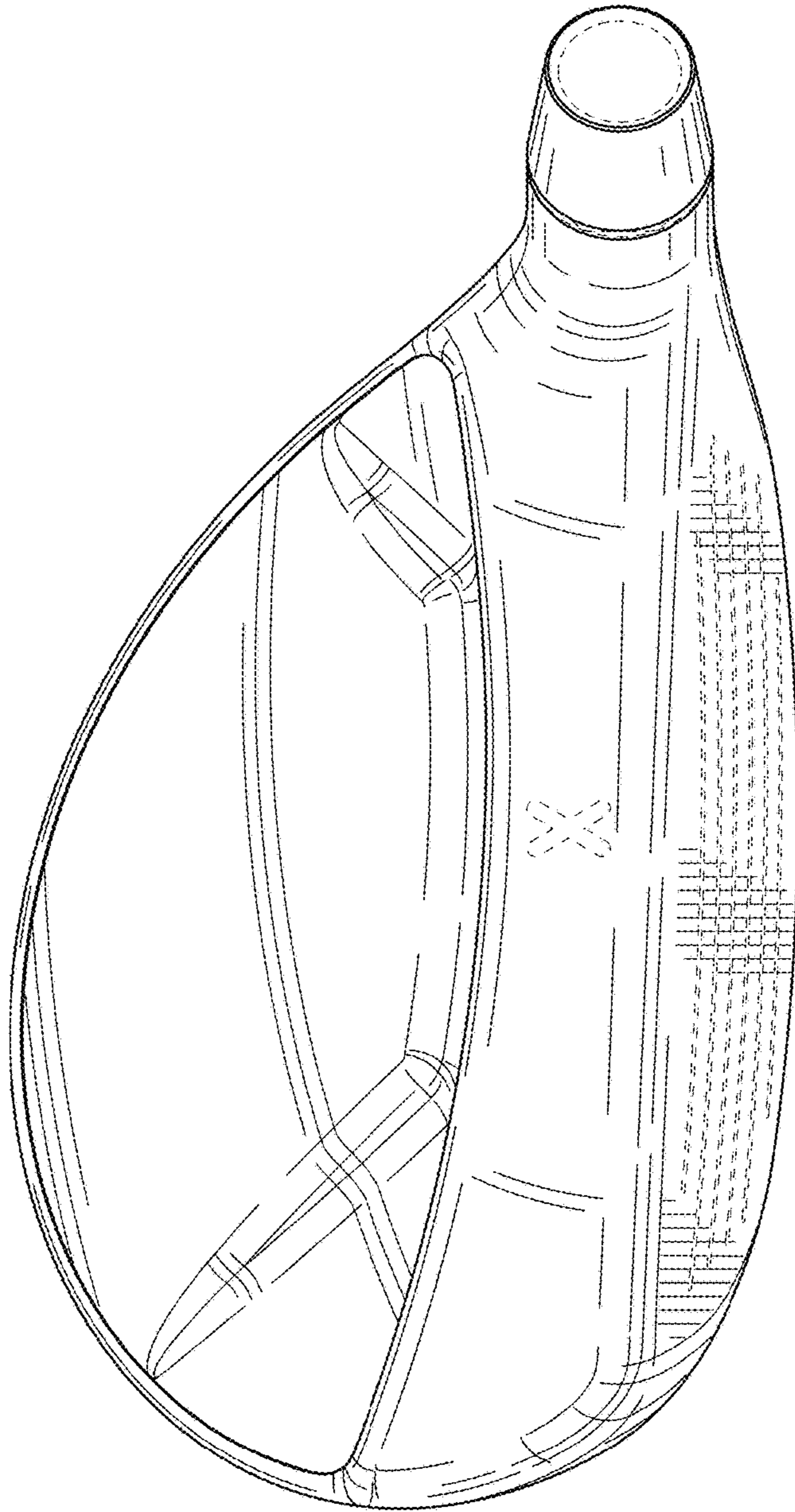

FIG. 61

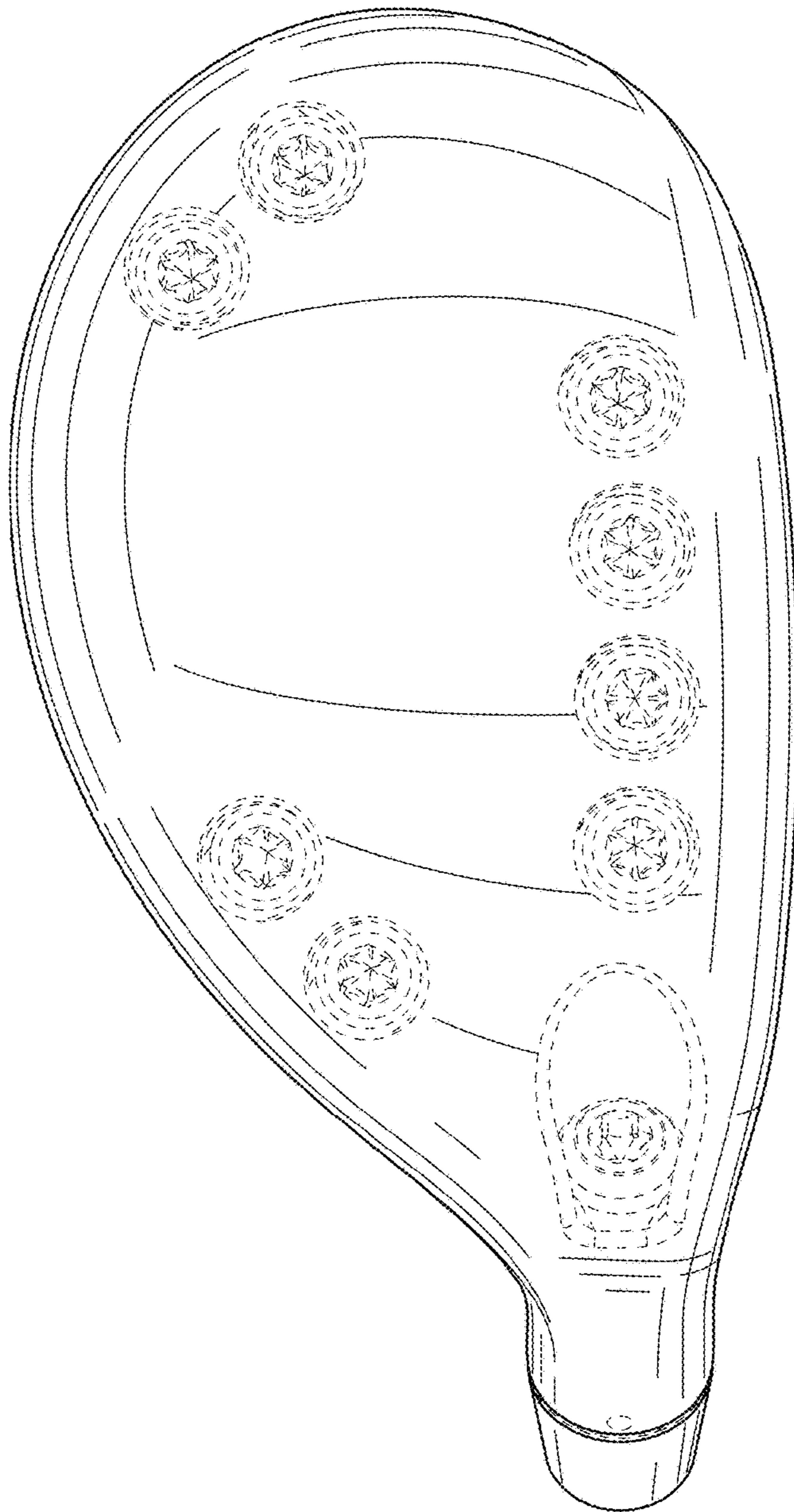

FIG. 62

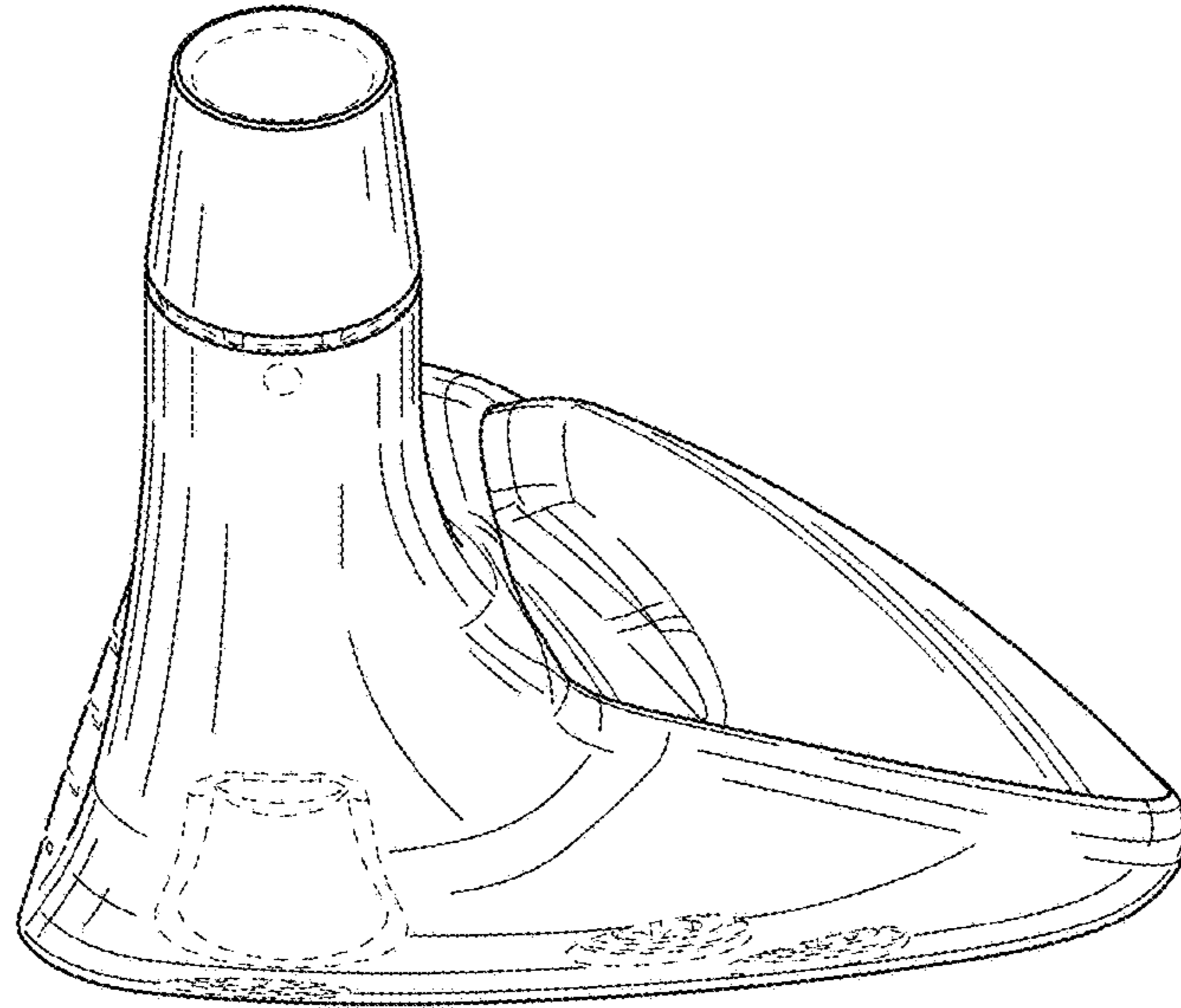

FIG. 63

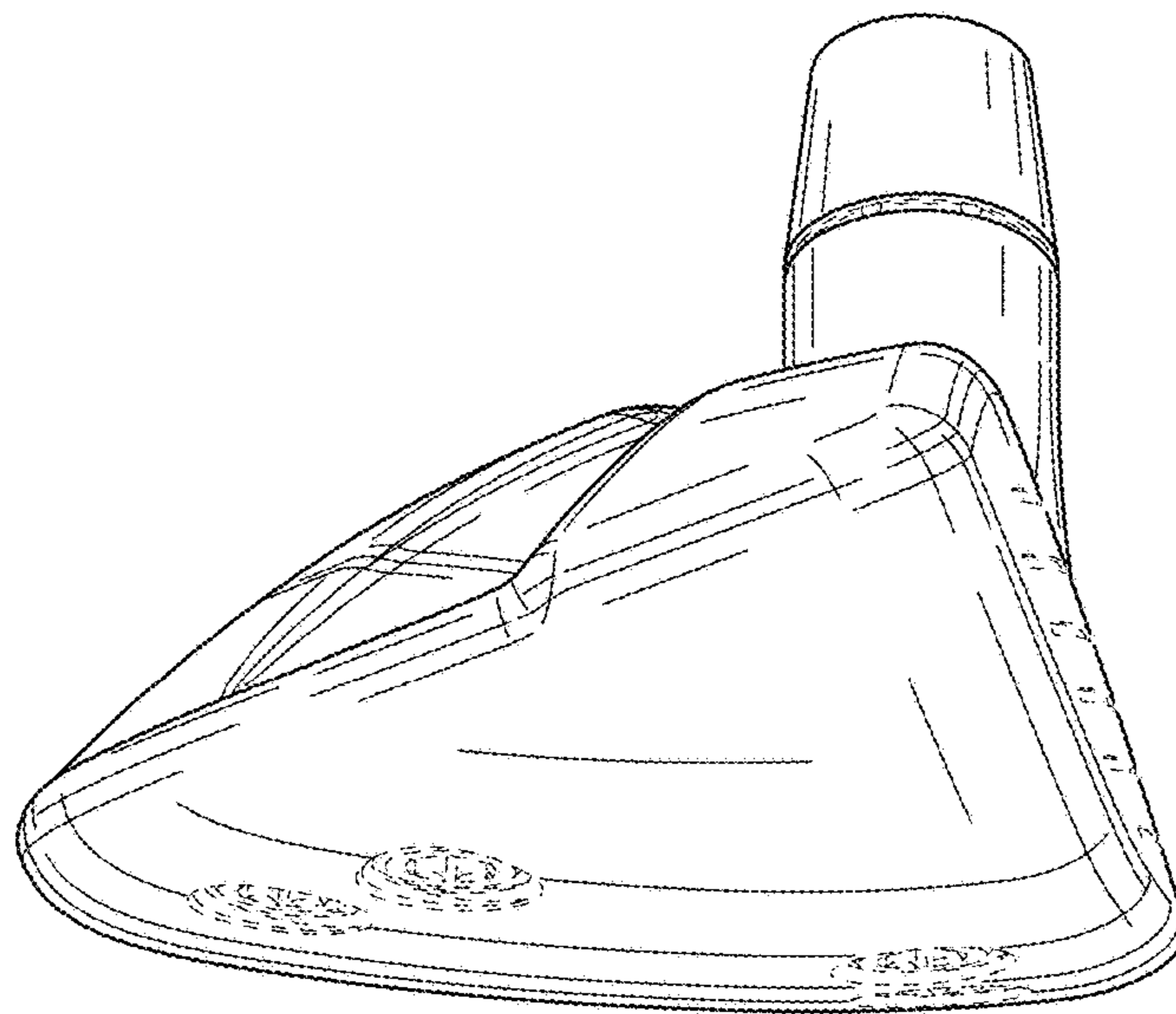

FIG. 64