



US00D852283S

(12) **United States Design Patent**
Matejczyk

(10) **Patent No.:** **US D852,283 S**
(45) **Date of Patent:** **** Jun. 25, 2019**

(54) **CHAIN LINK COMBINATION**

(71) Applicant: **Martine Blair Matejczyk**, Oakland, CA (US)

(72) Inventor: **Martine Blair Matejczyk**, Oakland, CA (US)

(**) Term: **15 Years**

(21) Appl. No.: **29/505,543**

(22) Filed: **Dec. 15, 2015**

(51) **LOC (11) Cl.** **21-01**

(52) **U.S. Cl.**
USPC **D21/468**

(58) **Field of Classification Search**
USPC D21/406, 468, 684, 694, 734, 736, 753, D21/756-759, 770, 771, 826, 789-795; D8/304, 356, 394, 395, 396; D3/15, 229; 473/201, 206, 215-218, 300-303, 551, 473/553
CPC B60C 7/14; B60B 9/26; A63B 69/36
See application file for complete search history.

(56) **References Cited**

U.S. PATENT DOCUMENTS

| | | | | | |
|-----------|-----|---------|-----------|-------|-------------|
| 1,226,397 | A * | 5/1917 | Smith | | B60C 9/26 |
| | | | | | 152/72 |
| 1,415,994 | A * | 5/1922 | Collins | | B60C 7/14 |
| | | | | | 152/261 |
| 1,630,920 | A * | 5/1927 | Balogh | | B60C 9/26 |
| | | | | | 152/37 |
| 3,493,027 | A * | 2/1970 | Dewhirst | | B60C 7/14 |
| | | | | | 152/11 |
| D234,246 | S * | 2/1975 | Martini | | D8/395 |
| D278,920 | S * | 5/1985 | Wichman | | D11/42 |
| D312,035 | S * | 11/1990 | Carlson | | D8/349 |
| D372,882 | S * | 8/1996 | Goldman | | D11/40 |
| D508,397 | S * | 8/2005 | Volk | | A01K 11/004 |
| | | | | | D8/395 |
| D535,550 | S * | 1/2007 | Silberman | | D8/356 |
| D596,747 | S * | 7/2009 | Freeland | | D24/199 |

| | | | | | |
|----------|-----|---------|---------|-------|---------|
| D626,613 | S * | 11/2010 | Ru | | D21/756 |
| D782,589 | S * | 3/2017 | Burdick | | D21/756 |
| D809,614 | S * | 2/2018 | Chiu | | D21/684 |

OTHER PUBLICATIONS

“Wrought Iron Rosette”, posted Oct. 25, 2010 [online], [retrieved Apr. 23, 2018]. Retrieved from internet, <http://www.traderscity.com/board/products-1/offers-to-sell-and-export-1/wrought-iron-rosette-212873/>.*

“Model A Ford Pickup Bed Tailgate Chain Top Link-Steel”, posted dte unavailable [online], [retrieved Apr. 23, 2018]. Retrieved from internet, https://www.macsauparts.com/ford_model_a/model-a-ford-pickup-bed-tailgate-chain-top-link-steel.html.*

* cited by examiner

Primary Examiner — Barbara Fox

Assistant Examiner — Mehri F Bajoul

(74) *Attorney, Agent, or Firm* — John H. Miller

(57) **CLAIM**

The ornamental design for a chain link combination, as shown and described.

DESCRIPTION

FIG. 1 is a perspective view of a chain link combination showing my new design in a first embodiment, showing four individual elements aligned.

FIG. 2 is a top plan view thereof.

FIG. 3 is a perspective view of the chain link combination of FIG. 1 in a different configuration.

FIG. 4 is a top plan view thereof.

FIG. 5 is a perspective view of the chain link combination in a second embodiment, showing 17 individual elements in a coiled configuration.

FIG. 6 is a front elevational view thereof.

FIG. 7 is a top plan view thereof; and,

FIG. 8 is a perspective view of the clip portion shown in FIGS. 1-7, shown separately to show aspects of the clip that are not visible when combined.

1 Claim, 4 Drawing Sheets

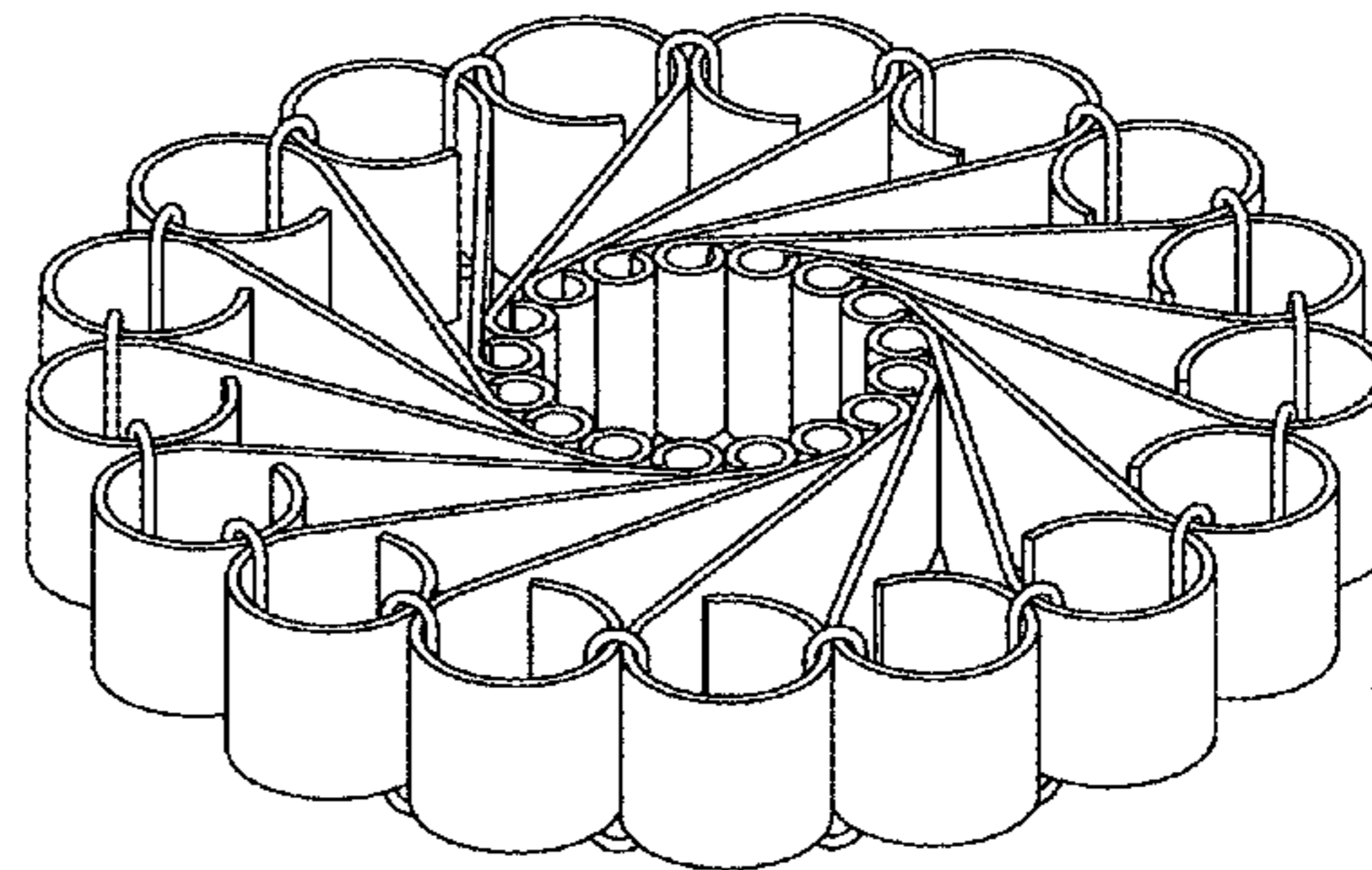
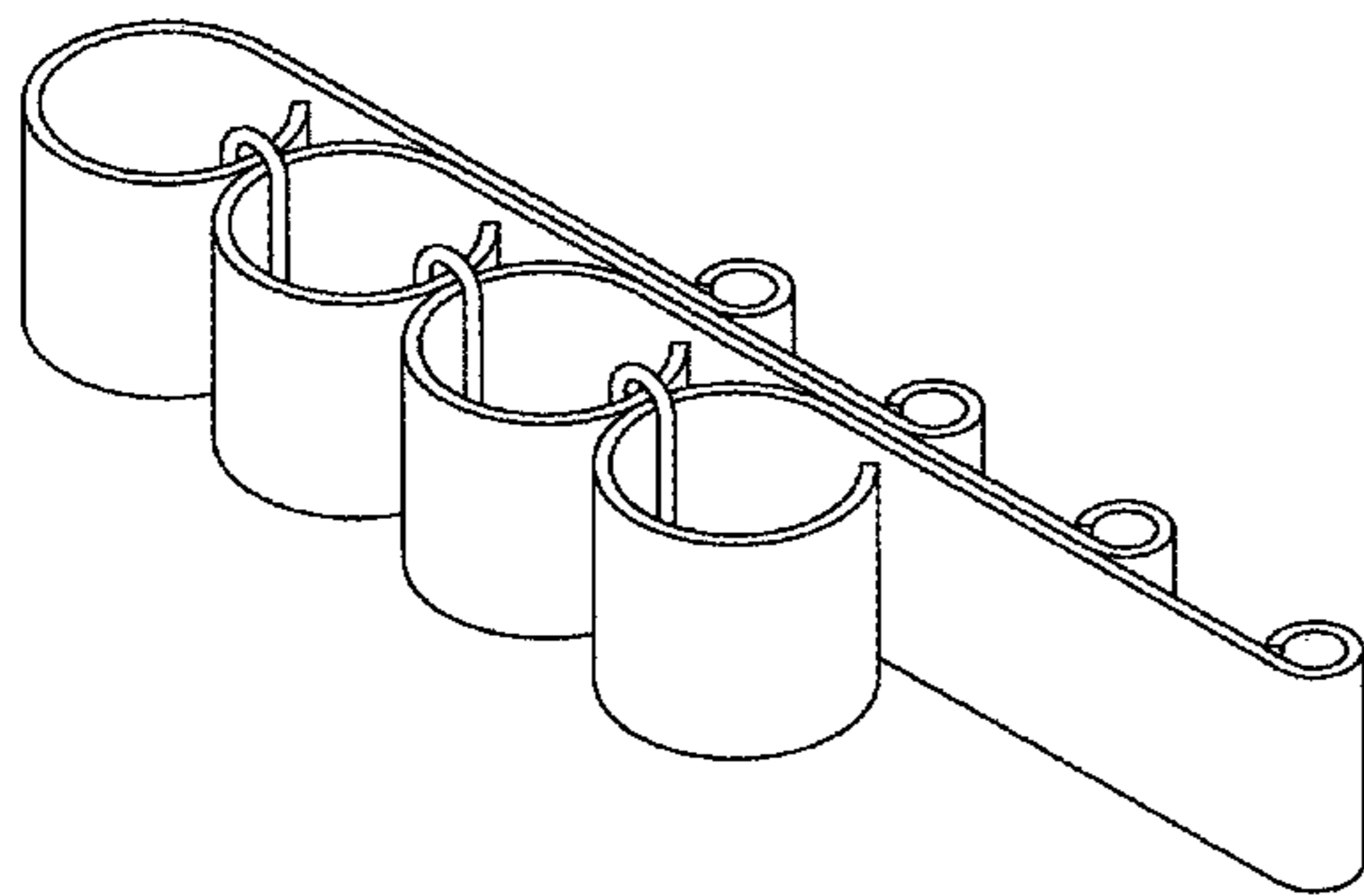

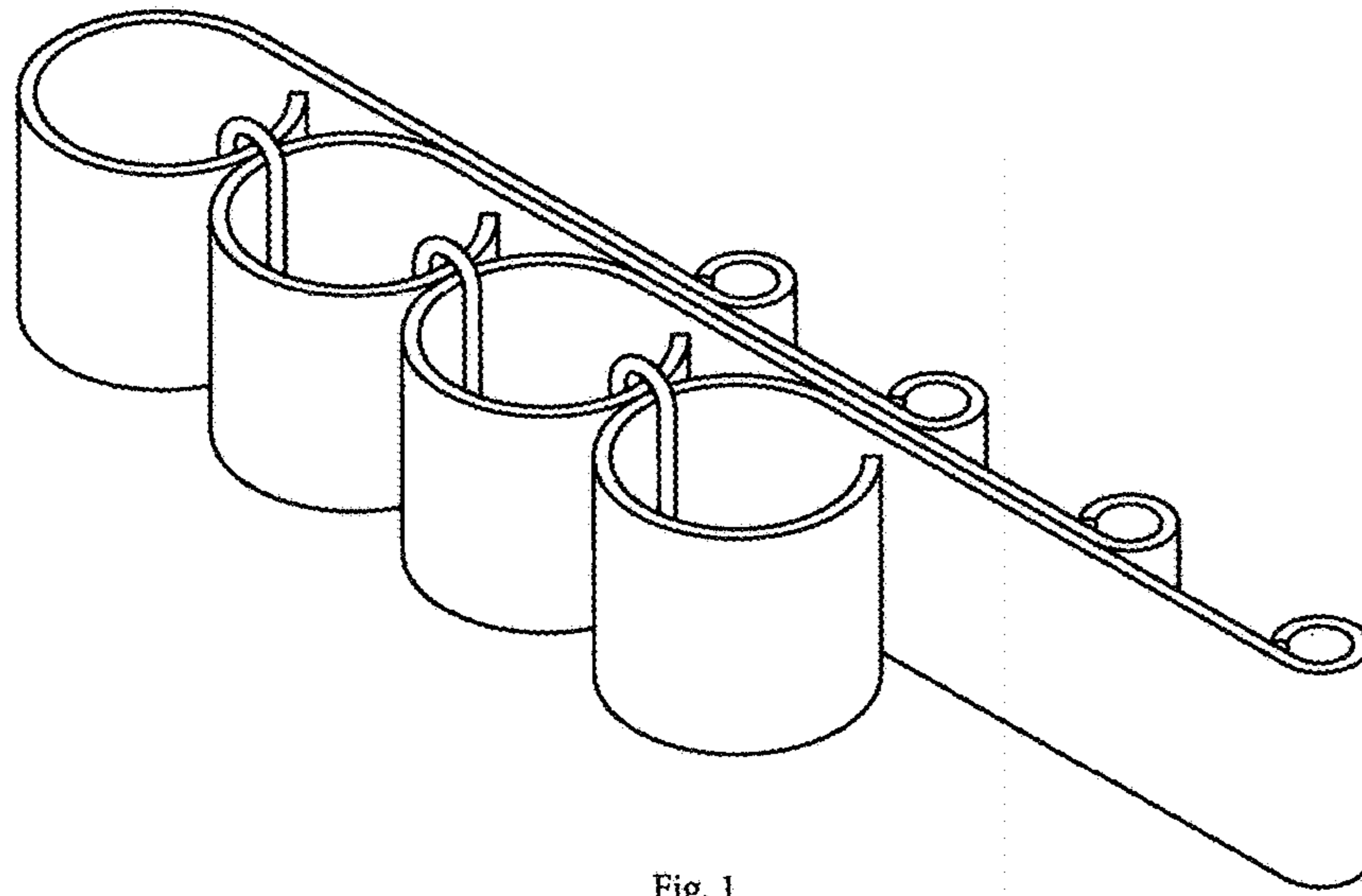

Fig. 1

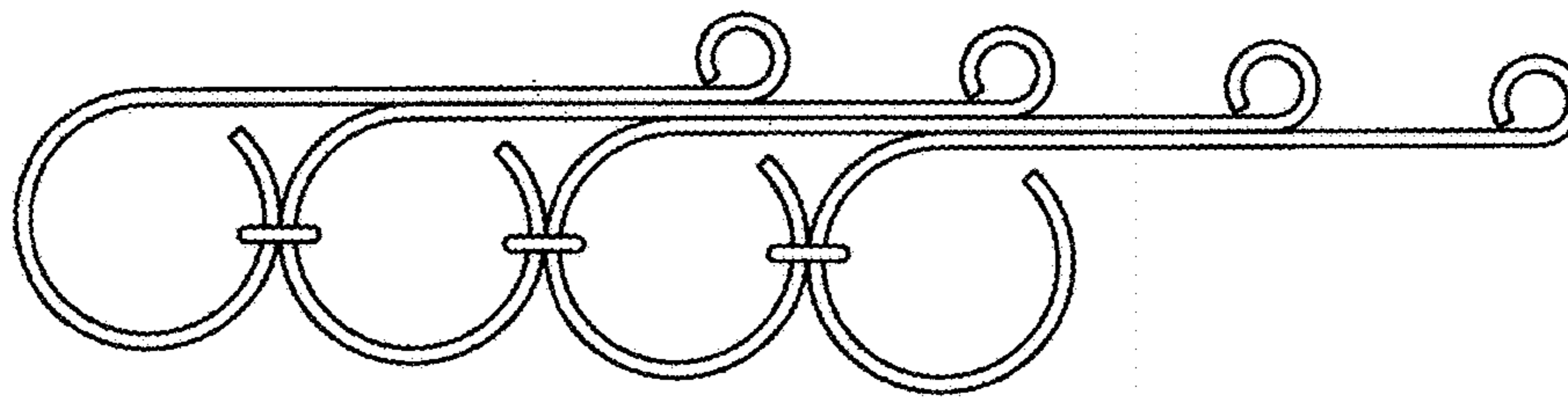

Fig. 2

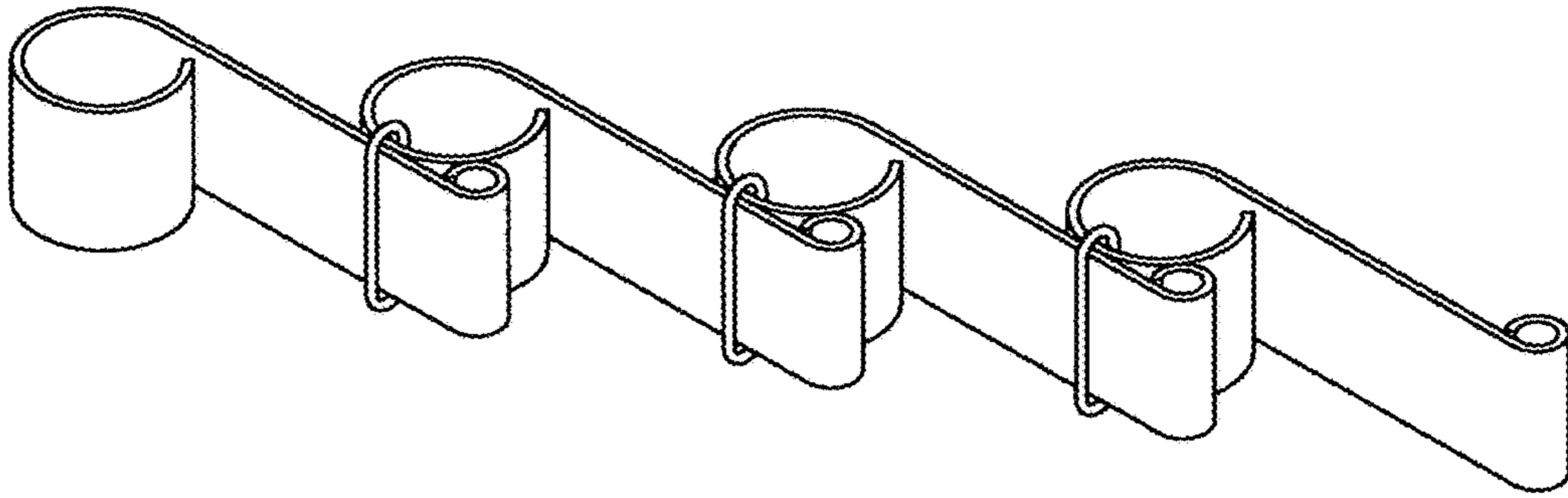

Fig. 3

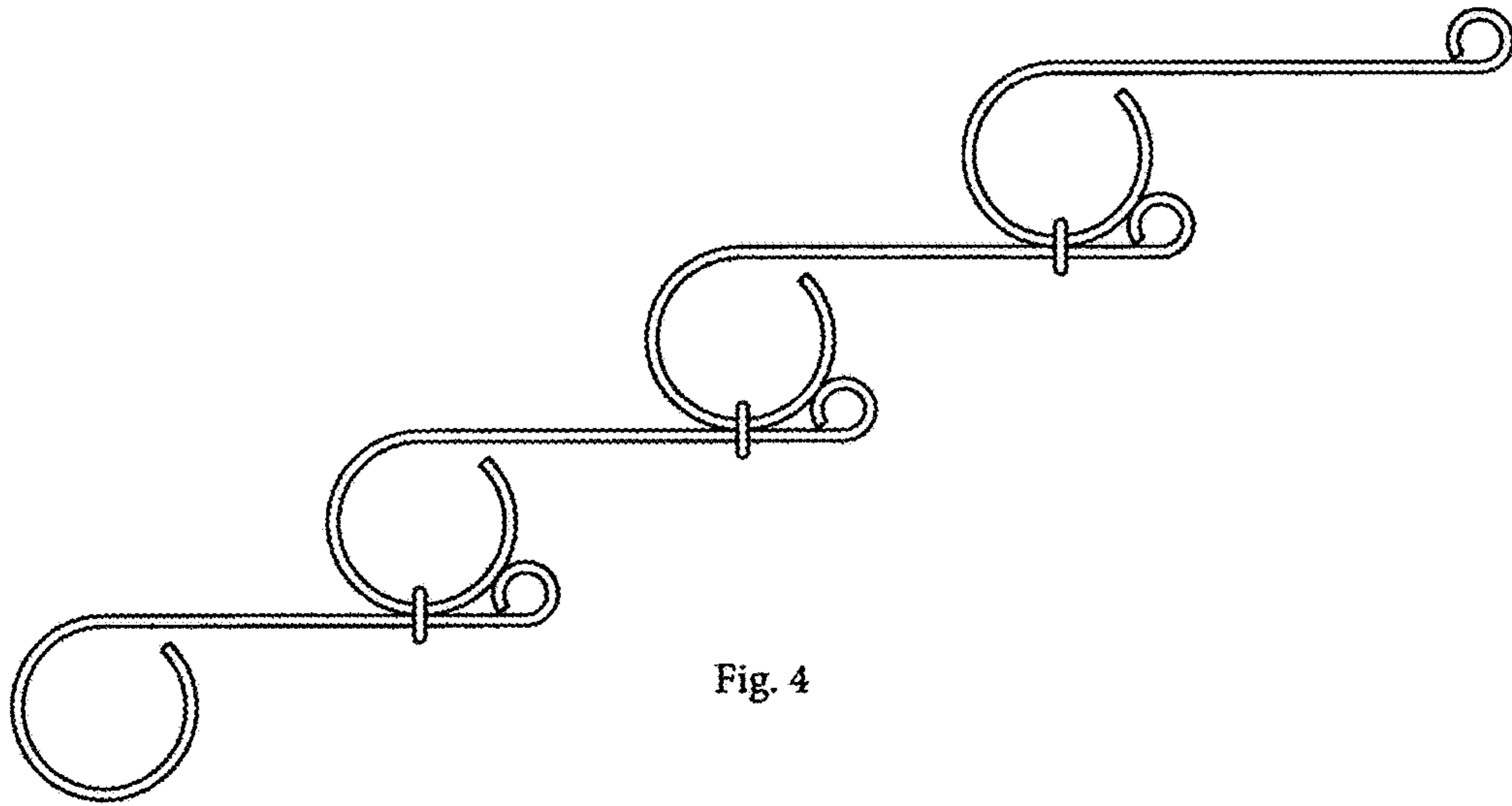

Fig. 4

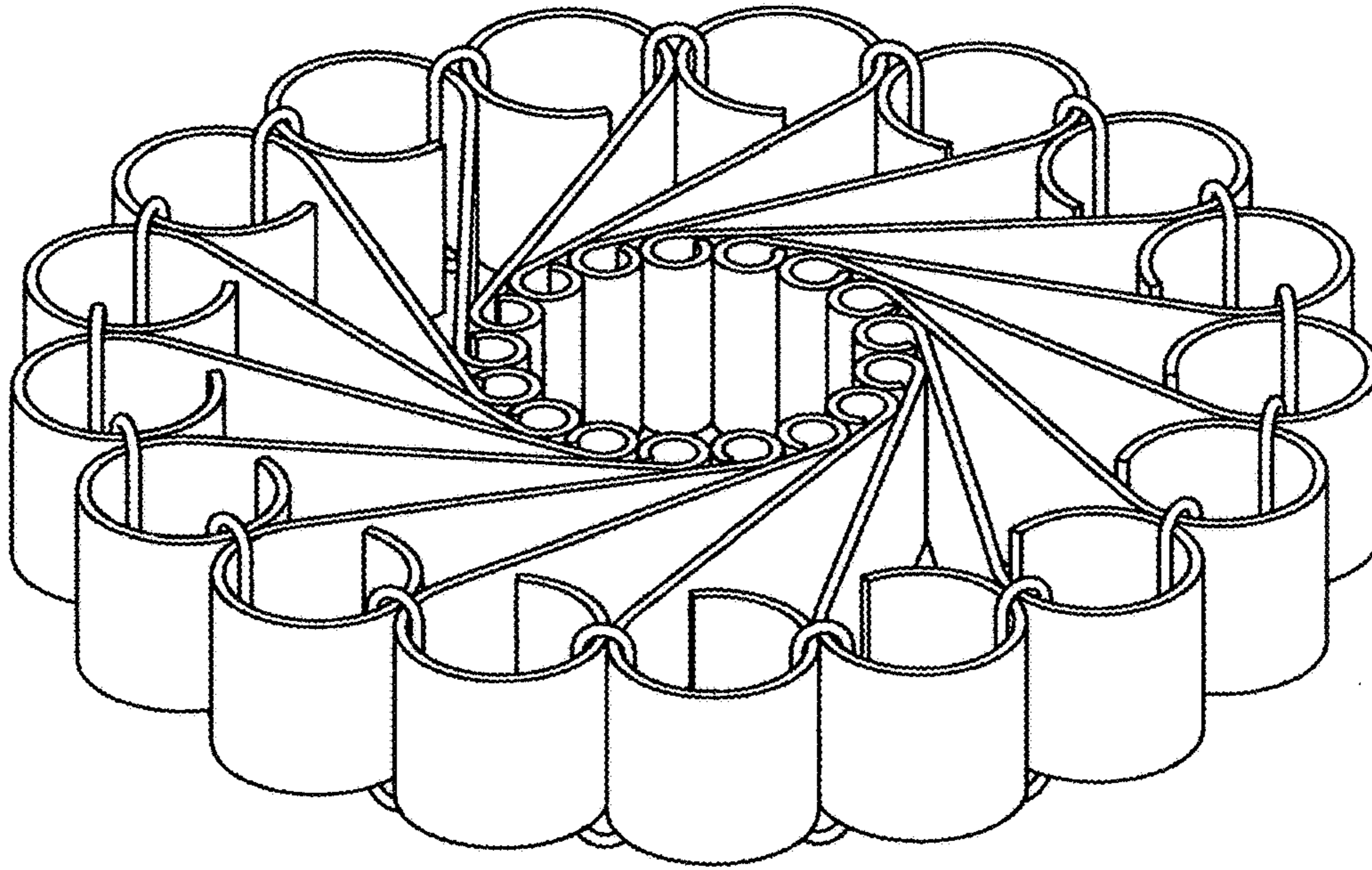

Fig. 5

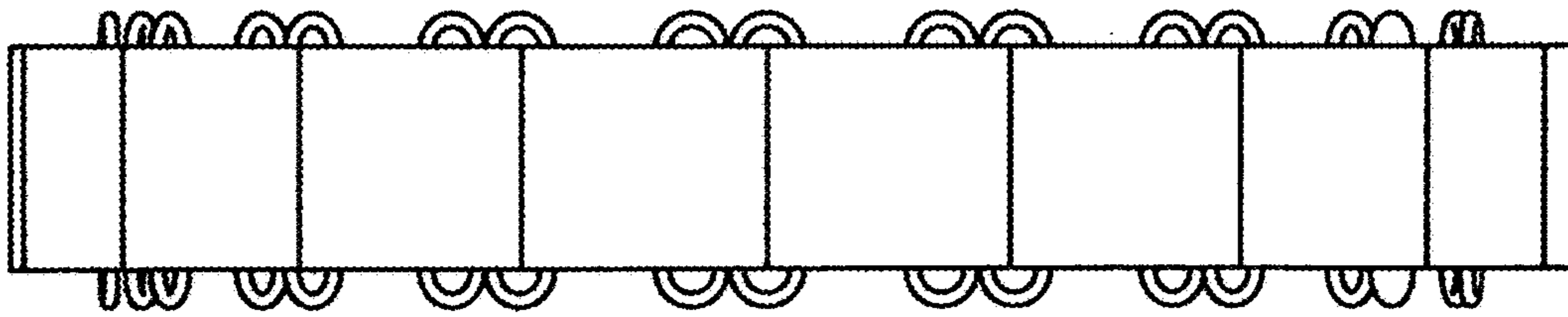

Fig. 6

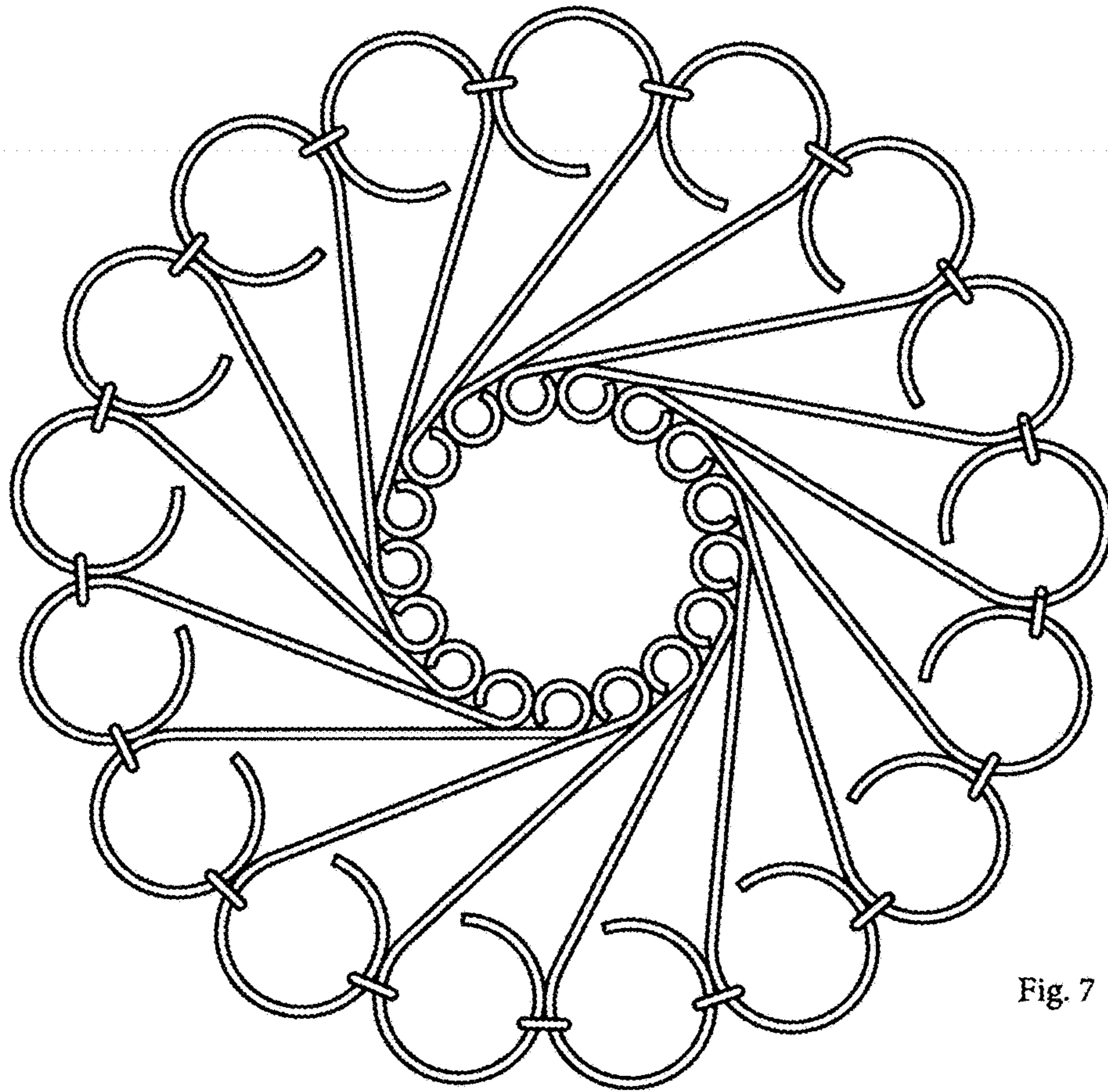

Fig. 7

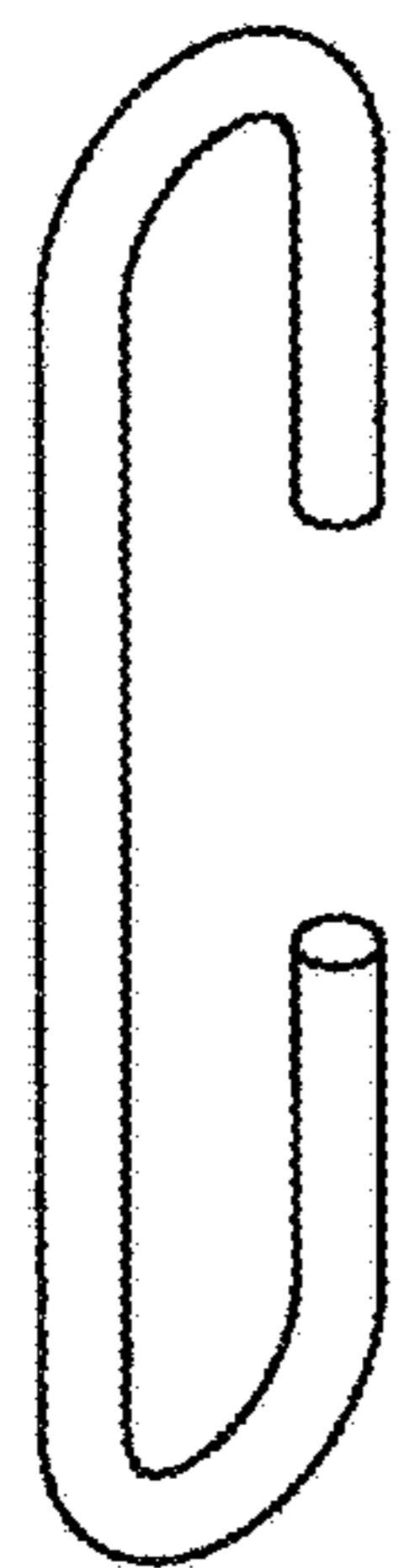

Fig. 8