



US00D851048S

(12) **United States Design Patent**  
**Duggan**

(10) **Patent No.:** **US D851,048 S**  
(45) **Date of Patent:** **\*\* Jun. 11, 2019**

(54) **HOUSING FOR ELECTRICAL OR CABLING WIRES**

(71) Applicant: **Shawn Duggan**, Holly, MI (US)

(72) Inventor: **Shawn Duggan**, Holly, MI (US)

(\*\*) Term: **15 Years**

(21) Appl. No.: **29/592,463**

(22) Filed: **Jan. 30, 2017**

(51) **LOC (11) Cl.** ..... **13-03**

(52) **U.S. Cl.**  
USPC ..... **D13/155**

(58) **Field of Classification Search**

USPC ..... D13/151-155, 184, 103  
CPC ..... H01H 85/165; H01R 4/70; H01R 27/02;  
H02G 15/04; H05K 5/00

See application file for complete search history.

D580,870 S \* 11/2008 Guercio ..... D13/152  
D777,371 S \* 1/2017 Yang ..... D26/142  
D786,031 S \* 5/2017 Whitten ..... D8/14  
2013/0133915 A1 \* 5/2013 Feye-Hohmann .....  
H01R 13/6273  
174/50  
2016/0139355 A1 \* 5/2016 Petersen ..... G02B 6/4478  
385/100  
2018/0040996 A1 \* 2/2018 Zhu ..... H01R 27/02

\* cited by examiner

*Primary Examiner* — Jennifer Rivard

*Assistant Examiner* — Alison M Ofstun

(74) *Attorney, Agent, or Firm* — Mitchell Law PLLC;  
Matthew W. Mitchell

(57) **CLAIM**

The ornamental design for a housing for electrical or cabling wires, as shown and described.

(56) **References Cited**

U.S. PATENT DOCUMENTS

1,579,596 A \* 4/1926 Cote ..... H01H 85/10  
337/290  
D185,959 S \* 8/1959 Schroeder ..... D13/125  
3,984,623 A \* 10/1976 Worden ..... H02G 15/04  
174/138 F  
D279,286 S \* 6/1985 Smith ..... D13/184  
D354,739 S \* 1/1995 Durham ..... D13/184  
5,655,931 A \* 8/1997 Perugini ..... H01R 4/56  
439/573  
6,071,145 A \* 6/2000 Toly ..... H01R 13/53  
439/465  
6,376,774 B1 \* 4/2002 Oh ..... H01H 85/10  
174/92  
7,357,579 B2 \* 4/2008 Feldner ..... G02B 6/3887  
385/56

**DESCRIPTION**

FIG. 1 is a front isometric view of a housing for electrical or cabling wires, showing my new design;  
FIG. 2 is a front view thereof;  
FIG. 3 is a back view thereof;  
FIG. 4 is a right side view thereof;  
FIG. 5 is a left side view thereof; and,  
FIG. 6 is a top plan view thereof.  
The housing for electrical or cabling wires is shown with a symbolic break in its length. The appearance of any portion of the article between the break lines forms no part of the claimed design.

**1 Claim, 6 Drawing Sheets**

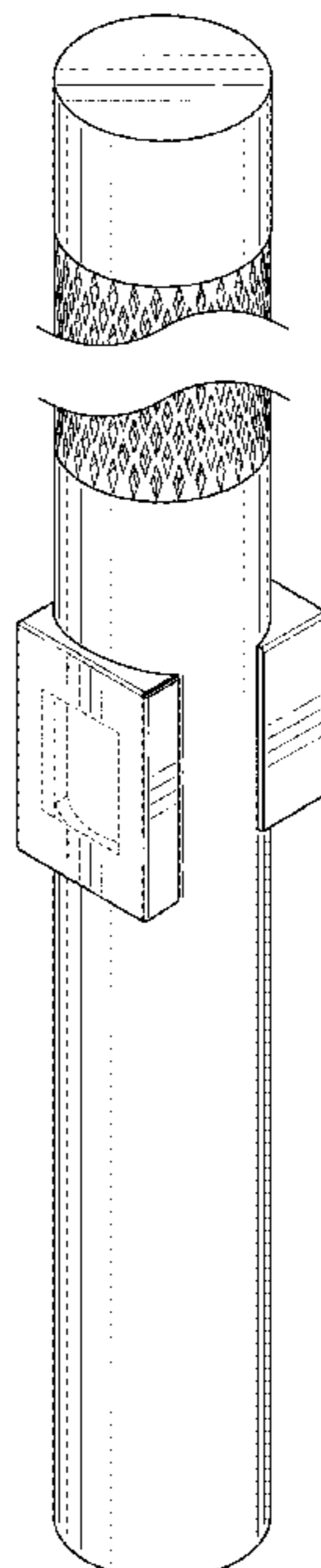

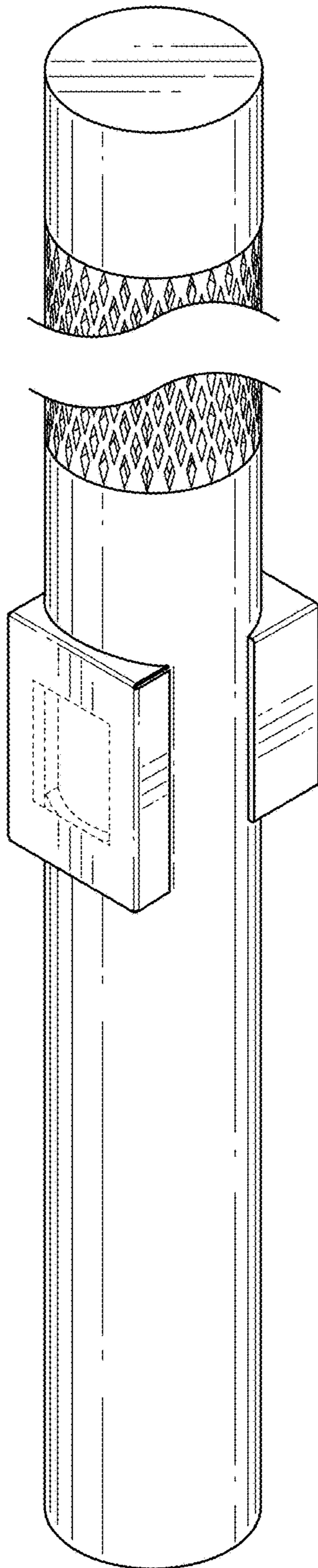

FIG. 1

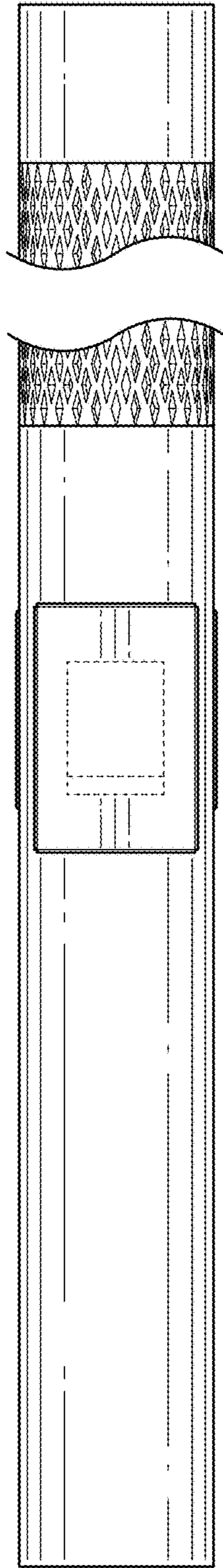

FIG. 2

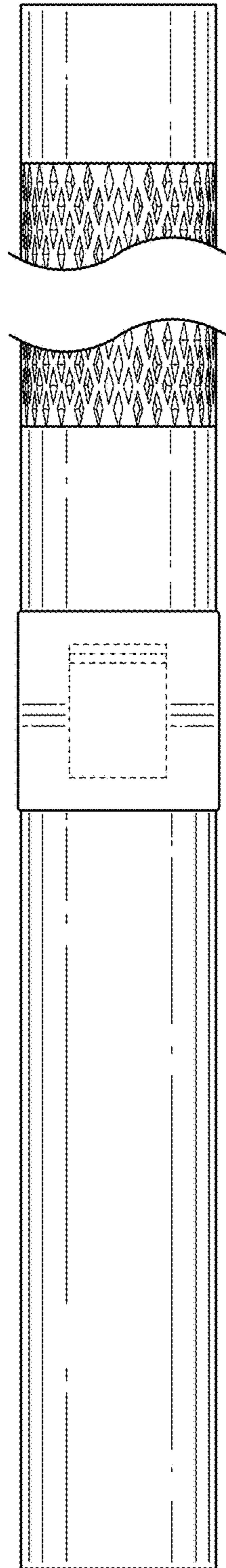

FIG. 3

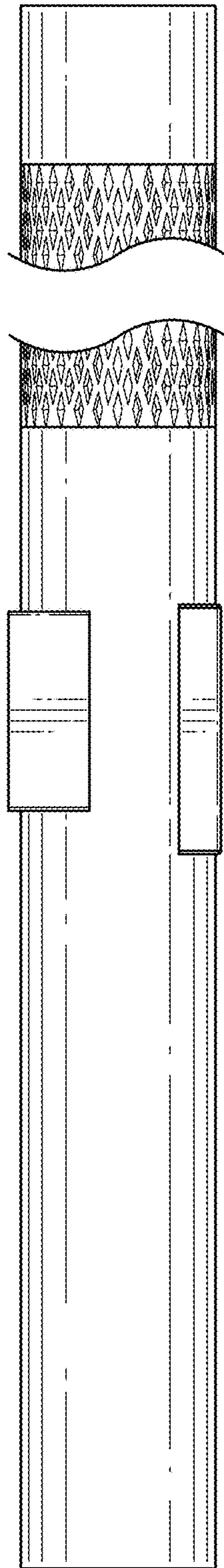

FIG. 4

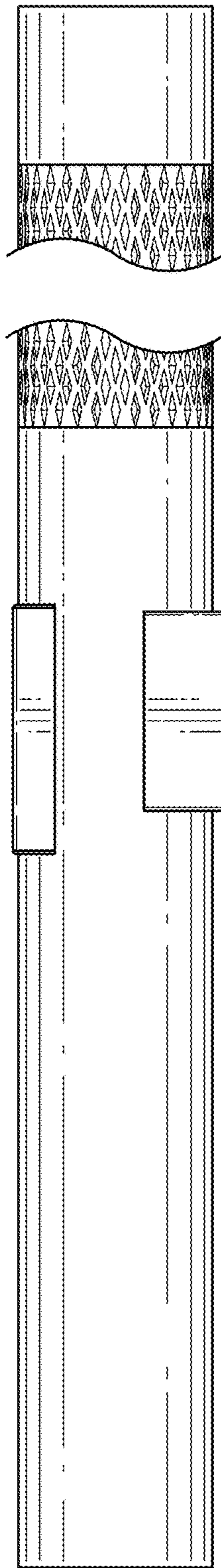

FIG. 5



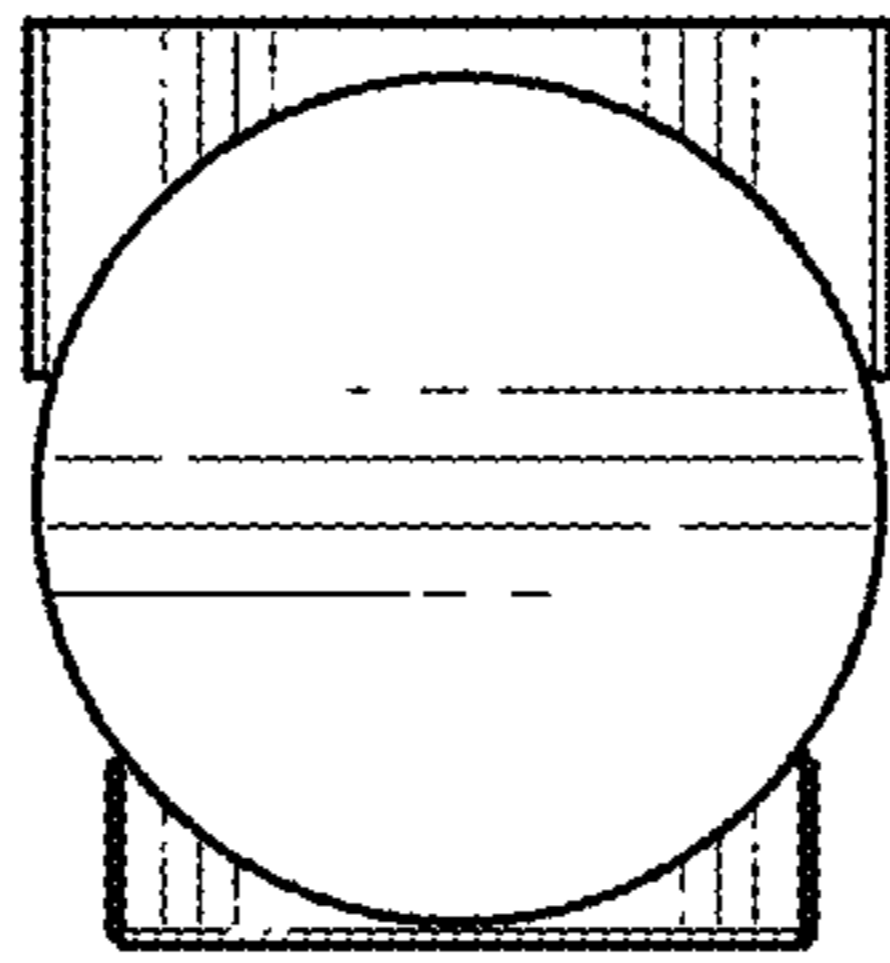

FIG. 6