



US00D851045S

(12) **United States Design Patent**
Nakamura

(10) **Patent No.:** **US D851,045 S**
(45) **Date of Patent:** **** Jun. 11, 2019**

- (54) **ELECTRICAL CONNECTOR**
- (71) Applicant: **Japan Aviation Electronics Industry, Limited**, Tokyo (JP)
- (72) Inventor: **Keisuke Nakamura**, Tokyo (JP)
- (73) Assignee: **JAPAN AVIATION ELECTRONICS INDUSTRY, LIMITED**, Tokyo (JP)
- (**) Term: **15 Years**
- (21) Appl. No.: **29/645,598**
- (22) Filed: **Apr. 27, 2018**
- (30) **Foreign Application Priority Data**

Nov. 1, 2017 (JP) 2017-024397

- (51) **LOC (11) Cl.** **13-03**
- (52) **U.S. Cl.**
USPC **D13/147**
- (58) **Field of Classification Search**
USPC D13/118, 123, 133, 146, 147, 149, 154, D13/173, 184, 199
CPC H01H 85/542; H01H 85/2035; H01H 85/2045; H01R 12/71; H01R 12/75; H01R 12/77; H01R 12/778; H01R 12/81; H01R 13/56; H01R 13/58; H01R 13/582; H01R 13/627; H01R 13/6273; H01R 13/639; H01R 13/68
See application file for complete search history.

(56) **References Cited**

U.S. PATENT DOCUMENTS

- D423,455 S * 4/2000 Konno D13/147
- D423,457 S * 4/2000 Konno D13/147
- D650,753 S * 12/2011 Miyoshi D13/147
- D713,348 S * 9/2014 Katayanagi D13/147
- D741,810 S * 10/2015 Sasaki D13/147
- D742,833 S * 11/2015 Ashibu D13/147
- D744,426 S * 12/2015 Yamashita D13/146
- D767,495 S * 9/2016 Halleck D13/147

- 2005/0106910 A1* 5/2005 Chiu H01R 13/447
439/136
- 2005/0170677 A1* 8/2005 Bricaud H01R 13/639
439/76.1
- 2018/0123285 A1* 5/2018 Nakamura H01R 12/75

FOREIGN PATENT DOCUMENTS

- JP 2018073612 A * 5/2018 H01R 12/75

* cited by examiner

Primary Examiner — Angela J Lee

Assistant Examiner — Shawn T Gingrich

(74) *Attorney, Agent, or Firm* — Manabu Kanesaka

(57) **CLAIM**

The ornamental design for an electrical connector, as shown and described.

DESCRIPTION

FIG. 1 is a front elevational view of an electrical connector showing my new design;
 FIG. 2 is a rear elevational view thereof;
 FIG. 3 is a right side elevational view thereof;
 FIG. 4 is a left side elevational view thereof;
 FIG. 5 is a top plan view thereof;
 FIG. 6 is a bottom plan view thereof;
 FIG. 7 is a perspective view showing a front, top and right side thereof;
 FIG. 8 is a perspective view showing a rear, bottom and left side thereof;
 FIG. 9 is a perspective view showing a front, right side and bottom thereof; and,
 FIG. 10 is a perspective view showing a rear, left side and top thereof.

The dashed broken line showing of the electrical connector is for the purpose of illustrating portions of the article, and the dot-dash broken lines define the bounds of the claimed design. The dashed broken line and the dot-dash broken line form no part of the claimed design.

1 Claim, 6 Drawing Sheets

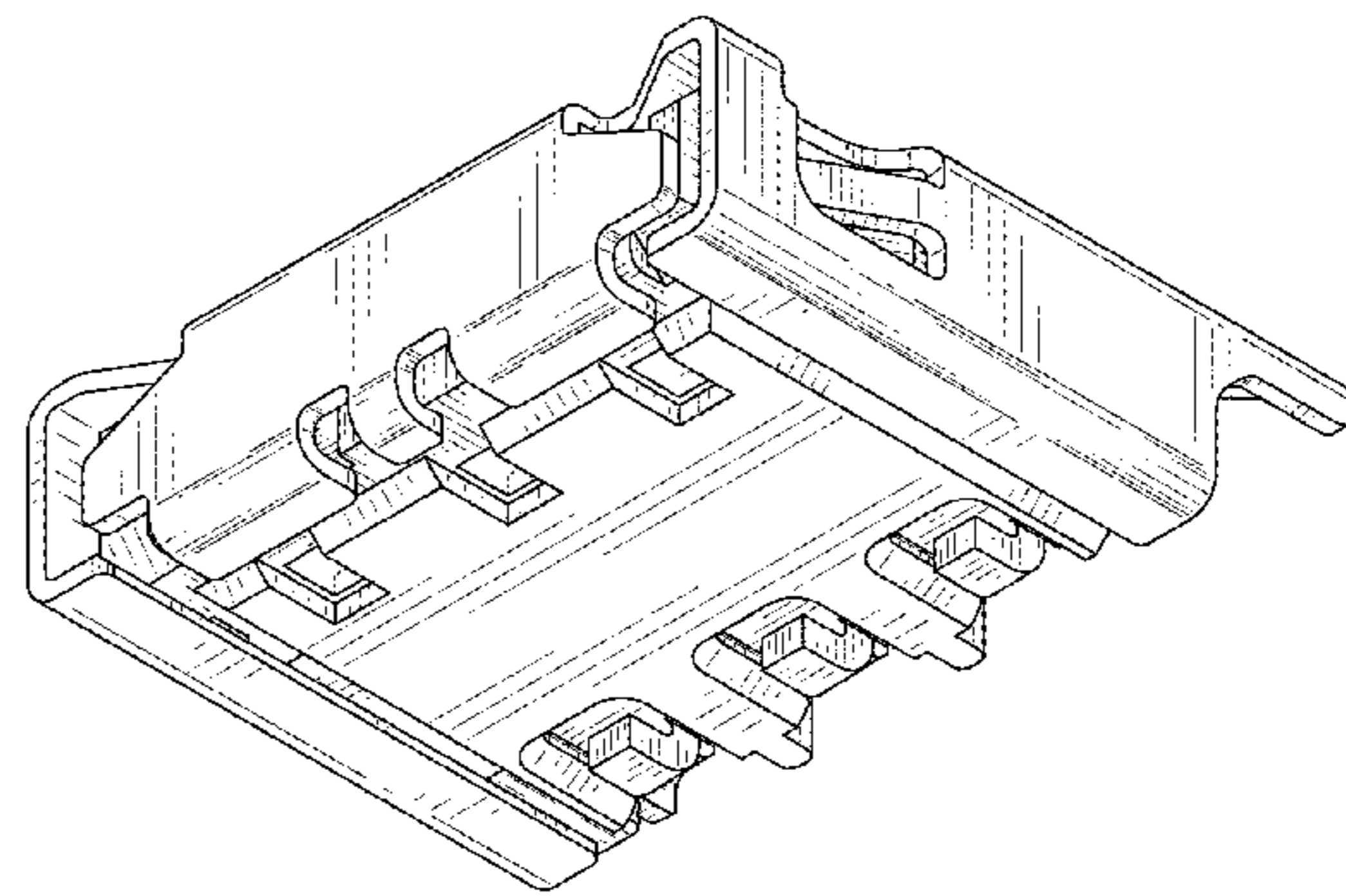
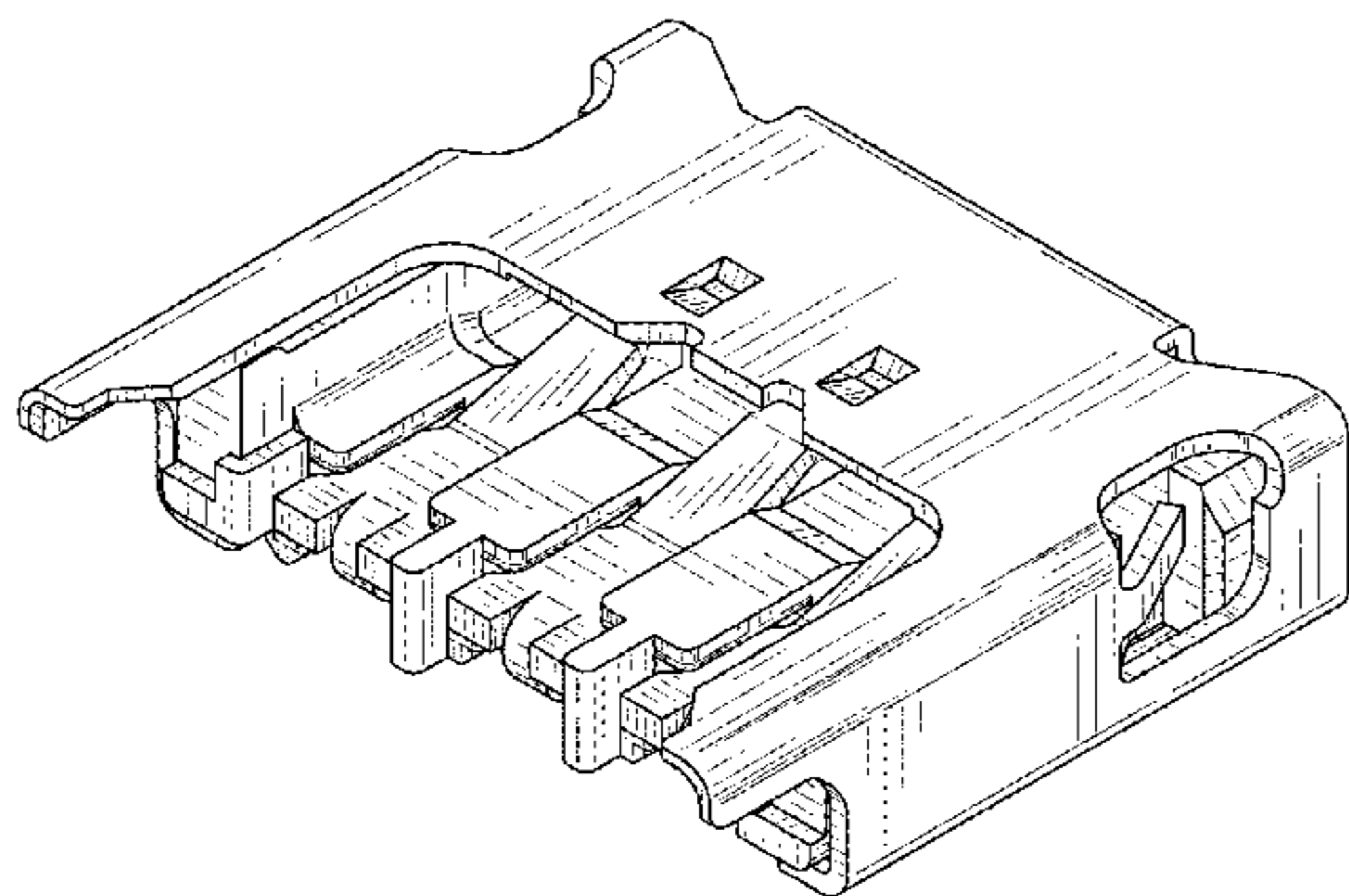

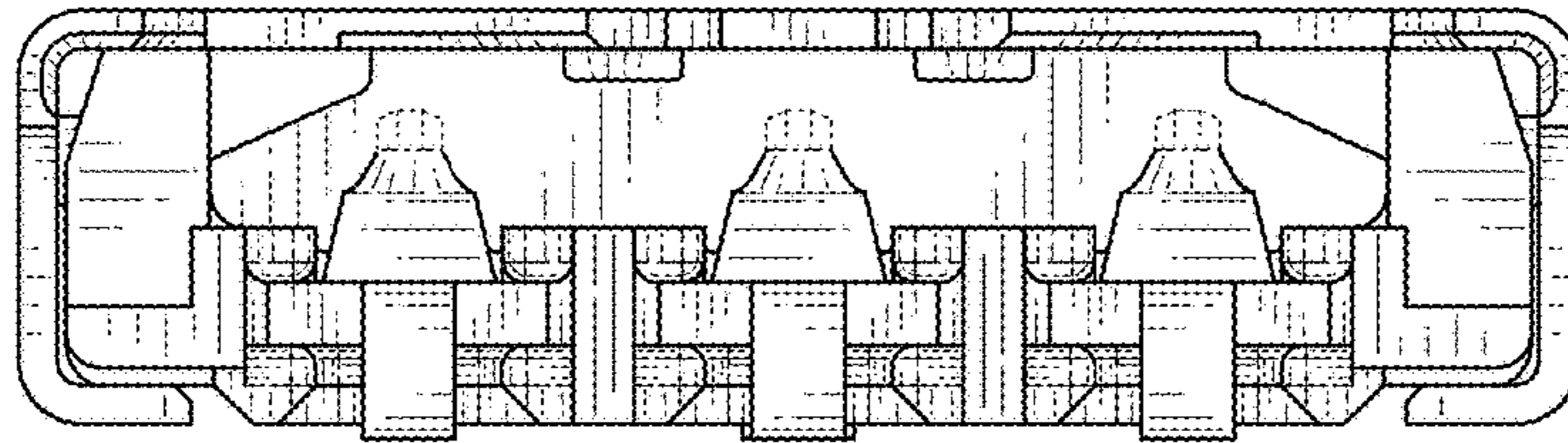

FIG. 1

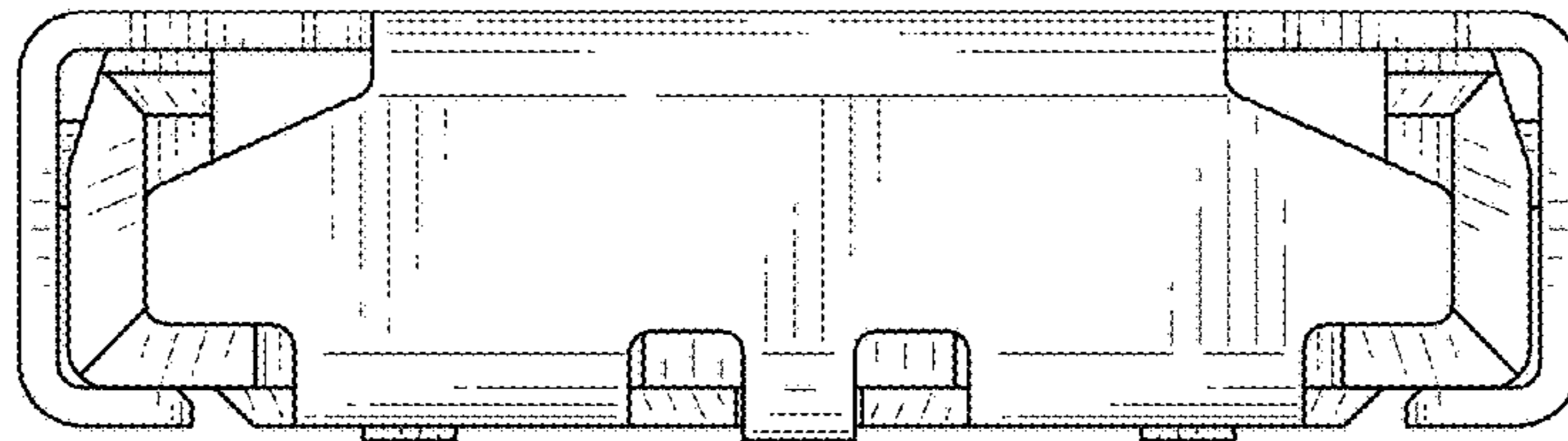

FIG. 2

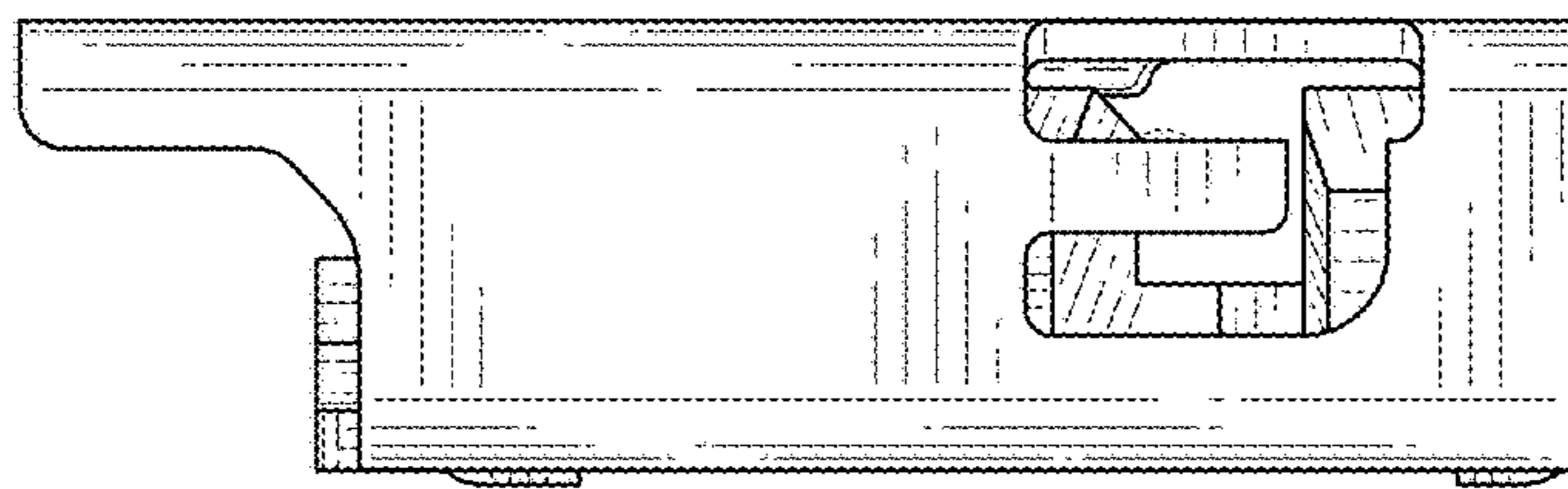

FIG. 3

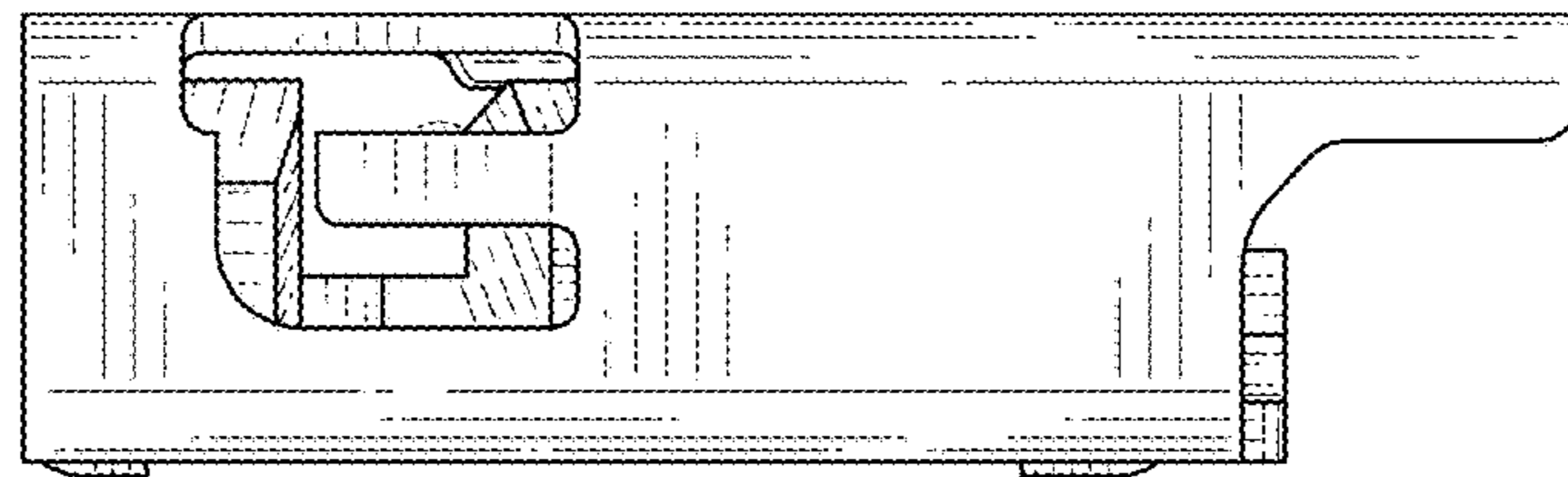

FIG. 4

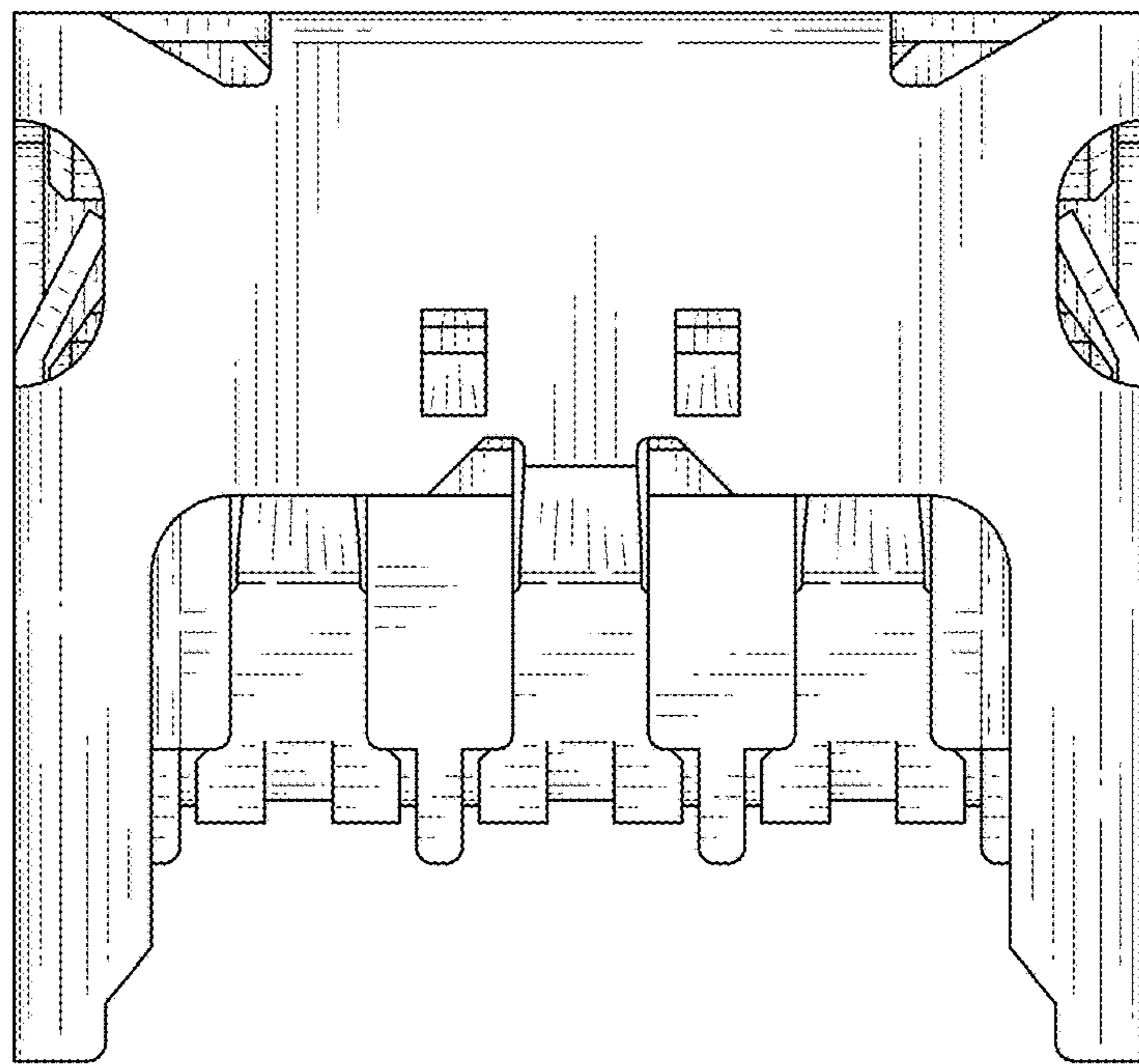

FIG. 5

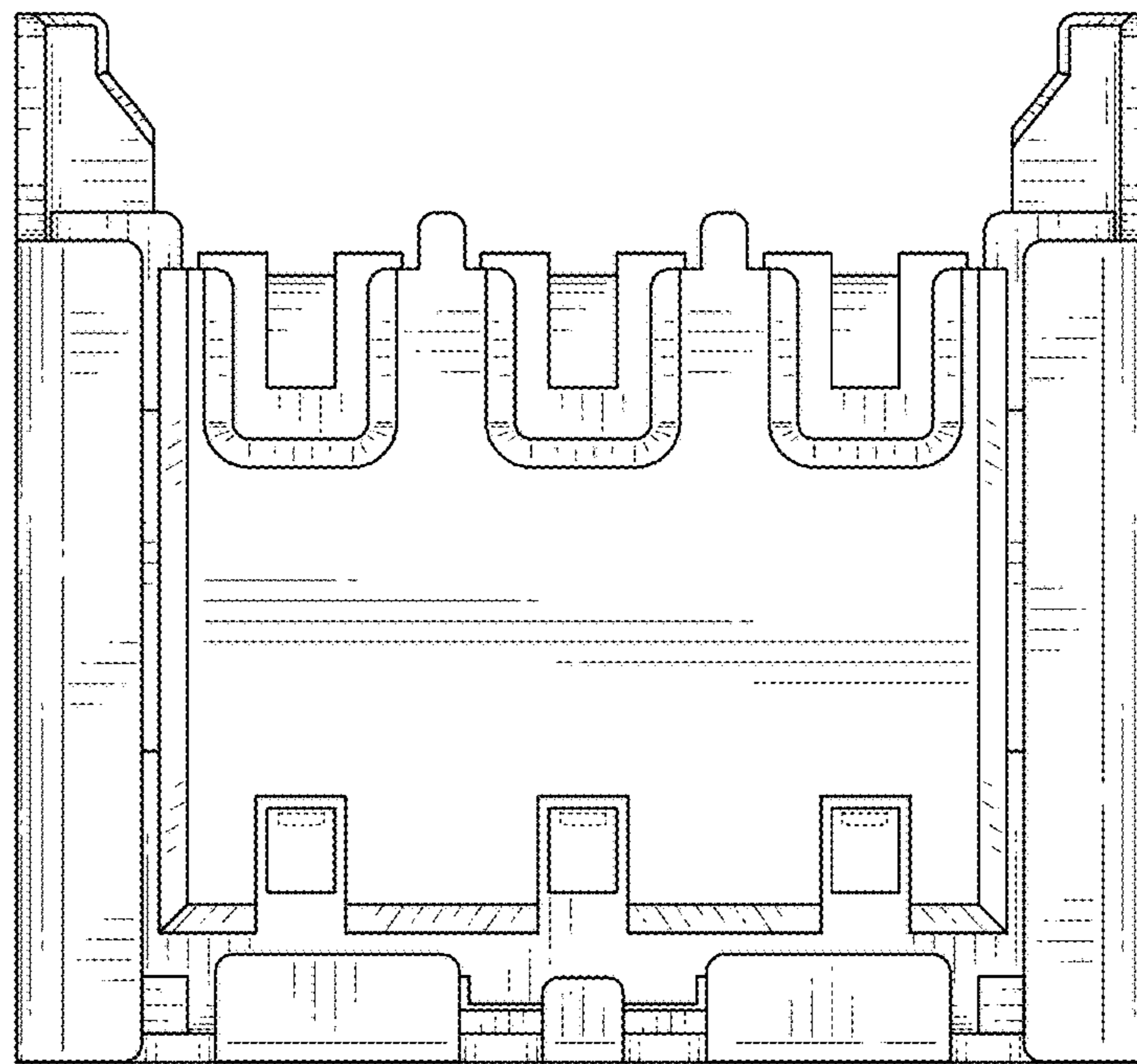

FIG. 6

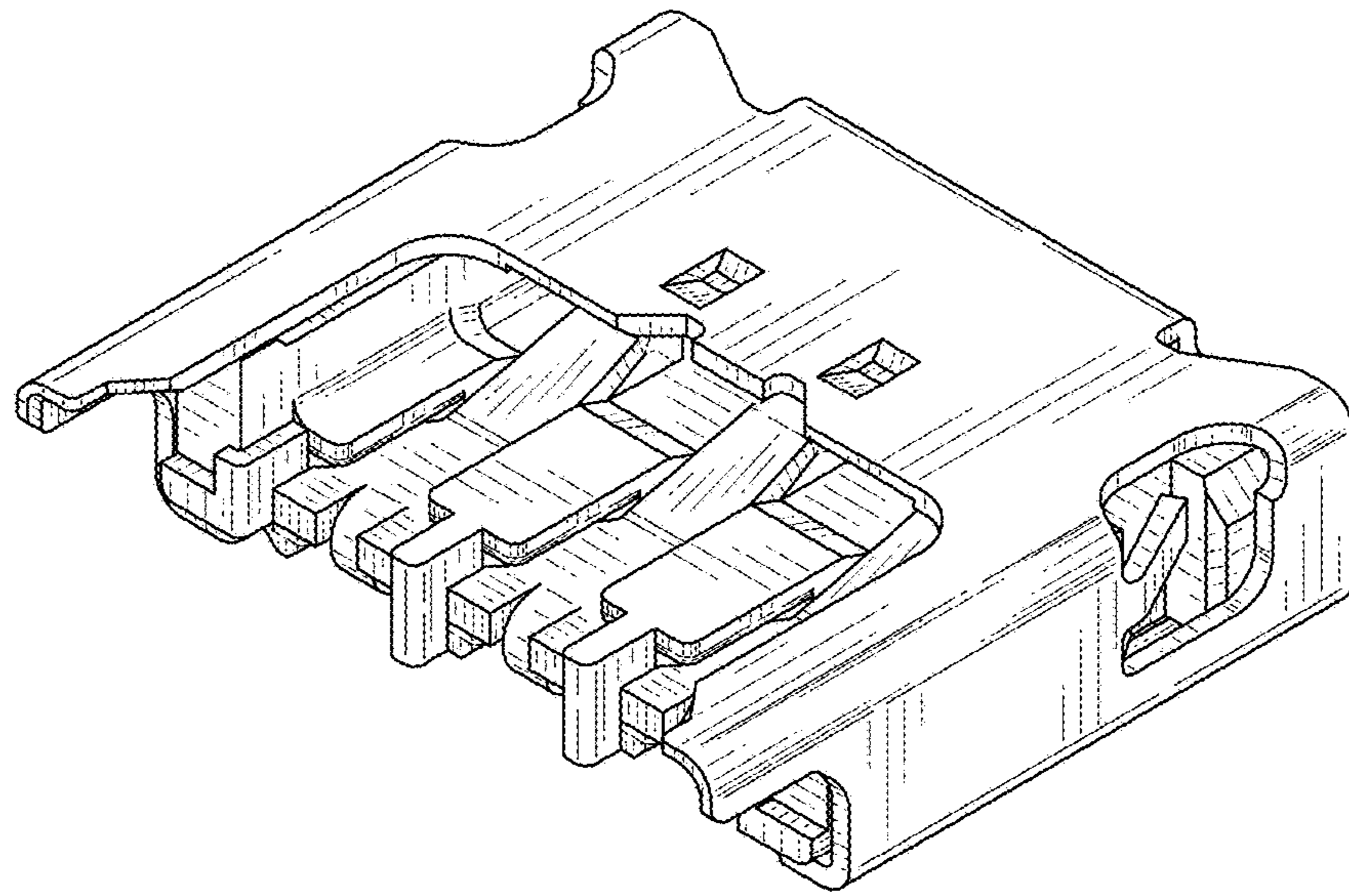

FIG. 7

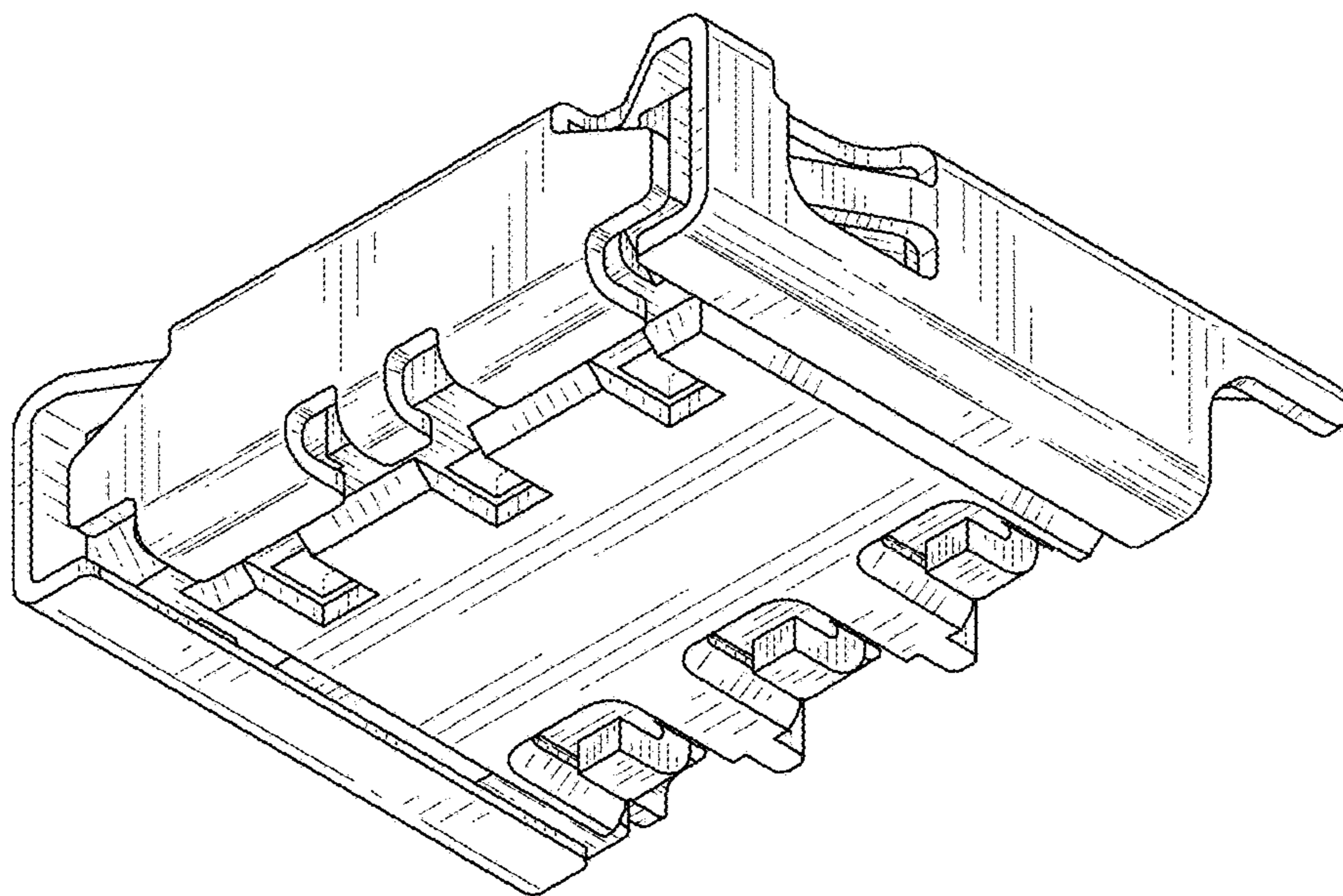

FIG. 8

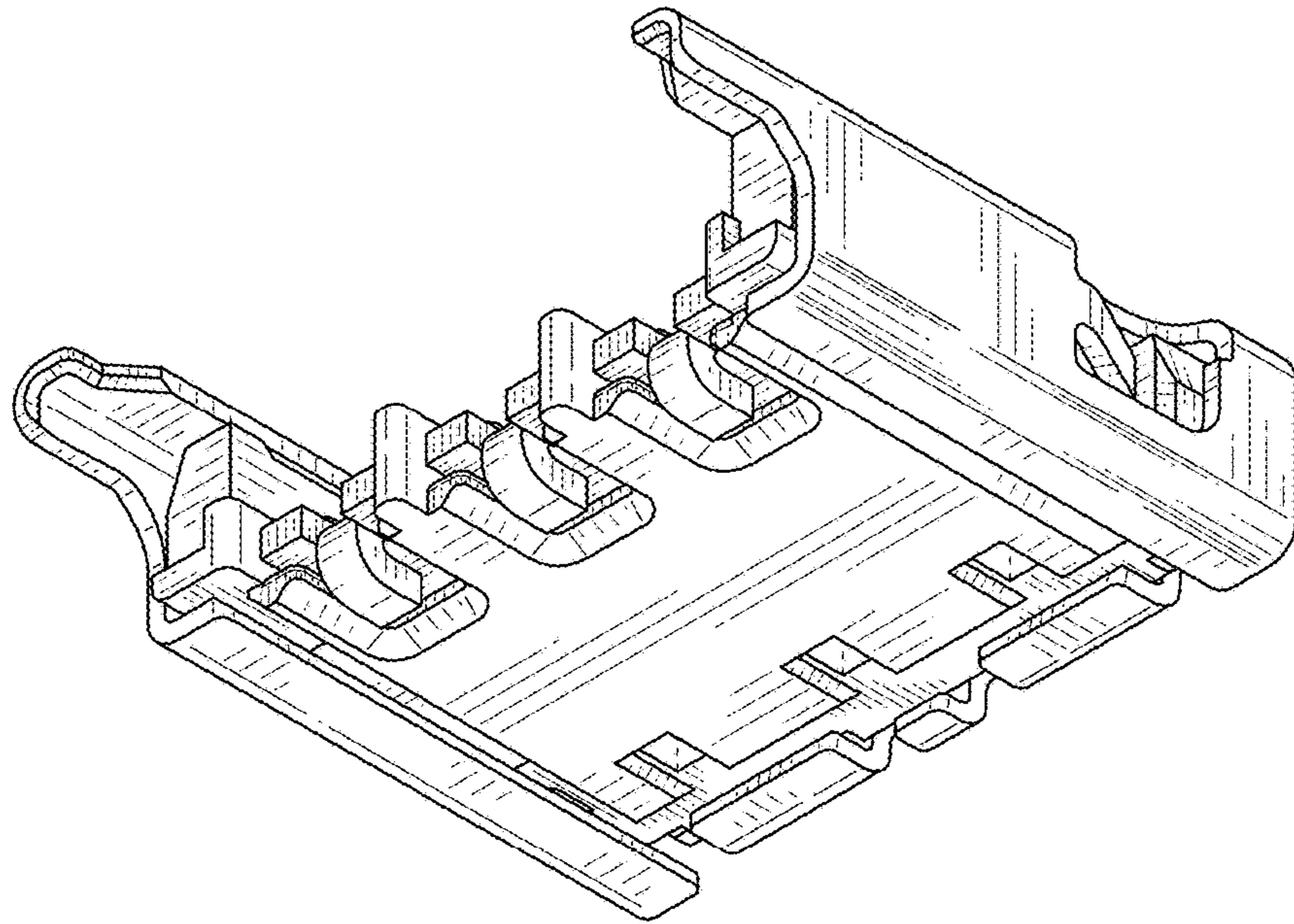

FIG. 9

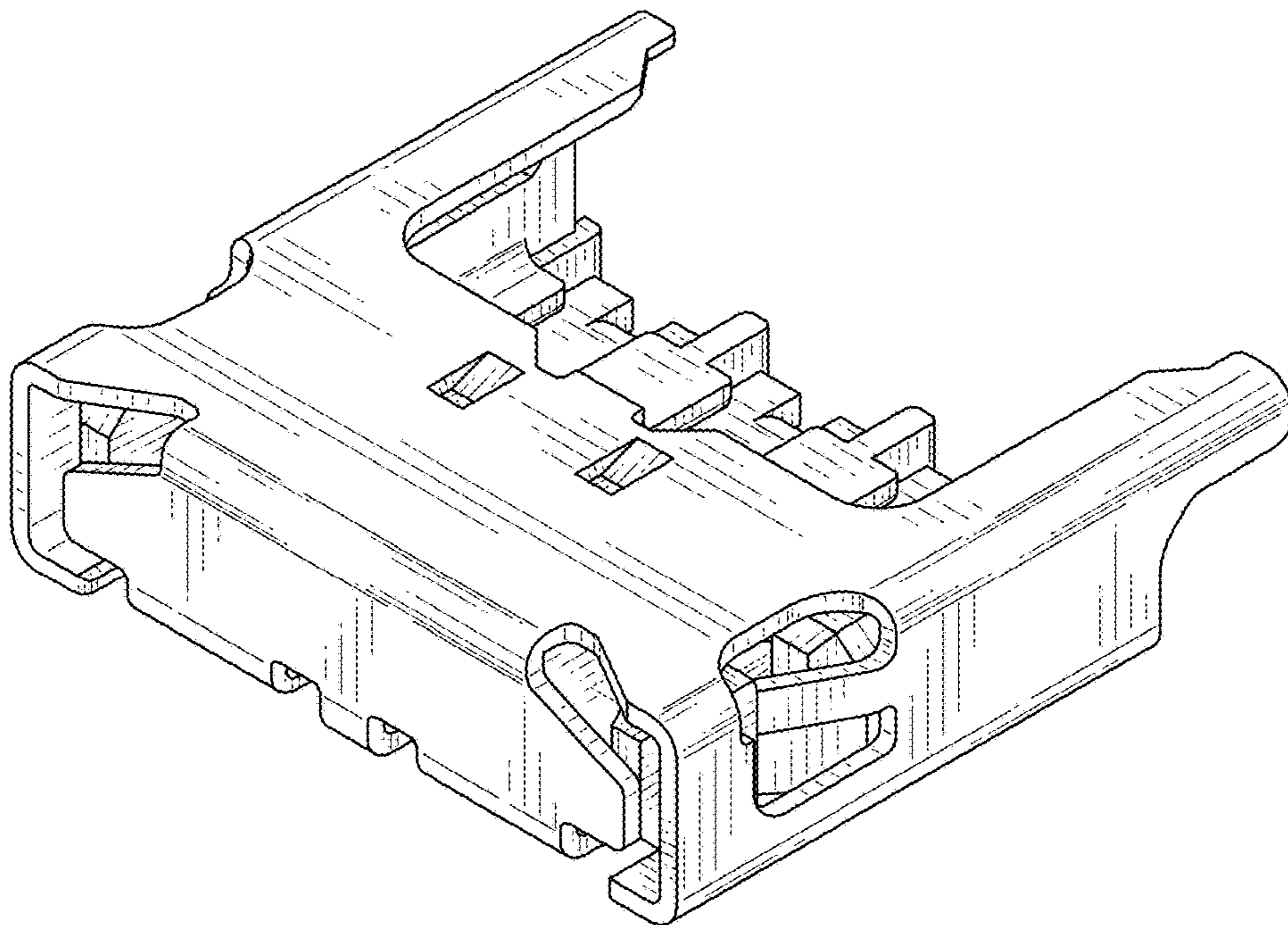

FIG. 10