



US00D850905S

(12) **United States Design Patent** (10) **Patent No.:** **US D850,905 S**
Mitten et al. (45) **Date of Patent:** **** Jun. 11, 2019**

(54) **RE-CLOSEABLE TEAR OPEN PACK**

(71) Applicant: **Altria Client Services LLC**,
Richmond, VA (US)

(72) Inventors: **Robert T. Mitten**, Glen Allen, VA
(US); **Scott A. Fath**, Richmond, VA
(US); **William J. Bogdziewicz**,
Richmond, VA (US); **Benjamin Ivry**,
Richmond, VA (US); **Aaron Ovadia**,
Beit Shemesh (IL); **Gavriel Zeitlin**,
Beit Shemesh (IL)

(73) Assignee: **ALTRIA CLIENT SERVICES LLC**,
Richmond, VA (US)

(**) Term: **15 Years**

(21) Appl. No.: **29/625,136**

(22) Filed: **Nov. 7, 2017**

Related U.S. Application Data

(63) Continuation of application No. 29/569,608, filed on
Jun. 29, 2016, now Pat. No. Des. 801,803.

(51) **LOC (11) Cl.** **09-03**

(52) **U.S. Cl.**
USPC **D9/420**

(58) **Field of Classification Search**
USPC D9/414-418, 420, 423, 425, 430, 432,
D9/607, 619, 702, 709; D21/393;
D3/274; D27/189, 629; 206/256
CPC A24F 15/18; B65D 1/00; B65D 23/00;
B65D 85/1045; B65D 85/10; B65D 43/16
See application file for complete search history.

(56) **References Cited**

U.S. PATENT DOCUMENTS

D35,615 S 1/1902 Stecher
1,009,804 A 11/1911 Sugarman
D94,062 S 12/1934 Wilsdon
3,037,684 A 6/1962 Andrews et al.
D214,879 S 8/1969 Roccaforte et al.

D218,677 S 9/1970 Biallo
D219,266 S 11/1970 Biallo
D221,626 S 8/1971 Fine
3,861,583 A 1/1975 Tingley et al.
D234,252 S 2/1975 Gerson
4,062,486 A 12/1977 Goodrich
D250,748 S 1/1979 Leger
4,614,297 A 9/1986 Davis et al.
4,679,693 A 7/1987 Forman
4,773,542 A 9/1988 Schillinger et al.
D303,722 S 9/1989 Marlow et al.
4,917,288 A 4/1990 Heitele et al.
4,949,841 A 8/1990 Focke et al.
5,014,855 A 5/1991 Roccaforte
5,018,625 A 5/1991 Focke et al.
5,123,589 A 6/1992 Cote
5,184,725 A 2/1993 Reinheimer et al.
5,190,155 A 3/1993 Grunwald
5,325,963 A * 7/1994 Focke B65D 85/1018
206/265
5,358,171 A 10/1994 Focke
5,462,223 A 10/1995 Focke et al.
D365,023 S 12/1995 Abrams et al.
5,511,722 A 4/1996 Dixon
D387,976 S 12/1997 Mori
5,975,415 A 11/1999 Zehnal
D434,319 S 11/2000 Mori
D434,652 S 12/2000 Mori
D441,497 S 5/2001 Focke et al.
6,279,819 B1 8/2001 Schultz
D448,888 S 10/2001 Focke et al.
6,334,532 B1 1/2002 Tambo et al.
D465,416 S 11/2002 Dzwil et al.
6,604,676 B2 8/2003 Giblin
D484,046 S 12/2003 Kopecky
D487,532 S 3/2004 Draghetti et al.
D503,087 S 3/2005 Dzwil et al.
D531,498 S 11/2006 Fluegel et al.
7,178,712 B2 2/2007 Schultz et al.
D545,188 S 6/2007 Billig et al.
D553,494 S 10/2007 Dehlin
7,353,940 B2 4/2008 Sendo
D579,325 S 10/2008 Bray et al.
D594,323 S 6/2009 Friedman et al.
D594,596 S 6/2009 Mitten et al.
D601,747 S 10/2009 Tabrah
D601,748 S 10/2009 Pipes et al.
D607,318 S 1/2010 Collins
D610,303 S 2/2010 Valle et al.
D616,146 S 5/2010 Holford
7,717,260 B2 * 5/2010 Buse B65D 85/1045
206/242
7,717,319 B2 5/2010 Adam

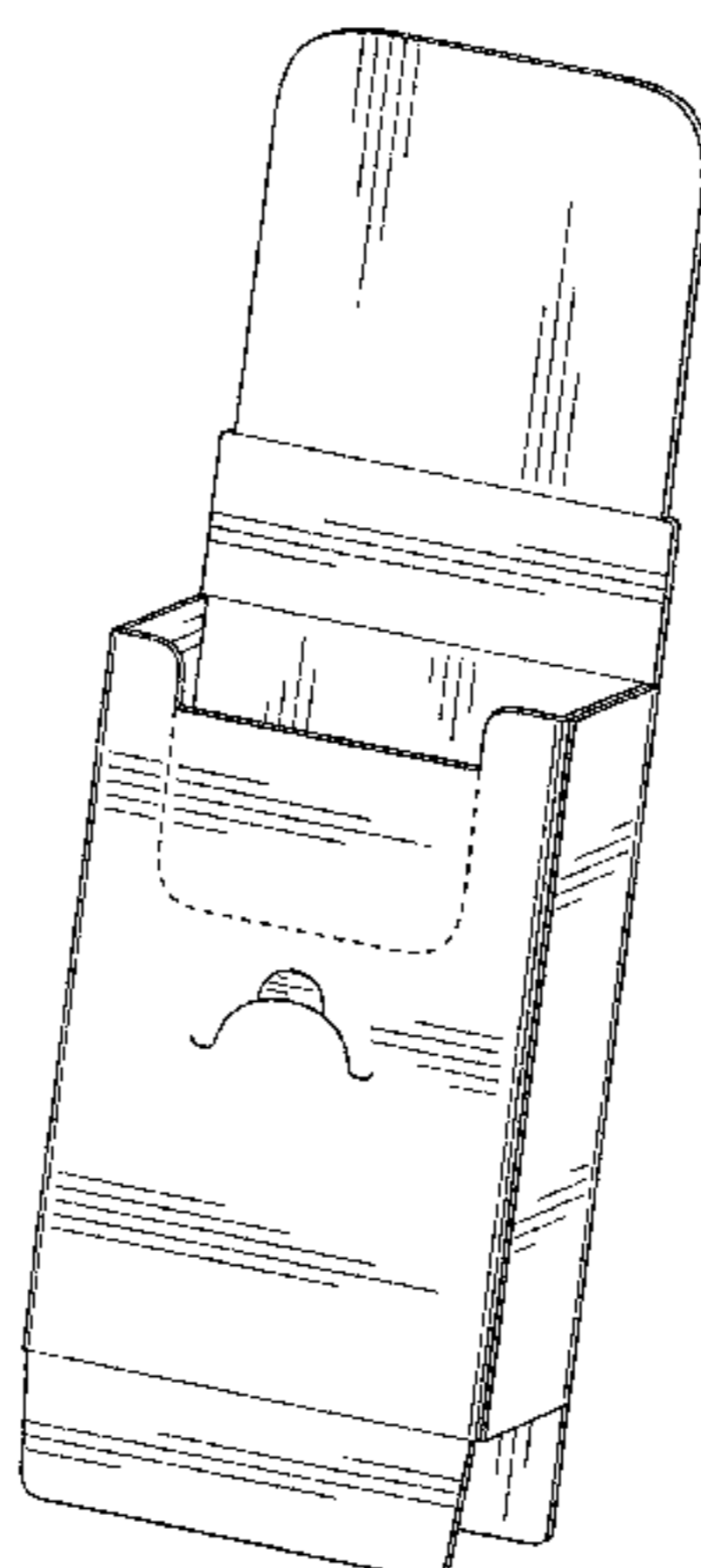

7,731,024	B2	6/2010	Bouno et al.	
D619,454	S	7/2010	Fluegel et al.	
D624,401	S	9/2010	Friedman et al.	
D644,100	S	8/2011	Stacy-Ryan	
8,016,105	B2	9/2011	Sendo	
8,061,586	B2	11/2011	Fluegel et al.	
D654,358	S	2/2012	Ampadu et al.	
8,123,030	B2	2/2012	Hein	
D655,153	S	3/2012	Mitten et al.	
D675,917	S	2/2013	Holford	
8,393,469	B2	3/2013	Aldridge et al.	
8,875,878	B2	11/2014	Young	
9,004,273	B2	4/2015	Tanbo	
D746,673	S	1/2016	Sanfilippo et al.	
D789,782	S *	6/2017	Kahawaiolaa	D9/414
D801,803	S *	11/2017	Mitten	D9/416
D816,507	S *	5/2018	Xie	D9/658
D821,866	S *	7/2018	Scotti	D9/420
D829,092	S *	9/2018	Bandiera	D9/416
D834,409	S *	11/2018	Banacki	D9/420
2007/0228130	A1	10/2007	Arai	
2008/0152264	A1	6/2008	Pokusa et al.	
2010/0170941	A1	7/2010	Mitra-Shah et al.	
2011/0233106	A1	9/2011	Fluegel et al.	
2012/0111746	A1	5/2012	Tanbo et al.	
2012/0199640	A1	8/2012	Thorne et al.	
2012/0291401	A1	11/2012	Mitten et al.	
2013/0319886	A1	12/2013	Ledermann	
2014/0311930	A1 *	10/2014	Buse	B65B 19/20 206/268
2016/0229620	A1	8/2016	Steinkamp et al.	
2016/0368645	A1	12/2016	Buse	
2017/0088341	A1 *	3/2017	Fallon	B65D 75/5838
2017/0197778	A1 *	7/2017	Slooff	B65D 85/1027
2017/0283150	A1 *	10/2017	Petrucci	B65D 77/2096
2018/0362247	A1 *	12/2018	Slooff	B65D 85/1045
2018/0370716	A1 *	12/2018	Draghetti	B65D 85/1009
2019/0002187	A1 *	1/2019	Kahawaiolaa	B65D 85/1045
2019/0002188	A1 *	1/2019	Rudolf	B65D 85/1045
2019/0002190	A1 *	1/2019	Cailleaux	B65D 85/1045

FOREIGN PATENT DOCUMENTS

EP	0615913	A1	9/1994
EP	1588633	A1	10/2005
EP	1739021	A1	1/2007
WO	WO-2012/048671	A2	4/2012

OTHER PUBLICATIONS

U.S. Office Action dated Jul. 6, 2018 in related U.S. Appl. 15/196,406.
International Search Report dated Sep. 4, 2017 issued in PCT/
EP2017/066218.

* cited by examiner

Primary Examiner — Wan Laymon

Assistant Examiner — Clint A Samuel

(74) *Attorney, Agent, or Firm* — Harness, Dickey &
Pierce, P.L.C.

(57) **CLAIM**

The ornamental design for a re-closeable tear open pack, as shown and described.

DESCRIPTION

FIG. 1 is a rear, perspective view of a “sleeve” configuration of a re-closeable tear open pack showing my new design, where dashed broken lines depict a juncture between an upper portion of the back panel and the remainder of the back panel;

FIG. 2 is a rear, perspective view of the “sleeve” configuration of the re-closeable tear open pack shown in FIG. 1, where the sleeve is configured to contain consumable items within the sleeve shown in dashed broken lines;
FIG. 3 is a rear view of the “sleeve” configuration of the re-closeable tear open pack shown in FIG. 1;
FIG. 4 is a front view of the “sleeve” configuration of the re-closeable tear open pack shown in FIG. 1;
FIG. 5 is a left-side view of the “sleeve” configuration of the re-closeable tear open pack shown in FIG. 1;
FIG. 6 is a right-side view of the “sleeve” configuration of the re-closeable tear open pack shown in FIG. 1;
FIG. 7 is a top view of the “sleeve” configuration of the re-closeable tear open pack shown in FIG. 1;
FIG. 8 is a bottom view of the “sleeve” configuration of the re-closeable tear open pack shown in FIG. 1;
FIG. 9 is rear, perspective view of a “sealed-closed” configuration of the re-closeable tear open pack shown in FIG. 1;
FIG. 10 is a rear view of the “sealed-closed” configuration of the re-closeable tear open pack shown in FIG. 9;
FIG. 11 is a front view of the “sealed-closed” configuration of the re-closeable tear open pack shown in FIG. 9;
FIG. 12 is a left-side view of the “sealed-closed” configuration of the re-closeable tear open pack shown in FIG. 9;
FIG. 13 is a right-side view of the “sealed-closed” configuration of the re-closeable tear open pack shown in FIG. 9;
FIG. 14 is a top view of the “sealed-closed” configuration of the re-closeable tear open pack shown in FIG. 9;
FIG. 15 is a bottom view of the “sealed-closed” configuration of the re-closeable tear open pack shown in FIG. 9;
FIG. 16 is a rear, perspective view of an “opened” configuration of the re-closeable tear open pack shown in FIG. 1, where the upper portion of the back panel is configured to remain attached to an inner surface of the tuck panel and is shown in dashed broken lines;
FIG. 17 is a rear, perspective view of the “opened” configuration of the re-closeable tear open pack shown in FIG. 16, where the opened pack is configured to contain consumable items shown in dashed broken lines;
FIG. 18 is a rear view of the “opened” configuration of the re-closeable tear open pack shown in FIG. 16;
FIG. 19 is a front view of the “opened” configuration of the re-closeable tear open pack shown in FIG. 16;
FIG. 20 is a left-side view of the “opened” configuration of the re-closeable tear open pack shown in FIG. 16;
FIG. 21 is a right-side view of the “opened” configuration of the re-closeable tear open pack shown in FIG. 16;
FIG. 22 is a top view of the “opened” configuration of the re-closeable tear open pack shown in FIG. 16;
FIG. 23 is a bottom view of the “opened” configuration of the re-closeable tear open pack shown in FIG. 16;
FIG. 24 is a rear, perspective view of a “re-closed” configuration of the re-closeable tear open pack shown in FIG. 1, where the tuck panel is held in a slot of the back panel;
FIG. 25 is a rear view of the “re-closed” configuration of the re-closeable tear open pack shown in FIG. 24;
FIG. 26 is a front view of the “re-closed” configuration of the re-closeable tear open pack shown in FIG. 24;
FIG. 27 is a left-side view of the “re-closed” configuration of the re-closeable tear open pack shown in FIG. 24;
FIG. 28 is a right-side view of the “re-closed” configuration of the re-closeable tear open pack shown in FIG. 24;
FIG. 29 is a top view of the “re-closed” configuration of the re-closeable tear open pack shown in FIG. 24; and,

FIG. **30** is a bottom view of the “re-closed” configuration of the re-closeable tear open pack shown in FIG. **24**. The dashed broken lines in the drawings represent environmental subject matter that forms no part of the claimed design.

1 Claim, 30 Drawing Sheets

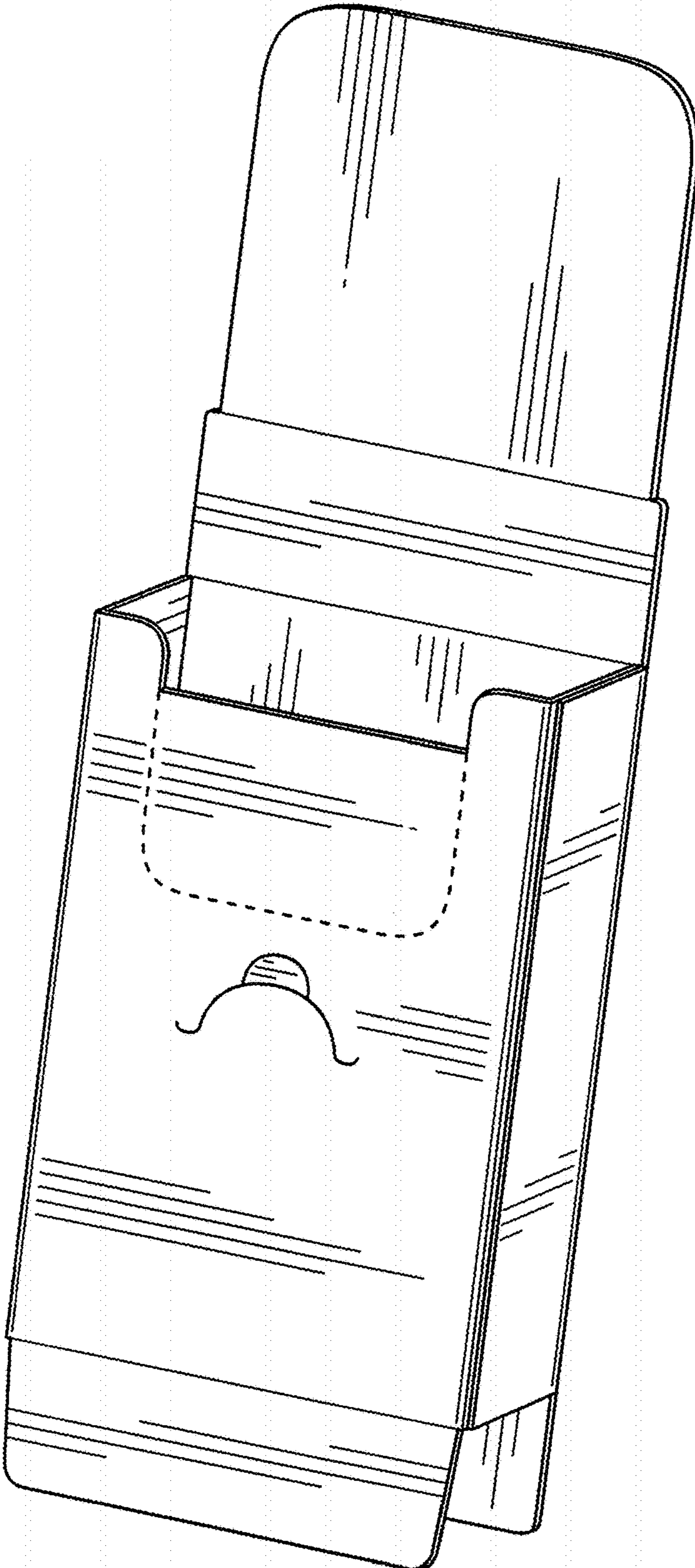

FIG. 1

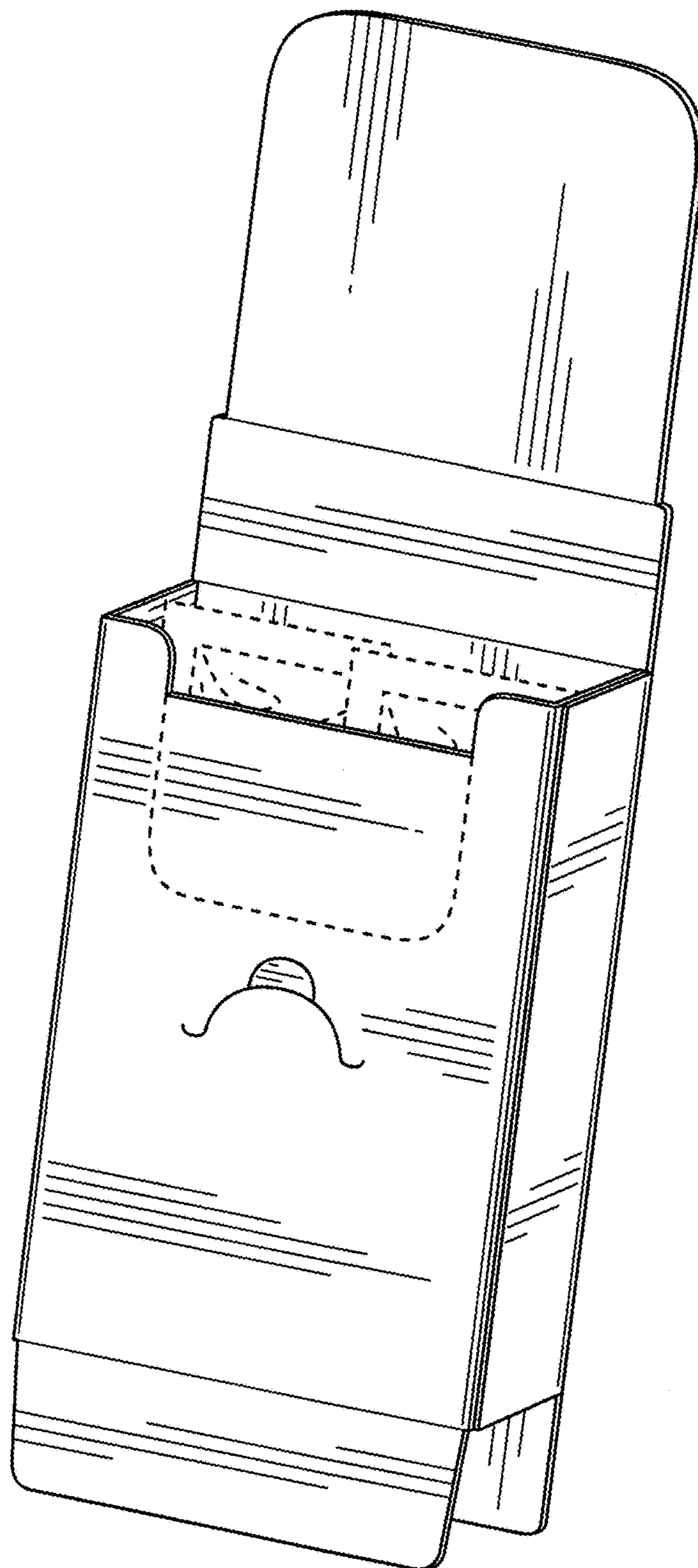

FIG. 2

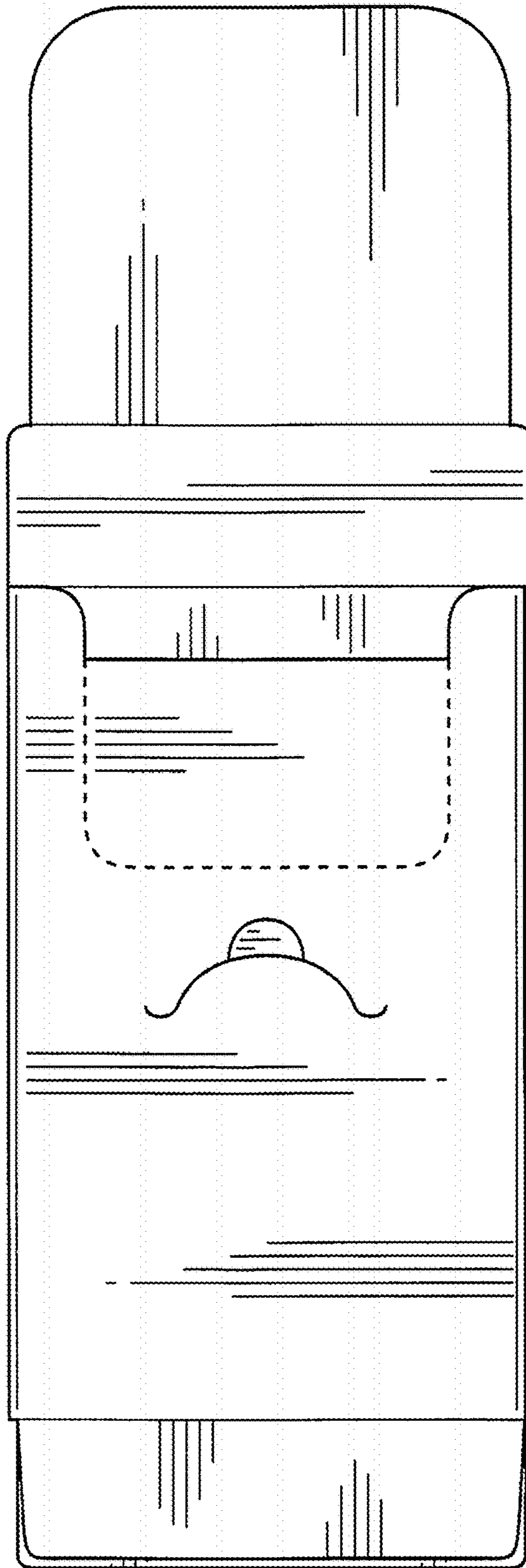

FIG. 3

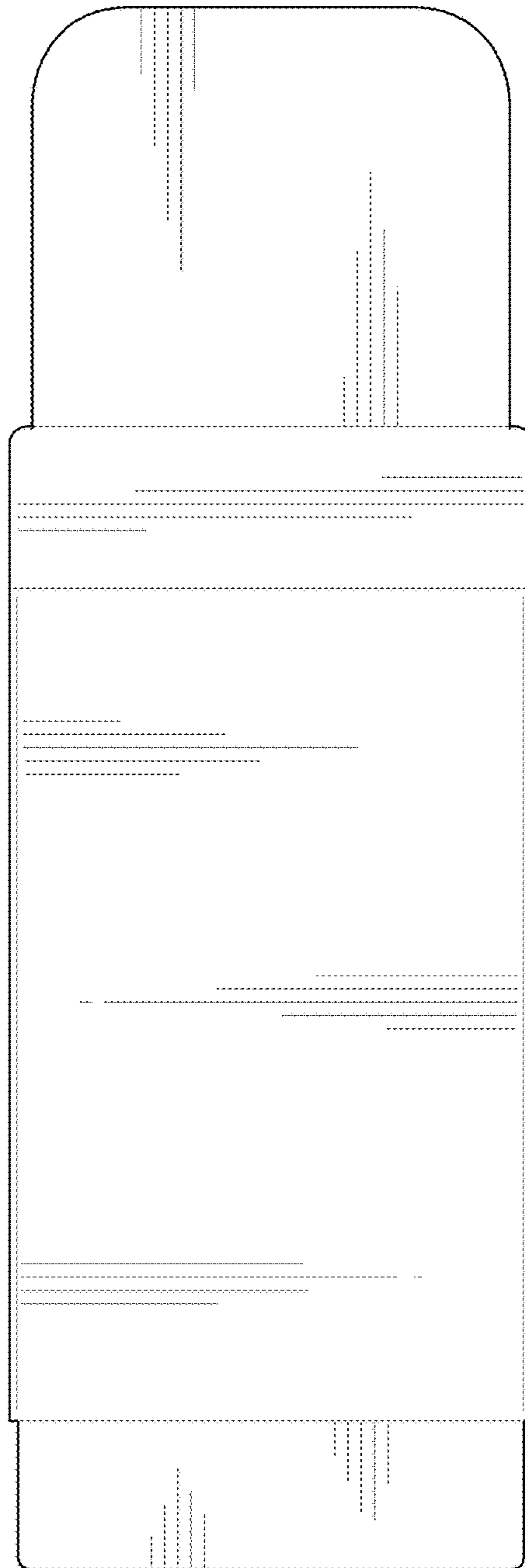

FIG. 4

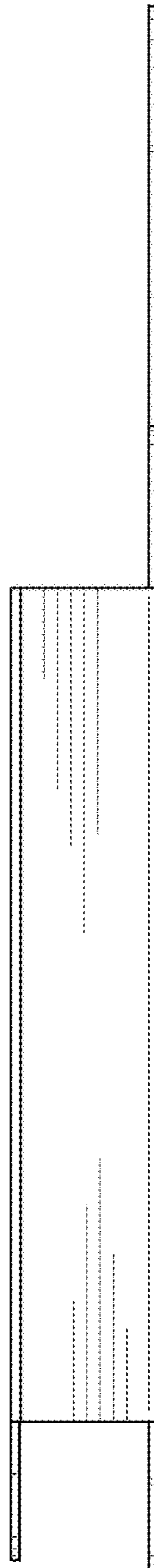

FIG. 5

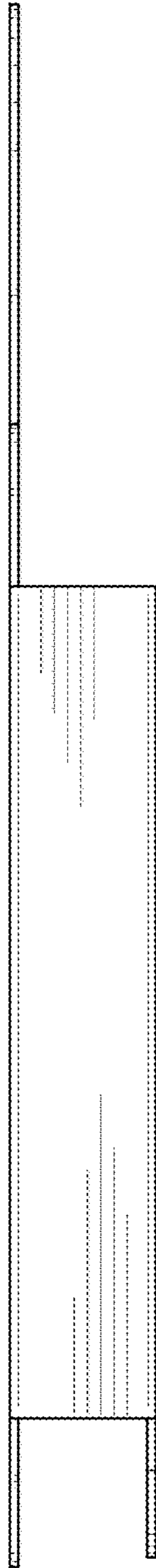

FIG. 6



FIG. 7



FIG. 8

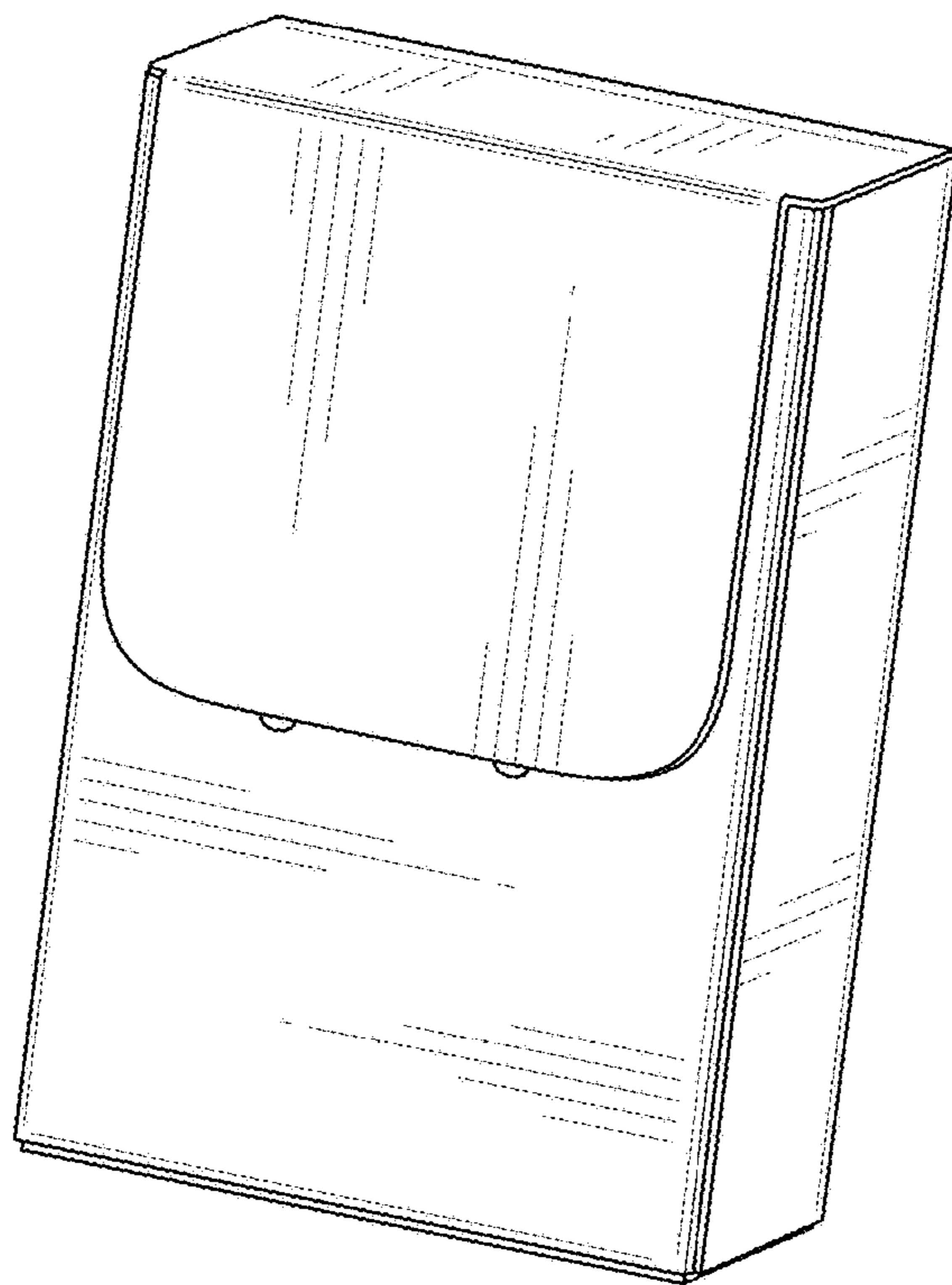

FIG. 9

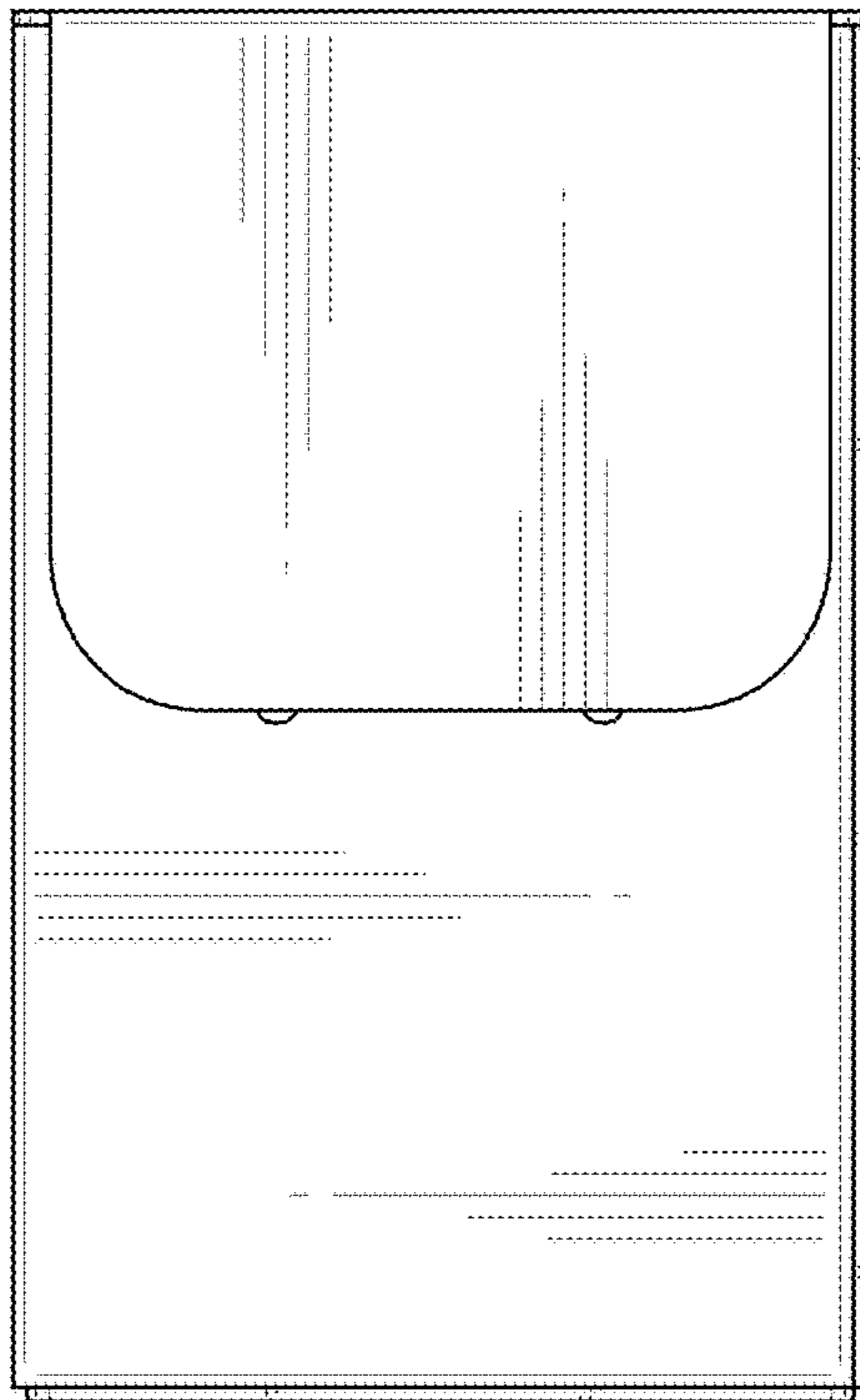

FIG. 10

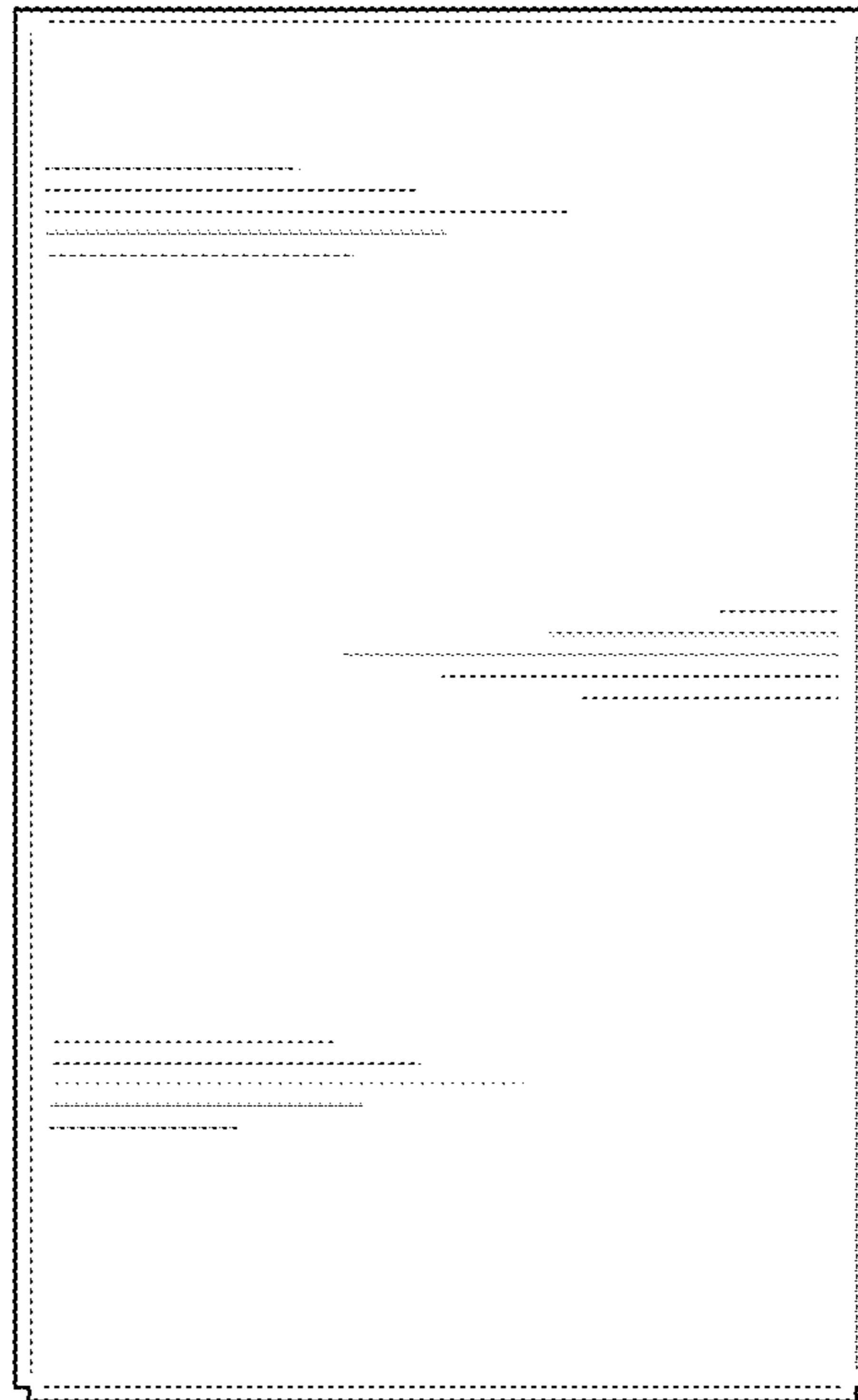

FIG. 11

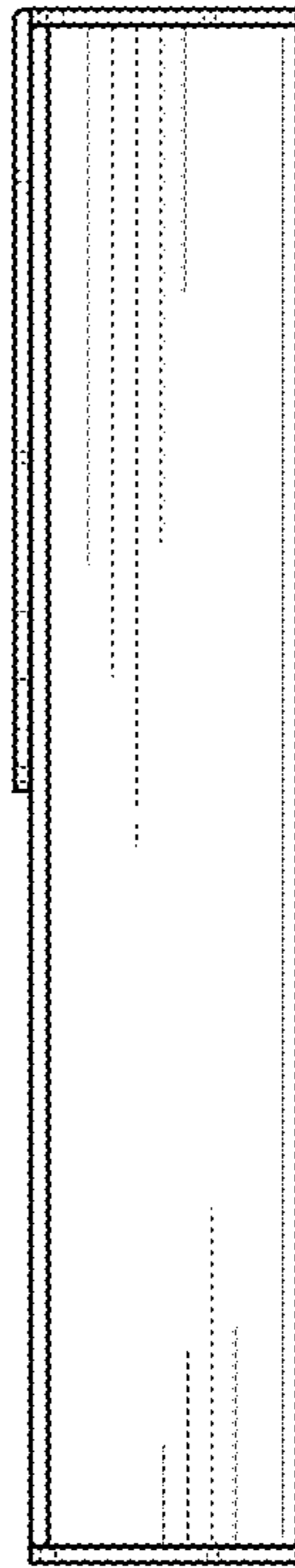

FIG. 12

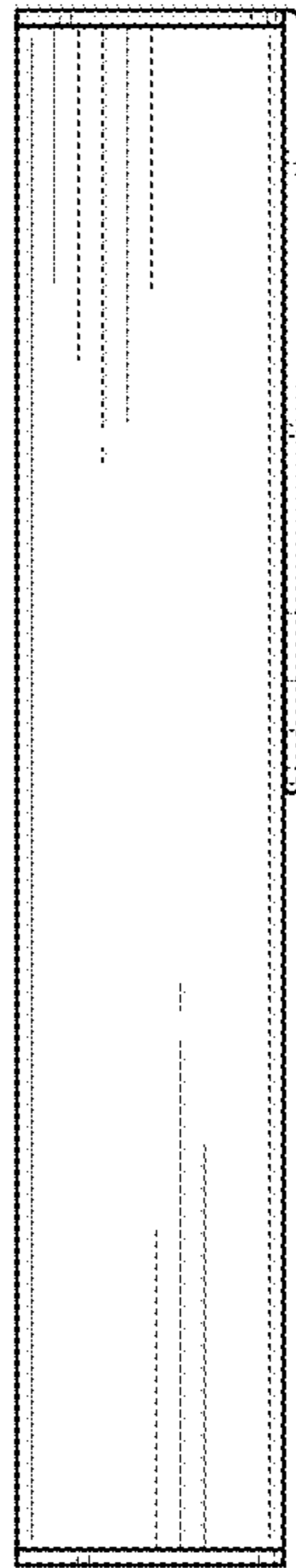

FIG. 13

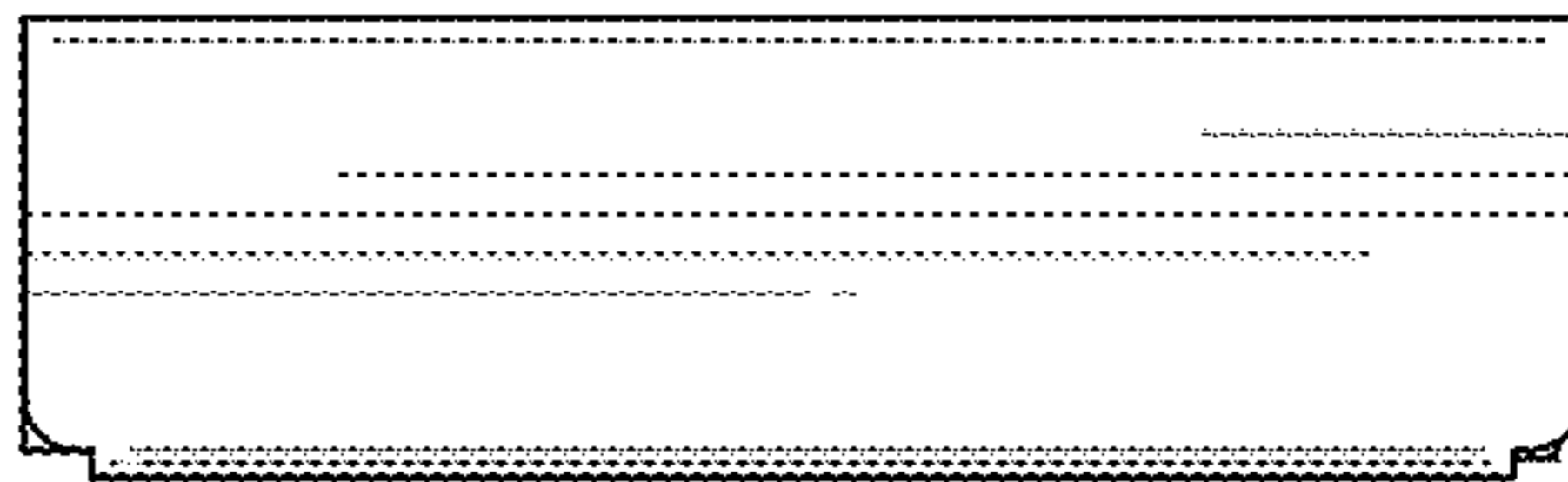

FIG. 14

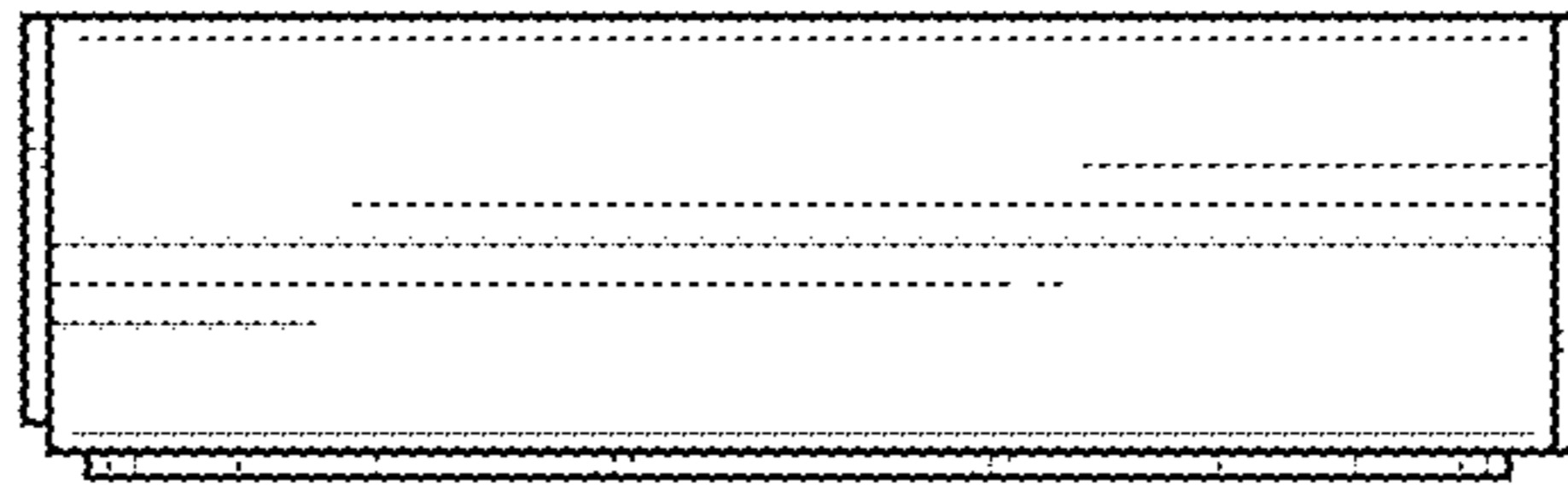

FIG. 15

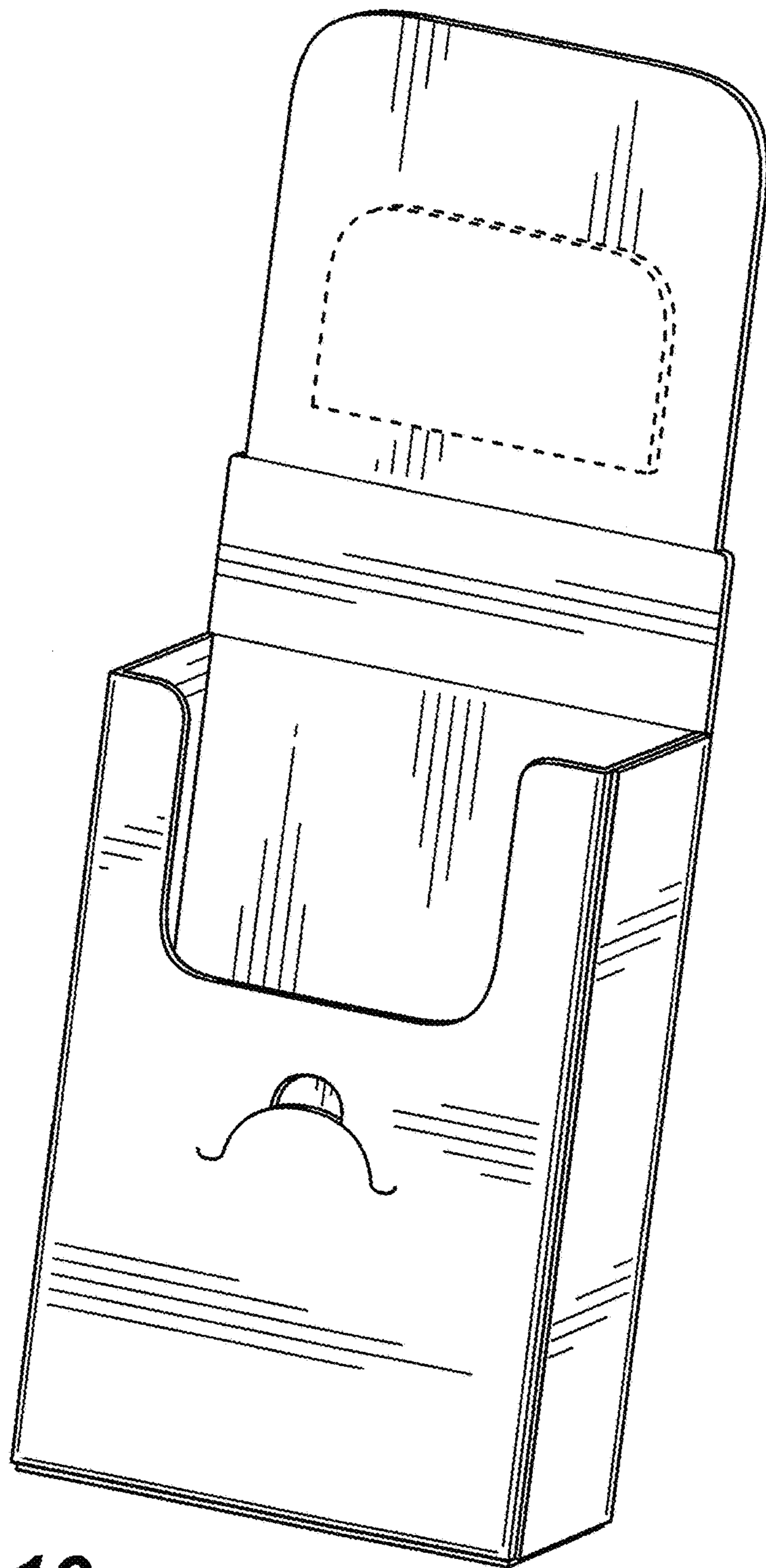

FIG. 16

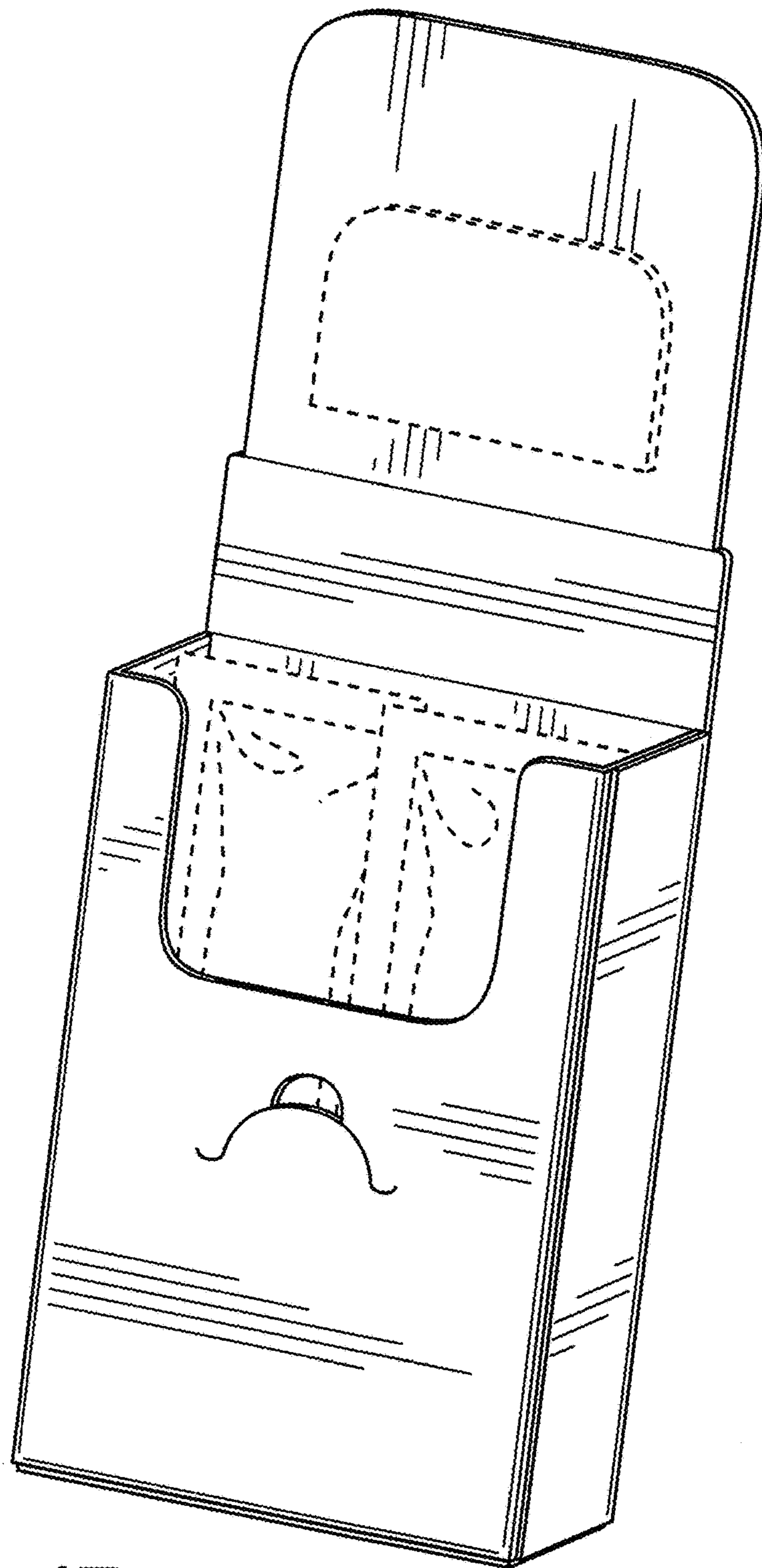

FIG. 17

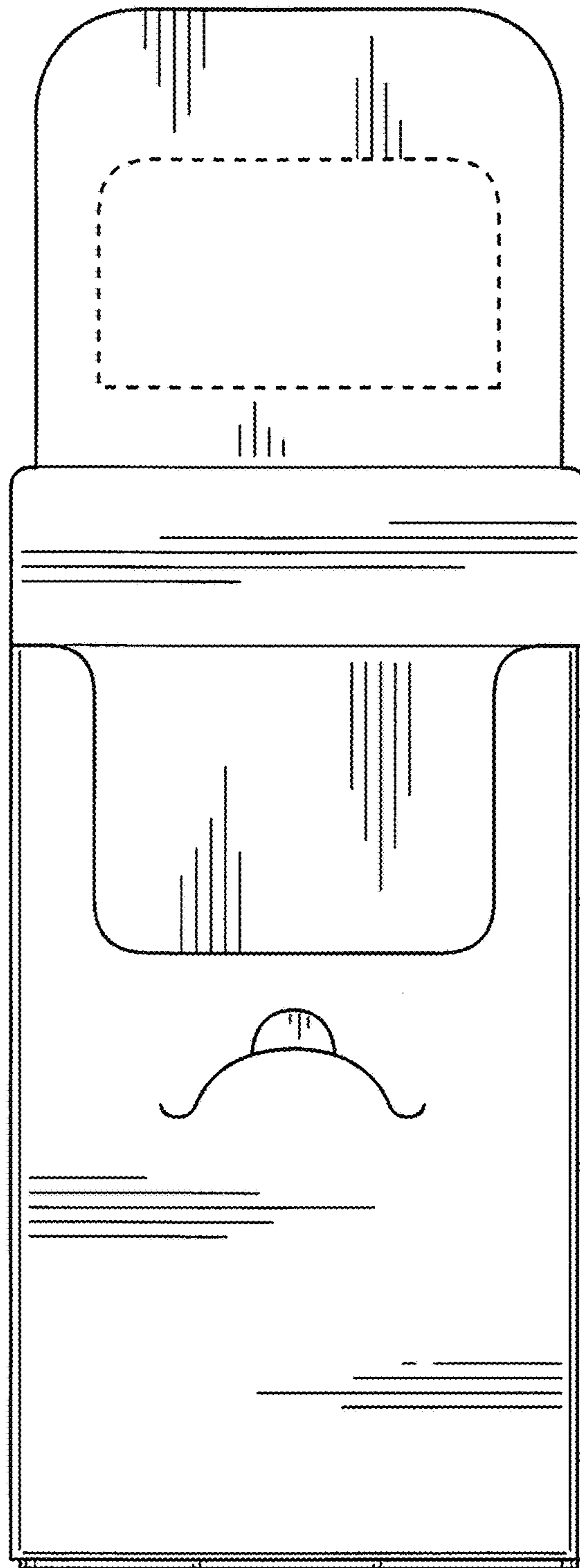

FIG. 18

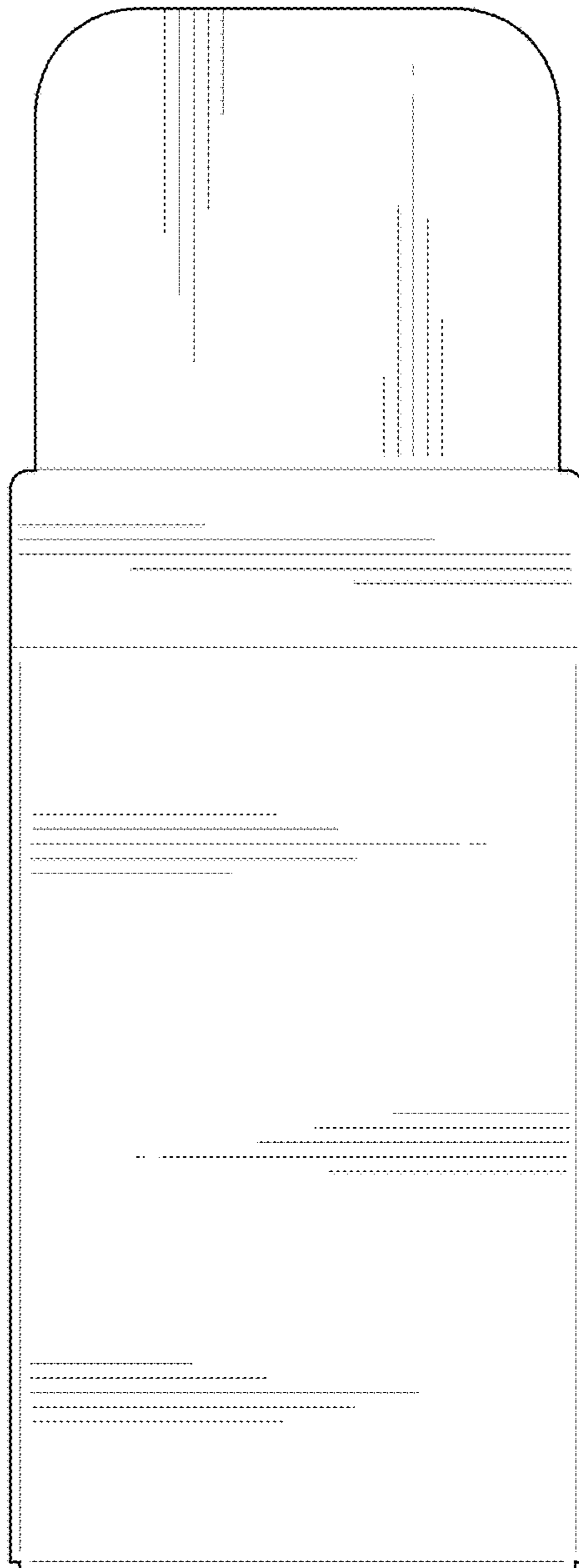

FIG. 19

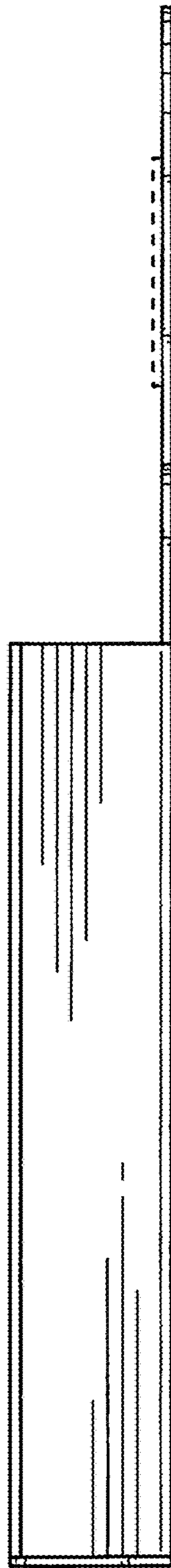

FIG. 20

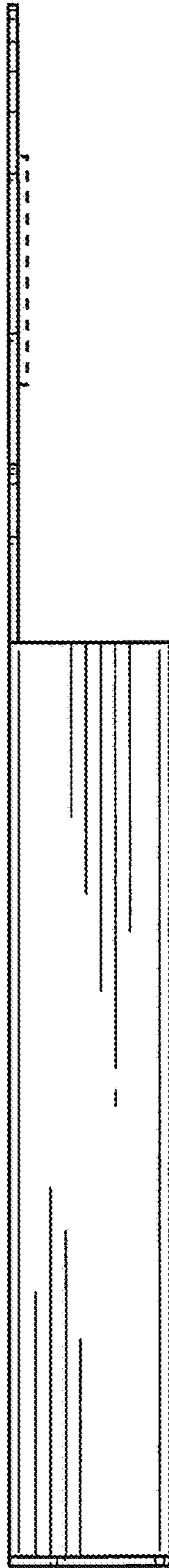

FIG. 21

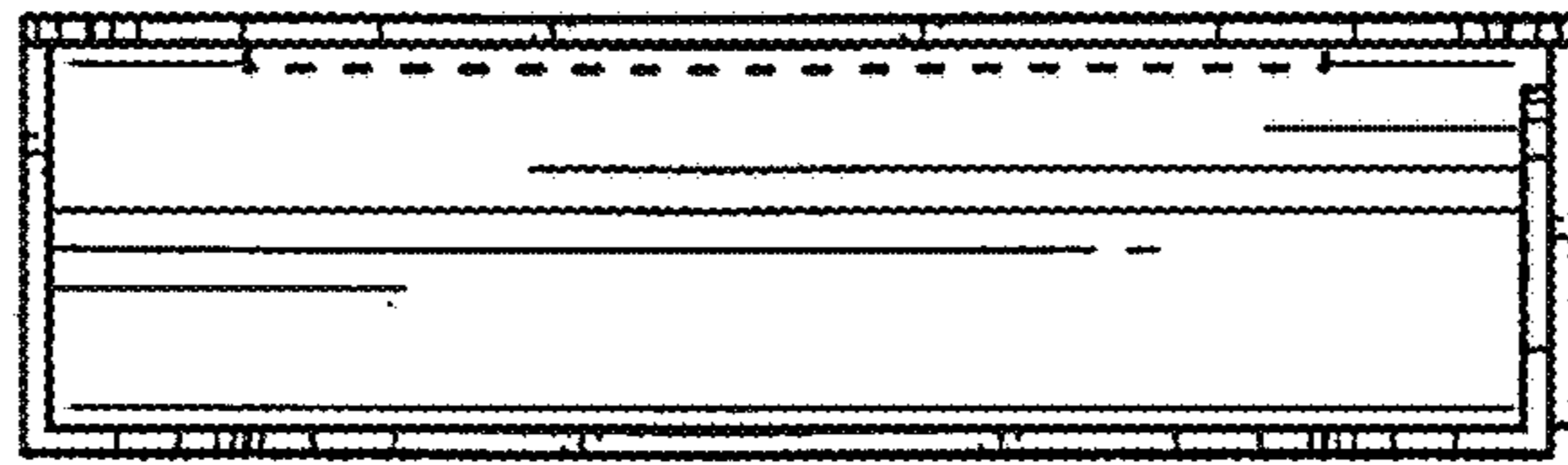

FIG. 22

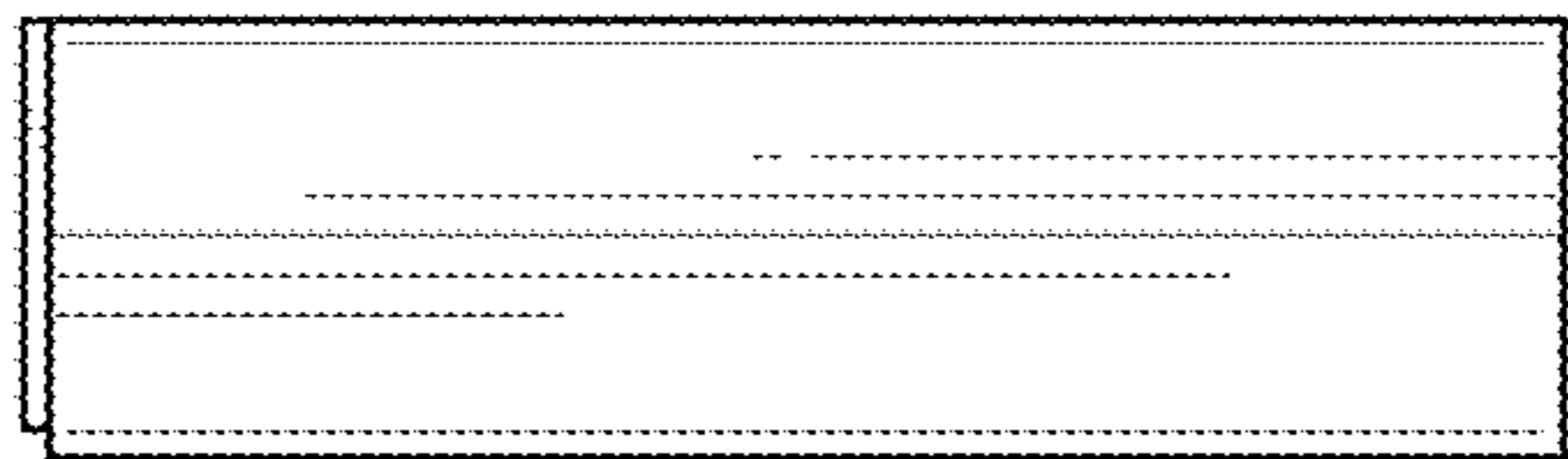

FIG. 23

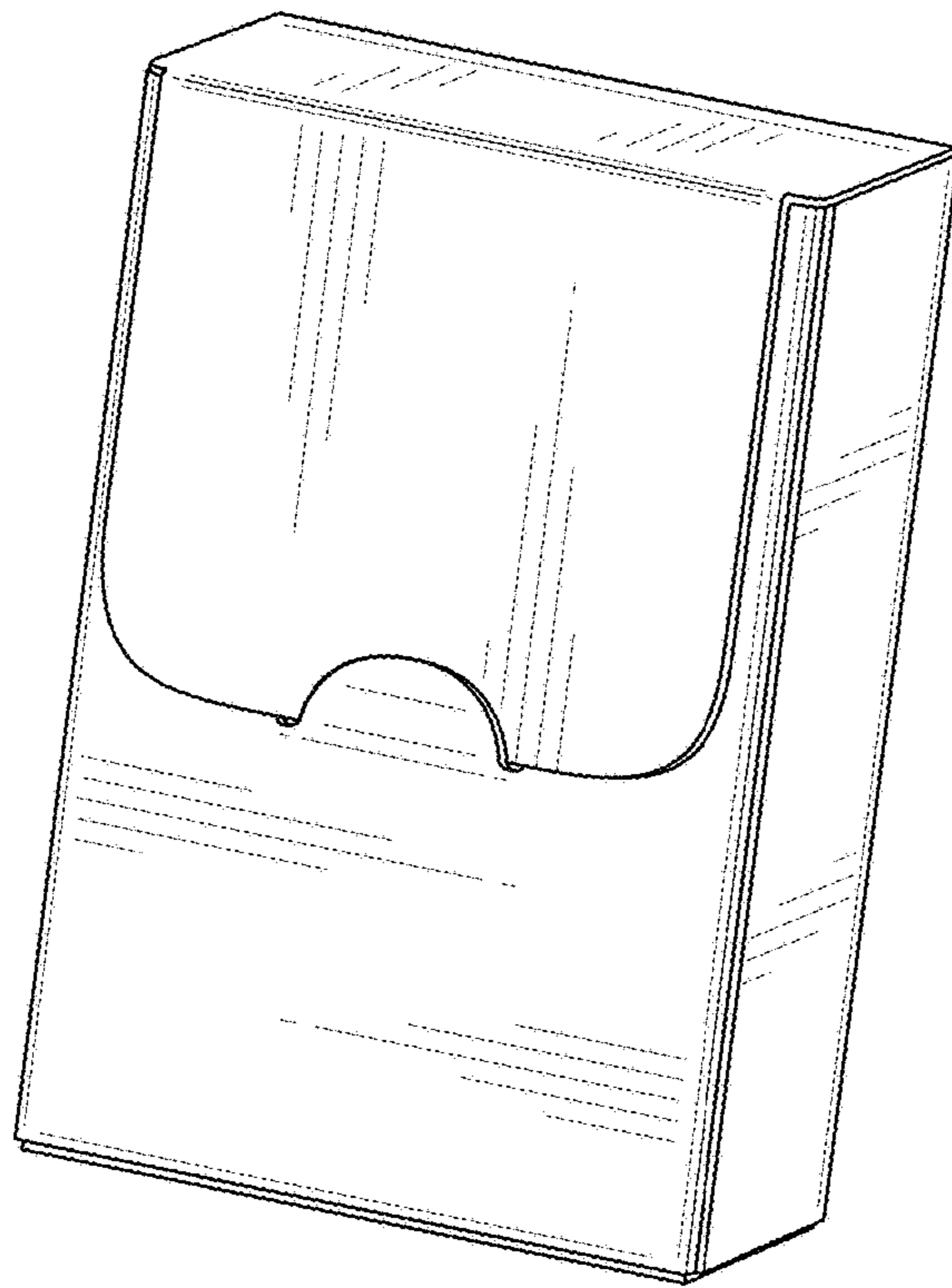

FIG. 24

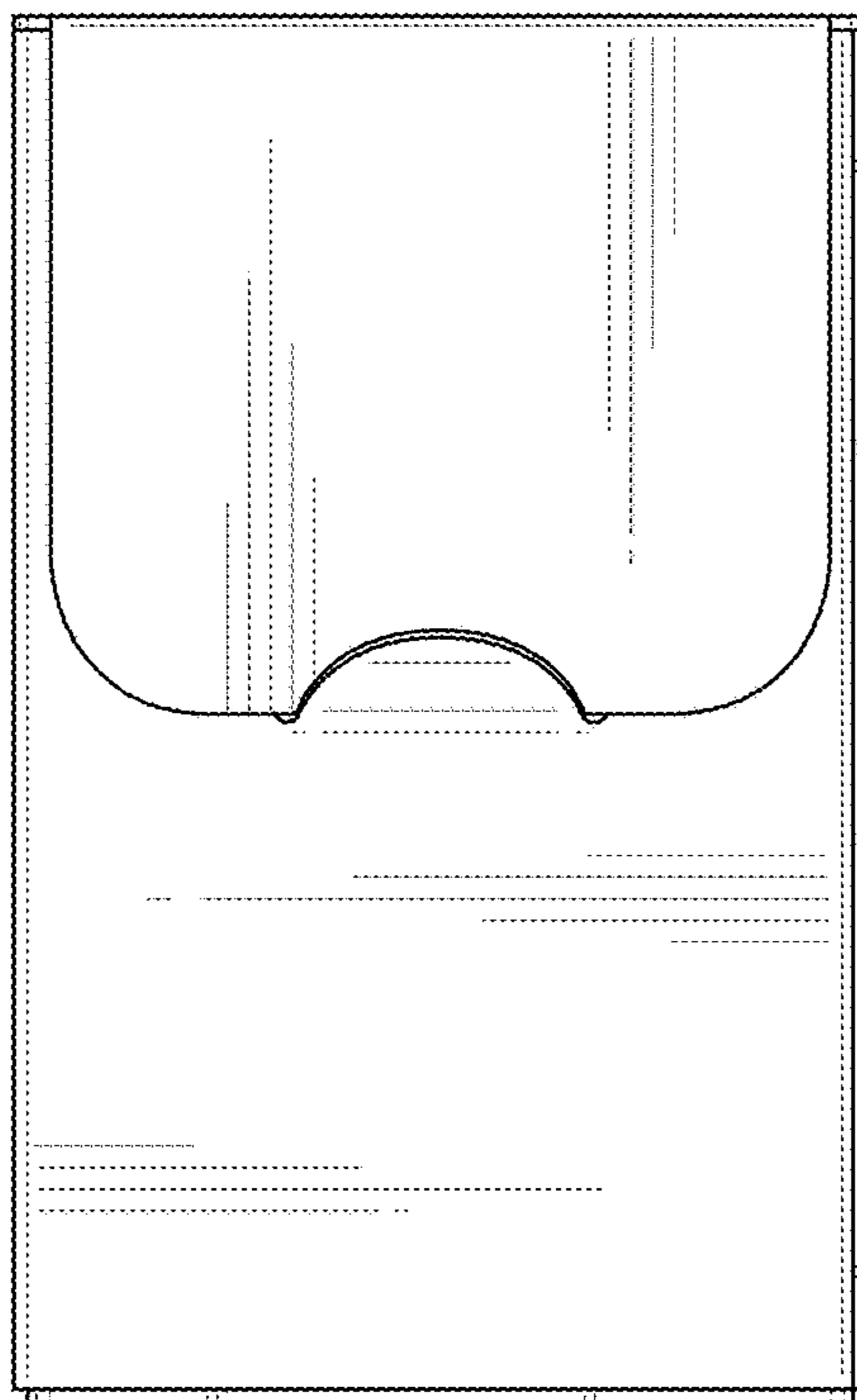

FIG. 25

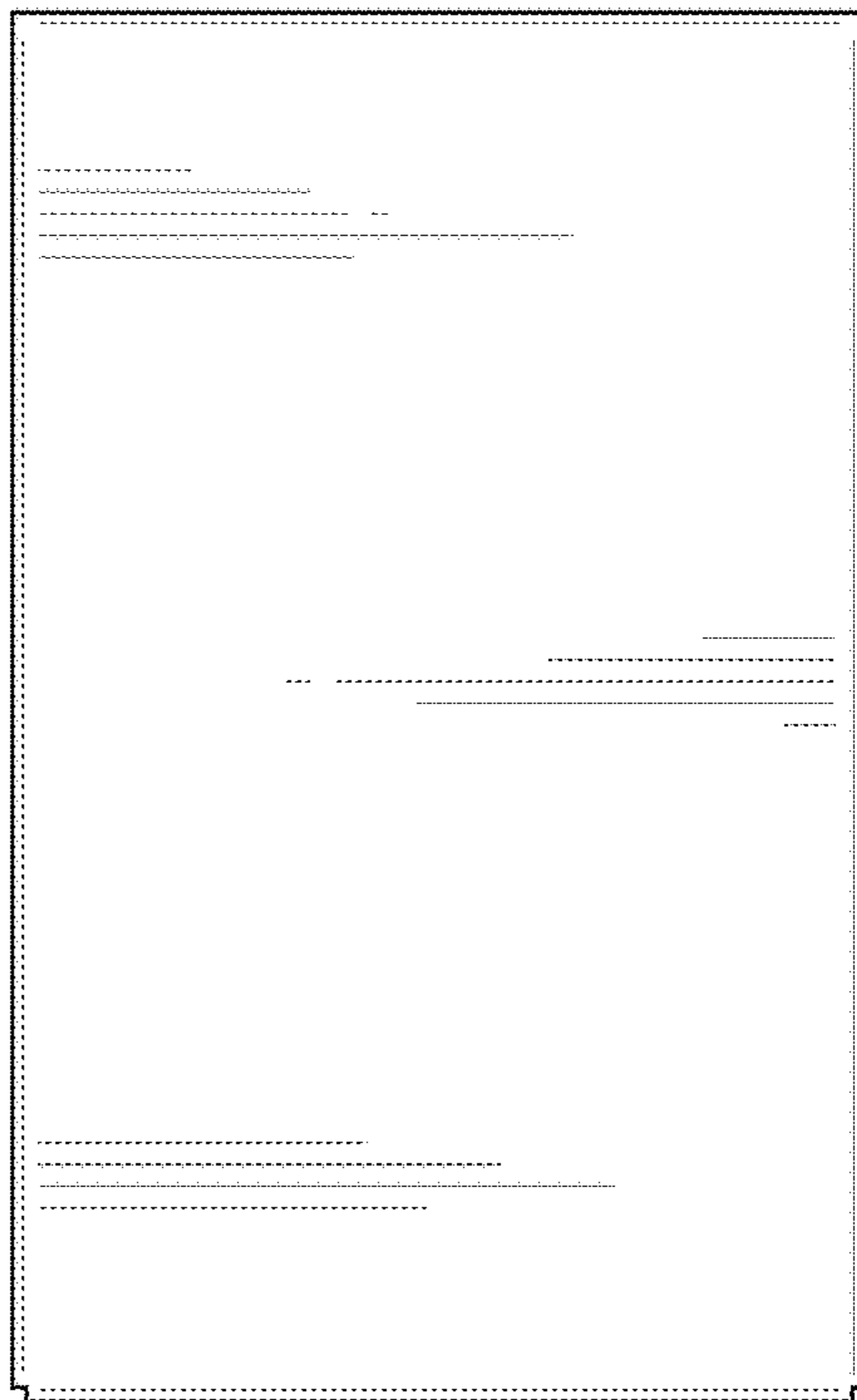

FIG. 26

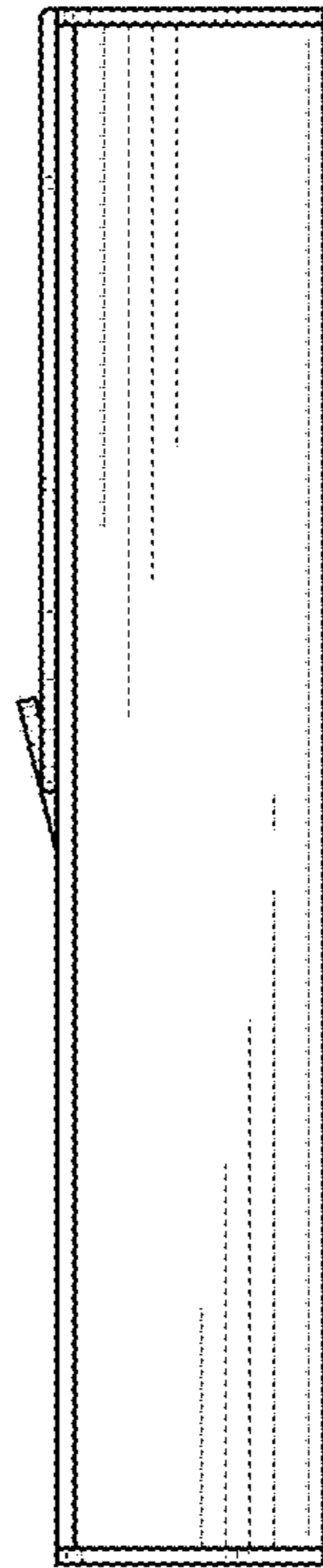

FIG. 27

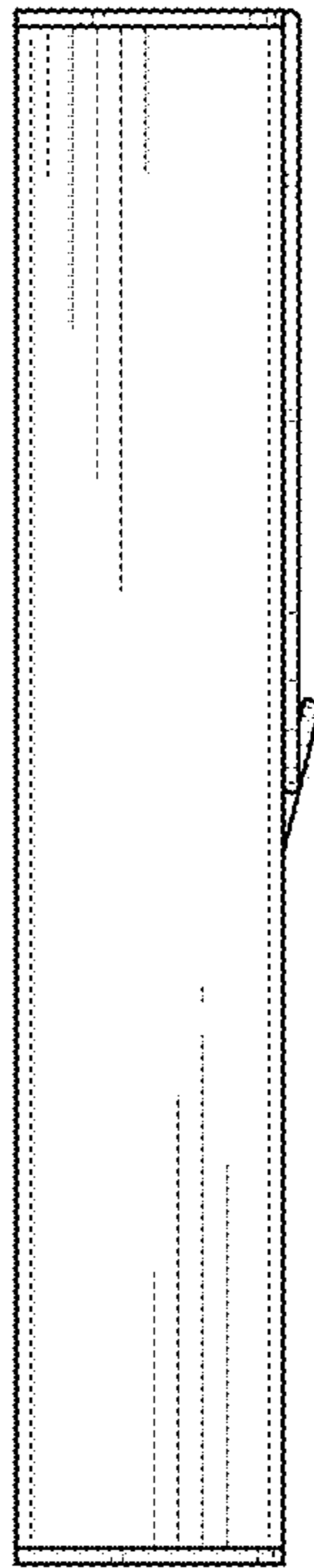

FIG. 28

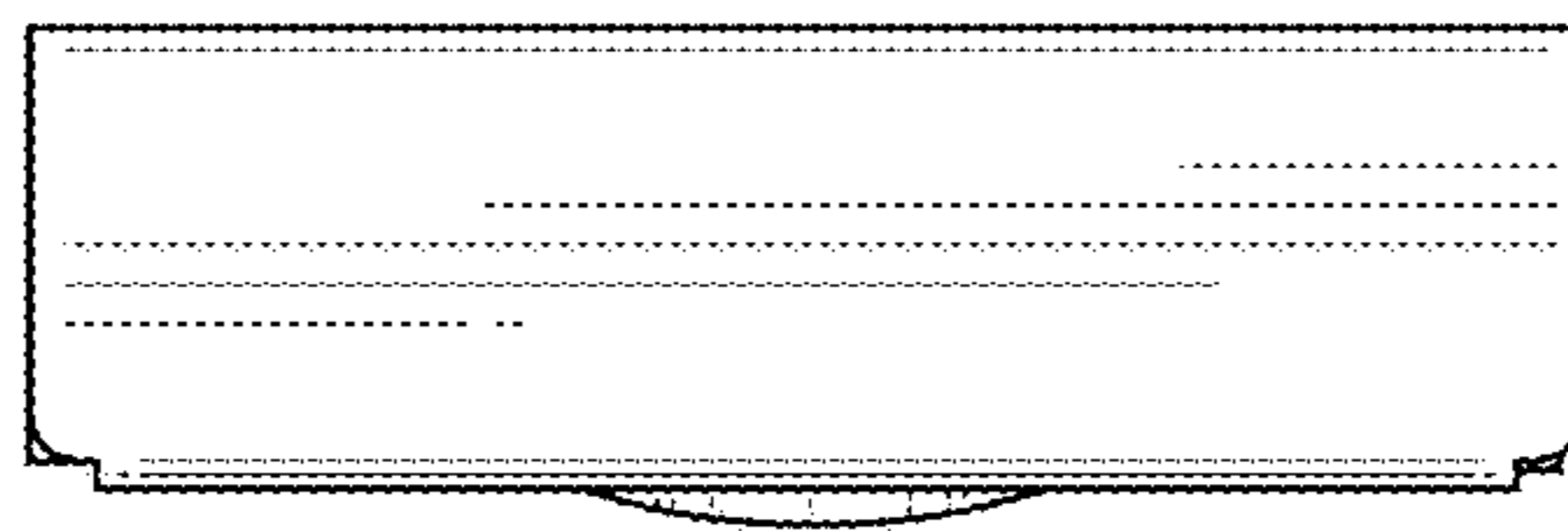

FIG. 29

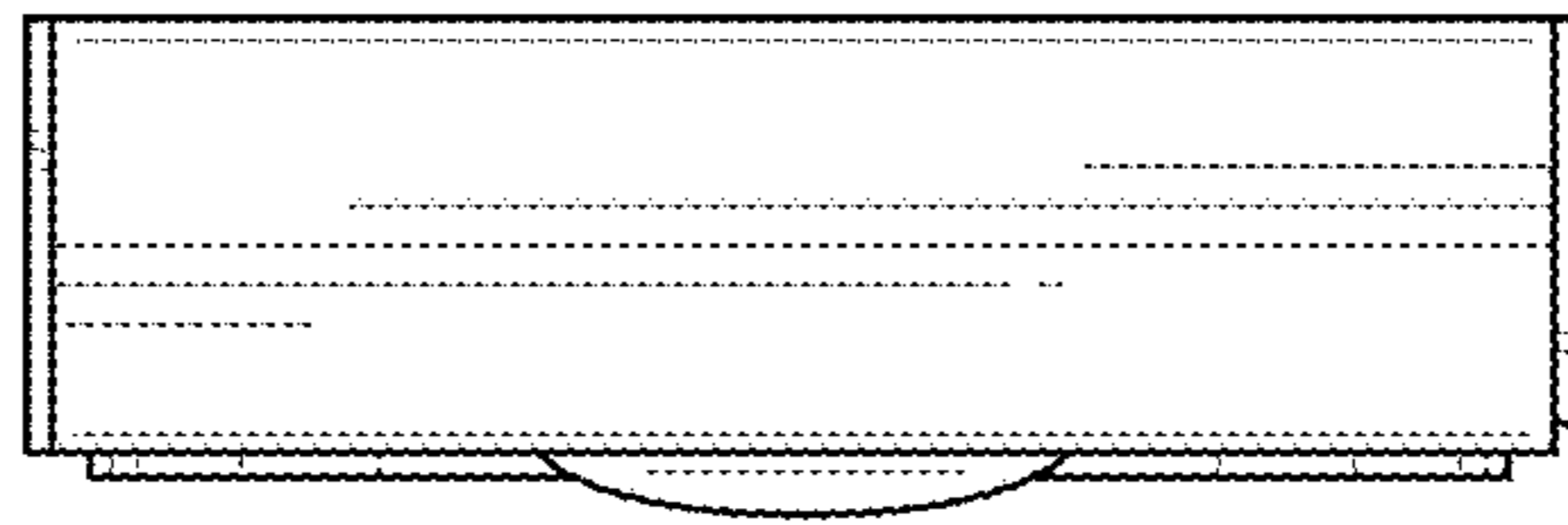

FIG. 30