

US00D850617S

(12) **United States Design Patent** (10) **Patent No.:** **US D850,617 S**
Shelton, IV et al. (45) **Date of Patent:** **** Jun. 4, 2019**

(54) **SURGICAL FASTENER CARTRIDGE**

(71) Applicant: **Ethicon Endo-Surgery, LLC**,
Guaynabo, PR (US)

(72) Inventors: **Frederick E. Shelton, IV**, Hillsboro,
OH (US); **Jason L. Harris**, Lebanon,
OH (US); **Gregory J. Bakos**, Mason,
OH (US)

(73) Assignee: **Ethicon LLC**, Guaynabo, PR (US)

(**) Term: **15 Years**

(21) Appl. No.: **29/569,264**

(22) Filed: **Jun. 24, 2016**

(51) **LOC (11) Cl.** **24-02**

(52) **U.S. Cl.**
USPC **D24/145**

(58) **Field of Classification Search**
USPC D24/145

CPC . A61B 17/105; A61B 17/068; A61B 17/0682;
A61B 17/064; A61B 17/072; A61B
17/07207; A61B 2017/07271; A61B
2017/07278; A61B 2017/07228; A61B
2017/07235; A61B 2017/07242; A61B
2017/07285; A61B 2017/07292

See application file for complete search history.

(56) **References Cited**

U.S. PATENT DOCUMENTS

66,052 A 6/1867 Smith
662,587 A 11/1900 Blake
670,748 A 3/1901 Weddeler

(Continued)

FOREIGN PATENT DOCUMENTS

AU 2008207624 A1 3/2009
AU 2010214687 A1 9/2010

(Continued)

OTHER PUBLICATIONS

“Biomedical Coatings,” Fort Wayne Metals, Research Products Corporation, obtained online at www.fwmetals.com on Jun. 21,2010 (1 page).

(Continued)

Primary Examiner — Wan Laymon

(57) **CLAIM**

The ornamental design for a surgical fastener cartridge, as shown and described.

DESCRIPTION

The Applicant of the present application owns the following U.S. Design Patent Applications that were filed on Jun. 24, 2016, which are each herein incorporated by reference in their respective entireties:

U.S. Design patent application Ser. No. 29/569,218, entitled Surgical Fastener;

U.S. Design patent application Ser. No. 29/569,227, entitled Surgical Fastener; and

U.S. Design patent application Ser. No. 29/569,259, entitled Surgical Fastener Cartridge.

FIG. 1 is a perspective view of a surgical fastener cartridge. FIG. 2 is a top plan view of the surgical fastener cartridge of FIG. 1.

FIG. 3 is a bottom plan view of the surgical fastener cartridge of FIG. 1.

FIG. 4 is a front elevation view of the surgical fastener cartridge of FIG. 1.

FIG. 5 is an enlarged left elevation view of the surgical fastener cartridge of FIG. 1; and,

FIG. 6 is an enlarged right elevation view of the surgical fastener cartridge of FIG. 1.

In all figures, broken lines illustrate environmental structures and/or boundaries. The broken lines form no part of the claimed design.

1 Claim, 4 Drawing Sheets

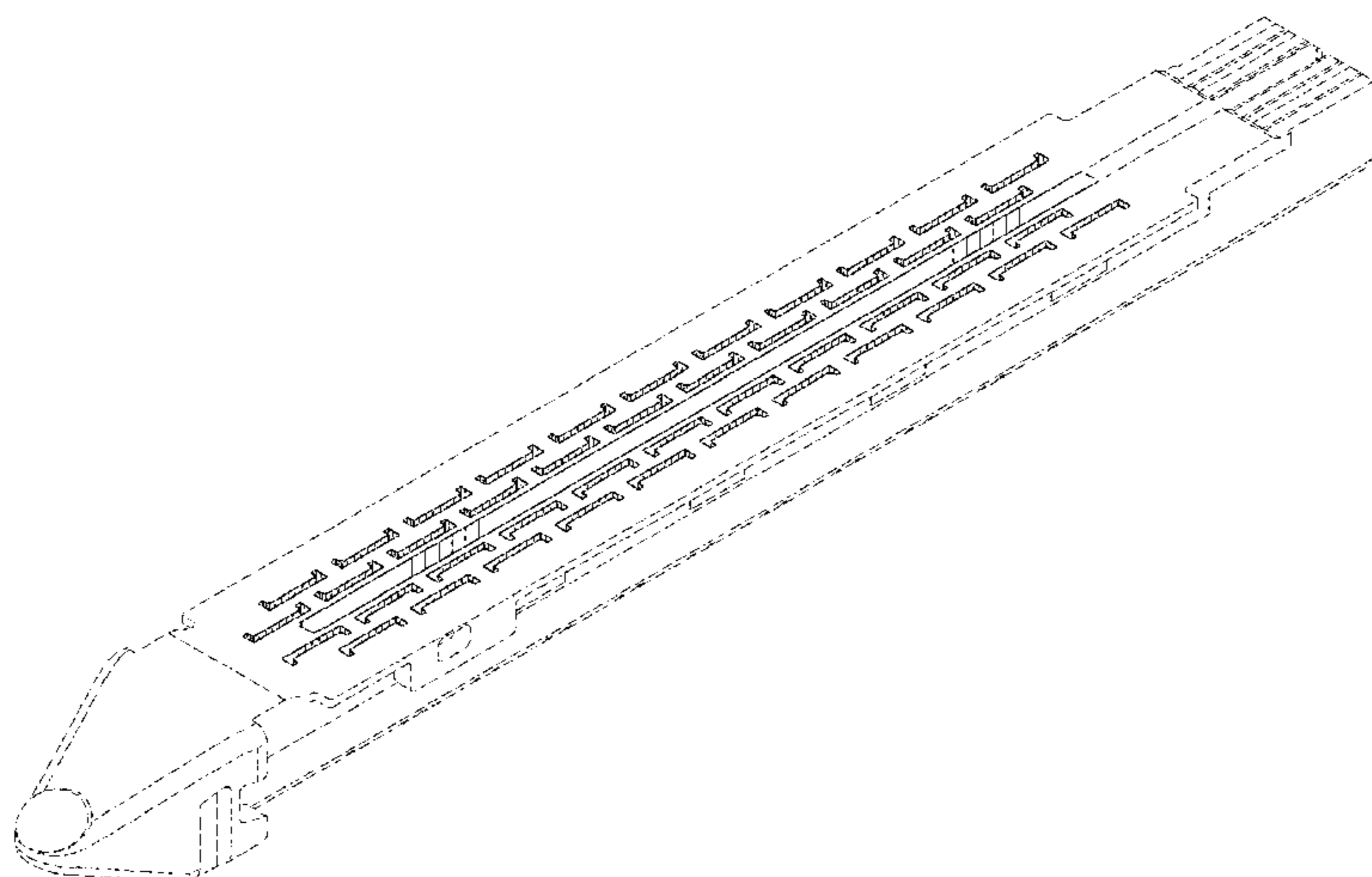

(56)

References Cited

U.S. PATENT DOCUMENTS

951,393 A	3/1910	Hahn	4,380,312 A	4/1983	Landrus
1,306,107 A	6/1919	Elliott	4,382,326 A	5/1983	Rabuse
1,314,601 A	9/1919	McCaskey	4,383,634 A	5/1983	Green
1,677,337 A	7/1928	Grove	4,393,728 A	7/1983	Larson et al.
1,794,907 A	3/1931	Kelly	4,396,139 A	8/1983	Hall et al.
2,037,727 A	4/1936	La Chapelle	4,397,311 A	8/1983	Kanshin et al.
2,132,295 A	10/1938	Hawkins	4,402,445 A	9/1983	Green
2,161,632 A	6/1939	Nattenheimer	4,408,692 A	10/1983	Sigel et al.
2,211,117 A	8/1940	Hess	4,409,057 A	10/1983	Molenda et al.
2,214,870 A	9/1940	West	4,415,112 A	11/1983	Green
2,318,379 A	5/1943	Davis et al.	4,416,276 A	11/1983	Newton et al.
2,441,096 A	5/1948	Happe	4,428,376 A	1/1984	Mericle
2,475,322 A	7/1949	Horton et al.	4,429,695 A	2/1984	Green
2,526,902 A	10/1950	Rublee	4,434,796 A	3/1984	Karapetian et al.
2,578,686 A	12/1951	Fish	4,438,659 A	3/1984	Desplats
2,674,149 A	4/1954	Benson	4,442,964 A	4/1984	Becht
2,711,461 A	6/1955	Happe	4,448,194 A	5/1984	DiGiovanni et al.
2,804,848 A	9/1957	O'Farrell et al.	4,451,743 A	5/1984	Suzuki et al.
2,808,482 A	10/1957	Zanichkowsky et al.	4,454,887 A	6/1984	Kruger
2,853,074 A	9/1958	Olson	4,467,805 A	8/1984	Fukuda
2,959,974 A	11/1960	Emrick	4,473,077 A	9/1984	Noiles et al.
3,032,769 A	5/1962	Palmer	4,475,679 A	10/1984	Fleury, Jr.
3,060,972 A	10/1962	Sheldon	4,485,816 A	12/1984	Krumme
3,075,062 A	1/1963	Iaccarino	4,486,928 A	12/1984	Tucker et al.
3,078,465 A	2/1963	Bobrov	4,488,523 A	12/1984	Shichman
3,079,606 A	3/1963	Bobrov et al.	4,489,875 A	12/1984	Crawford et al.
3,166,072 A	1/1965	Sullivan, Jr.	4,499,895 A	2/1985	Takayama
3,196,869 A	7/1965	Scholl	4,500,024 A	2/1985	DiGiovanni et al.
3,204,731 A	9/1965	Bent et al.	4,505,272 A	3/1985	Utyamyshev et al.
3,266,494 A	8/1966	Brownrigg et al.	4,505,273 A	3/1985	Braun et al.
3,269,630 A	8/1966	Fleischer	4,505,414 A	3/1985	Filipi
3,275,211 A	9/1966	Hirsch et al.	4,506,671 A	3/1985	Green
3,317,103 A	5/1967	Cullen et al.	4,520,817 A	6/1985	Green
3,499,591 A	3/1970	Green	4,522,327 A	6/1985	Korthoff et al.
3,551,987 A	1/1971	Wilkinson	4,526,174 A	7/1985	Froehlich
3,583,393 A	6/1971	Takahashi	4,527,724 A	7/1985	Chow et al.
3,662,939 A	5/1972	Bryan	4,530,453 A	7/1985	Green
3,717,294 A	2/1973	Green	4,531,522 A	7/1985	Bedi et al.
3,799,151 A	3/1974	Fukaumi et al.	4,532,927 A	8/1985	Miksza, Jr.
RE28,932 E	8/1976	Noiles et al.	4,548,202 A	10/1985	Duncan
4,060,089 A	11/1977	Noiles	4,565,109 A	1/1986	Tsay
4,106,446 A	8/1978	Yamada et al.	4,565,189 A	1/1986	Mabuchi
4,108,211 A	8/1978	Tanaka	4,566,620 A	1/1986	Green et al.
4,111,206 A	9/1978	Vishnevsky et al.	4,569,469 A	2/1986	Mongeon et al.
4,129,059 A	12/1978	Van Eck	4,571,213 A	2/1986	Ishimoto
4,169,990 A	10/1979	Lerdman	4,573,468 A	3/1986	Conta et al.
4,180,285 A	12/1979	Reneau	4,573,469 A	3/1986	Golden et al.
4,198,734 A	4/1980	Brumlik	4,573,622 A	3/1986	Green et al.
4,198,982 A	4/1980	Fortner et al.	4,576,167 A	3/1986	Noiles
4,207,898 A	6/1980	Becht	4,580,712 A	4/1986	Green
4,213,562 A	7/1980	Garrett et al.	4,585,153 A	4/1986	Failla et al.
4,226,242 A	10/1980	Jarvik	4,589,416 A	5/1986	Green
4,241,861 A	12/1980	Fleischer	4,591,085 A	5/1986	Di Giovanni
4,244,372 A	1/1981	Kapitanov et al.	4,597,753 A	7/1986	Turley
4,250,436 A	2/1981	Weissman	4,600,037 A	7/1986	Hatten
4,261,244 A	4/1981	Becht et al.	4,604,786 A	8/1986	Howie, Jr.
4,272,002 A	6/1981	Moshofsky	4,605,001 A	8/1986	Rothfuss et al.
4,272,662 A	6/1981	Simpson	4,605,004 A	8/1986	Di Giovanni et al.
4,274,304 A	6/1981	Curtiss	4,606,343 A	8/1986	Conta et al.
4,275,813 A	6/1981	Noiles	4,607,638 A	8/1986	Crainich
4,289,133 A	9/1981	Rothfuss	4,608,981 A	9/1986	Rothfuss et al.
4,296,654 A	10/1981	Mercer	4,610,250 A	9/1986	Green
4,304,236 A	12/1981	Conta et al.	4,610,383 A	9/1986	Rothfuss et al.
4,305,539 A	12/1981	Korolkov et al.	D286,180 S	10/1986	Korthoff
4,312,685 A	1/1982	Riedl	D286,441 S	10/1986	Korthoff et al.
4,317,451 A	3/1982	Cerwin et al.	D286,442 S	10/1986	Korthoff et al.
4,319,576 A	3/1982	Rothfuss	4,619,262 A	10/1986	Taylor
4,321,002 A	3/1982	Froehlich	4,619,391 A	10/1986	Sharkany et al.
4,328,839 A	5/1982	Lyons et al.	4,628,459 A	12/1986	Shinohara et al.
4,331,277 A	5/1982	Green	4,629,107 A	12/1986	Fedotov et al.
4,340,331 A	7/1982	Savino	4,632,290 A	12/1986	Green et al.
4,347,450 A	8/1982	Colligan	4,633,874 A	1/1987	Chow et al.
4,349,028 A	9/1982	Green	4,634,419 A	1/1987	Kreizman et al.
4,353,371 A	10/1982	Cosman	4,641,076 A	2/1987	Linden
4,379,457 A	4/1983	Gravener et al.	4,643,731 A	2/1987	Eckenhoff
			4,646,722 A	3/1987	Silverstein et al.
			4,655,222 A	4/1987	Florez et al.
			4,662,555 A	5/1987	Thornton
			4,663,874 A	5/1987	Sano et al.

(56)

References Cited

U.S. PATENT DOCUMENTS

4,664,305 A	5/1987	Blake, III et al.	5,002,553 A	3/1991	Shiber
4,665,916 A	5/1987	Green	5,005,754 A	4/1991	Van Overloop
4,667,674 A	5/1987	Korthoff et al.	5,009,661 A	4/1991	Michelson
4,669,647 A	6/1987	Storace	5,014,899 A	5/1991	Presty et al.
4,671,445 A	6/1987	Barker et al.	5,015,227 A	5/1991	Broadwin et al.
4,676,245 A	6/1987	Fukuda	5,018,515 A	5/1991	Gilman
4,684,051 A	8/1987	Akopov et al.	5,018,657 A	5/1991	Pedlick et al.
4,693,248 A	9/1987	Failla	5,024,671 A	6/1991	Tu et al.
4,700,703 A	10/1987	Resnick et al.	5,027,834 A	7/1991	Pruitt
4,708,141 A	11/1987	Inoue et al.	5,031,814 A	7/1991	Tompkins et al.
4,709,120 A	11/1987	Pearson	5,035,040 A	7/1991	Kerrigan et al.
4,715,520 A	12/1987	Roehr, Jr. et al.	5,038,109 A	8/1991	Goble et al.
4,719,917 A	1/1988	Barrows et al.	5,040,715 A	8/1991	Green et al.
4,727,308 A	2/1988	Huljak et al.	5,042,707 A	8/1991	Taheri
4,728,020 A	3/1988	Green et al.	5,053,047 A	10/1991	Yoon
4,728,876 A	3/1988	Mongeon et al.	5,061,269 A	10/1991	Muller
4,729,260 A	3/1988	Dudden	5,062,563 A	11/1991	Green et al.
4,730,726 A	3/1988	Holzwarth	5,065,929 A	11/1991	Schulze et al.
4,741,336 A	5/1988	Failla et al.	5,071,052 A	12/1991	Rodak et al.
4,743,214 A	5/1988	Tai-Cheng	5,071,430 A	12/1991	de Salis et al.
4,747,820 A	5/1988	Hornlein et al.	5,074,454 A	12/1991	Peters
4,750,902 A	6/1988	Wuchinich et al.	5,079,006 A	1/1992	Urquhart
4,752,024 A	6/1988	Green et al.	5,080,556 A	1/1992	Carreno
4,754,909 A	7/1988	Barker et al.	5,083,695 A	1/1992	Foslien et al.
4,767,044 A	8/1988	Green	5,084,057 A	1/1992	Green et al.
D297,764 S *	9/1988	Hunt D24/145	5,088,979 A	2/1992	Filipi et al.
4,773,420 A	9/1988	Green	5,088,997 A	2/1992	Delahuerga et al.
4,777,780 A	10/1988	Holzwarth	5,089,009 A	2/1992	Green
4,781,186 A	11/1988	Simpson et al.	5,094,247 A	3/1992	Hernandez et al.
4,787,387 A	11/1988	Burbank, III et al.	5,100,420 A	3/1992	Green et al.
4,790,225 A	12/1988	Moody et al.	5,104,025 A	4/1992	Main et al.
4,802,478 A	2/1989	Powell	5,104,397 A	4/1992	Vasconcelos et al.
4,805,617 A	2/1989	Bedi et al.	5,106,008 A	4/1992	Tompkins et al.
4,805,823 A	2/1989	Rothfuss	5,108,368 A	4/1992	Hammerslag et al.
4,809,695 A	3/1989	Gwathmey et al.	5,111,987 A	5/1992	Moeinzadeh et al.
4,815,460 A	3/1989	Porat et al.	5,116,349 A	5/1992	Aranyi
4,817,847 A	4/1989	Redtenbacher et al.	D327,323 S	6/1992	Hunt
4,819,853 A	4/1989	Green	5,122,156 A	6/1992	Granger et al.
4,821,939 A	4/1989	Green	5,129,570 A	7/1992	Schulze et al.
4,827,911 A	5/1989	Broadwin et al.	5,137,198 A	8/1992	Nobis et al.
4,830,855 A	5/1989	Stewart	5,139,513 A	8/1992	Segato
4,834,720 A	5/1989	Blinkhorn	5,141,144 A	8/1992	Foslien et al.
4,844,068 A	7/1989	Arata et al.	5,142,932 A	9/1992	Moya et al.
4,848,637 A	7/1989	Pruitt	5,155,941 A	10/1992	Takahashi et al.
4,865,030 A	9/1989	Polyak	5,156,315 A	10/1992	Green et al.
4,869,414 A	9/1989	Green et al.	5,156,609 A	10/1992	Nakao et al.
4,869,415 A	9/1989	Fox	5,156,614 A	10/1992	Green et al.
4,873,977 A	10/1989	Avant et al.	5,158,567 A	10/1992	Green
4,874,122 A	10/1989	Froelich et al.	D330,699 S	11/1992	Gill
4,880,015 A	11/1989	Nierman	5,163,598 A	11/1992	Peters et al.
4,890,613 A	1/1990	Golden et al.	5,171,247 A	12/1992	Hughett et al.
4,892,244 A	1/1990	Fox et al.	5,171,249 A	12/1992	Stefanchik et al.
4,893,622 A	1/1990	Green et al.	5,171,253 A	12/1992	Klieman
4,894,051 A	1/1990	Shiber	5,188,111 A	2/1993	Yates et al.
4,896,678 A	1/1990	Ogawa	5,190,517 A	3/1993	Zieve et al.
4,900,303 A	2/1990	Lemelson	5,190,544 A	3/1993	Chapman et al.
4,903,697 A	2/1990	Resnick et al.	5,190,560 A	3/1993	Woods et al.
4,915,100 A	4/1990	Green	5,192,288 A	3/1993	Thompson et al.
4,930,503 A	6/1990	Pruitt	5,195,968 A	3/1993	Lundquist et al.
4,930,674 A	6/1990	Barak	5,197,648 A	3/1993	Gingold
4,931,047 A	6/1990	Broadwin et al.	5,197,649 A	3/1993	Bessler et al.
4,932,960 A	6/1990	Green et al.	5,197,966 A	3/1993	Sommerkamp
4,938,408 A	7/1990	Bedi et al.	5,200,280 A	4/1993	Karasa
4,941,623 A	7/1990	Pruitt	5,201,746 A	4/1993	Shichman
4,944,443 A	7/1990	Odds et al.	5,205,459 A	4/1993	Brinkerhoff et al.
4,951,860 A	8/1990	Peters et al.	5,207,697 A	5/1993	Carusillo et al.
4,955,898 A	9/1990	Matsutani et al.	5,209,747 A	5/1993	Knoepfler
4,955,959 A	9/1990	Tompkins et al.	5,211,649 A	5/1993	Kohler et al.
4,965,709 A	10/1990	Ngo	5,211,655 A	5/1993	Hasson
4,973,274 A	11/1990	Hirukawa	5,217,457 A	6/1993	Delahuerga et al.
4,978,049 A	12/1990	Green	5,217,478 A	6/1993	Rexroth
4,978,333 A	12/1990	Broadwin et al.	5,219,111 A	6/1993	Bilotti et al.
4,986,808 A	1/1991	Broadwin et al.	5,221,036 A	6/1993	Takase
4,988,334 A	1/1991	Hornlein et al.	5,221,281 A	6/1993	Klicek
5,002,543 A	3/1991	Bradshaw et al.	5,222,963 A	6/1993	Brinkerhoff et al.
			5,222,975 A	6/1993	Crainich
			5,222,976 A	6/1993	Yoon
			5,223,675 A	6/1993	Taft
			D338,729 S	8/1993	Sprecklemeier et al.

(56)

References Cited

U.S. PATENT DOCUMENTS

5,234,447 A	8/1993	Kaster et al.	5,360,305 A	11/1994	Kerrigan
5,236,440 A	8/1993	Hlavacek	5,360,428 A	11/1994	Hutchinson, Jr.
5,239,981 A	8/1993	Anaplotis	5,364,001 A	11/1994	Bryan
5,240,163 A	8/1993	Stein et al.	5,364,003 A	11/1994	Williamson, IV
5,242,457 A	9/1993	Akopov et al.	5,366,133 A	11/1994	Geiste
5,244,462 A	9/1993	Delahuerga et al.	5,366,134 A	11/1994	Green et al.
5,246,156 A	9/1993	Rothfuss et al.	5,366,479 A	11/1994	McGarry et al.
5,246,443 A	9/1993	Mai	5,368,015 A	11/1994	Wilk
5,253,793 A	10/1993	Green et al.	5,368,592 A	11/1994	Stern et al.
5,258,009 A	11/1993	Connors	5,370,645 A	12/1994	Klicek et al.
5,258,012 A	11/1993	Luscombe et al.	5,372,124 A	12/1994	Takayama et al.
5,259,366 A	11/1993	Reydel et al.	5,372,596 A	12/1994	Klicek et al.
5,260,637 A	11/1993	Pizzi	5,372,602 A	12/1994	Burke
5,263,629 A	11/1993	Trumbull et al.	5,374,277 A	12/1994	Hassler
5,263,973 A	11/1993	Cook	5,376,095 A	12/1994	Ortiz
5,264,218 A	11/1993	Rogozinski	5,379,933 A	1/1995	Green et al.
5,268,622 A	12/1993	Philipp	5,381,649 A	1/1995	Webb
5,271,543 A	12/1993	Grant et al.	5,381,782 A	1/1995	DeLaRama et al.
5,271,544 A	12/1993	Fox et al.	5,382,247 A	1/1995	Cimino et al.
RE34,519 E	1/1994	Fox et al.	5,383,880 A	1/1995	Hooven
5,275,323 A	1/1994	Schulze et al.	5,383,881 A	1/1995	Green et al.
5,275,608 A	1/1994	Forman et al.	5,383,888 A	1/1995	Zvenyatsky et al.
5,279,416 A	1/1994	Malec et al.	5,383,895 A	1/1995	Holmes et al.
5,281,216 A	1/1994	Klicek	5,389,098 A	2/1995	Tsuruta et al.
5,282,806 A	2/1994	Haber et al.	5,389,104 A	2/1995	Hahnen et al.
5,282,829 A	2/1994	Hermes	5,391,180 A	2/1995	Tovey et al.
5,284,128 A	2/1994	Hart	5,392,979 A	2/1995	Green et al.
5,285,945 A	2/1994	Brinkerhoff et al.	5,395,030 A	3/1995	Kuramoto et al.
5,289,963 A	3/1994	McGarry et al.	5,395,033 A	3/1995	Byrne et al.
5,290,271 A	3/1994	Jernberg	5,395,034 A	3/1995	Allen et al.
5,292,053 A	3/1994	Bilotti et al.	5,395,312 A	3/1995	Desai
5,297,714 A	3/1994	Kramer	5,395,384 A	3/1995	Duthoit et al.
5,304,204 A	4/1994	Bregen	5,397,046 A	3/1995	Savage et al.
D347,474 S	5/1994	Olson	5,397,324 A	3/1995	Carroll et al.
5,307,976 A	5/1994	Olson et al.	5,403,043 A	4/1995	Smet
5,309,927 A	5/1994	Welch	5,403,312 A	4/1995	Yates et al.
5,312,023 A	5/1994	Green et al.	5,405,072 A	4/1995	Zlock et al.
5,312,024 A	5/1994	Grant et al.	5,405,073 A	4/1995	Porter
5,312,329 A	5/1994	Beaty et al.	5,405,344 A	4/1995	Williamson et al.
5,314,424 A	5/1994	Nicholas	5,405,360 A	4/1995	Tovey
5,314,445 A	5/1994	Heidmueller nee Degwitz et al.	5,407,293 A	4/1995	Crainich
5,314,466 A	5/1994	Stern et al.	5,409,498 A	4/1995	Braddock et al.
5,318,221 A	6/1994	Green et al.	D357,981 S	5/1995	Green et al.
D348,930 S	7/1994	Olson	5,411,481 A	5/1995	Allen et al.
5,329,923 A	7/1994	Lundquist	5,411,508 A	5/1995	Bessler et al.
5,330,487 A	7/1994	Thornton et al.	5,413,107 A	5/1995	Oakley et al.
5,330,502 A	7/1994	Hassler et al.	5,413,267 A	5/1995	Solyntjes et al.
5,332,142 A	7/1994	Robinson et al.	5,413,268 A	5/1995	Green et al.
5,333,422 A	8/1994	Warren et al.	5,413,272 A	5/1995	Green et al.
5,333,772 A	8/1994	Rothfuss et al.	5,413,573 A	5/1995	Koivukangas
5,333,773 A	8/1994	Main et al.	5,415,334 A	5/1995	Williamson et al.
5,334,183 A	8/1994	Wuchinich	5,415,335 A	5/1995	Knodell, Jr.
5,336,232 A	8/1994	Green et al.	5,417,203 A	5/1995	Tovey et al.
5,339,799 A	8/1994	Kami et al.	5,417,361 A	5/1995	Williamson, IV
5,341,724 A	8/1994	Vatel	5,421,829 A	6/1995	Olichney et al.
5,341,810 A	8/1994	Dardel	5,422,567 A	6/1995	Matsunaga
5,342,381 A	8/1994	Tidemand	5,423,471 A	6/1995	Mastri et al.
5,342,395 A	8/1994	Jarrett et al.	5,423,809 A	6/1995	Klicek
5,342,396 A	8/1994	Cook	5,425,745 A	6/1995	Green et al.
5,344,060 A	9/1994	Gravener et al.	5,431,322 A	7/1995	Green et al.
5,344,454 A	9/1994	Clarke et al.	5,431,654 A	7/1995	Nic
5,346,504 A	9/1994	Ortiz et al.	5,431,668 A	7/1995	Burbank, III et al.
5,348,259 A	9/1994	Blanco et al.	5,433,721 A	7/1995	Hooven et al.
5,350,388 A	9/1994	Epstein	5,437,681 A	8/1995	Meade et al.
5,350,391 A	9/1994	Iacovelli	5,438,302 A	8/1995	Goble
5,350,400 A	9/1994	Esposito et al.	5,439,155 A	8/1995	Viola
5,352,229 A	10/1994	Goble et al.	5,439,156 A	8/1995	Grant et al.
5,352,235 A	10/1994	Koros et al.	5,439,479 A	8/1995	Shichman et al.
5,352,238 A	10/1994	Green et al.	5,441,191 A	8/1995	Linden
5,354,303 A	10/1994	Spaeth et al.	5,441,193 A	8/1995	Gravener
5,356,006 A	10/1994	Alpern et al.	5,441,483 A	8/1995	Avitall
5,358,506 A	10/1994	Green et al.	5,441,494 A	8/1995	Ortiz
5,358,510 A	10/1994	Luscombe et al.	5,444,113 A	8/1995	Sinclair et al.
5,359,231 A	10/1994	Flowers et al.	5,445,155 A	8/1995	Sieben
D352,780 S	11/1994	Glaeser et al.	5,445,304 A	8/1995	Plyley et al.
			5,445,644 A	8/1995	Pietrafitta et al.
			5,447,417 A	9/1995	Kuhl et al.
			5,447,513 A	9/1995	Davison et al.
			5,449,355 A	9/1995	Rhum et al.

(56)

References Cited

U.S. PATENT DOCUMENTS

5,449,365 A	9/1995	Green et al.	5,535,937 A	7/1996	Boiarski et al.
5,449,370 A	9/1995	Vaitekunas	5,540,375 A	7/1996	Bolanos et al.
5,452,836 A	9/1995	Huitema et al.	5,541,376 A	7/1996	Ladtkow et al.
5,452,837 A	9/1995	Williamson, IV et al.	5,542,594 A	8/1996	McKean et al.
5,454,378 A	10/1995	Palmer et al.	5,542,949 A	8/1996	Yoon
5,454,822 A	10/1995	Schob et al.	5,543,119 A	8/1996	Sutter et al.
5,454,827 A	10/1995	Aust et al.	5,547,117 A	8/1996	Hamblin et al.
5,456,401 A	10/1995	Green et al.	5,549,621 A	8/1996	Bessler et al.
5,458,579 A	10/1995	Chodorow et al.	5,549,627 A	8/1996	Kieturakis
5,462,215 A	10/1995	Viola et al.	5,549,628 A	8/1996	Cooper et al.
5,464,013 A	11/1995	Lemelson	5,549,637 A	8/1996	Crainich
5,464,144 A	11/1995	Guy et al.	5,551,622 A	9/1996	Yoon
5,464,300 A	11/1995	Crainich	5,553,675 A	9/1996	Pitzen et al.
5,465,894 A	11/1995	Clark et al.	5,553,765 A	9/1996	Knodel et al.
5,465,895 A	11/1995	Knodel et al.	5,554,148 A	9/1996	Aebischer et al.
5,465,896 A	11/1995	Allen et al.	5,554,169 A	9/1996	Green et al.
5,466,020 A	11/1995	Page et al.	5,556,416 A	9/1996	Clark et al.
5,467,911 A	11/1995	Tsuruta et al.	5,558,665 A	9/1996	Kieturakis
5,468,253 A	11/1995	Bezwada et al.	5,558,671 A	9/1996	Yates
5,470,006 A	11/1995	Rodak	5,560,530 A	10/1996	Bolanos et al.
5,470,007 A	11/1995	Plyley et al.	5,560,532 A	10/1996	DeFonzo et al.
5,470,009 A	11/1995	Rodak	5,562,239 A	10/1996	Boiarski et al.
5,470,010 A	11/1995	Rothfuss et al.	5,562,241 A	10/1996	Knodel et al.
5,472,132 A	12/1995	Savage et al.	5,562,682 A	10/1996	Oberlin et al.
5,472,442 A	12/1995	Kliccek	5,562,690 A	10/1996	Green et al.
5,473,204 A	12/1995	Temple	5,562,701 A	10/1996	Huitema et al.
5,474,057 A	12/1995	Makower et al.	5,562,702 A	10/1996	Huitema et al.
5,474,223 A	12/1995	Viola et al.	5,564,615 A	10/1996	Bishop et al.
5,474,566 A	12/1995	Alesi et al.	5,569,161 A	10/1996	Ebling et al.
5,476,206 A	12/1995	Green et al.	5,569,270 A	10/1996	Weng
5,476,479 A	12/1995	Green et al.	5,569,284 A	10/1996	Young et al.
5,478,003 A	12/1995	Green et al.	5,571,090 A	11/1996	Sherts
5,478,354 A	12/1995	Tovey et al.	5,571,100 A	11/1996	Goble et al.
5,480,089 A	1/1996	Blewett	5,571,116 A	11/1996	Bolanos et al.
5,480,409 A	1/1996	Riza	5,571,285 A	11/1996	Chow et al.
5,482,197 A	1/1996	Green et al.	5,573,543 A	11/1996	Akopov et al.
5,484,095 A	1/1996	Green et al.	5,574,431 A	11/1996	McKeown et al.
5,484,398 A	1/1996	Stoddard	5,575,054 A	11/1996	Klinzing et al.
5,484,451 A	1/1996	Akopov et al.	5,575,789 A	11/1996	Bell et al.
5,485,947 A	1/1996	Olson et al.	5,575,799 A	11/1996	Bolanos et al.
5,485,952 A	1/1996	Fontayne	5,575,803 A	11/1996	Cooper et al.
5,487,499 A	1/1996	Sorrentino et al.	5,575,805 A	11/1996	Li
5,487,500 A	1/1996	Knodel et al.	5,577,654 A	11/1996	Bishop
5,489,058 A	2/1996	Plyley et al.	5,579,978 A	12/1996	Green et al.
5,489,256 A	2/1996	Adair	5,580,067 A	12/1996	Hamblin et al.
5,496,312 A	3/1996	Kliccek	5,582,611 A	12/1996	Tsuruta et al.
5,496,317 A	3/1996	Goble et al.	5,582,617 A	12/1996	Klieman et al.
5,497,933 A	3/1996	DeFonzo et al.	5,584,425 A	12/1996	Savage et al.
5,501,654 A	3/1996	Failla et al.	5,586,711 A	12/1996	Plyley et al.
5,503,320 A	4/1996	Webster et al.	5,588,579 A	12/1996	Schnut et al.
5,503,635 A	4/1996	Sauer et al.	5,588,580 A	12/1996	Paul et al.
5,503,638 A	4/1996	Cooper et al.	5,588,581 A	12/1996	Conlon et al.
5,505,363 A	4/1996	Green et al.	5,591,170 A	1/1997	Spievack et al.
5,507,426 A	4/1996	Young et al.	5,591,187 A	1/1997	Dekel
5,509,596 A	4/1996	Green et al.	5,597,107 A	1/1997	Knodel et al.
5,509,916 A	4/1996	Taylor	5,599,151 A	2/1997	Daum et al.
5,511,564 A	4/1996	Wilk	5,599,279 A	2/1997	Slotman et al.
5,514,129 A	5/1996	Smith	5,599,344 A	2/1997	Paterson
5,514,157 A	5/1996	Nicholas et al.	5,599,350 A	2/1997	Schulze et al.
5,518,163 A	5/1996	Hooven	5,599,852 A	2/1997	Scopelianos et al.
5,518,164 A	5/1996	Hooven	5,601,224 A	2/1997	Bishop et al.
5,520,678 A	5/1996	Heckele et al.	5,603,443 A	2/1997	Clark et al.
5,520,700 A	5/1996	Beyar et al.	5,605,272 A	2/1997	Witt et al.
5,522,817 A	6/1996	Sander et al.	5,605,273 A	2/1997	Hamblin et al.
5,522,831 A	6/1996	Sleister et al.	5,607,094 A	3/1997	Clark et al.
5,527,320 A	6/1996	Carruthers et al.	5,607,095 A	3/1997	Smith et al.
5,529,235 A	6/1996	Boiarski et al.	5,607,433 A	3/1997	Polla et al.
D372,086 S	7/1996	Grasso et al.	5,607,450 A	3/1997	Zvenyatsky et al.
5,531,305 A	7/1996	Roberts et al.	5,609,285 A	3/1997	Grant et al.
5,531,744 A	7/1996	Nardella et al.	5,609,601 A	3/1997	Kolesa et al.
5,533,521 A	7/1996	Granger	5,611,709 A	3/1997	McAnulty
5,533,581 A	7/1996	Barth et al.	5,613,966 A	3/1997	Makower et al.
5,533,661 A	7/1996	Main et al.	5,615,820 A	4/1997	Viola
5,535,934 A	7/1996	Boiarski et al.	5,618,294 A	4/1997	Aust et al.
5,535,935 A	7/1996	Vidal et al.	5,618,303 A	4/1997	Marlow et al.
			5,618,307 A	4/1997	Donlon et al.
			5,619,992 A	4/1997	Guthrie et al.
			5,620,289 A	4/1997	Curry
			5,620,452 A	4/1997	Yoon

(56)

References Cited

U.S. PATENT DOCUMENTS

5,624,398 A	4/1997	Smith et al.	5,704,087 A	1/1998	Strub
5,624,452 A	4/1997	Yates	5,704,534 A	1/1998	Huitema et al.
5,626,587 A	5/1997	Bishop et al.	5,706,997 A	1/1998	Green et al.
5,626,595 A	5/1997	Sklar et al.	5,706,998 A	1/1998	Plyley et al.
5,628,446 A	5/1997	Geiste et al.	5,707,392 A	1/1998	Kortenbach
5,628,743 A	5/1997	Cimino	5,709,334 A	1/1998	Sorrentino et al.
5,628,745 A	5/1997	Bek	5,709,335 A	1/1998	Heck
5,630,539 A	5/1997	Plyley et al.	5,709,680 A	1/1998	Yates et al.
5,630,540 A	5/1997	Blewett	5,709,706 A	1/1998	Kienzle et al.
5,630,541 A	5/1997	Williamson, IV et al.	5,711,472 A	1/1998	Bryan
5,630,782 A	5/1997	Adair	5,713,128 A	2/1998	Schrenk et al.
5,632,432 A	5/1997	Schulze et al.	5,713,505 A	2/1998	Huitema
5,632,433 A	5/1997	Grant et al.	5,713,895 A	2/1998	Lontine et al.
5,634,584 A	6/1997	Okorochoa et al.	5,713,896 A	2/1998	Nardella
5,636,779 A	6/1997	Palmer	5,713,920 A	2/1998	Bezwada et al.
5,636,780 A	6/1997	Green et al.	5,715,987 A	2/1998	Kelley et al.
5,639,008 A	6/1997	Gallagher et al.	5,715,988 A	2/1998	Palmer
D381,077 S	7/1997	Hunt	5,716,366 A	2/1998	Yates
5,643,291 A	7/1997	Pier et al.	5,718,359 A	2/1998	Palmer et al.
5,645,209 A	7/1997	Green et al.	5,718,360 A	2/1998	Green et al.
5,647,526 A	7/1997	Green et al.	5,718,548 A	2/1998	Cotellessa
5,647,869 A	7/1997	Goble et al.	5,720,744 A	2/1998	Eggleston et al.
5,649,937 A	7/1997	Bito et al.	D393,067 S	3/1998	Geary et al.
5,649,956 A	7/1997	Jensen et al.	5,725,536 A	3/1998	Oberlin et al.
5,651,491 A	7/1997	Heaton et al.	5,725,554 A	3/1998	Simon et al.
5,653,373 A	8/1997	Green et al.	5,728,110 A	3/1998	Vidal et al.
5,653,374 A	8/1997	Young et al.	5,728,121 A	3/1998	Bimbo et al.
5,653,677 A	8/1997	Okada et al.	5,730,758 A	3/1998	Allgeyer
5,653,721 A	8/1997	Knodel et al.	5,732,821 A	3/1998	Stone et al.
5,655,698 A	8/1997	Yoon	5,732,871 A	3/1998	Clark et al.
5,657,921 A	8/1997	Young et al.	5,732,872 A	3/1998	Bolduc et al.
5,658,238 A	8/1997	Suzuki et al.	5,733,308 A	3/1998	Daugherty et al.
5,658,281 A	8/1997	Heard	5,735,445 A	4/1998	Vidal et al.
5,658,300 A	8/1997	Bito et al.	5,735,848 A	4/1998	Yates et al.
5,658,307 A	8/1997	Exconde	5,735,874 A	4/1998	Measamer et al.
5,662,258 A	9/1997	Knodel et al.	5,738,474 A	4/1998	Blewett
5,662,260 A	9/1997	Yoon	5,738,648 A	4/1998	Lands et al.
5,662,662 A	9/1997	Bishop et al.	5,743,456 A	4/1998	Jones et al.
5,665,085 A	9/1997	Nardella	5,747,953 A	5/1998	Philipp
5,667,517 A	9/1997	Hooven	5,749,889 A	5/1998	Bacich et al.
5,667,526 A	9/1997	Levin	5,749,893 A	5/1998	Vidal et al.
5,667,527 A	9/1997	Cook	5,752,644 A	5/1998	Bolanos et al.
5,669,544 A	9/1997	Schulze et al.	5,752,965 A	5/1998	Francis et al.
5,669,904 A	9/1997	Platt, Jr. et al.	5,755,717 A	5/1998	Yates et al.
5,669,907 A	9/1997	Platt, Jr. et al.	5,758,814 A	6/1998	Gallagher et al.
5,669,918 A	9/1997	Balazs et al.	5,762,255 A	6/1998	Chrisman et al.
5,673,840 A	10/1997	Schulze et al.	5,762,256 A	6/1998	Mastri et al.
5,673,841 A	10/1997	Schulze et al.	5,766,188 A	6/1998	Igaki
5,673,842 A	10/1997	Bittner et al.	5,766,205 A	6/1998	Zvenyatsky et al.
5,674,286 A	10/1997	D'Alessio et al.	5,769,892 A	6/1998	Kingwell
5,678,748 A	10/1997	Plyley et al.	5,772,379 A	6/1998	Evensen
5,680,981 A	10/1997	Mililli et al.	5,772,578 A	6/1998	Heimberger et al.
5,680,982 A	10/1997	Schulze et al.	5,772,659 A	6/1998	Becker et al.
5,680,983 A	10/1997	Plyley et al.	5,776,130 A	7/1998	Buysse et al.
5,683,349 A	11/1997	Makower et al.	5,778,939 A	7/1998	Hok-Yin
5,685,474 A	11/1997	Seeber	5,779,130 A	7/1998	Alesi et al.
5,686,090 A	11/1997	Schilder et al.	5,779,131 A	7/1998	Knodel et al.
5,688,270 A	11/1997	Yates et al.	5,779,132 A	7/1998	Knodel et al.
5,690,269 A	11/1997	Bolanos et al.	5,782,396 A	7/1998	Mastri et al.
5,692,668 A	12/1997	Schulze et al.	5,782,397 A	7/1998	Koukline
5,693,020 A	12/1997	Rauh	5,782,749 A	7/1998	Riza
5,693,042 A	12/1997	Boiarski et al.	5,782,859 A	7/1998	Nicholas et al.
5,693,051 A	12/1997	Schulze et al.	5,784,934 A	7/1998	Izumisawa
5,695,494 A	12/1997	Becker	5,785,232 A	7/1998	Vidal et al.
5,695,502 A	12/1997	Pier et al.	5,785,647 A	7/1998	Tompkins et al.
5,695,504 A	12/1997	Gifford, III et al.	5,787,897 A	8/1998	Kieturakis
5,695,524 A	12/1997	Kelley et al.	5,792,135 A	8/1998	Madhani et al.
5,697,542 A	12/1997	Knodel et al.	5,792,165 A	8/1998	Klieman et al.
5,697,543 A	12/1997	Burdorff	5,794,834 A	8/1998	Hamblin et al.
5,697,909 A	12/1997	Eggers et al.	5,796,188 A	8/1998	Bays
5,697,943 A	12/1997	Sauer et al.	5,797,536 A	8/1998	Smith et al.
5,700,270 A	12/1997	Peysen et al.	5,797,537 A	8/1998	Oberlin et al.
5,702,387 A	12/1997	Arts et al.	5,797,538 A	8/1998	Heaton et al.
5,702,408 A	12/1997	Wales et al.	5,797,906 A	8/1998	Rhum et al.
5,702,409 A	12/1997	Rayburn et al.	5,797,959 A	8/1998	Castro et al.
			5,799,857 A	9/1998	Robertson et al.
			5,800,379 A	9/1998	Edwards
			5,800,423 A	9/1998	Jensen
			5,806,676 A	9/1998	Wasgien

(56)

References Cited

U.S. PATENT DOCUMENTS

5,807,376 A	9/1998	Viola et al.	5,937,951 A	8/1999	Izuchukwu et al.
5,807,378 A	9/1998	Jensen et al.	5,938,667 A	8/1999	Peyser et al.
5,807,393 A	9/1998	Williamson, IV et al.	5,941,442 A	8/1999	Geiste et al.
5,809,441 A	9/1998	McKee	5,941,890 A	8/1999	Voegele et al.
5,810,721 A	9/1998	Mueller et al.	5,944,172 A	8/1999	Hannula
5,810,811 A	9/1998	Yates et al.	5,944,715 A	8/1999	Goble et al.
5,810,846 A	9/1998	Virnich et al.	5,947,984 A	9/1999	Whipple
5,810,855 A	9/1998	Rayburn et al.	5,948,030 A	9/1999	Miller et al.
5,813,813 A	9/1998	Daum et al.	5,951,516 A	9/1999	Bunyan
5,814,055 A	9/1998	Knodel et al.	5,951,552 A	9/1999	Long et al.
5,814,057 A	9/1998	Oi et al.	5,951,574 A	9/1999	Stefanchik et al.
5,816,471 A	10/1998	Plyley et al.	5,951,581 A	9/1999	Saadat et al.
5,817,084 A	10/1998	Jensen	5,954,259 A	9/1999	Viola et al.
5,817,091 A	10/1998	Nardella et al.	5,964,394 A	10/1999	Robertson
5,817,093 A	10/1998	Williamson, IV et al.	5,964,774 A	10/1999	McKean et al.
5,817,109 A	10/1998	McGarry et al.	5,971,916 A	10/1999	Koren
5,817,119 A	10/1998	Klieman et al.	5,973,221 A	10/1999	Collyer et al.
5,820,009 A	10/1998	Melling et al.	D416,089 S	11/1999	Barton et al.
5,823,066 A	10/1998	Huitema et al.	5,984,949 A	11/1999	Levin
5,826,776 A	10/1998	Schulze et al.	5,988,479 A	11/1999	Palmer
5,827,271 A	10/1998	Buysse et al.	5,997,528 A	12/1999	Bisch et al.
5,827,298 A	10/1998	Hart et al.	5,997,552 A	12/1999	Person et al.
5,829,662 A	11/1998	Allen et al.	6,003,517 A	12/1999	Sheffield et al.
5,833,690 A	11/1998	Yates et al.	6,004,319 A	12/1999	Goble et al.
5,833,695 A	11/1998	Yoon	6,004,335 A	12/1999	Vaitekunas et al.
5,833,696 A	11/1998	Whitfield et al.	6,010,054 A	1/2000	Johnson et al.
5,836,503 A	11/1998	Ehrenfels et al.	6,010,513 A	1/2000	Tormala et al.
5,836,960 A	11/1998	Kolesa et al.	6,012,494 A	1/2000	Balazs
5,839,639 A	11/1998	Sauer et al.	6,013,076 A	1/2000	Goble et al.
5,843,021 A	12/1998	Edwards et al.	6,015,406 A	1/2000	Goble et al.
5,843,096 A	12/1998	Igaki et al.	6,015,417 A	1/2000	Reynolds, Jr.
5,843,097 A	12/1998	Mayenberger et al.	6,017,322 A	1/2000	Snoke et al.
5,843,122 A	12/1998	Riza	6,017,354 A	1/2000	Culp et al.
5,843,132 A	12/1998	Ilvento	6,017,356 A	1/2000	Frederick et al.
5,843,169 A	12/1998	Taheri	6,022,352 A	2/2000	Vandewalle
5,846,254 A	12/1998	Schulze et al.	6,024,741 A	2/2000	Williamson, IV et al.
5,849,011 A	12/1998	Jones et al.	6,024,748 A	2/2000	Manzo et al.
5,849,023 A	12/1998	Mericle	6,027,501 A	2/2000	Goble et al.
5,855,311 A	1/1999	Hamblin et al.	6,032,849 A	3/2000	Mastri et al.
5,855,583 A	1/1999	Wang et al.	6,033,378 A	3/2000	Lundquist et al.
5,860,581 A	1/1999	Robertson et al.	6,033,399 A	3/2000	Gines
5,860,975 A	1/1999	Goble et al.	6,033,427 A	3/2000	Lee
5,865,361 A	2/1999	Milliman et al.	6,037,724 A	3/2000	Buss et al.
5,868,760 A	2/1999	McGuckin, Jr.	6,039,733 A	3/2000	Buysse et al.
5,871,135 A	2/1999	Williamson, IV et al.	6,039,734 A	3/2000	Goble
5,873,885 A	2/1999	Weidenbenner	6,042,601 A	3/2000	Smith
5,876,401 A	3/1999	Schulze et al.	6,045,560 A	4/2000	McKean et al.
5,878,193 A	3/1999	Wang et al.	6,047,861 A	4/2000	Vidal et al.
5,878,937 A	3/1999	Green et al.	6,050,472 A	4/2000	Shibata
5,878,938 A	3/1999	Bittner et al.	6,050,990 A	4/2000	Tankovich et al.
5,891,160 A	4/1999	Williamson, IV et al.	6,050,996 A	4/2000	Schmaltz et al.
5,893,506 A	4/1999	Powell	6,053,390 A	4/2000	Green et al.
5,893,835 A	4/1999	Witt et al.	6,053,922 A	4/2000	Krause et al.
5,893,878 A	4/1999	Pierce	RE36,720 E	5/2000	Green et al.
5,894,979 A	4/1999	Powell	6,056,735 A	5/2000	Okada et al.
5,897,552 A	4/1999	Edwards et al.	6,056,746 A	5/2000	Goble et al.
5,897,562 A	4/1999	Bolanos et al.	6,062,360 A	5/2000	Shields
5,899,914 A	5/1999	Zirps et al.	6,063,097 A	5/2000	Oi et al.
5,901,895 A	5/1999	Heaton et al.	6,063,098 A	5/2000	Houser et al.
5,902,312 A	5/1999	Frater et al.	6,065,919 A	5/2000	Peck
5,904,647 A	5/1999	Ouchi	6,066,132 A	5/2000	Chen et al.
5,904,693 A	5/1999	Dicesare et al.	6,068,627 A	5/2000	Orszulak et al.
5,904,702 A	5/1999	Ek et al.	6,071,233 A	6/2000	Ishikawa et al.
5,906,625 A	5/1999	Bito et al.	6,074,386 A	6/2000	Goble et al.
5,908,402 A	6/1999	Blythe	6,074,401 A	6/2000	Gardiner et al.
5,908,427 A	6/1999	McKean et al.	6,077,286 A	6/2000	Cuschieri et al.
5,911,353 A	6/1999	Bolanos et al.	6,079,606 A	6/2000	Milliman et al.
5,915,616 A	6/1999	Viola et al.	6,080,181 A	6/2000	Jensen et al.
5,916,225 A	6/1999	Kugel	6,082,577 A	7/2000	Coates et al.
5,918,791 A	7/1999	Sorrentino et al.	6,083,191 A	7/2000	Rose
5,919,198 A	7/1999	Graves, Jr. et al.	6,083,234 A	7/2000	Nicholas et al.
5,921,956 A	7/1999	Grinberg et al.	6,083,242 A	7/2000	Cook
5,928,256 A	7/1999	Riza	6,086,544 A	7/2000	Hibner et al.
5,931,847 A	8/1999	Bittner et al.	6,086,600 A	7/2000	Kortenbach
5,931,853 A	8/1999	McEwen et al.	6,090,106 A	7/2000	Goble et al.
			6,093,186 A	7/2000	Goble
			6,099,537 A	8/2000	Sugai et al.
			6,099,551 A	8/2000	Gabbay
			6,102,271 A	8/2000	Longo et al.

(56)

References Cited

U.S. PATENT DOCUMENTS

6,109,500	A	8/2000	Alli et al.	6,306,134	B1	10/2001	Goble et al.
6,117,148	A	9/2000	Ravo et al.	6,306,149	B1	10/2001	Meade
6,117,158	A	9/2000	Measamer et al.	6,309,403	B1	10/2001	Minor et al.
6,119,913	A	9/2000	Adams et al.	6,315,184	B1	11/2001	Whitman
6,120,433	A	9/2000	Mizuno et al.	6,320,123	B1	11/2001	Reimers
6,123,241	A	9/2000	Walter et al.	6,322,494	B1	11/2001	Bullivant et al.
H1904	H	10/2000	Yates et al.	6,324,339	B1	11/2001	Hudson et al.
6,126,058	A	10/2000	Adams et al.	6,325,799	B1	12/2001	Goble
6,126,670	A	10/2000	Walker et al.	6,325,810	B1	12/2001	Hamilton et al.
6,131,789	A	10/2000	Schulze et al.	6,330,965	B1	12/2001	Milliman et al.
6,131,790	A	10/2000	Piraka	6,331,181	B1	12/2001	Tierney et al.
6,132,368	A	10/2000	Cooper	6,331,761	B1	12/2001	Kumar et al.
6,139,546	A	10/2000	Koenig et al.	6,333,029	B1	12/2001	Vyakarnam et al.
6,149,660	A	11/2000	Lauffer et al.	6,334,860	B1	1/2002	Dorn
6,152,935	A	11/2000	Kammerer et al.	6,334,861	B1	1/2002	Chandler et al.
6,155,473	A	12/2000	Tompkins et al.	6,336,926	B1	1/2002	Goble
6,156,056	A	12/2000	Kearns et al.	6,338,737	B1	1/2002	Toledano
6,159,146	A	12/2000	El Gazayerli	6,343,731	B1	2/2002	Adams et al.
6,159,200	A	12/2000	Verdura et al.	6,346,077	B1	2/2002	Taylor et al.
6,159,224	A	12/2000	Yoon	6,348,061	B1	2/2002	Whitman
6,162,208	A	12/2000	Hipps	6,352,503	B1	3/2002	Matsui et al.
6,165,175	A	12/2000	Wampler et al.	6,352,532	B1	3/2002	Kramer et al.
6,165,184	A	12/2000	Verdura et al.	6,355,699	B1	3/2002	Vyakarnam et al.
6,165,188	A	12/2000	Saadat et al.	6,356,072	B1	3/2002	Chass
6,168,605	B1	1/2001	Measamer et al.	6,358,224	B1	3/2002	Tims et al.
6,171,305	B1	1/2001	Sherman	6,364,877	B1	4/2002	Goble et al.
6,171,316	B1	1/2001	Kovac et al.	6,364,888	B1	4/2002	Niemeyer et al.
6,171,330	B1	1/2001	Benchetrit	6,370,981	B2	4/2002	Watarai
6,174,308	B1	1/2001	Goble et al.	6,373,152	B1	4/2002	Wang et al.
6,174,309	B1	1/2001	Wrublewski et al.	6,383,201	B1	5/2002	Dong
6,179,194	B1	1/2001	Morton	6,387,113	B1	5/2002	Hawkins et al.
6,179,195	B1	1/2001	Adams et al.	6,387,114	B2	5/2002	Adams
6,179,776	B1	1/2001	Adams et al.	6,391,038	B2	5/2002	Vargas et al.
6,179,849	B1	1/2001	Yencho et al.	6,398,781	B1	6/2002	Goble et al.
6,181,105	B1	1/2001	Cutolo et al.	6,398,797	B2	6/2002	Bombard et al.
6,182,673	B1	2/2001	Kindermann et al.	6,402,766	B2	6/2002	Bowman et al.
6,187,003	B1	2/2001	Buysse et al.	6,406,440	B1	6/2002	Stefanchik
6,190,386	B1	2/2001	Rydell	6,406,472	B1	6/2002	Jensen
6,193,129	B1	2/2001	Bittner et al.	6,409,724	B1	6/2002	Penny et al.
6,197,042	B1	3/2001	Ginn et al.	H2037	H	7/2002	Yates et al.
6,200,330	B1	3/2001	Benderev et al.	6,413,274	B1	7/2002	Pedros
6,202,914	B1	3/2001	Geiste et al.	6,416,486	B1	7/2002	Wampler
6,206,897	B1	3/2001	Jamiolkowski et al.	6,416,509	B1	7/2002	Goble et al.
6,206,904	B1	3/2001	Ouchi	6,419,695	B1	7/2002	Gabbay
6,210,403	B1	4/2001	Kliccek	6,423,079	B1	7/2002	Blake, III
6,213,999	B1	4/2001	Platt, Jr. et al.	RE37,814	E	8/2002	Allgeyer
6,214,028	B1	4/2001	Yoon et al.	6,428,070	B1	8/2002	Takanashi et al.
6,220,368	B1	4/2001	Ark et al.	6,429,611	B1	8/2002	Li
6,223,100	B1	4/2001	Green	6,436,097	B1	8/2002	Nardella
6,223,835	B1	5/2001	Habedank et al.	6,436,107	B1	8/2002	Wang et al.
6,224,617	B1	5/2001	Saadat et al.	6,436,110	B2	8/2002	Bowman et al.
6,228,081	B1	5/2001	Goble	6,436,122	B1	8/2002	Frank et al.
6,228,083	B1	5/2001	Lands et al.	6,439,439	B1	8/2002	Rickard et al.
6,228,084	B1	5/2001	Kirwan, Jr.	6,439,446	B1	8/2002	Perry et al.
6,231,565	B1	5/2001	Tovey et al.	6,440,146	B2	8/2002	Nicholas et al.
6,234,178	B1	5/2001	Goble et al.	6,443,973	B1	9/2002	Whitman
6,241,139	B1	6/2001	Milliman et al.	6,447,518	B1	9/2002	Krause et al.
6,241,140	B1	6/2001	Adams et al.	6,447,864	B2	9/2002	Johnson et al.
6,241,723	B1	6/2001	Heim et al.	6,450,391	B1	9/2002	Kayan et al.
6,245,084	B1	6/2001	Mark et al.	6,450,989	B2	9/2002	Dubrul et al.
6,248,117	B1	6/2001	Blatter	6,454,781	B1	9/2002	Witt et al.
6,249,076	B1	6/2001	Madden et al.	6,468,275	B1	10/2002	Wampler et al.
6,250,532	B1	6/2001	Green et al.	6,471,106	B1	10/2002	Reining
6,258,107	B1	7/2001	Balazs et al.	6,478,210	B2	11/2002	Adams et al.
6,261,286	B1	7/2001	Goble et al.	6,482,200	B2	11/2002	Shippert
6,264,086	B1	7/2001	McGuckin, Jr.	6,485,490	B2	11/2002	Wampler et al.
6,264,087	B1	7/2001	Whitman	6,485,503	B2	11/2002	Jacobs et al.
6,270,508	B1	8/2001	Klieman et al.	6,485,667	B1	11/2002	Tan
6,273,876	B1	8/2001	Klima et al.	6,488,196	B1	12/2002	Fenton, Jr.
6,273,897	B1	8/2001	Dalessandro et al.	6,488,197	B1	12/2002	Whitman
6,277,114	B1	8/2001	Bullivant et al.	6,491,201	B1	12/2002	Whitman
6,293,942	B1	9/2001	Goble et al.	6,491,690	B1	12/2002	Goble et al.
6,296,640	B1	10/2001	Wampler et al.	6,491,701	B2	12/2002	Tierney et al.
6,302,311	B1	10/2001	Adams et al.	6,492,785	B1	12/2002	Kasten et al.
6,305,891	B1	10/2001	Burlingame	6,494,896	B1	12/2002	D'Alessio et al.
				6,500,176	B1	12/2002	Truckai et al.
				6,500,194	B2	12/2002	Benderev et al.
				6,503,257	B2	1/2003	Grant et al.
				6,503,259	B2	1/2003	Huxel et al.

(56)

References Cited

U.S. PATENT DOCUMENTS

6,505,768 B2	1/2003	Whitman	6,669,073 B2	12/2003	Milliman et al.
6,510,854 B2	1/2003	Goble	6,671,185 B2	12/2003	Duval
6,511,468 B1	1/2003	Cragg et al.	D484,977 S	1/2004	Ryan et al.
6,512,360 B1	1/2003	Goto et al.	6,676,660 B2	1/2004	Wampler et al.
6,517,528 B1	2/2003	Pantages et al.	6,679,269 B2	1/2004	Swanson
6,517,535 B2	2/2003	Edwards	6,679,410 B2	1/2004	Wursch et al.
6,517,565 B1	2/2003	Whitman et al.	6,681,978 B2	1/2004	Geiste et al.
6,517,566 B1	2/2003	Hovland et al.	6,681,979 B2	1/2004	Whitman
6,522,101 B2	2/2003	Malackowski	6,682,527 B2	1/2004	Strul
6,527,782 B2	3/2003	Hogg et al.	6,682,528 B2	1/2004	Frazier et al.
6,527,785 B2	3/2003	Sancoff et al.	6,685,727 B2	2/2004	Fisher et al.
6,533,157 B1	3/2003	Whitman	6,689,153 B1	2/2004	Skiba
6,533,784 B2	3/2003	Truckai et al.	6,692,507 B2	2/2004	Pugsley et al.
6,535,764 B2	3/2003	Imran et al.	6,695,198 B2	2/2004	Adams et al.
6,543,456 B1	4/2003	Freeman	6,695,199 B2	2/2004	Whitman
6,545,384 B1	4/2003	Pelrine et al.	6,698,643 B2	3/2004	Whitman
6,547,786 B1	4/2003	Goble	6,699,235 B2	3/2004	Wallace et al.
6,550,546 B2	4/2003	Thurler et al.	6,704,210 B1	3/2004	Myers
6,551,333 B2	4/2003	Kuhns et al.	6,705,503 B1	3/2004	Pedicini et al.
6,554,861 B2	4/2003	Knox et al.	6,709,445 B2	3/2004	Boebel et al.
6,555,770 B2	4/2003	Kawase	6,712,773 B1	3/2004	Viola
6,558,378 B2	5/2003	Sherman et al.	6,716,223 B2	4/2004	Leopold et al.
6,558,379 B1	5/2003	Batchelor et al.	6,716,232 B1	4/2004	Vidal et al.
6,565,560 B1	5/2003	Goble et al.	6,716,233 B1	4/2004	Whitman
6,569,085 B2	5/2003	Kortenbach et al.	6,722,552 B2	4/2004	Fenton, Jr.
6,569,171 B2	5/2003	DeGuillebon et al.	6,723,087 B2	4/2004	O'Neill et al.
6,578,751 B2	6/2003	Hartwick	6,723,091 B2	4/2004	Goble et al.
6,582,427 B1	6/2003	Goble et al.	6,726,697 B2	4/2004	Nicholas et al.
6,582,441 B1	6/2003	He et al.	6,729,119 B2	5/2004	Schnipke et al.
6,583,533 B2	6/2003	Pelrine et al.	6,736,825 B2	5/2004	Blatter et al.
6,585,144 B2	7/2003	Adams et al.	6,736,854 B2	5/2004	Vadurro et al.
6,588,643 B2	7/2003	Bolduc et al.	6,740,030 B2	5/2004	Martone et al.
6,589,164 B1	7/2003	Flaherty	6,747,121 B2	6/2004	Gogolewski
6,592,538 B1	7/2003	Hotchkiss et al.	6,749,560 B1	6/2004	Konstorum et al.
6,592,597 B2	7/2003	Grant et al.	6,752,768 B2	6/2004	Burdorff et al.
6,596,296 B1	7/2003	Nelson et al.	6,752,816 B2	6/2004	Culp et al.
6,596,304 B1	7/2003	Bayon et al.	6,755,195 B1	6/2004	Lemke et al.
6,596,432 B2	7/2003	Kawakami et al.	6,755,338 B2	6/2004	Hahnen et al.
D478,665 S	8/2003	Isaacs et al.	6,758,846 B2	7/2004	Goble et al.
D478,986 S	8/2003	Johnston et al.	6,761,685 B2	7/2004	Adams et al.
6,601,749 B2	8/2003	Sullivan et al.	6,762,339 B1	7/2004	Klun et al.
6,602,252 B2	8/2003	Mollenauer	6,767,352 B2	7/2004	Field et al.
6,602,262 B2	8/2003	Griego et al.	6,767,356 B2	7/2004	Kanner et al.
6,605,078 B2	8/2003	Adams	6,769,590 B2	8/2004	Vresh et al.
6,605,669 B2	8/2003	Awokola et al.	6,769,594 B2	8/2004	Orban, III
6,607,475 B2	8/2003	Doyle et al.	6,770,027 B2	8/2004	Banik et al.
6,613,069 B2	9/2003	Boyd et al.	6,770,072 B1	8/2004	Truckai et al.
6,616,686 B2	9/2003	Coleman et al.	6,773,409 B2	8/2004	Truckai et al.
6,619,529 B2	9/2003	Green et al.	6,773,438 B1	8/2004	Knodel et al.
6,620,166 B1	9/2003	Wenstrom, Jr. et al.	6,777,838 B2	8/2004	Miekka et al.
6,626,834 B2	9/2003	Dunne et al.	6,780,151 B2	8/2004	Grabover et al.
6,629,630 B2	10/2003	Adams	6,780,180 B1	8/2004	Goble et al.
6,629,974 B2	10/2003	Penny et al.	6,783,524 B2	8/2004	Anderson et al.
6,629,988 B2	10/2003	Weadock	6,786,382 B1	9/2004	Hoffman
6,636,412 B2	10/2003	Smith	6,786,864 B2	9/2004	Matsuura et al.
6,638,108 B2	10/2003	Tachi	6,786,896 B1	9/2004	Madhani et al.
6,638,285 B2	10/2003	Gabbay	6,790,173 B2	9/2004	Saadat et al.
6,638,297 B1	10/2003	Huitema	6,793,652 B1	9/2004	Whitman et al.
RE38,335 E	11/2003	Aust et al.	6,793,661 B2	9/2004	Hamilton et al.
6,641,528 B2	11/2003	Torii	6,793,663 B2	9/2004	Kneifel et al.
6,644,532 B2	11/2003	Green et al.	6,802,843 B2	10/2004	Truckai et al.
6,645,201 B1	11/2003	Utley et al.	6,805,273 B2	10/2004	Bilotti et al.
6,646,307 B1	11/2003	Yu et al.	6,806,808 B1	10/2004	Watters et al.
6,648,816 B2	11/2003	Irion et al.	6,808,525 B2	10/2004	Latterell et al.
6,652,595 B1	11/2003	Nicolo	6,814,741 B2	11/2004	Bowman et al.
D484,243 S	12/2003	Ryan et al.	6,817,508 B1	11/2004	Racenet et al.
D484,595 S	12/2003	Ryan et al.	6,817,509 B2	11/2004	Geiste et al.
D484,596 S	12/2003	Ryan et al.	6,817,974 B2	11/2004	Cooper et al.
6,656,177 B2	12/2003	Truckai et al.	6,818,018 B1	11/2004	Sawhney
6,656,193 B2	12/2003	Grant et al.	6,820,791 B2	11/2004	Adams
6,663,623 B1	12/2003	Oyama et al.	6,821,273 B2	11/2004	Mollenauer
6,663,641 B1	12/2003	Kovac et al.	6,821,282 B2	11/2004	Perry et al.
6,666,854 B1	12/2003	Lange	6,821,284 B2	11/2004	Sturtz et al.
6,666,875 B1	12/2003	Sakurai et al.	6,827,246 B2	12/2004	Sullivan et al.
6,667,825 B2	12/2003	Lu et al.	6,827,712 B2	12/2004	Tovey et al.
			6,827,725 B2	12/2004	Batchelor et al.
			6,828,902 B2	12/2004	Casden
			6,830,174 B2	12/2004	Hillstead et al.
			6,831,629 B2	12/2004	Nishino et al.

(56)

References Cited

U.S. PATENT DOCUMENTS

6,832,998 B2	12/2004	Goble	6,981,941 B2	1/2006	Whitman et al.
6,834,001 B2	12/2004	Myono	6,981,978 B2	1/2006	Gannoe
6,835,173 B2	12/2004	Couvillon, Jr.	6,984,203 B2	1/2006	Tartaglia et al.
6,835,199 B2	12/2004	McGuckin, Jr. et al.	6,984,231 B2	1/2006	Goble et al.
6,835,336 B2	12/2004	Watt	6,986,451 B1	1/2006	Mastri et al.
6,837,846 B2	1/2005	Jaffe et al.	6,988,649 B2	1/2006	Shelton, IV et al.
6,838,493 B2	1/2005	Williams et al.	6,988,650 B2	1/2006	Schwemberger et al.
6,840,423 B2	1/2005	Adams et al.	6,990,731 B2	1/2006	Haytayan
6,843,403 B2	1/2005	Whitman	6,990,796 B2	1/2006	Schnipke et al.
6,843,789 B2	1/2005	Goble	6,994,708 B2	2/2006	Manzo
6,843,793 B2	1/2005	Brock et al.	6,995,729 B2	2/2006	Govari et al.
6,846,307 B2	1/2005	Whitman et al.	6,997,931 B2	2/2006	Sauer et al.
6,846,308 B2	1/2005	Whitman et al.	7,000,818 B2	2/2006	Shelton, IV et al.
6,846,309 B2	1/2005	Whitman et al.	7,000,819 B2	2/2006	Swayze et al.
6,849,071 B2	2/2005	Whitman et al.	7,001,380 B2	2/2006	Goble
6,850,817 B1	2/2005	Green	7,001,408 B2	2/2006	Knodel et al.
6,858,005 B2	2/2005	Ohline et al.	7,008,435 B2	3/2006	Cummins
RE38,708 E	3/2005	Bolanos et al.	7,009,039 B2	3/2006	Yayon et al.
D502,994 S	3/2005	Blake, III	7,011,657 B2	3/2006	Truckai et al.
6,861,142 B1	3/2005	Wilkie et al.	7,018,357 B2	3/2006	Emmons
6,863,668 B2	3/2005	Gillespie et al.	7,018,390 B2	3/2006	Turovskiy et al.
6,863,694 B1	3/2005	Boyce et al.	7,025,743 B2	4/2006	Mann et al.
6,866,178 B2	3/2005	Adams et al.	7,029,435 B2	4/2006	Nakao
6,866,671 B2	3/2005	Tierney et al.	7,032,798 B2	4/2006	Whitman et al.
6,867,248 B1	3/2005	Martin et al.	7,032,799 B2	4/2006	Viola et al.
6,869,435 B2	3/2005	Blake, III	7,033,356 B2	4/2006	Latterell et al.
6,872,214 B2	3/2005	Sonnenschein et al.	7,036,680 B1	5/2006	Flannery
6,874,669 B2	4/2005	Adams et al.	7,037,344 B2	5/2006	Kagan et al.
6,877,647 B2	4/2005	Green et al.	7,041,102 B2	5/2006	Truckai et al.
6,878,106 B1	4/2005	Herrmann	7,041,868 B2	5/2006	Greene et al.
6,889,116 B2	5/2005	Jinno	7,043,852 B2	5/2006	Hayashida et al.
6,893,435 B2	5/2005	Goble	7,044,352 B2	5/2006	Shelton, IV et al.
6,899,538 B2	5/2005	Matoba	7,044,353 B2	5/2006	Mastri et al.
6,905,057 B2	6/2005	Swayze et al.	7,048,687 B1	5/2006	Reuss et al.
6,905,497 B2	6/2005	Truckai et al.	7,048,745 B2	5/2006	Tierney et al.
6,908,472 B2	6/2005	Wiener et al.	7,052,494 B2	5/2006	Goble et al.
6,911,033 B2	6/2005	de Guillebon et al.	7,052,499 B2	5/2006	Steger et al.
6,913,579 B2	7/2005	Truckai et al.	7,055,730 B2	6/2006	Ehrenfels et al.
6,913,608 B2	7/2005	Liddicoat et al.	7,055,731 B2	6/2006	Shelton, IV et al.
6,913,613 B2	7/2005	Schwarz et al.	7,056,284 B2	6/2006	Martone et al.
6,921,397 B2	7/2005	Corcoran et al.	7,056,330 B2	6/2006	Gayton
6,921,412 B1	7/2005	Black et al.	7,059,331 B2	6/2006	Adams et al.
6,923,093 B2	8/2005	Ullah	7,059,508 B2	6/2006	Shelton, IV et al.
6,923,803 B2	8/2005	Goble	7,063,671 B2	6/2006	Couvillon, Jr.
6,926,716 B2	8/2005	Baker et al.	7,063,712 B2	6/2006	Vargas et al.
6,929,641 B2	8/2005	Goble et al.	7,066,879 B2	6/2006	Fowler et al.
6,929,644 B2	8/2005	Truckai et al.	7,066,944 B2	6/2006	Laufer et al.
6,931,830 B2	8/2005	Liao	7,067,038 B2	6/2006	Trokhon et al.
6,932,218 B2	8/2005	Kosann et al.	7,070,083 B2	7/2006	Jankowski
6,932,810 B2	8/2005	Ryan	7,070,559 B2	7/2006	Adams et al.
6,936,042 B2	8/2005	Wallace et al.	7,070,597 B2	7/2006	Truckai et al.
D509,297 S	9/2005	Wells	7,071,287 B2	7/2006	Rhine et al.
D509,589 S	9/2005	Wells	7,075,770 B1	7/2006	Smith
6,939,358 B2	9/2005	Palacios et al.	7,077,856 B2	7/2006	Whitman
6,942,662 B2	9/2005	Goble et al.	7,080,769 B2	7/2006	Vresh et al.
6,942,674 B2	9/2005	Belef et al.	7,081,114 B2	7/2006	Rashidi
6,945,444 B2	9/2005	Gresham et al.	7,083,073 B2	8/2006	Yoshie et al.
6,945,981 B2	9/2005	Donofrio et al.	7,083,075 B2	8/2006	Swayze et al.
6,953,138 B1	10/2005	Dworak et al.	7,083,571 B2	8/2006	Wang et al.
6,953,139 B2	10/2005	Milliman et al.	7,083,615 B2	8/2006	Peterson et al.
6,958,035 B2	10/2005	Friedman et al.	7,083,619 B2	8/2006	Truckai et al.
6,959,851 B2	11/2005	Heinrich	7,083,620 B2	8/2006	Jahns et al.
6,959,852 B2	11/2005	Shelton, IV et al.	7,087,049 B2	8/2006	Nowlin et al.
6,960,107 B1	11/2005	Schaub et al.	7,087,054 B2	8/2006	Truckai et al.
6,960,163 B2	11/2005	Ewers et al.	7,087,071 B2	8/2006	Nicholas et al.
6,960,220 B2	11/2005	Marino et al.	7,090,637 B2	8/2006	Danitz et al.
6,964,363 B2	11/2005	Wales et al.	7,090,673 B2	8/2006	Dycus et al.
6,966,907 B2	11/2005	Goble	7,090,683 B2	8/2006	Brock et al.
6,966,909 B2	11/2005	Marshall et al.	7,090,684 B2	8/2006	McGuckin, Jr. et al.
6,971,988 B2	12/2005	Orban, III	7,094,202 B2	8/2006	Nobis et al.
6,972,199 B2	12/2005	Lebouitz et al.	7,094,247 B2	8/2006	Monassevitch et al.
6,974,462 B2	12/2005	Sater	7,097,089 B2	8/2006	Marczyk
6,978,921 B2	12/2005	Shelton, IV et al.	7,097,644 B2	8/2006	Long
6,978,922 B2	12/2005	Bilotti et al.	7,097,650 B2	8/2006	Weller et al.
6,981,628 B2	1/2006	Wales	7,098,794 B2	8/2006	Lindsay et al.
			7,100,949 B2	9/2006	Williams et al.
			7,104,741 B2	9/2006	Krohn
			7,108,695 B2	9/2006	Witt et al.
			7,108,701 B2	9/2006	Evens et al.

(56)

References Cited

U.S. PATENT DOCUMENTS

7,108,709 B2	9/2006	Cummins	7,252,660 B2	8/2007	Kunz
7,111,768 B2	9/2006	Cummins et al.	7,255,696 B2	8/2007	Goble et al.
7,111,769 B2	9/2006	Wales et al.	7,256,695 B2	8/2007	Hamel et al.
7,112,214 B2	9/2006	Peterson et al.	7,258,262 B2	8/2007	Mastri et al.
RE39,358 E	10/2006	Goble	7,258,546 B2	8/2007	Beier et al.
7,114,642 B2	10/2006	Whitman	7,260,431 B2	8/2007	Libbus et al.
7,118,582 B1	10/2006	Wang et al.	7,265,374 B2	9/2007	Lee et al.
7,121,446 B2	10/2006	Arad et al.	7,267,679 B2	9/2007	McGuckin, Jr. et al.
7,122,028 B2	10/2006	Looper et al.	7,267,682 B1	9/2007	Bender et al.
7,125,409 B2	10/2006	Truckai et al.	7,273,483 B2	9/2007	Wiener et al.
7,126,303 B2	10/2006	Farritor et al.	7,278,562 B2	10/2007	Mastri et al.
7,128,253 B2	10/2006	Mastri et al.	7,278,563 B1	10/2007	Green
7,128,254 B2	10/2006	Shelton, IV et al.	7,278,949 B2	10/2007	Bader
7,128,748 B2	10/2006	Mooradian et al.	7,278,994 B2	10/2007	Goble
7,131,445 B2	11/2006	Amoah	7,282,048 B2	10/2007	Goble et al.
7,133,601 B2	11/2006	Phillips et al.	7,286,850 B2	10/2007	Frielink et al.
7,134,587 B2	11/2006	Schwemberger et al.	7,287,682 B1	10/2007	Ezzat et al.
7,137,981 B2	11/2006	Long	7,293,685 B2	11/2007	Ehrenfels et al.
7,140,527 B2 *	11/2006	Ehrenfels A61B 17/07207 227/175.1	7,295,907 B2	11/2007	Lu et al.
7,140,528 B2	11/2006	Shelton, IV	7,296,722 B2	11/2007	Ivanko
7,143,923 B2	12/2006	Shelton, IV et al.	7,296,724 B2	11/2007	Green et al.
7,143,924 B2	12/2006	Scirica et al.	7,297,149 B2	11/2007	Vitali et al.
7,143,925 B2	12/2006	Shelton, IV et al.	7,300,373 B2	11/2007	Jinno et al.
7,143,926 B2	12/2006	Shelton, IV et al.	7,300,450 B2	11/2007	Vleugels et al.
7,147,138 B2	12/2006	Shelton, IV	7,303,106 B2	12/2007	Milliman et al.
7,147,139 B2	12/2006	Schwemberger et al.	7,303,107 B2	12/2007	Milliman et al.
7,147,140 B2	12/2006	Wukusick et al.	7,303,108 B2	12/2007	Shelton, IV
7,147,637 B2	12/2006	Goble	7,303,502 B2	12/2007	Thompson
7,147,650 B2	12/2006	Lee	7,303,556 B2	12/2007	Metzger
7,150,748 B2	12/2006	Ebbutt et al.	7,306,597 B2	12/2007	Manzo
7,153,300 B2	12/2006	Goble	7,308,998 B2	12/2007	Mastri et al.
7,156,863 B2	1/2007	Sonnenschein et al.	7,322,975 B2	1/2008	Goble et al.
7,159,750 B2	1/2007	Racenet et al.	7,322,994 B2	1/2008	Nicholas et al.
7,160,299 B2	1/2007	Baily	7,324,572 B2	1/2008	Chang
7,161,036 B2	1/2007	Oikawa et al.	7,326,203 B2	2/2008	Papineau et al.
7,168,604 B2	1/2007	Milliman et al.	7,326,213 B2	2/2008	Benderev et al.
7,172,104 B2	2/2007	Scirica et al.	7,328,828 B2	2/2008	Ortiz et al.
7,172,593 B2	2/2007	Trieu et al.	7,328,829 B2	2/2008	Arad et al.
7,179,223 B2	2/2007	Motoki et al.	7,330,004 B2	2/2008	DeJonge et al.
7,179,267 B2	2/2007	Nolan et al.	7,331,340 B2	2/2008	Barney
7,182,239 B1	2/2007	Myers	7,334,717 B2	2/2008	Rethy et al.
7,182,763 B2	2/2007	Nardella	7,334,718 B2	2/2008	McAlister et al.
7,183,737 B2	2/2007	Kitagawa	7,335,199 B2	2/2008	Goble et al.
7,188,758 B2	3/2007	Viola et al.	7,336,048 B2	2/2008	Lohr
7,189,207 B2	3/2007	Viola	7,336,184 B2	2/2008	Smith et al.
7,195,627 B2	3/2007	Amoah et al.	7,338,513 B2	3/2008	Lee et al.
7,199,537 B2	4/2007	Okamura et al.	7,341,591 B2	3/2008	Grinberg
7,202,653 B2	4/2007	Pai	7,343,920 B2	3/2008	Toby et al.
7,204,835 B2	4/2007	Latterell et al.	7,344,532 B2	3/2008	Goble et al.
7,207,233 B2	4/2007	Wadge	7,348,763 B1	3/2008	Reinhart et al.
7,207,471 B2	4/2007	Heinrich et al.	RE40,237 E	4/2008	Bilotti et al.
7,207,472 B2	4/2007	Wukusick et al.	7,351,258 B2	4/2008	Ricotta et al.
7,207,556 B2	4/2007	Saitoh et al.	7,354,447 B2	4/2008	Shelton, IV et al.
7,208,005 B2	4/2007	Frecker et al.	7,354,502 B2	4/2008	Polat et al.
7,210,609 B2	5/2007	Leiboff et al.	7,357,287 B2	4/2008	Shelton, IV et al.
7,211,081 B2	5/2007	Goble	7,357,806 B2	4/2008	Rivera et al.
7,211,084 B2	5/2007	Goble et al.	7,361,195 B2	4/2008	Schwartz et al.
7,211,092 B2	5/2007	Hughett	7,364,060 B2	4/2008	Milliman
7,213,736 B2	5/2007	Wales et al.	7,364,061 B2	4/2008	Swayze et al.
7,214,224 B2	5/2007	Goble	7,377,918 B2	5/2008	Amoah
7,214,232 B2	5/2007	Bowman et al.	7,377,928 B2	5/2008	Zubik et al.
7,217,285 B2	5/2007	Vargas et al.	7,380,695 B2	6/2008	Doll et al.
7,220,260 B2	5/2007	Fleming et al.	7,380,696 B2	6/2008	Shelton, IV et al.
7,220,272 B2	5/2007	Weadock	7,384,417 B2	6/2008	Cucin
7,225,963 B2	6/2007	Scirica	7,386,730 B2	6/2008	Uchikubo
7,225,964 B2	6/2007	Mastri et al.	7,388,217 B2	6/2008	Buschbeck et al.
7,234,624 B2	6/2007	Gresham et al.	7,391,173 B2	6/2008	Schena
7,235,089 B1	6/2007	McGuckin, Jr.	7,396,356 B2	7/2008	Mollenauer
7,235,302 B2	6/2007	Jing et al.	7,397,364 B2	7/2008	Govari
7,237,708 B1	7/2007	Guy et al.	7,398,907 B2	7/2008	Racenet et al.
7,238,195 B2	7/2007	Viola	7,398,908 B2	7/2008	Holsten et al.
7,241,288 B2	7/2007	Braun	7,400,752 B2	7/2008	Zacharias
7,246,734 B2	7/2007	Shelton, IV	7,401,721 B2	7/2008	Holsten et al.
7,247,161 B2	7/2007	Johnston et al.	7,404,508 B2	7/2008	Smith et al.
			7,404,509 B2	7/2008	Ortiz et al.
			7,404,822 B2	7/2008	Viart et al.
			7,407,074 B2	8/2008	Ortiz et al.
			7,407,075 B2	8/2008	Holsten et al.
			7,407,076 B2	8/2008	Racenet et al.

(56)

References Cited

U.S. PATENT DOCUMENTS

7,407,077 B2	8/2008	Ortiz et al.	7,549,563 B2	6/2009	Mather et al.
7,407,078 B2	8/2008	Shelton, IV et al.	7,549,564 B2	6/2009	Boudreaux
7,410,086 B2	8/2008	Ortiz et al.	7,549,998 B2	6/2009	Braun
7,413,563 B2	8/2008	Corcoran et al.	7,552,854 B2	6/2009	Wixey et al.
7,416,101 B2	8/2008	Shelton, IV et al.	7,556,185 B2	7/2009	Viola
7,418,078 B2	8/2008	Blanz et al.	7,556,186 B2	7/2009	Milliman
RE40,514 E	9/2008	Mastri et al.	7,556,647 B2	7/2009	Drews et al.
7,419,080 B2	9/2008	Smith et al.	7,559,449 B2	7/2009	Viola
7,419,081 B2	9/2008	Ehrenfels et al.	7,559,450 B2	7/2009	Wales et al.
7,419,495 B2	9/2008	Menn et al.	7,559,452 B2	7/2009	Wales et al.
7,422,136 B1	9/2008	Marczyk	7,559,937 B2	7/2009	de la Torre et al.
7,422,138 B2	9/2008	Bilotti et al.	7,563,862 B2	7/2009	Sieg et al.
7,422,139 B2	9/2008	Shelton, IV et al.	7,565,993 B2	7/2009	Milliman et al.
7,424,965 B2	9/2008	Racenet et al.	7,566,300 B2	7/2009	Devierre et al.
7,427,607 B2	9/2008	Suzuki	7,567,045 B2	7/2009	Fristedt
7,431,188 B1	10/2008	Marczyk	7,568,603 B2	8/2009	Shelton, IV et al.
7,431,189 B2	10/2008	Shelton, IV et al.	7,568,604 B2	8/2009	Ehrenfels et al.
7,431,694 B2	10/2008	Stefanchik et al.	7,568,619 B2	8/2009	Todd et al.
7,431,730 B2	10/2008	Viola	7,575,144 B2	8/2009	Ortiz et al.
7,434,715 B2	10/2008	Shelton, IV et al.	7,588,174 B2	9/2009	Holsten et al.
7,434,717 B2	10/2008	Shelton, IV et al.	7,588,175 B2	9/2009	Timm et al.
7,438,209 B1	10/2008	Hess et al.	7,588,176 B2	9/2009	Timm et al.
7,438,718 B2	10/2008	Milliman et al.	7,588,177 B2	9/2009	Racenet
7,439,354 B2	10/2008	Lenges et al.	7,591,783 B2	9/2009	Boulais et al.
7,441,684 B2	10/2008	Shelton, IV et al.	7,597,229 B2	10/2009	Boudreaux et al.
7,441,685 B1	10/2008	Boudreaux	7,597,230 B2	10/2009	Racenet et al.
7,442,201 B2	10/2008	Pugsley et al.	7,600,663 B2	10/2009	Green
7,448,525 B2	11/2008	Shelton, IV et al.	7,604,150 B2	10/2009	Boudreaux
7,451,904 B2	11/2008	Shelton, IV	7,604,151 B2	10/2009	Hess et al.
7,455,208 B2	11/2008	Wales et al.	7,607,557 B2	10/2009	Shelton, IV et al.
7,455,676 B2	11/2008	Holsten et al.	7,611,038 B2	11/2009	Racenet et al.
7,455,682 B2	11/2008	Viola	7,611,474 B2	11/2009	Hibner et al.
7,461,767 B2	12/2008	Viola et al.	7,615,003 B2	11/2009	Stefanchik et al.
7,462,187 B2	12/2008	Johnston et al.	7,615,067 B2	11/2009	Lee et al.
7,464,846 B2	12/2008	Shelton, IV et al.	7,617,961 B2	11/2009	Viola
7,464,847 B2	12/2008	Viola et al.	D605,762 S *	12/2009	Nalagatla D24/145
7,464,849 B2	12/2008	Shelton, IV et al.	7,624,902 B2	12/2009	Marczyk et al.
7,467,740 B2	12/2008	Shelton, IV et al.	7,624,903 B2	12/2009	Green et al.
7,467,849 B2	12/2008	Silverbrook et al.	7,625,370 B2	12/2009	Hart et al.
7,472,814 B2	1/2009	Mastri et al.	7,631,793 B2	12/2009	Rethy et al.
7,472,815 B2	1/2009	Shelton, IV et al.	7,631,794 B2	12/2009	Rethy et al.
7,472,816 B2	1/2009	Holsten et al.	7,635,074 B2	12/2009	Olson et al.
7,473,253 B2	1/2009	Dycus et al.	7,637,409 B2	12/2009	Marczyk
7,473,263 B2	1/2009	Johnston et al.	7,637,410 B2	12/2009	Marczyk
7,476,237 B2	1/2009	Taniguchi et al.	7,638,958 B2	12/2009	Philipp et al.
7,479,608 B2	1/2009	Smith	7,641,091 B2 *	1/2010	Olson A61B 17/07207 227/175.1
7,481,347 B2	1/2009	Roy	7,641,092 B2	1/2010	Kruszynski et al.
7,481,348 B2	1/2009	Marczyk	7,641,093 B2	1/2010	Doll et al.
7,481,349 B2	1/2009	Holsten et al.	7,641,095 B2	1/2010	Viola
7,481,824 B2	1/2009	Boudreaux et al.	7,644,783 B2	1/2010	Roberts et al.
7,485,133 B2	2/2009	Cannon et al.	7,644,848 B2	1/2010	Swayze et al.
7,485,142 B2	2/2009	Milo	7,645,230 B2	1/2010	Mikkaichi et al.
7,487,899 B2	2/2009	Shelton, IV et al.	7,648,457 B2	1/2010	Stefanchik et al.
7,490,749 B2	2/2009	Schall et al.	7,648,519 B2	1/2010	Lee et al.
7,494,039 B2	2/2009	Racenet et al.	7,651,017 B2	1/2010	Ortiz et al.
7,494,499 B2	2/2009	Nagase et al.	7,651,498 B2	1/2010	Shifrin et al.
7,494,501 B2	2/2009	Ahlberg et al.	7,654,431 B2	2/2010	Hueil et al.
7,500,979 B2	3/2009	Hueil et al.	7,655,288 B2	2/2010	Bauman et al.
7,501,198 B2	3/2009	Barley et al.	7,656,131 B2	2/2010	Embrey et al.
7,503,474 B2	3/2009	Hillstead et al.	7,658,311 B2	2/2010	Boudreaux
7,506,790 B2	3/2009	Shelton, IV	7,658,312 B2	2/2010	Vidal et al.
7,506,791 B2	3/2009	Omaits et al.	7,659,219 B2	2/2010	Biran et al.
7,507,202 B2	3/2009	Schoellhorn	7,662,161 B2	2/2010	Briganti et al.
7,510,107 B2	3/2009	Timm et al.	7,665,646 B2	2/2010	Prommersberger
7,510,566 B2	3/2009	Jacobs et al.	7,665,647 B2	2/2010	Shelton, IV et al.
7,513,408 B2	4/2009	Shelton, IV et al.	7,669,746 B2	3/2010	Shelton, IV
7,517,356 B2	4/2009	Heinrich	7,669,747 B2	3/2010	Weisenburgh, II et al.
7,524,320 B2	4/2009	Tierney et al.	7,670,334 B2	3/2010	Hueil et al.
7,530,984 B2	5/2009	Sonnenschein et al.	7,673,780 B2	3/2010	Shelton, IV et al.
7,530,985 B2	5/2009	Takemoto et al.	7,673,781 B2	3/2010	Swayze et al.
7,533,906 B2	5/2009	Luetgen et al.	7,673,782 B2	3/2010	Hess et al.
7,534,259 B2	5/2009	Lashinski et al.	7,673,783 B2	3/2010	Morgan et al.
7,546,939 B2	6/2009	Adams et al.	7,674,253 B2	3/2010	Fisher et al.
7,546,940 B2	6/2009	Milliman et al.	7,674,255 B2	3/2010	Braun
7,547,312 B2	6/2009	Bauman et al.	7,674,263 B2	3/2010	Ryan
			7,674,270 B2	3/2010	Layer
			7,682,307 B2	3/2010	Danitz et al.
			7,682,367 B2	3/2010	Shah et al.

(56)

References Cited

U.S. PATENT DOCUMENTS

7,686,201 B2	3/2010	Csiky	7,789,883 B2	9/2010	Takashino et al.
7,686,826 B2	3/2010	Lee et al.	7,789,889 B2	9/2010	Zubik et al.
7,688,028 B2	3/2010	Phillips et al.	7,793,812 B2	9/2010	Moore et al.
7,691,098 B2	4/2010	Wallace et al.	7,794,475 B2	9/2010	Hess et al.
7,691,106 B2	4/2010	Schenberger et al.	7,798,386 B2	9/2010	Schall et al.
7,694,865 B2	4/2010	Scirica	7,799,039 B2	9/2010	Shelton, IV et al.
7,695,485 B2	4/2010	Whitman et al.	7,799,044 B2	9/2010	Johnston et al.
7,699,204 B2	4/2010	Viola	7,799,965 B2	9/2010	Patel et al.
7,699,835 B2	4/2010	Lee et al.	7,803,151 B2	9/2010	Whitman
7,699,844 B2	4/2010	Utley et al.	7,806,871 B2	10/2010	Li et al.
7,699,846 B2	4/2010	Ryan	7,806,891 B2	10/2010	Nowlin et al.
7,699,856 B2	4/2010	Van Wyk et al.	7,810,690 B2	10/2010	Bilotti et al.
7,699,859 B2	4/2010	Bombard et al.	7,810,691 B2	10/2010	Boyden et al.
7,699,860 B2	4/2010	Huitema et al.	7,810,692 B2	10/2010	Hall et al.
7,703,653 B2	4/2010	Shah et al.	7,810,693 B2	10/2010	Broehl et al.
7,708,180 B2	5/2010	Murray et al.	7,815,092 B2	10/2010	Whitman et al.
7,708,181 B2	5/2010	Cole et al.	7,815,565 B2	10/2010	Stefanchik et al.
7,708,758 B2	5/2010	Lee et al.	7,819,296 B2	10/2010	Hueil et al.
7,714,239 B2	5/2010	Smith	7,819,297 B2	10/2010	Doll et al.
7,717,312 B2	5/2010	Beetel	7,819,298 B2	10/2010	Hall et al.
7,717,313 B2	5/2010	Criscuolo et al.	7,819,299 B2	10/2010	Shelton, IV et al.
7,717,846 B2	5/2010	Zirps et al.	7,819,884 B2	10/2010	Lee et al.
7,718,180 B2	5/2010	Karp	7,819,886 B2	10/2010	Whitfield et al.
7,718,556 B2	5/2010	Matsuda et al.	7,823,592 B2	11/2010	Bettuchi et al.
7,721,930 B2	5/2010	McKenna et al.	7,823,760 B2	11/2010	Zemlok et al.
7,721,931 B2	5/2010	Shelton, IV et al.	7,824,401 B2	11/2010	Manzo et al.
7,721,933 B2	5/2010	Ehrenfels et al.	7,824,426 B2	11/2010	Racenet et al.
7,721,934 B2	5/2010	Shelton, IV et al.	7,828,189 B2	11/2010	Holsten et al.
7,721,936 B2	5/2010	Shalton, IV et al.	7,828,794 B2	11/2010	Sartor
7,722,527 B2	5/2010	Bouchier et al.	7,828,808 B2	11/2010	Hinman et al.
7,722,607 B2	5/2010	Dumbauld et al.	7,832,408 B2	11/2010	Shelton, IV et al.
7,722,610 B2	5/2010	Viola et al.	7,832,611 B2	11/2010	Boyden et al.
7,726,537 B2	6/2010	Olson et al.	7,832,612 B2	11/2010	Baxter, III et al.
7,726,538 B2	6/2010	Holsten et al.	7,833,234 B2	11/2010	Bailly et al.
7,726,539 B2	6/2010	Holsten et al.	7,836,400 B2	11/2010	May et al.
7,727,954 B2	6/2010	McKay	7,837,079 B2	11/2010	Holsten et al.
7,729,742 B2	6/2010	Govari	7,837,080 B2	11/2010	Schwemberger
7,731,072 B2	6/2010	Timm et al.	7,837,081 B2	11/2010	Holsten et al.
7,731,073 B2	6/2010	Wixey et al.	7,837,694 B2	11/2010	Tethrake et al.
7,731,724 B2	6/2010	Huitema et al.	7,838,789 B2	11/2010	Stoffers et al.
7,735,703 B2	6/2010	Morgan et al.	7,841,503 B2	11/2010	Sonnenschein et al.
7,736,374 B2	6/2010	Vaughan et al.	7,842,025 B2	11/2010	Coleman et al.
7,738,971 B2	6/2010	Swayze et al.	7,842,028 B2	11/2010	Lee
7,740,159 B2	6/2010	Shelton, IV et al.	7,845,533 B2	12/2010	Marczyk et al.
7,743,960 B2	6/2010	Whitman et al.	7,845,534 B2	12/2010	Viola et al.
7,744,624 B2	6/2010	Bettuchi	7,845,535 B2	12/2010	Scirica
7,744,627 B2	6/2010	Orban, III et al.	7,845,536 B2	12/2010	Viola et al.
7,744,628 B2	6/2010	Viola	7,845,537 B2	12/2010	Shelton, IV et al.
7,748,587 B2	7/2010	Haramiishi et al.	7,846,149 B2	12/2010	Jankowski
7,749,204 B2	7/2010	Dhanaraj et al.	7,850,623 B2	12/2010	Griffin et al.
7,751,870 B2	7/2010	Whitman	7,850,642 B2	12/2010	Moll et al.
7,753,245 B2	7/2010	Boudreaux et al.	7,850,982 B2	12/2010	Stopek et al.
7,753,904 B2	7/2010	Shelton, IV et al.	7,854,736 B2	12/2010	Ryan
7,758,612 B2	7/2010	Shipp	7,857,183 B2	12/2010	Shelton, IV
7,766,207 B2	8/2010	Mather et al.	7,857,185 B2	12/2010	Swayze et al.
7,766,209 B2	8/2010	Baxter, III et al.	7,857,186 B2	12/2010	Baxter, III et al.
7,766,210 B2	8/2010	Shelton, IV et al.	7,857,813 B2	12/2010	Schmitz et al.
7,766,821 B2	8/2010	Brunnen et al.	7,861,906 B2	1/2011	Doll et al.
7,766,894 B2	8/2010	Weitzner et al.	7,862,579 B2	1/2011	Ortiz et al.
7,770,773 B2	8/2010	Whitman et al.	7,866,525 B2	1/2011	Scirica
7,770,774 B2	8/2010	Mastri et al.	7,866,527 B2	1/2011	Hall et al.
7,770,775 B2	8/2010	Shelton, IV et al.	7,866,528 B2	1/2011	Olson et al.
7,770,776 B2	8/2010	Chen et al.	7,870,989 B2	1/2011	Viola et al.
7,771,396 B2	8/2010	Stefanchik et al.	7,871,418 B2	1/2011	Thompson et al.
7,772,720 B2	8/2010	McGee et al.	7,879,070 B2	2/2011	Ortiz et al.
7,776,037 B2	8/2010	Odom	7,883,465 B2	2/2011	Donofrio et al.
7,776,060 B2	8/2010	Mooradian et al.	7,886,951 B2	2/2011	Hessler
7,778,004 B2	8/2010	Nerheim et al.	7,886,952 B2	2/2011	Scirica et al.
7,780,054 B2	8/2010	Wales	7,887,530 B2	2/2011	Zemlok et al.
7,780,055 B2	8/2010	Scirica et al.	7,887,535 B2	2/2011	Lands et al.
7,780,663 B2	8/2010	Yates et al.	7,887,563 B2	2/2011	Cummins
7,780,685 B2	8/2010	Hunt et al.	7,891,531 B1	2/2011	Ward
7,784,662 B2	8/2010	Wales et al.	7,891,532 B2	2/2011	Mastri et al.
7,784,663 B2	8/2010	Shelton, IV	7,893,586 B2	2/2011	West et al.
7,789,875 B2	9/2010	Brock et al.	7,896,214 B2	3/2011	Farascioni
			7,896,215 B2	3/2011	Adams et al.
			7,896,877 B2	3/2011	Hall et al.
			7,896,895 B2	3/2011	Boudreaux et al.
			7,900,805 B2	3/2011	Shelton, IV et al.

(56)

References Cited

U.S. PATENT DOCUMENTS

7,905,380 B2	3/2011	Shelton, IV et al.	8,007,511 B2	8/2011	Brock et al.
7,905,381 B2	3/2011	Baxter, III et al.	8,011,550 B2	9/2011	Aranyi et al.
7,905,889 B2	3/2011	Catanese, III et al.	8,011,551 B2	9/2011	Marczyk et al.
7,905,902 B2	3/2011	Huitema et al.	8,011,553 B2	9/2011	Mastri et al.
7,909,191 B2	3/2011	Baker et al.	8,011,555 B2	9/2011	Tarinelli et al.
7,909,220 B2	3/2011	Viola	8,012,170 B2	9/2011	Whitman et al.
7,909,221 B2	3/2011	Viola et al.	8,016,176 B2	9/2011	Kasvikis et al.
7,913,891 B2	3/2011	Doll et al.	8,016,177 B2	9/2011	Bettuchi et al.
7,913,893 B2	3/2011	Mastri et al.	8,016,178 B2	9/2011	Olson et al.
7,914,543 B2	3/2011	Roth et al.	8,016,855 B2	9/2011	Whitman et al.
7,914,551 B2	3/2011	Ortiz et al.	8,016,858 B2	9/2011	Whitman
7,918,230 B2	4/2011	Whitman et al.	8,016,881 B2	9/2011	Furst
7,918,376 B1	4/2011	Knodel et al.	8,020,742 B2	9/2011	Marczyk
7,918,377 B2	4/2011	Measamer et al.	8,020,743 B2	9/2011	Shelton, IV
7,918,848 B2	4/2011	Lau et al.	8,021,375 B2	9/2011	Aldrich et al.
7,918,867 B2	4/2011	Dana et al.	8,025,199 B2	9/2011	Whitman et al.
7,918,873 B2	4/2011	Cummins	8,028,883 B2	10/2011	Stopek
7,922,061 B2	4/2011	Shelton, IV et al.	8,028,884 B2	10/2011	Sniffin et al.
7,922,063 B2	4/2011	Zemlok et al.	8,028,885 B2	10/2011	Smith et al.
7,922,743 B2	4/2011	Heinrich et al.	8,034,077 B2	10/2011	Smith et al.
7,926,691 B2	4/2011	Viola et al.	8,034,363 B2	10/2011	Li et al.
7,927,328 B2	4/2011	Orszulak et al.	8,037,591 B2	10/2011	Spivey et al.
7,928,281 B2	4/2011	Augustine	8,038,045 B2	10/2011	Bettuchi et al.
7,931,660 B2	4/2011	Aranyi et al.	8,038,046 B2	10/2011	Smith et al.
7,931,695 B2	4/2011	Ringeisen	8,038,686 B2	10/2011	Huitema et al.
7,934,630 B2	5/2011	Shelton, IV et al.	8,043,207 B2	10/2011	Adams
7,934,631 B2	5/2011	Balbierz et al.	8,043,328 B2	10/2011	Hahnen et al.
7,935,773 B2	5/2011	Hadba et al.	8,047,236 B2	11/2011	Perry
7,938,307 B2	5/2011	Bettuchi	8,048,503 B2	11/2011	Farnsworth et al.
7,941,865 B2	5/2011	Seman, Jr. et al.	8,056,787 B2	11/2011	Boudreaux et al.
7,942,301 B2	5/2011	Sater	8,056,788 B2	11/2011	Mastri et al.
7,942,303 B2	5/2011	Shah	8,056,789 B1	11/2011	White et al.
7,942,890 B2	5/2011	D'Agostino et al.	8,057,508 B2	11/2011	Shelton, IV
7,944,175 B2	5/2011	Mori et al.	8,058,771 B2	11/2011	Giordano et al.
7,946,453 B2	5/2011	Voegele et al.	8,061,576 B2	11/2011	Cappola
7,950,560 B2	5/2011	Zemlok et al.	8,062,330 B2	11/2011	Prommersberger et al.
7,950,561 B2	5/2011	Aranyi	8,066,167 B2	11/2011	Measamer et al.
7,951,071 B2	5/2011	Whitman et al.	8,066,168 B2	11/2011	Vidal et al.
7,951,166 B2	5/2011	Orban, III et al.	D650,074 S	12/2011	Hunt et al.
7,954,682 B2	6/2011	Giordano et al.	8,070,033 B2	12/2011	Milliman et al.
7,954,684 B2	6/2011	Boudreaux	8,070,035 B2	12/2011	Holsten et al.
7,954,686 B2	6/2011	Baxter, III et al.	8,070,743 B2	12/2011	Kagan et al.
7,954,687 B2	6/2011	Zemlok et al.	8,075,571 B2	12/2011	Vitali et al.
7,954,688 B2	6/2011	Argentine et al.	8,083,118 B2	12/2011	Milliman et al.
7,955,257 B2	6/2011	Frasier et al.	8,083,119 B2	12/2011	Prommersberger
7,959,050 B2	6/2011	Smith et al.	8,083,120 B2	12/2011	Shelton, IV et al.
7,959,051 B2	6/2011	Smith et al.	8,084,001 B2	12/2011	Burns et al.
7,959,052 B2	6/2011	Sonnenschein et al.	8,085,013 B2	12/2011	Wei et al.
7,963,432 B2	6/2011	Knodel et al.	8,087,563 B2	1/2012	Milliman et al.
7,963,433 B2	6/2011	Whitman et al.	8,091,756 B2	1/2012	Viola
7,963,963 B2	6/2011	Francischelli et al.	8,092,443 B2	1/2012	Bischoff
7,963,964 B2	6/2011	Santilli et al.	8,092,932 B2	1/2012	Phillips et al.
7,966,799 B2	6/2011	Morgan et al.	8,096,458 B2	1/2012	Hessler
7,967,178 B2	6/2011	Scirica et al.	8,097,017 B2	1/2012	Viola
7,967,179 B2	6/2011	Olson et al.	8,100,310 B2	1/2012	Zemlok
7,967,180 B2	6/2011	Scirica	8,100,872 B2	1/2012	Patel
7,967,181 B2	6/2011	Viola et al.	8,102,278 B2	1/2012	Deck et al.
7,967,839 B2	6/2011	Flock et al.	8,105,350 B2	1/2012	Lee et al.
7,972,298 B2	7/2011	Wallace et al.	8,108,072 B2	1/2012	Zhao et al.
7,980,443 B2	7/2011	Scheib et al.	8,109,426 B2	2/2012	Milliman et al.
7,988,015 B2	8/2011	Mason, II et al.	8,110,208 B1	2/2012	Hen
7,988,026 B2	8/2011	Knodel et al.	8,113,405 B2	2/2012	Milliman
7,988,027 B2	8/2011	Olson et al.	8,113,410 B2	2/2012	Hall et al.
7,988,028 B2	8/2011	Farascioni et al.	8,114,100 B2	2/2012	Smith et al.
7,992,757 B2	8/2011	Wheeler et al.	8,123,103 B2	2/2012	Milliman
7,993,360 B2	8/2011	Hacker et al.	8,123,766 B2	2/2012	Bauman et al.
7,997,468 B2	8/2011	Farascioni	8,123,767 B2	2/2012	Bauman et al.
7,997,469 B2	8/2011	Olson et al.	8,127,975 B2	3/2012	Olson et al.
8,002,696 B2	8/2011	Suzuki	8,127,976 B2	3/2012	Scirica et al.
8,002,784 B2	8/2011	Jinno et al.	8,128,624 B2	3/2012	Couture et al.
8,002,785 B2	8/2011	Weiss et al.	8,128,643 B2	3/2012	Aranyi et al.
8,002,795 B2	8/2011	Beetel	8,128,645 B2	3/2012	Sonnenschein et al.
8,006,365 B2	8/2011	Levin et al.	8,132,703 B2	3/2012	Milliman et al.
8,006,885 B2	8/2011	Marczyk	8,132,706 B2	3/2012	Marczyk et al.
8,006,889 B2	8/2011	Adams et al.	8,136,712 B2	3/2012	Zingman
			8,136,713 B2	3/2012	Hathaway et al.
			8,140,417 B2	3/2012	Shibata
			8,141,762 B2	3/2012	Bedi et al.
			8,141,763 B2	3/2012	Milliman

(56)

References Cited

U.S. PATENT DOCUMENTS

8,146,790 B2	4/2012	Milliman	8,267,924 B2	9/2012	Zemlok et al.
8,147,485 B2	4/2012	Wham et al.	8,267,946 B2	9/2012	Whitfield et al.
8,152,041 B2	4/2012	Kostrzewski	8,267,951 B2	9/2012	Whayne et al.
8,157,145 B2	4/2012	Shelton, IV et al.	8,269,121 B2	9/2012	Smith
8,157,148 B2	4/2012	Scirica	8,272,553 B2	9/2012	Mastri et al.
8,157,151 B2	4/2012	Ingmanson et al.	8,272,554 B2	9/2012	Whitman et al.
8,157,152 B2	4/2012	Holsten et al.	8,272,918 B2	9/2012	Lam
8,157,153 B2	4/2012	Shelton, IV et al.	8,273,404 B2	9/2012	Dave et al.
8,157,793 B2	4/2012	Omori et al.	8,276,801 B2	10/2012	Zemlok et al.
8,161,977 B2	4/2012	Shelton, IV et al.	8,276,802 B2	10/2012	Kostrzewski
8,162,138 B2	4/2012	Bettenhausen et al.	8,281,973 B2	10/2012	Wenchell et al.
8,162,197 B2	4/2012	Mastri et al.	8,281,974 B2	10/2012	Hessler et al.
8,167,185 B2	5/2012	Shelton, IV et al.	8,285,367 B2	10/2012	Hyde et al.
8,167,895 B2	5/2012	D'Agostino et al.	8,286,845 B2	10/2012	Perry et al.
8,167,898 B1	5/2012	Schaller et al.	8,286,846 B2	10/2012	Smith et al.
8,170,241 B2	5/2012	Roe et al.	8,287,561 B2	10/2012	Nunez et al.
8,172,120 B2	5/2012	Boyden et al.	8,292,147 B2	10/2012	Viola
8,172,122 B2	5/2012	Kasvikis et al.	8,292,150 B2	10/2012	Bryant
8,172,124 B2	5/2012	Shelton, IV et al.	8,292,151 B2	10/2012	Viola
8,177,797 B2	5/2012	Shimoji et al.	8,292,152 B2	10/2012	Milliman et al.
8,180,458 B2	5/2012	Kane et al.	8,292,155 B2	10/2012	Shelton, IV et al.
8,181,840 B2	5/2012	Milliman	8,292,157 B2	10/2012	Smith et al.
8,186,555 B2	5/2012	Shelton, IV et al.	8,292,888 B2	10/2012	Whitman
8,186,556 B2	5/2012	Viola	8,298,161 B2	10/2012	Vargas
8,186,560 B2	5/2012	Hess et al.	8,298,677 B2	10/2012	Wiesner et al.
8,191,752 B2	6/2012	Scirica	8,302,323 B2	11/2012	Fortier et al.
8,192,460 B2	6/2012	Orban, III et al.	8,308,040 B2	11/2012	Huang et al.
8,196,795 B2	6/2012	Moore et al.	8,308,042 B2	11/2012	Aranyi
8,196,796 B2	6/2012	Shelton, IV et al.	8,308,046 B2	11/2012	Prommersberger
8,201,720 B2	6/2012	Hessler	8,308,659 B2	11/2012	Scheibe et al.
8,201,721 B2	6/2012	Zemlok et al.	8,313,496 B2	11/2012	Sauer et al.
8,202,549 B2	6/2012	Stucky et al.	8,313,509 B2	11/2012	Kostrzewski
8,205,779 B2	6/2012	Ma et al.	8,317,070 B2	11/2012	Hueil et al.
8,205,780 B2	6/2012	Sorrentino et al.	8,317,071 B1	11/2012	Knodel
8,205,781 B2	6/2012	Baxter, III et al.	8,317,074 B2	11/2012	Ortiz et al.
8,206,291 B2	6/2012	Fischvogt et al.	8,317,790 B2	11/2012	Bell et al.
8,210,411 B2	7/2012	Yates et al.	8,319,002 B2	11/2012	Daniels et al.
8,210,414 B2	7/2012	Bettuchi et al.	8,322,455 B2	12/2012	Shelton, IV et al.
8,210,415 B2	7/2012	Ward	8,322,589 B2	12/2012	Boudreaux
8,210,416 B2	7/2012	Milliman et al.	8,322,590 B2	12/2012	Patel et al.
8,211,125 B2	7/2012	Spivey	8,323,314 B2	12/2012	Blier
8,214,019 B2	7/2012	Govari et al.	8,323,789 B2	12/2012	Rozhin et al.
8,215,531 B2	7/2012	Shelton, IV et al.	8,328,061 B2	12/2012	Kasvikis
8,215,533 B2	7/2012	Viola et al.	8,328,062 B2	12/2012	Viola
8,220,468 B2	7/2012	Cooper et al.	8,328,063 B2	12/2012	Milliman et al.
8,220,688 B2	7/2012	Laurent et al.	8,328,064 B2	12/2012	Racenet et al.
8,220,690 B2	7/2012	Hess et al.	8,328,802 B2	12/2012	Deville et al.
8,221,424 B2	7/2012	Cha	8,328,823 B2	12/2012	Aranyi et al.
8,225,799 B2	7/2012	Bettuchi	8,333,313 B2	12/2012	Boudreaux et al.
8,225,980 B1	7/2012	Rivera	8,333,691 B2	12/2012	Schaaf
8,226,715 B2	7/2012	Hwang et al.	8,333,764 B2	12/2012	Francischelli et al.
8,227,946 B2	7/2012	Kim	8,336,753 B2	12/2012	Olson et al.
8,231,040 B2	7/2012	Zemlok et al.	8,336,754 B2	12/2012	Cappola et al.
8,231,041 B2	7/2012	Marczyk et al.	8,342,377 B2	1/2013	Milliman et al.
8,231,042 B2	7/2012	Hessler et al.	8,342,378 B2	1/2013	Marczyk et al.
8,231,043 B2	7/2012	Tarinelli et al.	8,342,379 B2	1/2013	Whitman et al.
8,236,010 B2	8/2012	Ortiz et al.	8,348,123 B2	1/2013	Scirica et al.
8,241,271 B2	8/2012	Millman et al.	8,348,125 B2	1/2013	Viola et al.
8,241,308 B2	8/2012	Kortenbach et al.	8,348,126 B2	1/2013	Olson et al.
8,241,322 B2	8/2012	Whitman et al.	8,348,127 B2	1/2013	Marczyk
8,245,594 B2	8/2012	Rogers et al.	8,348,129 B2	1/2013	Bedi et al.
8,245,898 B2	8/2012	Smith et al.	8,348,130 B2	1/2013	Shah et al.
8,245,899 B2	8/2012	Swensgard et al.	8,348,131 B2	1/2013	Omaits et al.
8,245,900 B2	8/2012	Scirica	8,348,972 B2	1/2013	Soltz et al.
8,245,901 B2	8/2012	Stopek	8,353,437 B2	1/2013	Boudreaux
8,246,637 B2	8/2012	Viola et al.	8,353,438 B2	1/2013	Baxter, III et al.
8,256,654 B2	9/2012	Bettuchi et al.	8,353,439 B2	1/2013	Baxter, III et al.
8,256,655 B2	9/2012	Sniffin et al.	8,356,740 B1	1/2013	Knodel
8,256,656 B2	9/2012	Milliman et al.	8,357,144 B2	1/2013	Whitman et al.
8,257,251 B2	9/2012	Shelton, IV et al.	8,360,296 B2	1/2013	Zingman
8,257,356 B2	9/2012	Bleich et al.	8,360,297 B2	1/2013	Shelton, IV et al.
8,257,391 B2	9/2012	Orban, III et al.	8,360,298 B2	1/2013	Farascioni et al.
8,257,634 B2	9/2012	Scirica	8,360,299 B2	1/2013	Zemlok et al.
8,262,655 B2	9/2012	Ghabrial et al.	8,361,501 B2	1/2013	DiTizio et al.
8,267,300 B2	9/2012	Boudreaux	8,365,973 B1	2/2013	White et al.
			8,365,975 B1	2/2013	Manoux et al.
			8,365,976 B2	2/2013	Hess et al.
			8,366,559 B2	2/2013	Papenfuss et al.
			8,366,787 B2	2/2013	Brown et al.

(56)

References Cited

U.S. PATENT DOCUMENTS

8,371,491 B2	2/2013	Huitema et al.	8,506,580 B2	8/2013	Zergiebel et al.
8,371,492 B2	2/2013	Aranyi et al.	8,506,581 B2	8/2013	Wingardner, III et al.
8,371,493 B2	2/2013	Aranyi et al.	8,512,359 B2	8/2013	Whitman et al.
8,372,094 B2	2/2013	Bettuchi et al.	8,517,239 B2	8/2013	Scheib et al.
8,376,865 B2	2/2013	Forster et al.	8,517,241 B2	8/2013	Nicholas et al.
8,377,044 B2	2/2013	Coe et al.	8,517,243 B2	8/2013	Giordano et al.
8,387,848 B2 *	3/2013	Johnson A61B 17/07207 227/175.1	8,517,244 B2	8/2013	Shelton, IV et al.
8,388,633 B2	3/2013	Rousseau et al.	8,521,273 B2	8/2013	Kliman
8,393,513 B2	3/2013	Jankowski	8,523,043 B2	9/2013	Ullrich et al.
8,393,514 B2	3/2013	Shelton, IV et al.	8,523,881 B2	9/2013	Cabiri et al.
8,393,516 B2	3/2013	Kostrzewski	8,523,900 B2	9/2013	Jinno et al.
8,397,971 B2	3/2013	Yates et al.	8,529,588 B2	9/2013	Ahlberg et al.
8,397,973 B1	3/2013	Hausen	8,529,600 B2	9/2013	Woodard, Jr. et al.
8,398,673 B2	3/2013	Hinchliffe et al.	8,529,819 B2	9/2013	Ostapoff et al.
8,403,138 B2	3/2013	Weisshaupt et al.	8,532,747 B2	9/2013	Nock et al.
8,403,198 B2	3/2013	Sorrentino et al.	8,534,528 B2	9/2013	Shelton, IV
8,403,945 B2	3/2013	Whitfield et al.	8,535,304 B2	9/2013	Sklar et al.
8,403,950 B2	3/2013	Palmer et al.	8,540,128 B2	9/2013	Shelton, IV et al.
8,408,439 B2	4/2013	Huang et al.	8,540,129 B2	9/2013	Baxter, III et al.
8,408,442 B2	4/2013	Racenet et al.	8,540,130 B2	9/2013	Moore et al.
8,409,079 B2	4/2013	Okamoto et al.	8,540,131 B2	9/2013	Swayze
8,409,174 B2	4/2013	Omori	8,540,133 B2	9/2013	Bedi et al.
8,409,222 B2	4/2013	Whitfield et al.	8,540,733 B2	9/2013	Whitman et al.
8,409,223 B2	4/2013	Sorrentino et al.	8,540,735 B2	9/2013	Mitelberg et al.
8,413,870 B2	4/2013	Pastorelli et al.	8,550,984 B2	10/2013	Takemoto
8,413,871 B2	4/2013	Racenet et al.	8,551,076 B2	10/2013	Duval et al.
8,413,872 B2	4/2013	Patel	8,556,151 B2	10/2013	Viola
8,414,577 B2	4/2013	Boudreaux et al.	8,556,918 B2	10/2013	Bauman et al.
8,418,908 B1	4/2013	Beardsley	8,556,935 B1	10/2013	Knodel et al.
8,418,909 B2	4/2013	Kostrzewski	8,561,870 B2	10/2013	Baxter, III et al.
8,424,737 B2	4/2013	Scirica	8,561,873 B2	10/2013	Ingmanson et al.
8,424,739 B2	4/2013	Racenet et al.	8,567,656 B2	10/2013	Shelton, IV et al.
8,424,740 B2	4/2013	Shelton, IV et al.	8,573,459 B2	11/2013	Smith et al.
8,424,741 B2	4/2013	McGuckin, Jr. et al.	8,573,461 B2	11/2013	Shelton, IV et al.
8,425,600 B2	4/2013	Maxwell	8,573,462 B2	11/2013	Smith et al.
8,430,292 B2	4/2013	Patel et al.	8,573,465 B2	11/2013	Shelton, IV
8,430,892 B2	4/2013	Bindra et al.	8,574,263 B2	11/2013	Mueller
8,430,898 B2	4/2013	Wiener et al.	8,579,176 B2	11/2013	Smith et al.
8,439,246 B1	5/2013	Knodel	8,579,178 B2	11/2013	Holsten et al.
8,444,036 B2	5/2013	Shelton, IV	8,579,937 B2	11/2013	Gresham
8,444,549 B2	5/2013	Viola et al.	8,579,938 B2	11/2013	Heinrich et al.
8,453,904 B2	6/2013	Eskaros et al.	8,584,919 B2	11/2013	Hueil et al.
8,453,906 B2	6/2013	Huang et al.	8,585,721 B2	11/2013	Kirsch
8,453,907 B2	6/2013	Laurent et al.	8,590,760 B2	11/2013	Cummins et al.
8,453,908 B2	6/2013	Bedi et al.	8,590,762 B2 *	11/2013	Hess A61B 17/07207 227/175.1
8,453,912 B2	6/2013	Mastri et al.	8,590,764 B2	11/2013	Hartwick et al.
8,453,914 B2	6/2013	Laurent et al.	8,602,287 B2	12/2013	Yates et al.
8,454,628 B2	6/2013	Smith et al.	8,602,288 B2	12/2013	Shelton, IV et al.
8,454,640 B2	6/2013	Johnston et al.	8,603,135 B2	12/2013	Mueller
8,457,757 B2	6/2013	Cauler et al.	8,608,043 B2	12/2013	Scirica
8,459,520 B2	6/2013	Giordano et al.	8,608,044 B2	12/2013	Hueil et al.
8,459,525 B2	6/2013	Yates et al.	8,608,045 B2	12/2013	Smith et al.
8,464,922 B2	6/2013	Marczyk	8,608,046 B2	12/2013	Laurent et al.
8,464,923 B2	6/2013	Shelton, IV	8,608,745 B2	12/2013	Guzman et al.
8,464,924 B2	6/2013	Gresham et al.	8,613,383 B2	12/2013	Beckman et al.
8,464,925 B2	6/2013	Hull et al.	8,616,431 B2	12/2013	Timm et al.
8,465,502 B2	6/2013	Zergiebel	8,622,274 B2	1/2014	Yates et al.
8,469,973 B2	6/2013	Meade et al.	8,622,275 B2	1/2014	Baxter, III et al.
8,474,677 B2	7/2013	Woodard, Jr. et al.	8,627,993 B2	1/2014	Smith et al.
8,475,453 B2	7/2013	Marczyk et al.	8,627,995 B2	1/2014	Smith et al.
8,475,474 B2	7/2013	Bombard et al.	8,628,518 B2	1/2014	Blumenkranz et al.
8,475,491 B2	7/2013	Milo	8,631,987 B2	1/2014	Shelton, IV et al.
8,479,969 B2	7/2013	Shelton, IV	8,631,992 B1	1/2014	Hausen et al.
8,480,703 B2	7/2013	Nicholas et al.	8,631,993 B2	1/2014	Kostrzewski
8,485,412 B2	7/2013	Shelton, IV et al.	8,632,462 B2	1/2014	Yoo et al.
8,485,413 B2	7/2013	Scheib et al.	8,632,525 B2	1/2014	Kerr et al.
8,490,853 B2	7/2013	Criscuolo et al.	8,632,535 B2	1/2014	Shelton, IV et al.
8,491,603 B2	7/2013	Yeung et al.	8,632,563 B2	1/2014	Nagase et al.
8,496,156 B2	7/2013	Sniffin et al.	8,636,187 B2	1/2014	Hueil et al.
8,496,683 B2	7/2013	Prommersberger et al.	8,636,191 B2	1/2014	Meagher
8,499,992 B2	8/2013	Whitman et al.	8,636,193 B2	1/2014	Whitman et al.
8,499,993 B2	8/2013	Shelton, IV et al.	8,636,736 B2	1/2014	Yates et al.
8,500,762 B2	8/2013	Sholev et al.	8,636,766 B2	1/2014	Milliman et al.
8,506,557 B2	8/2013	Zemlok et al.	8,640,788 B2	2/2014	Dachs, II et al.
			8,646,674 B2	2/2014	Schulte et al.
			8,647,258 B2	2/2014	Aranyi et al.
			8,652,120 B2	2/2014	Giordano et al.
			8,652,151 B2	2/2014	Lehman et al.

(56)

References Cited

U.S. PATENT DOCUMENTS

8,657,174 B2	2/2014	Yates et al.	8,784,404 B2	7/2014	Doyle et al.
8,657,176 B2	2/2014	Shelton, IV et al.	8,784,415 B2	7/2014	Malackowski et al.
8,657,177 B2	2/2014	Scirica et al.	8,789,737 B2	7/2014	Hodgkinson et al.
8,657,178 B2	2/2014	Hueil et al.	8,789,739 B2	7/2014	Swensgard
8,657,814 B2	2/2014	Werneth et al.	8,789,740 B2	7/2014	Baxter, III et al.
8,662,370 B2	3/2014	Takei	8,789,741 B2	7/2014	Baxter, III et al.
8,663,192 B2	3/2014	Hester et al.	8,790,684 B2	7/2014	Dave et al.
8,664,792 B2	3/2014	Rebsdorf	8,794,496 B2	8/2014	Scirica
8,668,129 B2	3/2014	Olson	8,794,497 B2	8/2014	Zingman
8,668,130 B2	3/2014	Hess et al.	8,795,276 B2	8/2014	Dietz et al.
8,672,206 B2	3/2014	Aranyi et al.	8,800,837 B2	8/2014	Zemlok
8,672,207 B2	3/2014	Shelton, IV et al.	8,800,838 B2	8/2014	Shelton, IV
8,672,208 B2	3/2014	Hess et al.	8,800,840 B2	8/2014	Jankowski
8,672,951 B2	3/2014	Smith et al.	8,800,841 B2	8/2014	Ellerhorst et al.
8,678,263 B2	3/2014	Viola	8,801,732 B2	8/2014	Harris et al.
8,679,093 B2	3/2014	Farra	8,801,734 B2	8/2014	Shelton, IV et al.
8,679,137 B2	3/2014	Bauman et al.	8,801,735 B2	8/2014	Shelton, IV et al.
8,679,154 B2	3/2014	Smith et al.	8,801,752 B2	8/2014	Fortier et al.
8,679,156 B2	3/2014	Smith et al.	8,806,973 B2	8/2014	Ross et al.
8,679,454 B2	3/2014	Guire et al.	8,808,294 B2	8/2014	Fox et al.
8,684,250 B2	4/2014	Bettuchi et al.	8,808,311 B2	8/2014	Heinrich et al.
8,684,253 B2	4/2014	Giordano et al.	8,808,325 B2	8/2014	Hess et al.
8,685,020 B2	4/2014	Weizman et al.	8,814,024 B2	8/2014	Woodard, Jr. et al.
8,695,866 B2	4/2014	Leimbach et al.	8,814,025 B2	8/2014	Miller et al.
8,696,665 B2	4/2014	Hunt et al.	8,820,603 B2	9/2014	Shelton, IV et al.
8,701,958 B2	4/2014	Shelton, IV et al.	8,820,605 B2	9/2014	Shelton, IV
8,701,959 B2	4/2014	Shah	8,820,606 B2	9/2014	Hodgkinson
8,708,210 B2	4/2014	Zemlok et al.	8,827,133 B2	9/2014	Shelton, IV et al.
8,708,211 B2	4/2014	Zemlok et al.	8,827,134 B2	9/2014	Viola et al.
8,708,213 B2	4/2014	Shelton, IV et al.	8,827,903 B2	9/2014	Shelton, IV et al.
8,714,429 B2	5/2014	Demmy	8,833,632 B2	9/2014	Swensgard
8,720,766 B2	5/2014	Hess et al.	8,834,498 B2	9/2014	Byrum et al.
8,721,630 B2	5/2014	Ortiz et al.	8,840,003 B2	9/2014	Morgan et al.
8,721,646 B2	5/2014	Fox	8,840,603 B2	9/2014	Shelton, IV et al.
8,721,666 B2	5/2014	Schroeder et al.	8,844,789 B2	9/2014	Shelton, IV et al.
8,727,197 B2	5/2014	Hess et al.	8,851,354 B2	10/2014	Swensgard et al.
8,728,119 B2	5/2014	Cummins	8,852,185 B2	10/2014	Twomey
8,728,120 B2	5/2014	Blier	8,852,199 B2	10/2014	Deslauriers et al.
8,733,612 B2	5/2014	Ma	8,857,693 B2	10/2014	Schuckmann et al.
8,733,613 B2 *	5/2014	Huitema A61B 17/07207 227/175.1	8,857,694 B2	10/2014	Shelton, IV et al.
8,733,614 B2	5/2014	Ross et al.	8,858,538 B2	10/2014	Belson et al.
8,734,478 B2	5/2014	Widenhouse et al.	8,858,571 B2	10/2014	Shelton, IV et al.
D706,927 S	6/2014	Cheney et al.	8,858,590 B2	10/2014	Shelton, IV et al.
8,740,034 B2	6/2014	Morgan et al.	8,864,007 B2	10/2014	Widenhouse et al.
8,740,037 B2	6/2014	Shelton, IV et al.	8,864,009 B2	10/2014	Shelton, IV et al.
8,740,038 B2	6/2014	Shelton, IV et al.	8,870,049 B2	10/2014	Amid et al.
8,746,529 B2	6/2014	Shelton, IV et al.	8,870,050 B2	10/2014	Hodgkinson
8,746,530 B2	6/2014	Giordano et al.	8,870,912 B2	10/2014	Brisson et al.
8,746,533 B2	6/2014	Whitman et al.	8,875,971 B2	11/2014	Hall et al.
8,746,535 B2	6/2014	Shelton, IV et al.	8,875,972 B2	11/2014	Weisenburgh, II et al.
8,747,238 B2	6/2014	Shelton, IV et al.	8,876,857 B2	11/2014	Burbank
8,752,264 B2	6/2014	Ackley et al.	8,876,858 B2	11/2014	Braun
8,752,699 B2	6/2014	Morgan et al.	8,888,792 B2	11/2014	Harris et al.
8,752,747 B2	6/2014	Shelton, IV et al.	8,893,946 B2	11/2014	Boudreaux et al.
8,752,749 B2	6/2014	Moore et al.	8,893,949 B2	11/2014	Shelton, IV et al.
8,757,287 B2	6/2014	Mak et al.	8,899,463 B2	12/2014	Schall et al.
8,757,465 B2	6/2014	Woodard, Jr. et al.	8,899,464 B2	12/2014	Hueil et al.
8,758,235 B2	6/2014	Jaworek	8,899,465 B2	12/2014	Shelton, IV et al.
8,758,366 B2	6/2014	McLean et al.	8,899,466 B2	12/2014	Baxter, III et al.
8,758,391 B2	6/2014	Swayze et al.	8,905,977 B2	12/2014	Shelton et al.
8,758,438 B2	6/2014	Boyce et al.	8,911,426 B2	12/2014	Coppeta et al.
8,763,875 B2	7/2014	Morgan et al.	8,911,471 B2	12/2014	Spivey et al.
8,763,877 B2	7/2014	Schall et al.	8,920,435 B2	12/2014	Smith et al.
8,763,879 B2	7/2014	Shelton, IV et al.	8,920,438 B2	12/2014	Aranyi et al.
8,770,458 B2	7/2014	Scirica	8,920,443 B2	12/2014	Hiles et al.
8,770,459 B2	7/2014	Racenet et al.	8,920,444 B2	12/2014	Hiles et al.
8,770,460 B2	7/2014	Belzer	8,925,782 B2	1/2015	Shelton, IV
8,771,169 B2	7/2014	Whitman et al.	8,925,783 B2	1/2015	Zemlok et al.
8,771,312 B1	7/2014	Knodel et al.	8,925,788 B2	1/2015	Hess et al.
8,777,004 B2	7/2014	Shelton, IV et al.	8,926,598 B2	1/2015	Mollere et al.
8,783,541 B2	7/2014	Shelton, IV et al.	8,931,682 B2	1/2015	Timm et al.
8,783,542 B2	7/2014	Riestenberg et al.	8,936,614 B2	1/2015	Allen, IV
8,783,543 B2	7/2014	Shelton, IV et al.	8,939,343 B2	1/2015	Milliman et al.
8,784,304 B2	7/2014	Mikkaichi et al.	8,939,344 B2	1/2015	Olson et al.
			8,955,732 B2	2/2015	Zemlok et al.
			8,956,390 B2	2/2015	Shah et al.
			8,960,519 B2	2/2015	Whitman et al.
			8,960,520 B2	2/2015	McCuen
			8,960,521 B2	2/2015	Kostrzewski

(56)

References Cited

U.S. PATENT DOCUMENTS

8,967,443 B2	3/2015	McCuen	9,113,884 B2	8/2015	Shelton, IV et al.
8,967,446 B2	3/2015	Beardsley et al.	9,119,657 B2	9/2015	Shelton, IV et al.
8,967,448 B2	3/2015	Carter et al.	9,119,898 B2	9/2015	Bayon et al.
8,968,276 B2	3/2015	Zemlok et al.	9,119,957 B2	9/2015	Gantz et al.
8,968,337 B2	3/2015	Whitfield et al.	9,123,286 B2	9/2015	Park
8,968,355 B2	3/2015	Malkowski et al.	9,125,649 B2	9/2015	Bruewer et al.
8,968,358 B2	3/2015	Reschke	9,125,654 B2	9/2015	Aronhalt et al.
8,973,803 B2	3/2015	Hall et al.	9,125,662 B2	9/2015	Shelton, IV
8,973,804 B2	3/2015	Hess et al.	9,131,940 B2	9/2015	Huitema et al.
8,974,440 B2	3/2015	Farritor et al.	9,138,225 B2	9/2015	Huang et al.
8,978,954 B2	3/2015	Shelton, IV et al.	9,138,226 B2	9/2015	Racenet et al.
8,978,955 B2	3/2015	Aronhalt et al.	9,149,274 B2	10/2015	Spivey et al.
8,978,956 B2	3/2015	Schall et al.	9,149,325 B2	10/2015	Worrell et al.
8,979,890 B2	3/2015	Boudreaux	9,168,038 B2	10/2015	Shelton, IV et al.
8,982,195 B2	3/2015	Claus et al.	9,168,039 B1	10/2015	Knodel
8,991,676 B2	3/2015	Hess et al.	9,179,911 B2	11/2015	Morgan et al.
8,991,677 B2	3/2015	Moore et al.	9,179,912 B2	11/2015	Yates et al.
8,991,678 B2	3/2015	Wellman et al.	9,186,046 B2	11/2015	Ramamurthy et al.
8,992,422 B2	3/2015	Spivey et al.	9,186,137 B2	11/2015	Farascioni et al.
8,996,165 B2	3/2015	Wang et al.	9,186,140 B2	11/2015	Hiles et al.
8,998,058 B2	4/2015	Moore et al.	9,186,143 B2	11/2015	Timm et al.
8,998,059 B2	4/2015	Smith et al.	9,192,380 B2	11/2015	(Tarinelli) Racenet et al.
8,998,061 B2	4/2015	Williams et al.	9,192,384 B2	11/2015	Bettuchi
9,004,339 B1	4/2015	Park	9,198,661 B2	12/2015	Swensgard
9,005,230 B2	4/2015	Yates et al.	9,198,662 B2	12/2015	Barton et al.
9,005,243 B2	4/2015	Stopek et al.	9,204,830 B2	12/2015	Zand et al.
9,010,608 B2	4/2015	Casasanta, Jr. et al.	9,204,877 B2	12/2015	Whitman et al.
9,016,540 B2	4/2015	Whitman et al.	9,204,878 B2	12/2015	Hall et al.
9,016,541 B2	4/2015	Viola et al.	9,204,879 B2	12/2015	Shelton, IV
9,016,542 B2	4/2015	Shelton, IV et al.	9,204,880 B2	12/2015	Baxter, III et al.
9,017,331 B2	4/2015	Fox	9,204,923 B2	12/2015	Manzo et al.
9,023,014 B2	5/2015	Chowaniec et al.	9,211,120 B2	12/2015	Scheib et al.
9,027,817 B2	5/2015	Milliman et al.	9,211,121 B2	12/2015	Hall et al.
9,028,494 B2	5/2015	Shelton, IV et al.	9,211,122 B2	12/2015	Hagerty et al.
9,028,495 B2	5/2015	Mueller et al.	9,216,019 B2	12/2015	Schmid et al.
9,028,519 B2	5/2015	Yates et al.	9,216,062 B2	12/2015	Duque et al.
9,033,203 B2	5/2015	Woodard, Jr. et al.	9,220,500 B2	12/2015	Swayze et al.
9,033,204 B2	5/2015	Shelton, IV et al.	9,220,501 B2	12/2015	Baxter, III et al.
9,038,881 B1	5/2015	Schaller et al.	9,220,502 B2	12/2015	Zemlok et al.
9,044,227 B2	6/2015	Shelton, IV et al.	9,226,751 B2	1/2016	Shelton, IV et al.
9,044,228 B2	6/2015	Woodard, Jr. et al.	9,232,941 B2	1/2016	Mandakolathur Vasudevan et al.
9,044,229 B2	6/2015	Scheib et al.	9,232,945 B2	1/2016	Zingman
9,044,230 B2	6/2015	Morgan et al.	9,237,891 B2	1/2016	Shelton, IV
9,050,083 B2	6/2015	Yates et al.	9,237,892 B2	1/2016	Hodgkinson
9,050,084 B2	6/2015	Schmid et al.	9,241,714 B2	1/2016	Timm et al.
9,050,120 B2	6/2015	Swarup et al.	9,265,500 B2	2/2016	Sorrentino et al.
9,055,941 B2	6/2015	Schmid et al.	9,271,753 B2	3/2016	Butler et al.
9,055,942 B2	6/2015	Balbierz et al.	9,271,799 B2	3/2016	Shelton, IV et al.
9,055,943 B2	6/2015	Zemlok et al.	9,272,406 B2	3/2016	Aronhalt et al.
9,055,944 B2	6/2015	Hodgkinson et al.	9,277,919 B2	3/2016	Timmer et al.
9,060,770 B2	6/2015	Shelton, IV et al.	9,277,922 B2	3/2016	Carter et al.
9,060,894 B2	6/2015	Wubbeling	9,282,962 B2	3/2016	Schmid et al.
9,072,515 B2	7/2015	Hall et al.	9,282,963 B2	3/2016	Bryant
9,072,523 B2	7/2015	Houser et al.	9,282,966 B2	3/2016	Shelton, IV et al.
9,072,535 B2	7/2015	Shelton, IV et al.	9,282,974 B2	3/2016	Shelton, IV
9,072,536 B2	7/2015	Shelton, IV et al.	9,283,054 B2	3/2016	Morgan et al.
9,078,653 B2	7/2015	Leimbach et al.	9,289,206 B2	3/2016	Hess et al.
9,084,601 B2	7/2015	Moore et al.	9,289,207 B2	3/2016	Shelton, IV
9,084,602 B2	7/2015	Gleiman	9,289,210 B2	3/2016	Baxter, III et al.
9,089,326 B2	7/2015	Krumanaker et al.	9,289,212 B2	3/2016	Shelton, IV et al.
9,089,330 B2	7/2015	Widenhouse et al.	9,289,225 B2	3/2016	Shelton, IV et al.
9,095,339 B2	8/2015	Moore et al.	9,289,256 B2	3/2016	Shelton, IV et al.
9,095,362 B2	8/2015	Dachs, II et al.	9,295,464 B2	3/2016	Shelton, IV et al.
9,096,033 B2	8/2015	Holop et al.	9,295,466 B2	3/2016	Hodgkinson et al.
9,101,358 B2	8/2015	Kerr et al.	9,301,752 B2	4/2016	Mandakolathur Vasudevan et al.
9,101,385 B2	8/2015	Shelton, IV et al.	9,301,753 B2	4/2016	Aldridge et al.
9,107,663 B2	8/2015	Swensgard	9,301,755 B2	4/2016	Shelton, IV et al.
9,110,587 B2	8/2015	Kim et al.	9,301,759 B2	4/2016	Spivey et al.
9,113,862 B2	8/2015	Morgan et al.	9,307,965 B2	4/2016	Ming et al.
9,113,864 B2	8/2015	Morgan et al.	9,307,986 B2	4/2016	Hall et al.
9,113,865 B2	8/2015	Shelton, IV et al.	9,307,987 B2	4/2016	Swensgard et al.
9,113,874 B2	8/2015	Shelton, IV et al.	9,307,988 B2	4/2016	Shelton, IV
9,113,880 B2	8/2015	Zemlok et al.	9,307,989 B2	4/2016	Shelton, IV et al.
9,113,881 B2	8/2015	Scirica	9,307,994 B2	4/2016	Gresham et al.
9,113,883 B2	8/2015	Aronhalt et al.	9,308,009 B2	4/2016	Madan et al.
			9,314,246 B2	4/2016	Shelton, IV et al.
			9,314,247 B2	4/2016	Shelton, IV et al.
			9,320,518 B2	4/2016	Henderson et al.
			9,320,520 B2	4/2016	Shelton, IV et al.

(56)

References Cited

U.S. PATENT DOCUMENTS

9,320,521 B2	4/2016	Shelton, IV et al.	9,561,032 B2	2/2017	Shelton, IV et al.
9,320,523 B2	4/2016	Shelton, IV et al.	9,561,038 B2	2/2017	Shelton, IV et al.
9,326,767 B2	5/2016	Koch, Jr. et al.	9,561,045 B2	2/2017	Hinman et al.
9,326,768 B2	5/2016	Shelton, IV	9,566,061 B2	2/2017	Aronhalt et al.
9,326,769 B2	5/2016	Shelton, IV et al.	9,572,574 B2	2/2017	Shelton, IV et al.
9,326,770 B2	5/2016	Shelton, IV et al.	9,572,577 B2	2/2017	Lloyd et al.
9,326,771 B2	5/2016	Baxter, III et al.	9,574,644 B2	2/2017	Parihar
9,332,974 B2	5/2016	Henderson et al.	9,585,657 B2	3/2017	Shelton, IV et al.
9,332,984 B2	5/2016	Weaner et al.	9,585,658 B2	3/2017	Shelton, IV
9,332,987 B2	5/2016	Leimbach et al.	9,585,660 B2	3/2017	Laurent et al.
9,333,082 B2	5/2016	Wei et al.	9,585,662 B2	3/2017	Shelton, IV et al.
9,345,477 B2	5/2016	Anim et al.	9,585,663 B2	3/2017	Shelton, IV et al.
9,345,481 B2	5/2016	Hall et al.	9,592,050 B2	3/2017	Schmid et al.
9,351,726 B2	5/2016	Leimbach et al.	9,592,052 B2	3/2017	Shelton, IV
9,351,727 B2	5/2016	Leimbach et al.	9,592,053 B2	3/2017	Shelton, IV et al.
9,351,730 B2	5/2016	Schmid et al.	9,592,054 B2	3/2017	Schmid et al.
9,351,731 B2	5/2016	Carter et al.	9,597,073 B2	3/2017	Sorrentino et al.
9,358,003 B2	6/2016	Hall et al.	9,597,074 B2	3/2017	Felder et al.
9,358,005 B2	6/2016	Shelton, IV et al.	9,597,075 B2	3/2017	Shelton, IV et al.
9,358,015 B2	6/2016	Sorrentino et al.	9,597,080 B2	3/2017	Milliman et al.
9,364,219 B2	6/2016	Olson et al.	9,603,595 B2	3/2017	Shelton, IV et al.
9,364,220 B2	6/2016	Williams	9,603,598 B2	3/2017	Shelton, IV et al.
9,364,229 B2	6/2016	D'Agostino et al.	9,603,991 B2	3/2017	Shelton, IV et al.
9,364,230 B2	6/2016	Shelton, IV et al.	9,610,080 B2	4/2017	Whitfield et al.
9,364,233 B2	6/2016	Alexander, III et al.	9,615,826 B2	4/2017	Shelton, IV et al.
9,370,358 B2	6/2016	Shelton, IV et al.	9,629,623 B2	4/2017	Lytte, IV et al.
9,370,364 B2	6/2016	Smith et al.	9,629,626 B2	4/2017	Soltz et al.
9,386,983 B2	7/2016	Swensgard et al.	9,629,629 B2	4/2017	Leimbach et al.
9,386,984 B2	7/2016	Aronhalt et al.	9,629,814 B2	4/2017	Widenhouse et al.
9,386,985 B2	7/2016	Koch, Jr. et al.	9,642,620 B2	5/2017	Baxter, III et al.
9,386,988 B2	7/2016	Baxter, III et al.	9,649,110 B2	5/2017	Parihar et al.
9,393,015 B2	7/2016	Laurent et al.	9,649,111 B2	5/2017	Shelton, IV et al.
9,393,018 B2	7/2016	Wang et al.	9,655,613 B2	5/2017	Schaller
9,398,911 B2	7/2016	Auld	9,655,614 B2	5/2017	Swensgard et al.
9,402,604 B2	8/2016	Williams et al.	9,655,615 B2	5/2017	Knodel et al.
9,402,626 B2	8/2016	Ortiz et al.	9,655,624 B2	5/2017	Shelton, IV et al.
9,402,628 B2	8/2016	Beardsley	9,662,110 B2	5/2017	Huang et al.
9,408,604 B2	8/2016	Shelton, IV et al.	9,662,131 B2	5/2017	Omori et al.
9,408,606 B2	8/2016	Shelton, IV	9,668,729 B2	6/2017	Williams et al.
9,408,622 B2	8/2016	Stulen et al.	9,668,732 B2	6/2017	Patel et al.
9,414,838 B2	8/2016	Shelton, IV et al.	9,675,344 B2	6/2017	Combrowski et al.
9,414,880 B2	8/2016	Monson et al.	9,675,351 B2	6/2017	Hodgkinson et al.
9,421,014 B2	8/2016	Ingmanson et al.	9,675,355 B2	6/2017	Shelton, IV et al.
9,427,223 B2	8/2016	Park et al.	9,675,372 B2	6/2017	Laurent et al.
9,433,411 B2	9/2016	Racenet et al.	9,675,375 B2	6/2017	Houser et al.
9,433,419 B2	9/2016	Gonzalez et al.	9,681,870 B2	6/2017	Baxter, III et al.
9,433,420 B2	9/2016	Hodgkinson	9,681,873 B2	6/2017	Smith et al.
9,439,649 B2	9/2016	Shelton, IV et al.	9,687,230 B2	6/2017	Leimbach et al.
9,439,651 B2	9/2016	Smith et al.	9,687,231 B2	6/2017	Baxter, III et al.
9,445,813 B2	9/2016	Shelton, IV et al.	9,687,232 B2*	6/2017	Shelton, IV A61B 17/07207
9,451,956 B2	9/2016	Balbierz et al.	9,687,236 B2	6/2017	Leimbach et al.
9,451,958 B2	9/2016	Shelton, IV et al.	9,687,237 B2	6/2017	Schmid et al.
9,463,260 B2	10/2016	Stopek	9,690,362 B2	6/2017	Leimbach et al.
9,468,438 B2	10/2016	Baber et al.	9,693,772 B2	7/2017	Ingmanson et al.
9,480,476 B2	11/2016	Aldridge et al.	9,693,777 B2	7/2017	Schellin et al.
9,480,492 B2	11/2016	Aranyi et al.	9,700,309 B2	7/2017	Jaworek et al.
9,486,213 B2	11/2016	Altman et al.	9,700,310 B2	7/2017	Morgan et al.
9,486,214 B2	11/2016	Shelton, IV	9,700,317 B2	7/2017	Aronhalt et al.
9,492,146 B2	11/2016	Kostrzewski et al.	9,700,319 B2	7/2017	Motooka et al.
9,492,167 B2	11/2016	Shelton, IV et al.	9,700,321 B2	7/2017	Shelton, IV et al.
9,492,170 B2	11/2016	Bear et al.	9,706,991 B2	7/2017	Hess et al.
9,498,215 B2	11/2016	Duque et al.	9,707,043 B2	7/2017	Bozung
9,498,219 B2	11/2016	Moore et al.	9,724,091 B2	8/2017	Shelton, IV et al.
D775,336 S	12/2016	Shelton, IV et al.	9,724,092 B2	8/2017	Baxter, III et al.
9,510,827 B2	12/2016	Kostrzewski	9,724,094 B2	8/2017	Baber et al.
9,510,828 B2	12/2016	Yates et al.	9,724,096 B2	8/2017	Thompson et al.
9,510,830 B2	12/2016	Shelton, IV et al.	9,724,098 B2	8/2017	Baxter, III et al.
9,510,846 B2	12/2016	Sholev et al.	9,730,692 B2	8/2017	Shelton, IV et al.
9,517,063 B2	12/2016	Swayze et al.	9,730,695 B2	8/2017	Leimbach et al.
9,517,068 B2	12/2016	Shelton, IV et al.	9,730,697 B2	8/2017	Morgan et al.
9,522,029 B2	12/2016	Yates et al.	9,733,663 B2	8/2017	Leimbach et al.
9,545,258 B2	1/2017	Smith et al.	9,737,301 B2	8/2017	Baber et al.
9,549,732 B2	1/2017	Yates et al.	9,737,302 B2	8/2017	Shelton, IV et al.
9,549,735 B2	1/2017	Shelton, IV et al.	9,737,303 B2	8/2017	Shelton, IV et al.
9,554,794 B2	1/2017	Baber et al.	9,737,365 B2	8/2017	Hegeman et al.
			9,743,928 B2	8/2017	Shelton, IV et al.
			9,743,929 B2	8/2017	Leimbach et al.
			9,750,498 B2	9/2017	Timm et al.
			9,750,499 B2	9/2017	Leimbach et al.

(56)

References Cited

U.S. PATENT DOCUMENTS

9,750,501 B2	9/2017	Shelton, IV et al.	9,895,148 B2	2/2018	Shelton, IV et al.
9,750,502 B2	9/2017	Scirica et al.	9,895,813 B2	2/2018	Blumenkranz et al.
9,757,123 B2	9/2017	Giordano et al.	9,901,342 B2	2/2018	Shelton, IV et al.
9,757,124 B2	9/2017	Schellin et al.	9,901,343 B2	2/2018	Vold et al.
9,757,128 B2	9/2017	Baber et al.	9,907,620 B2	3/2018	Shelton, IV et al.
9,757,130 B2	9/2017	Shelton, IV	9,913,642 B2	3/2018	Leimbach et al.
9,763,662 B2	9/2017	Shelton, IV et al.	9,913,647 B2	3/2018	Weisenburgh, II et al.
9,770,245 B2	9/2017	Swayze et al.	9,913,648 B2	3/2018	Shelton, IV et al.
9,775,608 B2	10/2017	Aronhalt et al.	9,913,694 B2	3/2018	Brisson
9,775,609 B2	10/2017	Shelton, IV et al.	9,918,704 B2	3/2018	Shelton, IV et al.
9,775,613 B2	10/2017	Shelton, IV et al.	9,918,716 B2	3/2018	Baxter, III et al.
9,775,614 B2	10/2017	Shelton, IV et al.	9,918,717 B2	3/2018	Czernik
9,782,169 B2	10/2017	Kimsey et al.	9,924,942 B2	3/2018	Swayze et al.
9,788,834 B2	10/2017	Schmid et al.	9,924,947 B2	3/2018	Shelton, IV et al.
9,788,836 B2	10/2017	Overmyer et al.	9,924,961 B2	3/2018	Shelton, IV et al.
9,795,379 B2	10/2017	Leimbach et al.	9,931,118 B2	4/2018	Shelton, IV et al.
9,795,381 B2	10/2017	Shelton, IV	9,943,309 B2	4/2018	Shelton, IV et al.
9,795,382 B2	10/2017	Shelton, IV	9,943,310 B2	4/2018	Harris et al.
9,795,384 B2	10/2017	Weaner et al.	9,962,158 B2	5/2018	Hall et al.
9,801,626 B2	10/2017	Parihar et al.	9,962,161 B2	5/2018	Scheib et al.
9,801,627 B2	10/2017	Harris et al.	9,968,354 B2	5/2018	Shelton, IV et al.
9,801,628 B2	10/2017	Harris et al.	9,968,355 B2	5/2018	Shelton, IV et al.
9,801,634 B2	10/2017	Shelton, IV et al.	9,968,356 B2	5/2018	Shelton, IV et al.
9,804,618 B2	10/2017	Leimbach et al.	9,968,397 B2	5/2018	Taylor et al.
9,808,244 B2	11/2017	Leimbach et al.	9,974,529 B2	5/2018	Shelton, IV et al.
9,808,246 B2	11/2017	Shelton, IV et al.	9,974,538 B2	5/2018	Baxter, III et al.
9,808,247 B2	11/2017	Shelton, IV et al.	9,980,713 B2	5/2018	Aronhalt et al.
9,808,249 B2	11/2017	Shelton, IV	9,980,729 B2	5/2018	Moore et al.
9,814,460 B2	11/2017	Kimsey et al.	9,987,000 B2	6/2018	Shelton, IV et al.
9,814,462 B2	11/2017	Woodard, Jr. et al.	9,987,006 B2	6/2018	Morgan et al.
9,820,738 B2	11/2017	Lytlye, IV et al.	9,987,011 B2	6/2018	Williams et al.
9,820,741 B2	11/2017	Kostrzewski	9,987,095 B2	6/2018	Chowaniec et al.
9,826,976 B2	11/2017	Parihar et al.	9,987,099 B2	6/2018	Chen et al.
9,826,977 B2	11/2017	Leimbach et al.	9,993,248 B2	6/2018	Shelton, IV et al.
9,826,978 B2	11/2017	Shelton, IV et al.	9,993,258 B2	6/2018	Shelton, IV et al.
9,833,236 B2	12/2017	Shelton, IV et al.	9,999,408 B2	6/2018	Boudreaux et al.
9,833,238 B2	12/2017	Baxter, III et al.	9,999,426 B2	6/2018	Moore et al.
9,833,241 B2	12/2017	Huitema et al.	9,999,431 B2	6/2018	Shelton, IV et al.
9,833,242 B2	12/2017	Baxter, III et al.	10,004,497 B2	6/2018	Overmyer et al.
9,839,420 B2	12/2017	Shelton, IV et al.	10,004,498 B2	6/2018	Morgan et al.
9,839,421 B2	12/2017	Zerkle et al.	10,004,501 B2	6/2018	Shelton, IV et al.
9,839,422 B2	12/2017	Schellin et al.	10,004,505 B2	6/2018	Moore et al.
9,839,423 B2	12/2017	Vendely et al.	D822,206 S	7/2018	Shelton, IV et al.
9,839,425 B2	12/2017	Zergiebel et al.	10,010,322 B2	7/2018	Shelton, IV et al.
9,839,427 B2	12/2017	Swayze et al.	10,010,324 B2	7/2018	Huitema et al.
9,839,428 B2	12/2017	Baxter, III et al.	10,013,049 B2	7/2018	Leimbach et al.
9,839,429 B2	12/2017	Weisenburgh, II et al.	10,016,199 B2	7/2018	Baber et al.
9,839,480 B2	12/2017	Pribanic et al.	10,028,742 B2	7/2018	Shelton, IV et al.
9,844,368 B2	12/2017	Boudreaux et al.	10,028,743 B2	7/2018	Shelton, IV et al.
9,844,369 B2	12/2017	Huitema et al.	10,028,744 B2	7/2018	Shelton, IV et al.
9,844,372 B2	12/2017	Shelton, IV et al.	10,028,761 B2	7/2018	Leimbach et al.
9,844,373 B2	12/2017	Swayze et al.	D826,405 S	8/2018	Shelton, IV et al.
9,844,374 B2	12/2017	Lytlye, IV et al.	10,039,529 B2	8/2018	Kerr et al.
9,844,375 B2	12/2017	Overmyer et al.	10,045,769 B2	8/2018	Aronhalt et al.
9,844,376 B2	12/2017	Baxter, III et al.	10,045,776 B2	8/2018	Shelton, IV et al.
9,844,379 B2	12/2017	Shelton, IV et al.	10,045,779 B2	8/2018	Savage et al.
9,848,873 B2	12/2017	Shelton, IV	10,045,781 B2	8/2018	Cropper et al.
9,848,875 B2	12/2017	Aronhalt et al.	10,052,044 B2	8/2018	Shelton, IV et al.
9,861,359 B2	1/2018	Shelton, IV et al.	10,052,099 B2	8/2018	Morgan et al.
9,861,361 B2	1/2018	Aronhalt et al.	10,052,100 B2	8/2018	Morgan et al.
9,867,612 B2	1/2018	Parihar et al.	10,058,317 B2	8/2018	Fan et al.
9,867,613 B2	1/2018	Marczyk et al.	10,058,327 B2	8/2018	Weisenburgh, II et al.
9,867,618 B2	1/2018	Hall et al.	10,058,963 B2	8/2018	Shelton, IV et al.
9,868,198 B2	1/2018	Nicholas et al.	10,064,621 B2	9/2018	Kerr et al.
9,872,682 B2	1/2018	Hess et al.	10,064,624 B2	9/2018	Shelton, IV et al.
9,872,683 B2	1/2018	Hopkins et al.	10,064,688 B2	9/2018	Shelton, IV et al.
9,872,684 B2	1/2018	Hall et al.	10,070,861 B2	9/2018	Spivey et al.
9,877,721 B2	1/2018	Schellin et al.	10,070,863 B2	9/2018	Swayze et al.
9,883,860 B2	2/2018	Leimbach et al.	10,071,452 B2	9/2018	Shelton, IV et al.
9,883,861 B2	2/2018	Shelton, IV et al.	10,076,325 B2	9/2018	Huang et al.
9,884,456 B2	2/2018	Schellin et al.	10,080,552 B2	9/2018	Nicholas et al.
9,888,919 B2	2/2018	Leimbach et al.	2001/0025183 A1	9/2001	Shahidi
9,888,924 B2	2/2018	Ebersole et al.	2002/0022836 A1	2/2002	Goble et al.
9,889,230 B2	2/2018	Bennett et al.	2002/0029036 A1	3/2002	Goble
9,895,147 B2	2/2018	Shelton, IV	2002/0095175 A1	7/2002	Brock et al.
			2002/0103494 A1	8/2002	Pacey
			2002/0117534 A1	8/2002	Green et al.
			2002/0127265 A1	9/2002	Bowman et al.
			2002/0134811 A1	9/2002	Napier et al.

(56)

References Cited

U.S. PATENT DOCUMENTS

2002/0143340	A1	10/2002	Kaneko	2005/0169974	A1	8/2005	Tenerz et al.
2003/0078647	A1	4/2003	Vallana et al.	2005/0171522	A1	8/2005	Christopherson
2003/0084983	A1	5/2003	Rangachari et al.	2005/0177181	A1	8/2005	Kagan et al.
2003/0093103	A1	5/2003	Malackowski et al.	2005/0182298	A1	8/2005	Ikeda et al.
2003/0096158	A1	5/2003	Takano et al.	2005/0187545	A1	8/2005	Hooven et al.
2003/0139741	A1	7/2003	Goble et al.	2005/0203550	A1	9/2005	Laufer et al.
2003/0153908	A1	8/2003	Goble et al.	2005/0216055	A1	9/2005	Scirica et al.
2003/0163085	A1	8/2003	Tanner et al.	2005/0228224	A1	10/2005	Okada et al.
2003/0181900	A1	9/2003	Long	2005/0240178	A1	10/2005	Morley et al.
2003/0195387	A1	10/2003	Kortenbach et al.	2005/0245965	A1	11/2005	Orban, III et al.
2003/0205029	A1	11/2003	Chapolini et al.	2005/0246881	A1	11/2005	Kelly et al.
2003/0216732	A1	11/2003	Truckai et al.	2005/0256452	A1	11/2005	DeMarchi et al.
2003/0236505	A1	12/2003	Bonadio et al.	2005/0261676	A1	11/2005	Hall et al.
2004/0006335	A1	1/2004	Garrison	2005/0263563	A1	12/2005	Racenet et al.
2004/0006340	A1	1/2004	Latterell et al.	2005/0267455	A1	12/2005	Eggers et al.
2004/0028502	A1	2/2004	Cummins	2005/0283188	A1	12/2005	Loshakove et al.
2004/0030333	A1	2/2004	Goble	2006/0008787	A1	1/2006	Hayman et al.
2004/0034357	A1	2/2004	Beane et al.	2006/0015009	A1	1/2006	Jaffe et al.
2004/0044364	A1	3/2004	DeVries et al.	2006/0020258	A1	1/2006	Strauss et al.
2004/0068161	A1	4/2004	Couvillon	2006/0020336	A1	1/2006	Liddicoat
2004/0068224	A1	4/2004	Couvillon et al.	2006/0025812	A1	2/2006	Shelton
2004/0068307	A1	4/2004	Goble	2006/0041188	A1	2/2006	Dirusso et al.
2004/0070369	A1	4/2004	Sakakibara	2006/0047275	A1	3/2006	Goble
2004/0073222	A1	4/2004	Koseki	2006/0049229	A1	3/2006	Milliman et al.
2004/0078037	A1	4/2004	Batchelor et al.	2006/0052824	A1	3/2006	Ransick et al.
2004/0093024	A1	5/2004	Lousarian et al.	2006/0052825	A1	3/2006	Ransick et al.
2004/0098040	A1	5/2004	Taniguchi et al.	2006/0064086	A1	3/2006	Odom
2004/0101822	A1	5/2004	Wiesner et al.	2006/0079735	A1	4/2006	Martone et al.
2004/0102783	A1	5/2004	Sutterlin et al.	2006/0086032	A1	4/2006	Valencic et al.
2004/0108357	A1	6/2004	Milliman et al.	2006/0087746	A1	4/2006	Lipow
2004/0110439	A1	6/2004	Chaikof et al.	2006/0089535	A1	4/2006	Raz et al.
2004/0115022	A1	6/2004	Albertson et al.	2006/0100649	A1	5/2006	Hart
2004/0116952	A1	6/2004	Sakurai et al.	2006/0180634	A1	8/2006	Shelton et al.
2004/0147909	A1	7/2004	Johnston et al.	2006/0185682	A1	8/2006	Marczyk
2004/0164123	A1	8/2004	Racenet et al.	2006/0201989	A1	9/2006	Ojeda
2004/0167572	A1	8/2004	Roth et al.	2006/0212071	A1	9/2006	Ginn et al.
2004/0181219	A1	9/2004	Goble et al.	2006/0252993	A1	11/2006	Freed et al.
2004/0193189	A1	9/2004	Kortenbach et al.	2006/0289602	A1	12/2006	Wales et al.
2004/0199181	A1	10/2004	Knodel et al.	2006/0291981	A1	12/2006	Viola et al.
2004/0222268	A1	11/2004	Bilotti et al.	2007/0010838	A1	1/2007	Shelton et al.
2004/0225186	A1	11/2004	Horne et al.	2007/0026039	A1	2/2007	Drumheller et al.
2004/0232201	A1	11/2004	Wenchell et al.	2007/0026040	A1	2/2007	Crawley et al.
2004/0236352	A1	11/2004	Wang et al.	2007/0027468	A1	2/2007	Wales et al.
2004/0243147	A1	12/2004	Lipow	2007/0027551	A1	2/2007	Farnsworth et al.
2004/0243151	A1	12/2004	Demmy et al.	2007/0049951	A1	3/2007	Menn
2004/0243163	A1	12/2004	Casiano et al.	2007/0049966	A1	3/2007	Bonadio et al.
2004/0247415	A1	12/2004	Mangone	2007/0051375	A1	3/2007	Milliman
2004/0254566	A1	12/2004	Plicchi et al.	2007/0073341	A1	3/2007	Smith et al.
2004/0254590	A1	12/2004	Hoffman et al.	2007/0078484	A1	4/2007	Talarico et al.
2004/0260315	A1	12/2004	Dell et al.	2007/0084897	A1	4/2007	Shelton et al.
2004/0267310	A1	12/2004	Racenet et al.	2007/0093869	A1	4/2007	Bloom et al.
2005/0010213	A1	1/2005	Stad et al.	2007/0102472	A1	5/2007	Shelton
2005/0032511	A1	2/2005	Malone et al.	2007/0106113	A1	5/2007	Ravo
2005/0033352	A1	2/2005	Zepf et al.	2007/0106317	A1	5/2007	Shelton et al.
2005/0054946	A1	3/2005	Krzyzanowski	2007/0135686	A1	6/2007	Pruitt et al.
2005/0059997	A1	3/2005	Bauman et al.	2007/0135803	A1	6/2007	Belson
2005/0070929	A1	3/2005	Dalessandro et al.	2007/0155010	A1	7/2007	Farnsworth et al.
2005/0075561	A1	4/2005	Golden	2007/0170225	A1	7/2007	Shelton et al.
2005/0085693	A1	4/2005	Belson et al.	2007/0173687	A1	7/2007	Shima et al.
2005/0090817	A1	4/2005	Phan	2007/0173813	A1	7/2007	Odom
2005/0096683	A1	5/2005	Ellins et al.	2007/0175950	A1	8/2007	Shelton et al.
2005/0124855	A1	6/2005	Jaffe et al.	2007/0175951	A1	8/2007	Shelton et al.
2005/0125897	A1	6/2005	Wyslucha et al.	2007/0175955	A1	8/2007	Shelton et al.
2005/0131173	A1	6/2005	McDaniel et al.	2007/0190110	A1	8/2007	Pameijer et al.
2005/0131211	A1	6/2005	Bayley et al.	2007/0191868	A1	8/2007	Theroux et al.
2005/0131390	A1	6/2005	Heinrich et al.	2007/0194079	A1	8/2007	Hueil et al.
2005/0131436	A1	6/2005	Johnston et al.	2007/0194082	A1	8/2007	Morgan et al.
2005/0131457	A1	6/2005	Douglas et al.	2007/0203510	A1	8/2007	Bettuchi
2005/0137454	A1	6/2005	Saadat et al.	2007/0208359	A1	9/2007	Hoffman
2005/0137455	A1	6/2005	Ewers et al.	2007/0213750	A1	9/2007	Weadock
2005/0143759	A1	6/2005	Kelly	2007/0225562	A1	9/2007	Spivey et al.
2005/0143769	A1	6/2005	White et al.	2007/0233163	A1	10/2007	Bombard et al.
2005/0154258	A1	7/2005	Tartaglia et al.	2007/0243227	A1	10/2007	Gertner
2005/0154406	A1	7/2005	Bombard et al.	2007/0244471	A1	10/2007	Malackowski
2005/0165419	A1	7/2005	Sauer et al.	2007/0246505	A1	10/2007	Pace-Florida et al.
				2007/0275035	A1	11/2007	Herman et al.
				2007/0276409	A1	11/2007	Ortiz et al.
				2007/0279011	A1	12/2007	Jones et al.
				2007/0286892	A1	12/2007	Herzberg et al.

(56)

References Cited

U.S. PATENT DOCUMENTS

2008/0003196	A1	1/2008	Jonn et al.	2009/0292283	A1	11/2009	Odom
2008/0015598	A1	1/2008	Prommersberger	2009/0308907	A1	12/2009	Nalagatla et al.
2008/0021278	A1	1/2008	Leonard et al.	2009/0318957	A1	12/2009	Viola et al.
2008/0029570	A1	2/2008	Shelton et al.	2010/0016888	A1	1/2010	Calabrese et al.
2008/0029573	A1	2/2008	Shelton et al.	2010/0023024	A1	1/2010	Zeiner et al.
2008/0029574	A1	2/2008	Shelton et al.	2010/0023052	A1	1/2010	Heinrich et al.
2008/0029575	A1	2/2008	Shelton et al.	2010/0036370	A1	2/2010	Mirel et al.
2008/0030170	A1	2/2008	Dacquay et al.	2010/0069942	A1	3/2010	Shelton, IV
2008/0051833	A1	2/2008	Gramuglia et al.	2010/0076483	A1	3/2010	Imuta
2008/0065153	A1	3/2008	Allard et al.	2010/0076489	A1	3/2010	Stopek et al.
2008/0078802	A1	4/2008	Hess et al.	2010/0100124	A1	4/2010	Calabrese et al.
2008/0082114	A1	4/2008	McKenna et al.	2010/0133316	A1	6/2010	Lizee et al.
2008/0082125	A1	4/2008	Murray et al.	2010/0133317	A1	6/2010	Shelton, IV et al.
2008/0082126	A1	4/2008	Murray et al.	2010/0145146	A1	6/2010	Melder
2008/0085296	A1	4/2008	Powell et al.	2010/0147921	A1	6/2010	Olson
2008/0086078	A1	4/2008	Powell et al.	2010/0147922	A1	6/2010	Olson
2008/0091072	A1	4/2008	Omori et al.	2010/0179022	A1	7/2010	Shirokoshi
2008/0128469	A1	6/2008	Dalessandro et al.	2010/0191262	A1	7/2010	Harris et al.
2008/0129253	A1	6/2008	Shiue et al.	2010/0193566	A1	8/2010	Scheib et al.
2008/0140115	A1	6/2008	Stopek	2010/0204717	A1	8/2010	Knodel
2008/0154299	A1	6/2008	Livneh	2010/0222901	A1	9/2010	Swayze et al.
2008/0169328	A1	7/2008	Shelton	2010/0249497	A1	9/2010	Peine et al.
2008/0169332	A1	7/2008	Shelton et al.	2010/0267662	A1	10/2010	Fielder et al.
2008/0169333	A1	7/2008	Shelton et al.	2010/0274160	A1	10/2010	Yachi et al.
2008/0172087	A1	7/2008	Fuchs et al.	2010/0292540	A1	11/2010	Hess et al.
2008/0183193	A1	7/2008	Omori et al.	2010/0298636	A1	11/2010	Castro et al.
2008/0190989	A1	8/2008	Crews et al.	2010/0312261	A1	12/2010	Suzuki et al.
2008/0197167	A1	8/2008	Viola et al.	2010/0331856	A1	12/2010	Carlson et al.
2008/0200762	A1	8/2008	Stokes et al.	2011/0006101	A1	1/2011	Hall et al.
2008/0200835	A1	8/2008	Monson et al.	2011/0011916	A1	1/2011	Levine
2008/0200933	A1	8/2008	Bakos et al.	2011/0022032	A1	1/2011	Zemlok et al.
2008/0255413	A1	10/2008	Zemlok et al.	2011/0024477	A1	2/2011	Hall
2008/0262654	A1	10/2008	Omori et al.	2011/0024478	A1	2/2011	Shelton, IV
2008/0287944	A1	11/2008	Pearson et al.	2011/0036891	A1	2/2011	Zemlok et al.
2008/0294179	A1	11/2008	Balbierz et al.	2011/0046667	A1	2/2011	Culligan et al.
2008/0296346	A1	12/2008	Shelton, IV et al.	2011/0060363	A1	3/2011	Hess et al.
2008/0297287	A1	12/2008	Shachar et al.	2011/0082538	A1	4/2011	Dahlgren et al.
2008/0308602	A1	12/2008	Timm et al.	2011/0087276	A1	4/2011	Bedi et al.
2008/0308603	A1	12/2008	Shelton et al.	2011/0114697	A1	5/2011	Baxter, III et al.
2008/0315829	A1	12/2008	Jones et al.	2011/0121049	A1	5/2011	Malinouskas et al.
2009/0001121	A1	1/2009	Hess et al.	2011/0125176	A1	5/2011	Yates et al.
2009/0001130	A1	1/2009	Hess et al.	2011/0137340	A1	6/2011	Cummins
2009/0004455	A1	1/2009	Gravagna et al.	2011/0147433	A1	6/2011	Shelton, IV et al.
2009/0005809	A1	1/2009	Hess et al.	2011/0163146	A1	7/2011	Ortiz et al.
2009/0012534	A1	1/2009	Madhani et al.	2011/0174861	A1	7/2011	Shelton, IV et al.
2009/0020958	A1	1/2009	Soul	2011/0192882	A1	8/2011	Hess et al.
2009/0048589	A1	2/2009	Takashino et al.	2011/0275901	A1	11/2011	Shelton, IV
2009/0076506	A1	3/2009	Baker	2011/0276083	A1	11/2011	Shelton, IV et al.
2009/0078736	A1	3/2009	Van Lue	2011/0278343	A1	11/2011	Knodel et al.
2009/0081313	A1	3/2009	Aghion et al.	2011/0290856	A1	12/2011	Shelton, IV et al.
2009/0090763	A1	4/2009	Zemlok et al.	2011/0293690	A1	12/2011	Griffin et al.
2009/0092651	A1	4/2009	Shah et al.	2011/0295295	A1	12/2011	Shelton, IV et al.
2009/0099579	A1	4/2009	Nentwick et al.	2011/0313894	A1	12/2011	Dye et al.
2009/0099876	A1	4/2009	Whitman	2011/0315413	A1	12/2011	Fisher et al.
2009/0119011	A1	5/2009	Kondo et al.	2012/0004636	A1	1/2012	Lo
2009/0143855	A1	6/2009	Weber et al.	2012/0016413	A1	1/2012	Timm et al.
2009/0149871	A9	6/2009	Kagan et al.	2012/0029272	A1	2/2012	Shelton, IV et al.
2009/0171147	A1	7/2009	Lee et al.	2012/0074200	A1	3/2012	Schmid et al.
2009/0177201	A1	7/2009	Soltz et al.	2012/0080336	A1	4/2012	Shelton, IV et al.
2009/0177226	A1	7/2009	Reinprecht et al.	2012/0080340	A1	4/2012	Shelton, IV et al.
2009/0188964	A1	7/2009	Orlov	2012/0080344	A1	4/2012	Shelton, IV
2009/0198272	A1	8/2009	Kerver et al.	2012/0080478	A1	4/2012	Morgan et al.
2009/0204108	A1	8/2009	Steffen	2012/0080497	A1	4/2012	White et al.
2009/0206125	A1	8/2009	Huitema et al.	2012/0080498	A1	4/2012	Shelton, IV et al.
2009/0206126	A1	8/2009	Huitema et al.	2012/0125792	A1	5/2012	Cassivi
2009/0206131	A1	8/2009	Weisenburgh, II et al.	2012/0130421	A1	5/2012	Hafez et al.
2009/0206133	A1	8/2009	Morgan et al.	2012/0175398	A1	7/2012	Sandborn et al.
2009/0206137	A1	8/2009	Hall et al.	2012/0234895	A1	9/2012	O'Connor et al.
2009/0206139	A1	8/2009	Hall et al.	2012/0234897	A1	9/2012	Shelton, IV et al.
2009/0206141	A1	8/2009	Huitema et al.	2012/0241493	A1	9/2012	Baxter, III et al.
2009/0206142	A1	8/2009	Huitema et al.	2012/0248169	A1	10/2012	Widenhouse et al.
2009/0242610	A1	10/2009	Shelton, IV et al.	2012/0283707	A1	11/2012	Giordano et al.
2009/0247901	A1	10/2009	Zimmer	2012/0289979	A1	11/2012	Eskaros et al.
2009/0255974	A1	10/2009	Viola	2012/0292367	A1	11/2012	Morgan et al.
2009/0270895	A1	10/2009	Churchill et al.	2012/0298722	A1	11/2012	Hess et al.
				2013/0012983	A1	1/2013	Kleyman
				2013/0020375	A1	1/2013	Shelton, IV et al.
				2013/0020376	A1	1/2013	Shelton, IV et al.
				2013/0023861	A1	1/2013	Shelton, IV et al.

(56)

References Cited

U.S. PATENT DOCUMENTS

2013/0026208 A1	1/2013	Shelton, IV et al.	2015/0060520 A1	3/2015	Shelton, IV et al.
2013/0026210 A1	1/2013	Shelton, IV et al.	2015/0060521 A1	3/2015	Weisenburgh, II et al.
2013/0030462 A1	1/2013	Keating et al.	2015/0076207 A1	3/2015	Boudreaux et al.
2013/0087597 A1	4/2013	Shelton, IV et al.	2015/0076208 A1	3/2015	Shelton, IV
2013/0087603 A1	4/2013	Viola	2015/0076209 A1	3/2015	Shelton, IV et al.
2013/0098970 A1	4/2013	Racenet et al.	2015/0076210 A1	3/2015	Shelton, IV et al.
2013/0116669 A1	5/2013	Shelton, IV et al.	2015/0076212 A1	3/2015	Shelton, IV
2013/0131651 A1	5/2013	Strobl et al.	2015/0080868 A1	3/2015	Kerr
2013/0153636 A1	6/2013	Shelton, IV et al.	2015/0083781 A1	3/2015	Giordano et al.
2013/0153641 A1	6/2013	Shelton, IV et al.	2015/0083782 A1	3/2015	Scheib et al.
2013/0172929 A1	7/2013	Hess et al.	2015/0090760 A1	4/2015	Giordano et al.
2013/0175317 A1	7/2013	Yates et al.	2015/0090761 A1	4/2015	Giordano et al.
2013/0181033 A1	7/2013	Shelton, IV et al.	2015/0090762 A1	4/2015	Giordano et al.
2013/0181034 A1	7/2013	Shelton, IV et al.	2015/0090763 A1	4/2015	Murray et al.
2013/0214025 A1	8/2013	Zemlok et al.	2015/0108199 A1	4/2015	Shelton, IV et al.
2013/0214030 A1	8/2013	Aronhalt et al.	2015/0144679 A1*	5/2015	Scirica A61B 17/07207 227/180.1
2013/0233906 A1	9/2013	Hess et al.	2015/0173744 A1	6/2015	Shelton, IV et al.
2013/0256373 A1	10/2013	Schmid et al.	2015/0173749 A1	6/2015	Shelton, IV et al.
2013/0256379 A1	10/2013	Schmid et al.	2015/0173756 A1	6/2015	Baxter, III et al.
2013/0256380 A1	10/2013	Schmid et al.	2015/0173789 A1	6/2015	Baxter, III et al.
2013/0261661 A1	10/2013	Piraka	2015/0182220 A1	7/2015	Yates et al.
2013/0270322 A1	10/2013	Scheib et al.	2015/0196295 A1	7/2015	Shelton, IV et al.
2013/0317305 A1	11/2013	Stevenson et al.	2015/0196296 A1	7/2015	Swayze et al.
2013/0324981 A1	12/2013	Smith et al.	2015/0196299 A1	7/2015	Swayze et al.
2013/0324982 A1	12/2013	Smith et al.	2015/0196347 A1	7/2015	Yates et al.
2013/0334280 A1	12/2013	Krehel et al.	2015/0196348 A1	7/2015	Yates et al.
2013/0334283 A1	12/2013	Swayze et al.	2015/0201932 A1	7/2015	Swayze et al.
2013/0334284 A1	12/2013	Swayze et al.	2015/0201936 A1	7/2015	Swayze et al.
2013/0334285 A1	12/2013	Swayze et al.	2015/0201937 A1	7/2015	Swayze et al.
2013/0341374 A1	12/2013	Shelton, IV et al.	2015/0201938 A1	7/2015	Swayze et al.
2014/0001231 A1	1/2014	Shelton, IV et al.	2015/0201939 A1	7/2015	Swayze et al.
2014/0001234 A1	1/2014	Shelton, IV et al.	2015/0201940 A1	7/2015	Swayze et al.
2014/0005640 A1	1/2014	Shelton, IV et al.	2015/0201941 A1	7/2015	Swayze et al.
2014/0005678 A1	1/2014	Shelton, IV et al.	2015/0209031 A1	7/2015	Shelton, IV et al.
2014/0005702 A1	1/2014	Timm et al.	2015/0231409 A1	8/2015	Racenet et al.
2014/0005718 A1	1/2014	Shelton, IV et al.	2015/0265276 A1	9/2015	Huitema et al.
2014/0014705 A1	1/2014	Baxter, III	2015/0265357 A1	9/2015	Shelton, IV et al.
2014/0018832 A1	1/2014	Shelton, IV	2015/0272557 A1	10/2015	Overmyer et al.
2014/0048580 A1	2/2014	Merchant et al.	2015/0272571 A1	10/2015	Leimbach et al.
2014/0103098 A1	4/2014	Choi et al.	2015/0272580 A1	10/2015	Leimbach et al.
2014/0107640 A1	4/2014	Yates et al.	2015/0272582 A1	10/2015	Leimbach et al.
2014/0151433 A1	6/2014	Shelton, IV et al.	2015/0280384 A1	10/2015	Leimbach et al.
2014/0158747 A1	6/2014	Measamer et al.	2015/0282810 A1	10/2015	Shelton, IV et al.
2014/0166724 A1	6/2014	Schellin et al.	2015/0289873 A1	10/2015	Shelton, IV et al.
2014/0166725 A1	6/2014	Schellin et al.	2015/0289874 A1	10/2015	Leimbach et al.
2014/0166726 A1	6/2014	Schellin et al.	2015/0297210 A1	10/2015	Widenhouse et al.
2014/0171966 A1	6/2014	Giordano et al.	2015/0297219 A1	10/2015	Shelton, IV et al.
2014/0175152 A1	6/2014	Hess et al.	2015/0297222 A1*	10/2015	Huitema A61B 17/068 227/176.1
2014/0224857 A1	8/2014	Schmid	2015/0297223 A1	10/2015	Huitema et al.
2014/0243865 A1	8/2014	Swayze et al.	2015/0297225 A1	10/2015	Huitema et al.
2014/0246475 A1	9/2014	Hall et al.	2015/0297228 A1	10/2015	Huitema et al.
2014/0248167 A1	9/2014	Sugimoto et al.	2015/0297229 A1	10/2015	Schellin et al.
2014/0249557 A1	9/2014	Koch, Jr. et al.	2015/0297232 A1	10/2015	Huitema et al.
2014/0263541 A1	9/2014	Leimbach et al.	2015/0297233 A1	10/2015	Huitema et al.
2014/0263552 A1	9/2014	Hall et al.	2015/0297234 A1	10/2015	Schellin et al.
2014/0263554 A1	9/2014	Leimbach et al.	2015/0297235 A1	10/2015	Harris et al.
2014/0263558 A1	9/2014	Hausen et al.	2015/0297236 A1	10/2015	Harris et al.
2014/0284371 A1	9/2014	Morgan et al.	2015/0313594 A1	11/2015	Shelton, IV et al.
2014/0291378 A1	10/2014	Shelton, IV et al.	2015/0327864 A1	11/2015	Hodgkinson et al.
2014/0291379 A1	10/2014	Schellin et al.	2015/0335328 A1	11/2015	Shelton, IV et al.
2014/0291383 A1	10/2014	Spivey et al.	2015/0342603 A1	12/2015	Zergiebel et al.
2014/0299648 A1	10/2014	Shelton, IV et al.	2015/0342607 A1	12/2015	Shelton, IV et al.
2014/0303645 A1	10/2014	Morgan et al.	2015/0374368 A1	12/2015	Swayze et al.
2014/0305990 A1	10/2014	Shelton, IV et al.	2015/0374369 A1	12/2015	Yates et al.
2014/0305991 A1	10/2014	Parihar et al.	2015/0374374 A1	12/2015	Shelton, IV et al.
2014/0309666 A1	10/2014	Shelton, IV et al.	2015/0374375 A1	12/2015	Shelton, IV et al.
2014/0330161 A1	11/2014	Swayze et al.	2015/0374376 A1	12/2015	Shelton, IV
2015/0008248 A1	1/2015	Giordano et al.	2015/0374377 A1	12/2015	Shelton, IV
2015/0053737 A1	2/2015	Leimbach et al.	2015/0374378 A1	12/2015	Giordano et al.
2015/0053742 A1	2/2015	Shelton, IV et al.	2015/0374379 A1	12/2015	Shelton, IV
2015/0053743 A1	2/2015	Yates et al.	2016/0000430 A1	1/2016	Ming et al.
2015/0053746 A1	2/2015	Shelton, IV et al.	2016/0000431 A1	1/2016	Giordano et al.
2015/0053748 A1	2/2015	Yates et al.	2016/0000437 A1	1/2016	Giordano et al.
2015/0060518 A1	3/2015	Shelton, IV et al.	2016/0000438 A1	1/2016	Swayze et al.
2015/0060519 A1	3/2015	Shelton, IV et al.	2016/0000442 A1	1/2016	Shelton, IV
			2016/0000452 A1	1/2016	Yates et al.
			2016/0000453 A1	1/2016	Yates et al.

(56)

References Cited

U.S. PATENT DOCUMENTS

2016/0000513 A1 1/2016 Shelton, IV et al.
 2016/0007992 A1 1/2016 Yates et al.
 2016/0008023 A1 1/2016 Yates et al.
 2016/0015391 A1 1/2016 Shelton, IV et al.
 2016/0051257 A1 2/2016 Shelton, IV et al.
 2016/0058443 A1 3/2016 Yates et al.
 2016/0066911 A1 3/2016 Baber et al.
 2016/0066912 A1 3/2016 Baber et al.
 2016/0066913 A1 3/2016 Swayze et al.
 2016/0074040 A1 3/2016 Widenhouse et al.
 2016/0089137 A1 3/2016 Hess et al.
 2016/0089142 A1 3/2016 Harris et al.
 2016/0089146 A1 3/2016 Harris et al.
 2016/0089147 A1 3/2016 Harris et al.
 2016/0089149 A1 3/2016 Harris et al.
 2016/0106426 A1* 4/2016 Shelton, IV A61B 17/07207
 227/176.1
 2016/0106427 A1* 4/2016 Shelton, IV A61B 17/07207
 227/180.1
 2016/0106431 A1 4/2016 Shelton, IV et al.
 2016/0113653 A1 4/2016 Zingman
 2016/0120544 A1 5/2016 Shelton, IV et al.
 2016/0120545 A1 5/2016 Shelton, IV et al.
 2016/0166256 A1 6/2016 Baxter, III et al.
 2016/0174969 A1 6/2016 Kerr et al.
 2016/0174971 A1 6/2016 Baxter, III et al.
 2016/0174972 A1 6/2016 Shelton, IV et al.
 2016/0174974 A1 6/2016 Schmid et al.
 2016/0174976 A1 6/2016 Morgan et al.
 2016/0174984 A1 6/2016 Smith et al.
 2016/0174985 A1 6/2016 Baxter, III et al.
 2016/0183939 A1 6/2016 Shelton, IV et al.
 2016/0183943 A1 6/2016 Shelton, IV
 2016/0183944 A1 6/2016 Swensgard et al.
 2016/0183945 A1 6/2016 Shelton, IV et al.
 2016/0192916 A1 7/2016 Shelton, IV et al.
 2016/0192917 A1 7/2016 Shelton, IV et al.
 2016/0192918 A1 7/2016 Shelton, IV et al.
 2016/0192929 A1 7/2016 Schmid et al.
 2016/0192933 A1 7/2016 Shelton, IV
 2016/0192936 A1 7/2016 Leimbach et al.
 2016/0192996 A1 7/2016 Spivey et al.
 2016/0199059 A1 7/2016 Shelton, IV et al.
 2016/0199061 A1 7/2016 Shelton, IV et al.
 2016/0199063 A1 7/2016 Mandakolathur Vasudevan et al.
 2016/0199064 A1 7/2016 Shelton, IV et al.
 2016/0199089 A1 7/2016 Hess et al.
 2016/0199956 A1 7/2016 Shelton, IV et al.
 2016/0206310 A1 7/2016 Shelton, IV
 2016/0206314 A1 7/2016 Scheib et al.
 2016/0220248 A1 8/2016 Timm et al.
 2016/0220249 A1 8/2016 Shelton, IV et al.
 2016/0220266 A1 8/2016 Shelton, IV et al.
 2016/0220268 A1 8/2016 Shelton, IV et al.
 2016/0235403 A1 8/2016 Shelton, IV et al.
 2016/0235404 A1 8/2016 Shelton, IV
 2016/0235405 A1 8/2016 Shelton, IV et al.
 2016/0235406 A1 8/2016 Shelton, IV et al.
 2016/0235408 A1 8/2016 Shelton, IV et al.
 2016/0235409 A1 8/2016 Shelton, IV et al.
 2016/0235494 A1 8/2016 Shelton, IV et al.
 2016/0242775 A1 8/2016 Shelton, IV et al.
 2016/0242776 A1 8/2016 Shelton, IV et al.
 2016/0242777 A1 8/2016 Shelton, IV et al.
 2016/0242781 A1 8/2016 Shelton, IV et al.
 2016/0242782 A1 8/2016 Shelton, IV et al.
 2016/0242783 A1 8/2016 Shelton, IV et al.
 2016/0249909 A1 9/2016 Shelton, IV et al.
 2016/0249910 A1 9/2016 Shelton, IV et al.
 2016/0249911 A1 9/2016 Timm et al.
 2016/0249915 A1 9/2016 Beckman et al.
 2016/0249916 A1 9/2016 Shelton, IV et al.
 2016/0249917 A1 9/2016 Beckman et al.
 2016/0249918 A1 9/2016 Shelton, IV et al.
 2016/0249922 A1 9/2016 Morgan et al.

2016/0249927 A1 9/2016 Beckman et al.
 2016/0256071 A1 9/2016 Shelton, IV et al.
 2016/0256154 A1 9/2016 Shelton, IV et al.
 2016/0256156 A1 9/2016 Shelton, IV et al.
 2016/0256160 A1 9/2016 Shelton, IV et al.
 2016/0256161 A1 9/2016 Overmyer et al.
 2016/0256185 A1 9/2016 Shelton, IV et al.
 2016/0256229 A1 9/2016 Morgan et al.
 2016/0262745 A1 9/2016 Morgan et al.
 2016/0262746 A1 9/2016 Shelton, IV et al.
 2016/0270780 A1 9/2016 Hall et al.
 2016/0270789 A1* 9/2016 Gupta A61B 17/07207
 2016/0287249 A1 10/2016 Alexander, III et al.
 2016/0287250 A1 10/2016 Shelton, IV et al.
 2016/0287251 A1 10/2016 Shelton, IV et al.
 2016/0287253 A1 10/2016 Shelton, IV et al.
 2016/0338702 A1* 11/2016 Ehrenfels A61B 17/07207
 2016/0367255 A1 12/2016 Wise et al.
 2017/0027571 A1 2/2017 Nalagatla et al.
 2017/0027572 A1 2/2017 Nalagatla et al.
 2017/0027573 A1 2/2017 Nalagatla et al.
 2017/0027574 A1 2/2017 Nalagatla et al.
 2017/0055996 A1* 3/2017 Baxter, III A61B 17/105
 2017/0055997 A1* 3/2017 Swayze A61B 17/07207
 2017/0055998 A1 3/2017 Baxter, III et al.
 2017/0055999 A1 3/2017 Baxter, III et al.
 2017/0056000 A1 3/2017 Nalagatla et al.
 2017/0056001 A1 3/2017 Shelton, IV et al.
 2017/0056002 A1 3/2017 Nalagatla et al.
 2017/0056004 A1 3/2017 Shelton, IV et al.
 2017/0056005 A1 3/2017 Shelton, IV et al.
 2017/0056006 A1 3/2017 Shelton, IV et al.
 2017/0056007 A1 3/2017 Eckert et al.
 2017/0056008 A1 3/2017 Shelton, IV et al.
 2017/0056011 A1 3/2017 Harris et al.
 2017/0056012 A1 3/2017 Harris et al.
 2017/0056013 A1 3/2017 Harris et al.
 2017/0056014 A1 3/2017 Harris et al.
 2017/0056015 A1 3/2017 Harris et al.
 2017/0095250 A1* 4/2017 Kostrzewski A61B 17/072
 2017/0231633 A1* 8/2017 Marczyk A61B 17/068
 227/175.2
 2017/0245856 A1 8/2017 Baxter, III et al.
 2017/0245857 A1 8/2017 Shelton, IV et al.
 2017/0367695 A1 12/2017 Shelton, IV et al.
 2017/0367696 A1 12/2017 Shelton, IV et al.
 2017/0367697 A1 12/2017 Shelton, IV et al.
 2017/0367698 A1 12/2017 Shelton, IV et al.
 2017/0367699 A1 12/2017 Shelton, IV et al.
 2018/0103948 A1 4/2018 Baxter, III et al.
 2018/0110513 A1 4/2018 Baxter, III et al.
 2018/0110517 A1 4/2018 Baxter, III et al.
 2018/0168585 A1 6/2018 Shelton, IV et al.
 2018/0168586 A1 6/2018 Shelton, IV et al.
 2018/0168600 A1* 6/2018 Shelton, IV A61B 17/07207
 2018/0168617 A1 6/2018 Shelton, IV et al.
 2018/0168643 A1 6/2018 Shelton, IV et al.
 2018/0168647 A1 6/2018 Shelton, IV et al.
 2018/0168648 A1 6/2018 Shelton, IV et al.
 2018/0168650 A1 6/2018 Shelton, IV et al.

FOREIGN PATENT DOCUMENTS

AU 2011218702 B2 6/2013
 AU 2012200178 B2 7/2013
 CA 2458946 A1 3/2003
 CA 2477181 A1 4/2004
 CA 2512960 A1 1/2006
 CA 2514274 A1 1/2006
 CA 2639177 A1 2/2009
 CA 2795323 A1 5/2014
 CN 1163558 A 10/1997
 CN 2488482 Y 5/2002
 CN 1523725 A 8/2004
 CN 1545154 A 11/2004
 CN 1634601 A 7/2005
 CN 2716900 Y 8/2005
 CN 2738962 Y 11/2005
 CN 1726874 A 2/2006

(56)

References Cited

FOREIGN PATENT DOCUMENTS

CN	1868411	A	11/2006	EP	0261230	B1	11/1993
CN	1915180	A	2/2007	EP	0324636	B1	3/1994
CN	2868212	Y	2/2007	EP	0591946	A1	4/1994
CN	1960679	A	5/2007	EP	0593920	A1	4/1994
CN	101011286	A	8/2007	EP	0594148	A1	4/1994
CN	101095621	A	1/2008	EP	0427949	B1	6/1994
CN	101111196	A	1/2008	EP	0523174	B1	6/1994
CN	101137402	A	3/2008	EP	0600182	A2	6/1994
CN	101507620	A	8/2009	EP	0310431	B1	11/1994
CN	101507622	A	8/2009	EP	0375302	B1	11/1994
CN	101507623	A	8/2009	EP	0376562	B1	11/1994
CN	101507625	A	8/2009	EP	0630612	A1	12/1994
CN	101507628	A	8/2009	EP	0630614	A1	12/1994
CN	101675898	A	3/2010	EP	0634144	A1	1/1995
CN	101683280	A	3/2010	EP	0639349	A2	2/1995
CN	101028205	B	1/2011	EP	0646356	A2	4/1995
CN	101934098	A	1/2011	EP	0646357	A1	4/1995
CN	201949071	U	8/2011	EP	0505036	B1	5/1995
CN	101336835	B	9/2011	EP	0653189	A2	5/1995
CN	102188270	A	9/2011	EP	0669104	A1	8/1995
CN	101779977	B	12/2011	EP	0387980	B1	10/1995
CN	101534723	B	1/2012	EP	0511470	B1	10/1995
CN	101310680	B	4/2012	EP	0674876	A2	10/1995
CN	202397539	U	8/2012	EP	0676173	B1	10/1995
CN	101317782	B	10/2012	EP	0679367	A2	11/1995
CN	101541251	A	11/2012	EP	0392547	B1	12/1995
CN	101507633	B	2/2013	EP	0685204	A1	12/1995
CN	101023879	B	3/2013	EP	0364216	B1	1/1996
CN	101327137	B	6/2013	EP	0699418	A1	3/1996
CN	101401736	B	6/2013	EP	0702937	A1	3/1996
CN	202982106	U	6/2013	EP	0488768	B1	4/1996
CN	101332110	B	7/2013	EP	0705571	A1	4/1996
CN	101683281	B	1/2014	EP	0528478	B1	5/1996
CN	103648408	A	3/2014	EP	0711611	A2	5/1996
CN	203777011	U	8/2014	EP	0541987	B1	7/1996
DE	273689	C	5/1914	EP	0667119	B1	7/1996
DE	1775926	A	1/1972	EP	0737446	A1	10/1996
DE	3036217	A1	4/1982	EP	0741996	B1	11/1996
DE	3212828	A1	11/1982	EP	0748614	A1	12/1996
DE	3210466	A1	9/1983	EP	0708618	B1	3/1997
DE	3709067	A1	9/1988	EP	0770355	A1	5/1997
DE	4228909	A1	3/1994	EP	0503662	B1	6/1997
DE	9412228	U1	9/1994	EP	0447121	B1	7/1997
DE	19509116	A1	9/1996	EP	0621009	B1	7/1997
DE	19707373	C1	2/1998	EP	0625077	B1	7/1997
DE	19851291	A1	1/2000	EP	0633749	B1	8/1997
DE	19924311	A1	11/2000	EP	0710090	B1	8/1997
DE	69328576	T2	1/2001	EP	0578425	B1	9/1997
DE	20016423	U1	2/2001	EP	0623312	B1	9/1997
DE	10052679	A1	5/2001	EP	0621006	B1	10/1997
DE	20112837	U1	10/2001	EP	0625335	B1	11/1997
DE	20121753	U1	4/2003	EP	0552423	B1	1/1998
DE	10314827	B3	4/2004	EP	0592244	B1	1/1998
DE	202004012389	U1	9/2004	EP	0648476	B1	1/1998
DE	10314072	A1	10/2004	EP	0649290	B1	3/1998
DE	202007003114	U1	6/2007	EP	0598618	B1	9/1998
EP	0000756	A1	2/1979	EP	0678007	B1	9/1998
EP	0122046	A1	10/1984	EP	0869104	A1	10/1998
EP	0070230	B1	4/1985	EP	0603472	B1	11/1998
EP	0156774	A2	10/1985	EP	0605351	B1	11/1998
EP	0050554	B1	1/1986	EP	0878169	A1	11/1998
EP	0033548	B1	5/1986	EP	0879742	A1	11/1998
EP	0077262	B1	8/1986	EP	0695144	B1	12/1998
EP	0129442	B1	11/1987	EP	0722296	B1	12/1998
EP	0276104	A2	7/1988	EP	0760230	B1	2/1999
EP	0178940	B1	1/1991	EP	0623316	B1	3/1999
EP	0178941	B1	1/1991	EP	0650701	B1	3/1999
EP	0169044	B1	6/1991	EP	0650701	B1	3/1999
EP	0248844	B1	1/1993	EP	0537572	B1	6/1999
EP	0539762	A1	5/1993	EP	0923907	A1	6/1999
EP	0545029	A1	6/1993	EP	0640317	B1	9/1999
EP	0548998	A1	6/1993	EP	0843906	B1	3/2000
EP	0379721	B1	9/1993	EP	0552050	B1	5/2000
EP	0277959	B1	10/1993	EP	0833592	B1	5/2000
EP	0233940	B1	11/1993	EP	0795298	B1	6/2000
				EP	0832605	B1	6/2000
				EP	0484677	B2	7/2000
				EP	0830094	B1	9/2000
				EP	1034747	A1	9/2000
				EP	1034748	A1	9/2000

(56)

References Cited

FOREIGN PATENT DOCUMENTS

EP	0694290	B1	11/2000	EP	0906764	B1	12/2005
EP	1050278	A1	11/2000	EP	1330989	B1	12/2005
EP	1053719	A1	11/2000	EP	0771176	B2	1/2006
EP	1053720	A1	11/2000	EP	1621138	A2	2/2006
EP	1055399	A1	11/2000	EP	1621139	A2	2/2006
EP	1055400	A1	11/2000	EP	1621141	A2	2/2006
EP	1058177	A1	12/2000	EP	1621143	A2	2/2006
EP	1080694	A1	3/2001	EP	1621145	A2	2/2006
EP	1090592	A1	4/2001	EP	1621151	A2	2/2006
EP	1095627	A1	5/2001	EP	1034746	B1	3/2006
EP	0806914	B1	9/2001	EP	1201196	B1	3/2006
EP	0768840	B1	12/2001	EP	1632191	A2	3/2006
EP	0908152	B1	1/2002	EP	1647231	A1	4/2006
EP	0717959	B1	2/2002	EP	1065981	B1	5/2006
EP	0872213	B1	5/2002	EP	1082944	B1	5/2006
EP	0862386	B1	6/2002	EP	1230899	B1	5/2006
EP	0949886	B1	9/2002	EP	1652481	A2	5/2006
EP	1238634	A2	9/2002	EP	1382303	B1	6/2006
EP	0858295	B1	12/2002	EP	1253866	B1	7/2006
EP	0656188	B1	1/2003	EP	1032318	B1	8/2006
EP	0717960	B1	2/2003	EP	1045672	B1	8/2006
EP	1284120	A1	2/2003	EP	1617768	B1	8/2006
EP	1287788	A1	3/2003	EP	1693015	A2	8/2006
EP	0717966	B1	4/2003	EP	1400214	B1	9/2006
EP	0869742	B1	5/2003	EP	1702567	A2	9/2006
EP	0829235	B1	6/2003	EP	1129665	B1	11/2006
EP	0887046	B1	7/2003	EP	1400206	B1	11/2006
EP	1323384	A2	7/2003	EP	1721568	A1	11/2006
EP	0852480	B1	8/2003	EP	1256317	B1	12/2006
EP	0891154	B1	9/2003	EP	1285633	B1	12/2006
EP	0813843	B1	10/2003	EP	1728473	A1	12/2006
EP	0873089	B1	10/2003	EP	1736105	A1	12/2006
EP	0856326	B1	11/2003	EP	1011494	B1	1/2007
EP	1374788	A1	1/2004	EP	1479346	B1	1/2007
EP	0814712	B1	2/2004	EP	1484024	B1	1/2007
EP	1402837	A1	3/2004	EP	1749485	A1	2/2007
EP	0705570	B1	4/2004	EP	1754445	A2	2/2007
EP	0959784	B1	4/2004	EP	1759812	A1	3/2007
EP	1407719	A2	4/2004	EP	1767157	A1	3/2007
EP	1411626	A2	4/2004	EP	1767163	A1	3/2007
EP	1086713	B1	5/2004	EP	1563792	B1	4/2007
EP	0996378	B1	6/2004	EP	1769756	A1	4/2007
EP	1426012	A1	6/2004	EP	1769758	A1	4/2007
EP	0833593	B2	7/2004	EP	1581128	B1	5/2007
EP	1442694	A1	8/2004	EP	1780825	A1	5/2007
EP	0888749	B1	9/2004	EP	1785097	A2	5/2007
EP	0959786	B1	9/2004	EP	1790293	A2	5/2007
EP	1453432	A2	9/2004	EP	1790294	A1	5/2007
EP	1459695	A1	9/2004	EP	1563793	B1	6/2007
EP	1254636	B1	10/2004	EP	1800610	A1	6/2007
EP	1473819	A1	11/2004	EP	1300117	B1	8/2007
EP	1477119	A1	11/2004	EP	1813199	A1	8/2007
EP	1479345	A1	11/2004	EP	1813200	A2	8/2007
EP	1479347	A1	11/2004	EP	1813201	A1	8/2007
EP	1479348	A1	11/2004	EP	1813202	A1	8/2007
EP	0754437	B2	12/2004	EP	1813203	A2	8/2007
EP	1025807	B1	12/2004	EP	1813207	A1	8/2007
EP	1001710	B1	1/2005	EP	1813209	A1	8/2007
EP	1496805	A2	1/2005	EP	1815950	A1	8/2007
EP	1256318	B1	2/2005	EP	1330991	B1	9/2007
EP	1520521	A1	4/2005	EP	1837041	A1	9/2007
EP	1520522	A1	4/2005	EP	0922435	B1	10/2007
EP	1520523	A1	4/2005	EP	1487359	B1	10/2007
EP	1520525	A1	4/2005	EP	1599146	B1	10/2007
EP	1522264	A1	4/2005	EP	1839596	A1	10/2007
EP	1523942	A2	4/2005	EP	1679096	B1	11/2007
EP	1550408	A1	7/2005	EP	1857057	A2	11/2007
EP	1557129	A1	7/2005	EP	1402821	B1	12/2007
EP	1064883	B1	8/2005	EP	1872727	A1	1/2008
EP	1067876	B1	8/2005	EP	1550410	B1	2/2008
EP	0870473	B1	9/2005	EP	1671593	B1	2/2008
EP	1157666	B1	9/2005	EP	1897502	A1	3/2008
EP	0880338	B1	10/2005	EP	1611856	B1	4/2008
EP	1158917	B1	11/2005	EP	1908417	A2	4/2008
EP	1344498	B1	11/2005	EP	1917929	A1	5/2008
				EP	1330201	B1	6/2008
				EP	1702568	B1	7/2008
				EP	1943955	A2	7/2008
				EP	1943957	A2	7/2008

(56)

References Cited

FOREIGN PATENT DOCUMENTS

EP	1943959	A1	7/2008	EP	1702570	B1	10/2010
EP	1943962	A2	7/2008	EP	1785098	B1	10/2010
EP	1943964	A1	7/2008	EP	2005896	B1	10/2010
EP	1943976	A2	7/2008	EP	2030578	B1	11/2010
EP	1593337	B1	8/2008	EP	2036505	B1	11/2010
EP	1970014	A1	9/2008	EP	2245993	A2	11/2010
EP	1974678	A2	10/2008	EP	2253280	A1	11/2010
EP	1980213	A2	10/2008	EP	1627605	B1	12/2010
EP	1980214	A2	10/2008	EP	2027811	B1	12/2010
EP	1759645	B1	11/2008	EP	2130498	B1	12/2010
EP	1987780	A2	11/2008	EP	2263568	A2	12/2010
EP	1990014	A2	11/2008	EP	1994890	B1	1/2011
EP	1552795	B1	12/2008	EP	2005900	B1	1/2011
EP	1693008	B1	12/2008	EP	2283780	A2	2/2011
EP	1759640	B1	12/2008	EP	2286738	A2	2/2011
EP	1997439	A2	12/2008	EP	1690502	B1	3/2011
EP	2000101	A2	12/2008	EP	1884201	B1	3/2011
EP	2000102	A2	12/2008	EP	2292153	A1	3/2011
EP	2005894	A2	12/2008	EP	1769755	B1	4/2011
EP	2005897	A2	12/2008	EP	2090240	B1	4/2011
EP	2005901	A1	12/2008	EP	2305135	A1	4/2011
EP	2008595	A2	12/2008	EP	2308388	A1	4/2011
EP	1736104	B1	3/2009	EP	2314254	A2	4/2011
EP	1749486	B1	3/2009	EP	2316345	A1	5/2011
EP	1782743	B1	3/2009	EP	2316366	A2	5/2011
EP	2039302	A2	3/2009	EP	1813205	B1	6/2011
EP	2039308	A2	3/2009	EP	2090243	B1	6/2011
EP	2039316	A2	3/2009	EP	2329773	A1	6/2011
EP	1721576	B1	4/2009	EP	2090239	B1	7/2011
EP	1733686	B1	4/2009	EP	2340771	A2	7/2011
EP	2044890	A1	4/2009	EP	1728475	B1	8/2011
EP	2055243	A2	5/2009	EP	2353545	A1	8/2011
EP	1550409	B1	6/2009	EP	2361562	A1	8/2011
EP	1550413	B1	6/2009	EP	1936253	B1	10/2011
EP	1719461	B1	6/2009	EP	1836986	B1	11/2011
EP	1834594	B1	6/2009	EP	1908414	B1	11/2011
EP	1709911	B1	7/2009	EP	2153781	B1	11/2011
EP	2077093	A2	7/2009	EP	2389928	A2	11/2011
EP	1745748	B1	8/2009	EP	1847225	B1	12/2011
EP	2090231	A1	8/2009	EP	2397079	A1	12/2011
EP	2090237	A1	8/2009	EP	2399538	A2	12/2011
EP	2090241	A1	8/2009	EP	1785102	B1	1/2012
EP	2090245	A1	8/2009	EP	2415416	A1	2/2012
EP	2090254	A1	8/2009	EP	2090253	B1	3/2012
EP	2090256	A2	8/2009	EP	2430986	A2	3/2012
EP	2095777	A2	9/2009	EP	2444008	A2	4/2012
EP	2098170	A2	9/2009	EP	1347638	B1	5/2012
EP	2110082	A1	10/2009	EP	2446834	A1	5/2012
EP	2110083	A2	10/2009	EP	2455007	A2	5/2012
EP	2110084	A2	10/2009	EP	2457519	A1	5/2012
EP	2111803	A2	10/2009	EP	2462878	A1	6/2012
EP	1813208	B1	11/2009	EP	2462880	A2	6/2012
EP	1908426	B1	11/2009	EP	1813204	B1	7/2012
EP	2116195	A1	11/2009	EP	2189121	B1	7/2012
EP	2116197	A2	11/2009	EP	2248475	B1	7/2012
EP	1607050	B1	12/2009	EP	2005895	B1	8/2012
EP	1762190	B8	12/2009	EP	2090248	B1	8/2012
EP	1815804	B1	12/2009	EP	2481359	A1	8/2012
EP	1875870	B1	12/2009	EP	2486860	A2	8/2012
EP	1878395	B1	1/2010	EP	2486862	A2	8/2012
EP	2151204	A1	2/2010	EP	1908412	B1	9/2012
EP	1813211	B1	3/2010	EP	1935351	B1	9/2012
EP	2165656	A2	3/2010	EP	2497431	A1	9/2012
EP	2165660	A2	3/2010	EP	1550412	B2	10/2012
EP	2165664	A2	3/2010	EP	1616549	B1	10/2012
EP	1566150	B1	4/2010	EP	2030579	B1	10/2012
EP	1813206	B1	4/2010	EP	2090252	B1	10/2012
EP	2184014	A2	5/2010	EP	2517637	A1	10/2012
EP	1769754	B1	6/2010	EP	2517638	A1	10/2012
EP	1854416	B1	6/2010	EP	2517642	A2	10/2012
EP	1911408	B1	6/2010	EP	2517645	A2	10/2012
EP	2198787	A1	6/2010	EP	2517649	A2	10/2012
EP	1647286	B1	9/2010	EP	2517651	A2	10/2012
EP	1825821	B1	9/2010	EP	2526877	A1	11/2012
EP	1535565	B1	10/2010	EP	2526883	A1	11/2012
				EP	2191778	B1	12/2012
				EP	1884206	B1	3/2013
				EP	2090238	B1	4/2013
				EP	1806103	B1	5/2013

(56)

References Cited

FOREIGN PATENT DOCUMENTS

EP	2586380	A1	5/2013	JP	H0731623	A	2/1995
EP	1982657	B1	7/2013	JP	H0747070	A	2/1995
EP	2614782	A2	7/2013	JP	H0751273	A	2/1995
EP	2090234	B1	9/2013	JP	H07124166	A	5/1995
EP	2633830	A1	9/2013	JP	H07163574	A	6/1995
EP	2090244	B1	10/2013	JP	H07171163	A	7/1995
EP	2644124	A1	10/2013	JP	H07255735	A	10/1995
EP	2644209	A2	10/2013	JP	H07285089	A	10/1995
EP	2649948	A1	10/2013	JP	H0833641	A	2/1996
EP	2649949	A1	10/2013	JP	H0833642	A	2/1996
EP	2700367	A1	2/2014	JP	H08164141	A	6/1996
EP	2713902	A1	4/2014	JP	H08182684	A	7/1996
EP	1772105	B1	5/2014	JP	H08507708	A	8/1996
EP	2759267	A2	7/2014	JP	H08229050	A	9/1996
EP	2777528	A2	9/2014	JP	H08336540	A	12/1996
EP	2777538	A2	9/2014	JP	H08336544	A	12/1996
EP	2446835	B1	1/2015	JP	H09501081	A	2/1997
EP	2891460	A1	7/2015	JP	H09501577	A	2/1997
EP	2923660	A2	9/2015	JP	H09164144	A	6/1997
EP	2371296	B1	8/2016	JP	H10113352	A	5/1998
EP	2116192	B1	3/2017	JP	H10118090	A	5/1998
EP	3135208	A2	3/2017	JP	H10512469	A	12/1998
EP	3005956	B1	9/2017	JP	2000014632	A	1/2000
ES	2396594	T3	2/2013	JP	2000033071	A	2/2000
FR	459743	A	11/1913	JP	2000112002	A	4/2000
FR	999646	A	2/1952	JP	2000166932	A	6/2000
FR	1112936	A	3/1956	JP	2000171730	A	6/2000
FR	2598905	A1	11/1987	JP	2000287987	A	10/2000
FR	2765794	A1	1/1999	JP	2000325303	A	11/2000
FR	2815842	A1	5/2002	JP	2001046384	A	2/2001
GB	939929	A	10/1963	JP	2001087272	A	4/2001
GB	1210522	A	10/1970	JP	2001514541	A	9/2001
GB	1217159	A	12/1970	JP	2001276091	A	10/2001
GB	1339394	A	12/1973	JP	2001286477	A	10/2001
GB	2024012	A	1/1980	JP	2001517473	A	10/2001
GB	2109241	A	6/1983	JP	2002051974	A	2/2002
GB	2272159	A	5/1994	JP	2002085415	A	3/2002
GB	2284242	A	5/1995	JP	2002143078	A	5/2002
GB	2286435	A	8/1995	JP	2002204801	A	7/2002
GB	2336214	A	10/1999	JP	2002528161	A	9/2002
GB	2425903	A	11/2006	JP	2002314298	A	10/2002
GB	2423199	B	5/2009	JP	2002369820	A	12/2002
GR	930100110	A	11/1993	JP	2003000603	A	1/2003
JP	S4711908	Y1	5/1972	JP	2003500153	A	1/2003
JP	S5033988	U	4/1975	JP	2003504104	A	2/2003
JP	S56112235	A	9/1981	JP	2003135473	A	5/2003
JP	S58500053	A	1/1983	JP	2003148903	A	5/2003
JP	S58501360	A	8/1983	JP	2003164066	A	6/2003
JP	S59174920	A	10/1984	JP	2003521301	A	7/2003
JP	S60100955	A	6/1985	JP	2003523251	A	8/2003
JP	S60212152	A	10/1985	JP	2003523254	A	8/2003
JP	S6198249	A	5/1986	JP	2003300416	A	10/2003
JP	S61502036	A	9/1986	JP	2004147701	A	5/2004
JP	S62170011	U	10/1987	JP	2004162035	A	6/2004
JP	S6359764	A	3/1988	JP	2004229976	A	8/2004
JP	S63147449	A	6/1988	JP	2004524076	A	8/2004
JP	S63203149	A	8/1988	JP	2004531280	A	10/2004
JP	H02279149	A	11/1990	JP	2004532084	A	10/2004
JP	H0312126	A	1/1991	JP	2004532676	A	10/2004
JP	H04215747	A	8/1992	JP	2004329624	A	11/2004
JP	H04131860	U	12/1992	JP	2004337617	A	12/2004
JP	H0584252	A	4/1993	JP	2004344662	A	12/2004
JP	H05123325	A	5/1993	JP	2004344663	A	12/2004
JP	H05212039	A	8/1993	JP	2005013573	A	1/2005
JP	H067357	A	1/1994	JP	2005028147	A	2/2005
JP	H0630945	A	2/1994	JP	2005028148	A	2/2005
JP	H0654857	A	3/1994	JP	2005028149	A	2/2005
JP	H0663054	A	3/1994	JP	2005505309	A	2/2005
JP	H0626812	U	4/1994	JP	2005505322	A	2/2005
JP	H06121798	A	5/1994	JP	2005505334	A	2/2005
JP	H06125913	A	5/1994	JP	2005080702	A	3/2005
JP	H06197901	A	7/1994	JP	2005103280	A	4/2005
JP	H06237937	A	8/1994	JP	2005103281	A	4/2005
JP	H06327684	A	11/1994	JP	2005103293	A	4/2005
JP	H079622	U	2/1995	JP	2005511131	A	4/2005
				JP	2005511137	A	4/2005
				JP	2005131163	A	5/2005
				JP	2005131164	A	5/2005
				JP	2005131173	A	5/2005

(56)

References Cited

FOREIGN PATENT DOCUMENTS

JP	2005131211	A	5/2005	JP	2009539420	A	11/2009
JP	2005131212	A	5/2005	JP	2009291604	A	12/2009
JP	2005137423	A	6/2005	JP	2010504808	A	2/2010
JP	2005137919	A	6/2005	JP	2010504809	A	2/2010
JP	2005144183	A	6/2005	JP	2010504846	A	2/2010
JP	2005152416	A	6/2005	JP	2010505524	A	2/2010
JP	2005516714	A	6/2005	JP	2010069310	A	4/2010
JP	2005521109	A	7/2005	JP	2010075695	A	4/2010
JP	2005523105	A	8/2005	JP	2010088876	A	4/2010
JP	2005524474	A	8/2005	JP	2010098844	A	4/2010
JP	2005296412	A	10/2005	JP	4461008	B2	5/2010
JP	2005328882	A	12/2005	JP	4549018	B2	9/2010
JP	2005335432	A	12/2005	JP	2010214166	A	9/2010
JP	2005342267	A	12/2005	JP	2010540192	A	12/2010
JP	2006034975	A	2/2006	JP	4783373	B2	9/2011
JP	2006034977	A	2/2006	JP	2011524199	A	9/2011
JP	2006034978	A	2/2006	JP	5140421	B2	2/2013
JP	2006034980	A	2/2006	JP	5162595	B2	3/2013
JP	2006506106	A	2/2006	JP	2013128791	A	7/2013
JP	2006510879	A	3/2006	JP	5333899	B2	11/2013
JP	2006187649	A	7/2006	KR	20110003229	A	1/2011
JP	2006218297	A	8/2006	RU	2008830	C1	3/1994
JP	2006223872	A	8/2006	RU	2052979	C1	1/1996
JP	2006281405	A	10/2006	RU	2098025	C1	12/1997
JP	2006289064	A	10/2006	RU	2141279	C1	11/1999
JP	2006334412	A	12/2006	RU	2144791	C1	1/2000
JP	2006334417	A	12/2006	RU	2181566	C2	4/2002
JP	2006346445	A	12/2006	RU	2187249	C2	8/2002
JP	2007000634	A	1/2007	RU	2189091	C2	9/2002
JP	2007050253	A	3/2007	RU	32984	U1	10/2003
JP	2007061628	A	3/2007	RU	2225170	C2	3/2004
JP	3906843	B2	4/2007	RU	42750	U1	12/2004
JP	2007083051	A	4/2007	RU	61114	U1	2/2007
JP	2007098130	A	4/2007	SU	189517	A	1/1967
JP	2007105481	A	4/2007	SU	328636	A	9/1972
JP	2007117725	A	5/2007	SU	674747	A1	7/1979
JP	2007130471	A	5/2007	SU	886900	A1	12/1981
JP	2007130479	A	5/2007	SU	1009439	A	4/1983
JP	3934161	B2	6/2007	SU	1022703	A1	6/1983
JP	2007203049	A	8/2007	SU	1333319	A2	8/1987
JP	2007203051	A	8/2007	SU	1377053	A1	2/1988
JP	2007203055	A	8/2007	SU	1509051	A1	9/1989
JP	2007203057	A	8/2007	SU	1561964	A1	5/1990
JP	2007524435	A	8/2007	SU	1708312	A1	1/1992
JP	2007222615	A	9/2007	SU	1722476	A1	3/1992
JP	2007229448	A	9/2007	SU	1752361	A1	8/1992
JP	4001860	B2	10/2007	SU	1814161	A1	5/1993
JP	2007252916	A	10/2007	WO	WO-8202824	A1	9/1982
JP	2007307373	A	11/2007	WO	WO-8602254	A1	4/1986
JP	2007325922	A	12/2007	WO	WO-9115157	A1	10/1991
JP	2008068073	A	3/2008	WO	WO-9220295	A1	11/1992
JP	2008206967	A	9/2008	WO	WO-9221300	A1	12/1992
JP	2008212637	A	9/2008	WO	WO-9308755	A1	5/1993
JP	2008212638	A	9/2008	WO	WO-9313718	A1	7/1993
JP	2008220956	A	9/2008	WO	WO-9314690	A1	8/1993
JP	2008237881	A	10/2008	WO	WO-9315648	A1	8/1993
JP	2008259860	A	10/2008	WO	WO-9315850	A1	8/1993
JP	2008264535	A	11/2008	WO	WO-9319681	A1	10/1993
JP	2008283459	A	11/2008	WO	WO-9400060	A1	1/1994
JP	2009006137	A	1/2009	WO	WO-9411057	A1	5/1994
JP	2009502351	A	1/2009	WO	WO-9412108	A1	6/1994
JP	2009502352	A	1/2009	WO	WO-9417737	A1	8/1994
JP	2009022742	A	2/2009	WO	WO-9418893	A1	9/1994
JP	2009506799	A	2/2009	WO	WO-9420030	A1	9/1994
JP	2009507526	A	2/2009	WO	WO-9422378	A1	10/1994
JP	2009072599	A	4/2009	WO	WO-9423659	A1	10/1994
JP	2009090113	A	4/2009	WO	WO-9424943	A1	11/1994
JP	2009106752	A	5/2009	WO	WO-9424947	A1	11/1994
JP	2009189836	A	8/2009	WO	WO-9502369	A1	1/1995
JP	2009189837	A	8/2009	WO	WO-9503743	A1	2/1995
JP	2009189838	A	8/2009	WO	WO-9506817	A1	3/1995
JP	2009201998	A	9/2009	WO	WO-9509576	A1	4/1995
JP	2009536082	A	10/2009	WO	WO-9509577	A1	4/1995
JP	2009261944	A	11/2009	WO	WO-9514436	A1	6/1995
JP	2009268908	A	11/2009	WO	WO-9517855	A1	7/1995
				WO	WO-9518383	A1	7/1995
				WO	WO-9518572	A1	7/1995
				WO	WO-9519739	A1	7/1995
				WO	WO-9520360	A1	8/1995

(56)

References Cited

FOREIGN PATENT DOCUMENTS

WO	WO-9523557	A1	9/1995	WO	WO-0135845	A1	5/2001
WO	WO-9524865	A1	9/1995	WO	WO-0154594	A1	8/2001
WO	WO-9525471	A3	9/1995	WO	WO-0158371	A1	8/2001
WO	WO-9526562	A1	10/1995	WO	WO-0162158	A2	8/2001
WO	WO-9529639	A1	11/1995	WO	WO-0162161	A1	8/2001
WO	WO-9604858	A1	2/1996	WO	WO-0162162	A1	8/2001
WO	WO-9618344	A2	6/1996	WO	WO-0162163	A1	8/2001
WO	WO-9619151	A1	6/1996	WO	WO-0162164	A2	8/2001
WO	WO-9619152	A1	6/1996	WO	WO-0162169	A2	8/2001
WO	WO-9620652	A1	7/1996	WO	WO-0178605	A2	10/2001
WO	WO-9621119	A1	7/1996	WO	WO-0180757	A2	11/2001
WO	WO-9622055	A1	7/1996	WO	WO-0191646	A1	12/2001
WO	WO-9623448	A1	8/1996	WO	WO-0200121	A1	1/2002
WO	WO-9624301	A1	8/1996	WO	WO-0207608	A2	1/2002
WO	WO-9627337	A1	9/1996	WO	WO-0207618	A1	1/2002
WO	WO-9631155	A1	10/1996	WO	WO-0217799	A1	3/2002
WO	WO-9635464	A1	11/1996	WO	WO-0219920	A1	3/2002
WO	WO-9639085	A1	12/1996	WO	WO-0219932	A1	3/2002
WO	WO-9639086	A1	12/1996	WO	WO-0226143	A1	4/2002
WO	WO-9639087	A1	12/1996	WO	WO-0230297	A2	4/2002
WO	WO-9639088	A1	12/1996	WO	WO-0232322	A2	4/2002
WO	WO-9639089	A1	12/1996	WO	WO-0236028	A1	5/2002
WO	WO-9700646	A1	1/1997	WO	WO-0243571	A2	6/2002
WO	WO-9700647	A1	1/1997	WO	WO-02058568	A1	8/2002
WO	WO-9701989	A1	1/1997	WO	WO-02060328	A1	8/2002
WO	WO-9706582	A1	2/1997	WO	WO-02065933	A2	8/2002
WO	WO-9710763	A1	3/1997	WO	WO-02067785	A2	9/2002
WO	WO-9710764	A1	3/1997	WO	WO-02080781	A2	10/2002
WO	WO-9711648	A2	4/1997	WO	WO-02085218	A2	10/2002
WO	WO-9711649	A1	4/1997	WO	WO-02087586	A1	11/2002
WO	WO-9715237	A1	5/1997	WO	WO-02098302	A1	12/2002
WO	WO-9724073	A1	7/1997	WO	WO-03000138	A2	1/2003
WO	WO-9724993	A1	7/1997	WO	WO-03001329	A2	1/2003
WO	WO-9730644	A1	8/1997	WO	WO-03001986	A2	1/2003
WO	WO-9734533	A1	9/1997	WO	WO-03013363	A1	2/2003
WO	WO-9737598	A1	10/1997	WO	WO-03013372	A2	2/2003
WO	WO-9739688	A2	10/1997	WO	WO-03015604	A2	2/2003
WO	WO-9801080	A1	1/1998	WO	WO-03020106	A2	3/2003
WO	WO-9817180	A1	4/1998	WO	WO-03020139	A2	3/2003
WO	WO-9822154	A2	5/1998	WO	WO-03024339	A1	3/2003
WO	WO-9827880	A1	7/1998	WO	WO-03030743	A2	4/2003
WO	WO-9830153	A1	7/1998	WO	WO-03037193	A1	5/2003
WO	WO-9847436	A1	10/1998	WO	WO-03055402	A1	7/2003
WO	WO-9858589	A1	12/1998	WO	WO-03057048	A1	7/2003
WO	WO-9902090	A1	1/1999	WO	WO-03057058	A1	7/2003
WO	WO-9903407	A1	1/1999	WO	WO-03063694	A1	8/2003
WO	WO-9903408	A1	1/1999	WO	WO-03077769	A1	9/2003
WO	WO-9903409	A1	1/1999	WO	WO-03079911	A1	10/2003
WO	WO-9912483	A1	3/1999	WO	WO-03082126	A1	10/2003
WO	WO-9912487	A1	3/1999	WO	WO-03086206	A1	10/2003
WO	WO-9912488	A1	3/1999	WO	WO-03088845	A2	10/2003
WO	WO-9915086	A1	4/1999	WO	WO-03047436	A3	11/2003
WO	WO-9915091	A1	4/1999	WO	WO-03090630	A2	11/2003
WO	WO-9923933	A2	5/1999	WO	WO-03094743	A1	11/2003
WO	WO-9923959	A1	5/1999	WO	WO-03094745	A1	11/2003
WO	WO-9925261	A1	5/1999	WO	WO-03094746	A1	11/2003
WO	WO-9929244	A1	6/1999	WO	WO-03094747	A1	11/2003
WO	WO-9934744	A1	7/1999	WO	WO-03101313	A1	12/2003
WO	WO-9945849	A1	9/1999	WO	WO-03105698	A2	12/2003
WO	WO-9948430	A1	9/1999	WO	WO-03105702	A2	12/2003
WO	WO-9951158	A1	10/1999	WO	WO-2004004578	A1	1/2004
WO	WO-0024322	A1	5/2000	WO	WO-2004006980	A2	1/2004
WO	WO-0024330	A1	5/2000	WO	WO-2004011037	A2	2/2004
WO	WO-0041638	A1	7/2000	WO	WO-2004014238	A2	2/2004
WO	WO-0048506	A1	8/2000	WO	WO-03079909	A3	3/2004
WO	WO-0053112	A2	9/2000	WO	WO-2004019769	A1	3/2004
WO	WO-0054653	A1	9/2000	WO	WO-2004019803	A1	3/2004
WO	WO-0057796	A1	10/2000	WO	WO-2004021868	A2	3/2004
WO	WO-0064365	A1	11/2000	WO	WO-2004028585	A2	4/2004
WO	WO-0072762	A1	12/2000	WO	WO-2004030554	A1	4/2004
WO	WO-0072765	A1	12/2000	WO	WO-2004032754	A2	4/2004
WO	WO-0078222	A1	12/2000	WO	WO-2004032760	A2	4/2004
WO	WO-0103587	A1	1/2001	WO	WO-2004032762	A1	4/2004
WO	WO-0105702	A1	1/2001	WO	WO-2004032763	A2	4/2004
WO	WO-0110482	A1	2/2001	WO	WO-2004032783	A1	4/2004
				WO	WO-2004034875	A2	4/2004
				WO	WO-2004047626	A1	6/2004
				WO	WO-2004047653	A2	6/2004
				WO	WO-2004049956	A2	6/2004

(56)

References Cited

FOREIGN PATENT DOCUMENTS

WO WO-2004050971 A2 6/2004
 WO WO-2004052426 A2 6/2004
 WO WO-2004056276 A1 7/2004
 WO WO-2004056277 A1 7/2004
 WO WO-2004058079 A2 7/2004
 WO WO-2004062516 A1 7/2004
 WO WO-2004064600 A2 8/2004
 WO WO-2004078050 A2 9/2004
 WO WO-2004078051 A2 9/2004
 WO WO-2004078236 A2 9/2004
 WO WO-2004086987 A1 10/2004
 WO WO-2004096015 A2 11/2004
 WO WO-2004096057 A2 11/2004
 WO WO-2004103157 A2 12/2004
 WO WO-2004105593 A1 12/2004
 WO WO-2004105621 A1 12/2004
 WO WO-2004112618 A2 12/2004
 WO WO-2004112652 A2 12/2004
 WO WO-2005027983 A2 3/2005
 WO WO-2005037329 A2 4/2005
 WO WO-2005042041 A1 5/2005
 WO WO-2005044078 A2 5/2005
 WO WO-2005055846 A1 6/2005
 WO WO-2005072634 A2 8/2005
 WO WO-2005078892 A1 8/2005
 WO WO-2005079675 A2 9/2005
 WO WO-2005087128 A1 9/2005
 WO WO-2005096954 A2 10/2005
 WO WO-2005112806 A2 12/2005
 WO WO-2005112808 A1 12/2005
 WO WO-2005115251 A1 12/2005
 WO WO-2005115253 A2 12/2005
 WO WO-2005117735 A1 12/2005
 WO WO-2005122936 A1 12/2005
 WO WO-2006023486 A1 3/2006
 WO WO-2006023578 A2 3/2006
 WO WO-2006027014 A1 3/2006
 WO WO-2006028314 A1 3/2006
 WO WO-2006044490 A2 4/2006
 WO WO-2006044581 A2 4/2006
 WO WO-2006044810 A2 4/2006
 WO WO-2006049852 A2 5/2006
 WO WO-2006051252 A1 5/2006
 WO WO-2006059067 A1 6/2006
 WO WO-2006083748 A1 8/2006
 WO WO-2006085389 A1 8/2006
 WO WO-2006092563 A1 9/2006
 WO WO-2006092565 A1 9/2006
 WO WO-2006115958 A1 11/2006
 WO WO-2006125940 A1 11/2006
 WO WO-2006132992 A2 12/2006
 WO WO-2007002180 A2 1/2007
 WO WO-2007016290 A2 2/2007
 WO WO-2007018898 A2 2/2007
 WO WO-2007059233 A2 5/2007
 WO WO-2007074430 A1 7/2007
 WO WO-2007089603 A2 8/2007
 WO WO-2007098220 A2 8/2007
 WO WO-2007121579 A1 11/2007
 WO WO-2007129121 A1 11/2007
 WO WO-2007131110 A2 11/2007
 WO WO-2007137304 A2 11/2007
 WO WO-2007139734 A2 12/2007
 WO WO-2007142625 A2 12/2007
 WO WO-2007145825 A2 12/2007
 WO WO-2007146987 A2 12/2007
 WO WO-2007147439 A1 12/2007
 WO WO-2008020964 A2 2/2008
 WO WO-2008021969 A2 2/2008
 WO WO-2008039237 A1 4/2008
 WO WO-2008039249 A1 4/2008
 WO WO-2008039270 A1 4/2008
 WO WO-2008045383 A2 4/2008
 WO WO-2008057281 A2 5/2008
 WO WO-2008070763 A1 6/2008

WO WO-2008089404 A2 7/2008
 WO WO-2008101080 A1 8/2008
 WO WO-2008101228 A2 8/2008
 WO WO-2008103797 A2 8/2008
 WO WO-2008109125 A1 9/2008
 WO WO-2008112912 A2 9/2008
 WO WO-2008118728 A1 10/2008
 WO WO-2008124748 A1 10/2008
 WO WO-2009005969 A2 1/2009
 WO WO-2009022614 A1 2/2009
 WO WO-2009023851 A1 2/2009
 WO WO-2009033057 A2 3/2009
 WO WO-2009039506 A1 3/2009
 WO WO-2009046394 A1 4/2009
 WO WO-2009067649 A2 5/2009
 WO WO-2009091497 A2 7/2009
 WO WO-2009120944 A2 10/2009
 WO WO-2009137761 A2 11/2009
 WO WO-2009143092 A1 11/2009
 WO WO-2009143331 A1 11/2009
 WO WO-2009150650 A2 12/2009
 WO WO-2009152307 A1 12/2009
 WO WO-2010028332 A2 3/2010
 WO WO-2010030434 A1 3/2010
 WO WO-2010045425 A1 4/2010
 WO WO-2010050771 A2 5/2010
 WO WO-2010054404 A1 5/2010
 WO WO-2010056714 A1 5/2010
 WO WO-2010063795 A1 6/2010
 WO WO-2010090940 A1 8/2010
 WO WO-2010093333 A1 8/2010
 WO WO-2010098871 A2 9/2010
 WO WO-2011008672 A2 1/2011
 WO WO-2011013103 A1 2/2011
 WO WO-2011044343 A2 4/2011
 WO WO-2011060311 A2 5/2011
 WO WO-2012006306 A2 1/2012
 WO WO-2012/013577 A1 2/2012
 WO WO-2012021671 A1 2/2012
 WO WO-2012040438 A1 3/2012
 WO WO-2012044551 A1 4/2012
 WO WO-2012044554 A1 4/2012
 WO WO-2012044597 A1 4/2012
 WO WO-2012044606 A2 4/2012
 WO WO-2012044820 A1 4/2012
 WO WO-2012044844 A2 4/2012
 WO WO-2012044853 A1 4/2012
 WO WO-2012058213 A2 5/2012
 WO WO-2012068156 A2 5/2012
 WO WO-2012127462 A1 9/2012
 WO WO-2012135705 A1 10/2012
 WO WO-2012143913 A2 10/2012
 WO WO-2012148667 A2 11/2012
 WO WO-2012148703 A2 11/2012
 WO WO-2012160163 A1 11/2012
 WO WO-2012166503 A1 12/2012
 WO WO-2013009699 A2 1/2013
 WO WO-2013016633 A1 1/2013
 WO WO-2013036409 A1 3/2013
 WO WO-2013043707 A2 3/2013
 WO WO-2013043717 A1 3/2013
 WO WO-2013043721 A2 3/2013
 WO WO-2013062978 A2 5/2013
 WO WO-2013148762 A2 10/2013
 WO WO-2013167427 A1 11/2013
 WO WO-2014004199 A1 1/2014
 WO WO-2014004294 A2 1/2014
 WO WO-2016/057225 A1 4/2016

OTHER PUBLICATIONS

“Indian Standard: Automotive Vehicles—Brakes and Braking Systems (IS 11852-1:2001)”, Mar. 1, 2001.
 Anonymous: “Stamping (metalworking)—Wikipedia,” Jun. 6, 2016, Retrieved from the Internet: URL: [https://en.wikipedia.org/w/index.php?title=Stamping_\(metalworking\)&oldid=723906245](https://en.wikipedia.org/w/index.php?title=Stamping_(metalworking)&oldid=723906245) [retrieved on May 15, 2018].
 ASTM procedure D2240-00, “Standard Test Method for Rubber Property-Durometer Hardness,” (Published Aug. 2000).

(56)

References Cited

OTHER PUBLICATIONS

ASTM procedure D2240-05, "Standard Test Method for Rubber Property-Durometer Hardness," (Published Apr. 2010).

B.R. Coolman, DVM, MS et al., "Comparison of Skin Staples With Sutures for Anastomosis of the Small Intestine in Dogs," Abstract; <http://www.blackwell-synergy.com/doi/abs/10.1053/jvet.2000.7539?cookieSet=1&journalCode=vsu> which redirects to <http://www3.interscience.wiley.com/journal/119040681/abstract?CRETRY=1&SRETRY=0>; [online] accessed: Sep. 22, 2008 (2 pages).

Brar et al., "Investigation of the mechanical and degradation properties of Mg-Sr and Mg-Zn-Sr alloys for use as potential biodegradable implant materials," *J. Mech. Behavior of Biomed. Mater.* 7 (2012) pp. 87-95.

Breedveld et al., "A New, Easily Miniaturized Sterrable Endoscope," *IEEE Engineering in Medicine and Biology Magazine* (Nov./Dec. 2005).

Byrne et al., "Molecular Imprinting Within Hydrogels," *Advanced Drug Delivery Reviews*, 54 (2002) pp. 149-161.

C.C. Thompson et al., "Peroral Endoscopic Reduction of Dilated Gastrojejunal Anastomosis After Roux-en-Y Gastric Bypass: A Possible New Option for Patients with Weight Regain," *Surg Endosc* (2006) vol. 20., pp. 1744-1748.

Chen et al., "Elastomeric Biomaterials for Tissue Engineering," *Progress in Polymer Science* 38 (2013), pp. 584-671.

Covidien Brochure, "Endo GIA™ Curved Tip Reload with Tri-Staple™ Technology," (2012), 2 pages.

Covidien Brochure, "Endo GIA™ Reloads with Tri-Staple™ Technology and Endo GIA™ Ultra Universal Staplers," (2010), 2 pages.

Covidien Brochure, "Endo GIA™ Reloads with Tri-Staple™ Technology," (2010), 1 page.

Covidien Brochure, "Endo GIA™ Reloads with Tri-Staple™ Technology," (2010), 2 pages.

Covidien Brochure, "Endo GIA™ Black Reload with Tri-Staple™ Technology," (2012), 2 pages.

Covidien Brochure, "Endo GIA™ Ultra Universal Stapler," (2010), 2 pages.

D. Tuite, Ed., "Get the Lowdown On Ultracapacitors," Nov. 15, 2007; [online] URL: <http://electronicdesign.com/Articles/Print.cfm?ArticleID=17465>, accessed Jan. 15, 2008 (5 pages).

Datasheet for Panasonic TK Relays Ultra Low Profile 2 A Polarized Relay, Copyright Matsushita Electric Works, Ltd. (Known of at least as early as Aug. 17, 2010), 5 pages.

Disclosed Anonymously, "Motor-Driven Surgical Stapler Improvements," Research Disclosure Database No. 526041, Published: Feb. 2008.

Ebara, "Carbohydrate-Derived Hydrogels and Microgels," *Engineered Carbohydrate-Based Materials for Biomedical Applications: Polymers, Surfaces, Dendrimers, Nanoparticles, and Hydrogels*, Edited by Ravin Narain, 2011, pp. 337-345.

Erdmann et al., "Evaluation of the Soft Tissue Biocompatibility of MgCa0.8 and Surgical Steel 316L in vivo: A Comparative Study in Rabbits," *Biomed. Eng. OnLine* 2010 9:63 (17 pages).

Fast, Versatile Blackfin Processors Handle Advanced RFID Reader Applications; *Analog Dialogue*: vol. 40—Sep. 2006; <http://www.analog.com/library/analogDialogue/archives/40-09/rfid.pdf>; Wayback Machine to Feb. 15, 2012.

Hoffman, "Hydrogels for Biomedical Applications," *Advanced Drug Delivery Reviews*, 43 (2002) pp. 3-12.

Hoffman, "Hydrogels for Biomedical Applications," *Advanced Drug Delivery Reviews*, 54 (2002) pp. 3-12.

<http://ninpgan.net/publications/51-100/89.pdf>; 2004, Ning Pan, On Uniqueness of Fibrous Materials, *Design & Nature II*. Eds: Colins, M. and Brebbia, C. WIT Press, Boston, 493-504.

Jeong et al., "Thermosensitive Sol-Gel Reversible Hydrogels," *Advanced Drug Delivery Reviews*, 54 (2002) pp. 37-51.

Matsuda, "Thermodynamics of Formation of Porous Polymeric Membrane from Solutions," *Polymer Journal*, vol. 23, No. 5, pp. 435-444 (1991).

Miyata et al., "Biomolecule-Sensitive Hydrogels," *Advanced Drug Delivery Reviews*, 54 (2002) pp. 79-98.

Peppas, "Physiologically Responsive Hydrogels," *Journal of Bioactive and Compatible Polymers*, vol. 6 (Jul. 1991) pp. 241-246.

Peppas, Editor "Hydrogels in Medicine and Pharmacy," vol. I, *Fundamentals*, CRC Press, 1986.

Pitt et al., "Attachment of Hyaluronan to Metallic Surfaces," *J. Biomed. Mater. Res.* 68A: pp. 95-106, 2004.

Qiu et al., "Environment-Sensitive Hydrogels for Drug Delivery," *Advanced Drug Delivery Reviews*, 53 (2001) pp. 321-339.

Schellhammer et al., "Poly-Lactic-Acid for Coating of Endovascular Stents: Preliminary Results in Canine Experimental Av-Fistulae," *Mat.-wiss. u. Werkstofftech.*, 32, pp. 193-199 (2001).

Serial Communication Protocol; Michael Lemmon Feb. 1, 2009; <http://www3.nd.edu/~lemmon/courses/ee224/web-manual/web-manual/lab12/node2.html>; Wayback Machine to Apr. 29, 2012.

Solorio et al., "Gelatin Microspheres Crosslinked with Genipin for Local Delivery of Growth Factors," *J. Tissue Eng. Regen. Med.* (2010), 4(7): pp. 514-523.

The Sodem Aseptic Battery Transfer Kit, Sodem Systems, 2000, 3 pages.

Van Meer et al., "A Disposable Plastic Compact Wrist for Smart Minimally Invasive Surgical Tools," *LAAS/CNRS* (Aug. 2005).

Yan et al, Comparison of the effects of Mg-6Zn and Ti-3Al-2.5V alloys on TGF-β8/TNF-α/VEGF/b-FGF in the healing of the intestinal track in vivo, *Biomed. Mater.* 9 (2014), 11 pages.

Yan et al., "Comparison of the effects of Mg-6Zn and titanium on intestinal tract in vivo," *J Mater Sci: Mater Med* (2013), 11 pages.

Young, "Microcellular foams via phase separation," *Journal of Vacuum Science & Technology A* 4(3), (May/Jun. 1986).

* cited by examiner

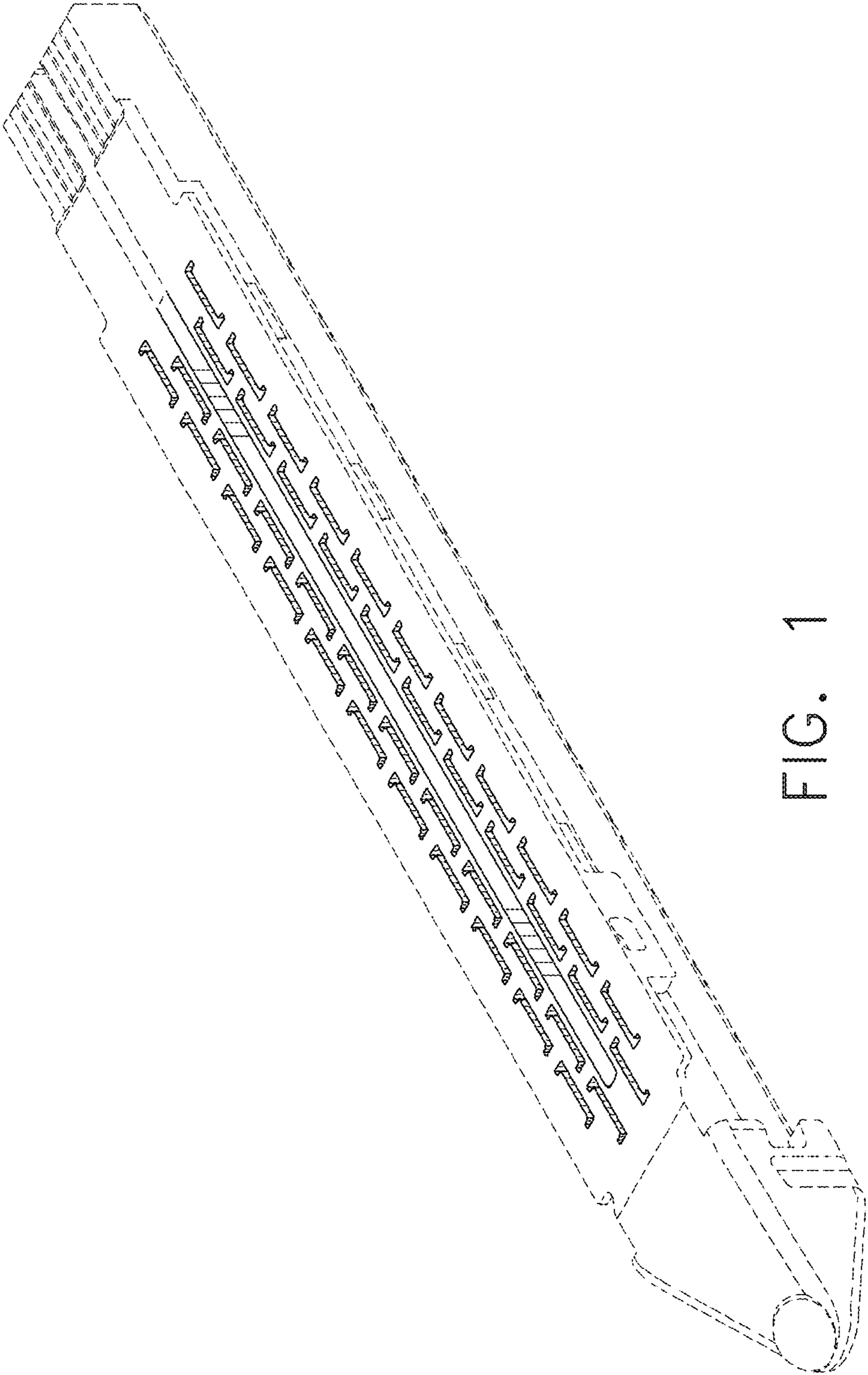

FIG. 1

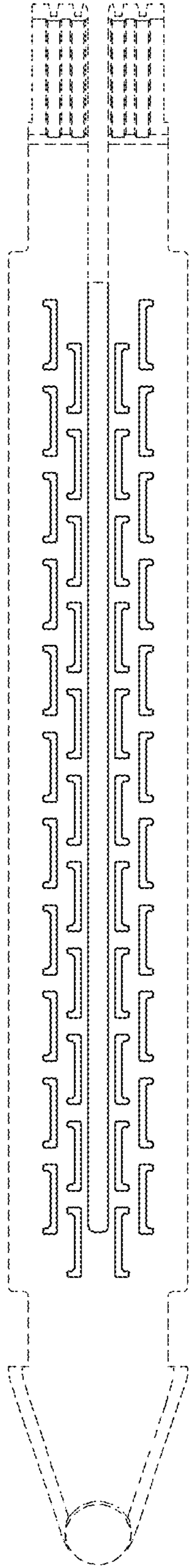

FIG. 2

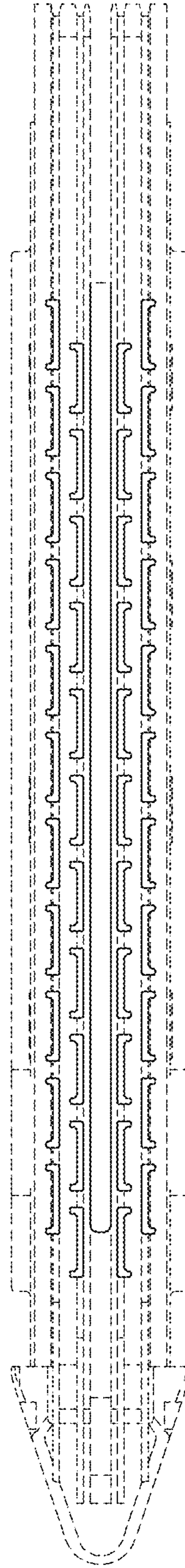

FIG. 3

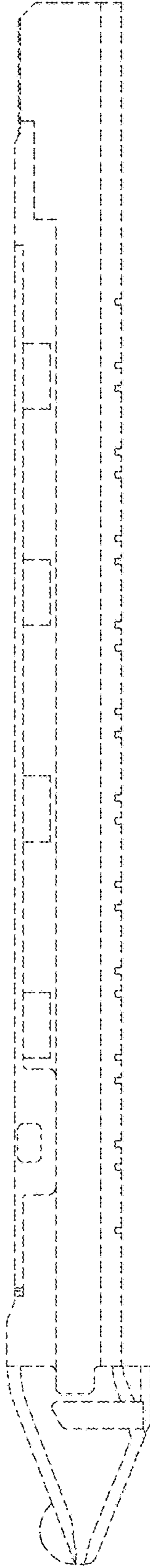

FIG. 4

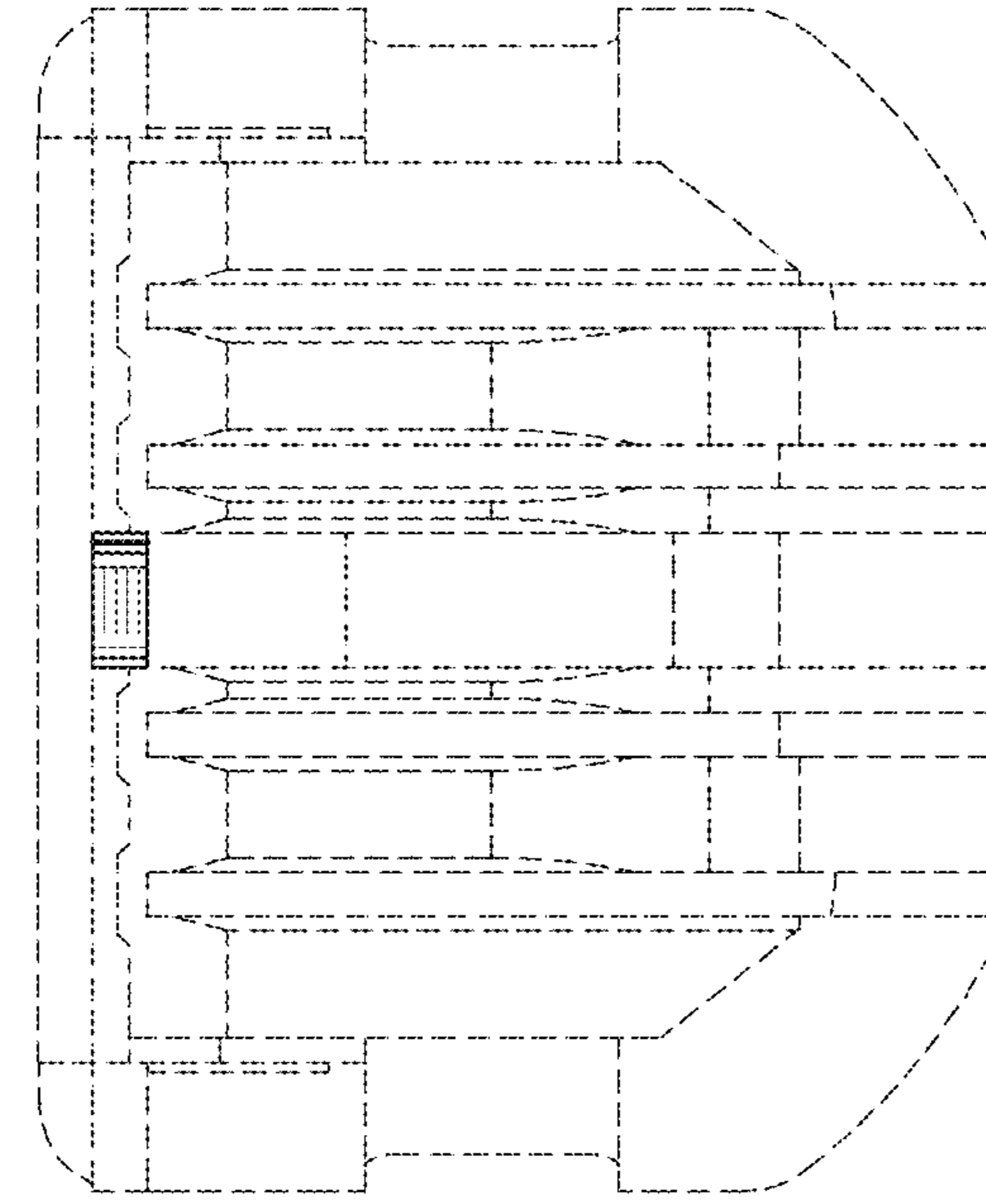

FIG. 5

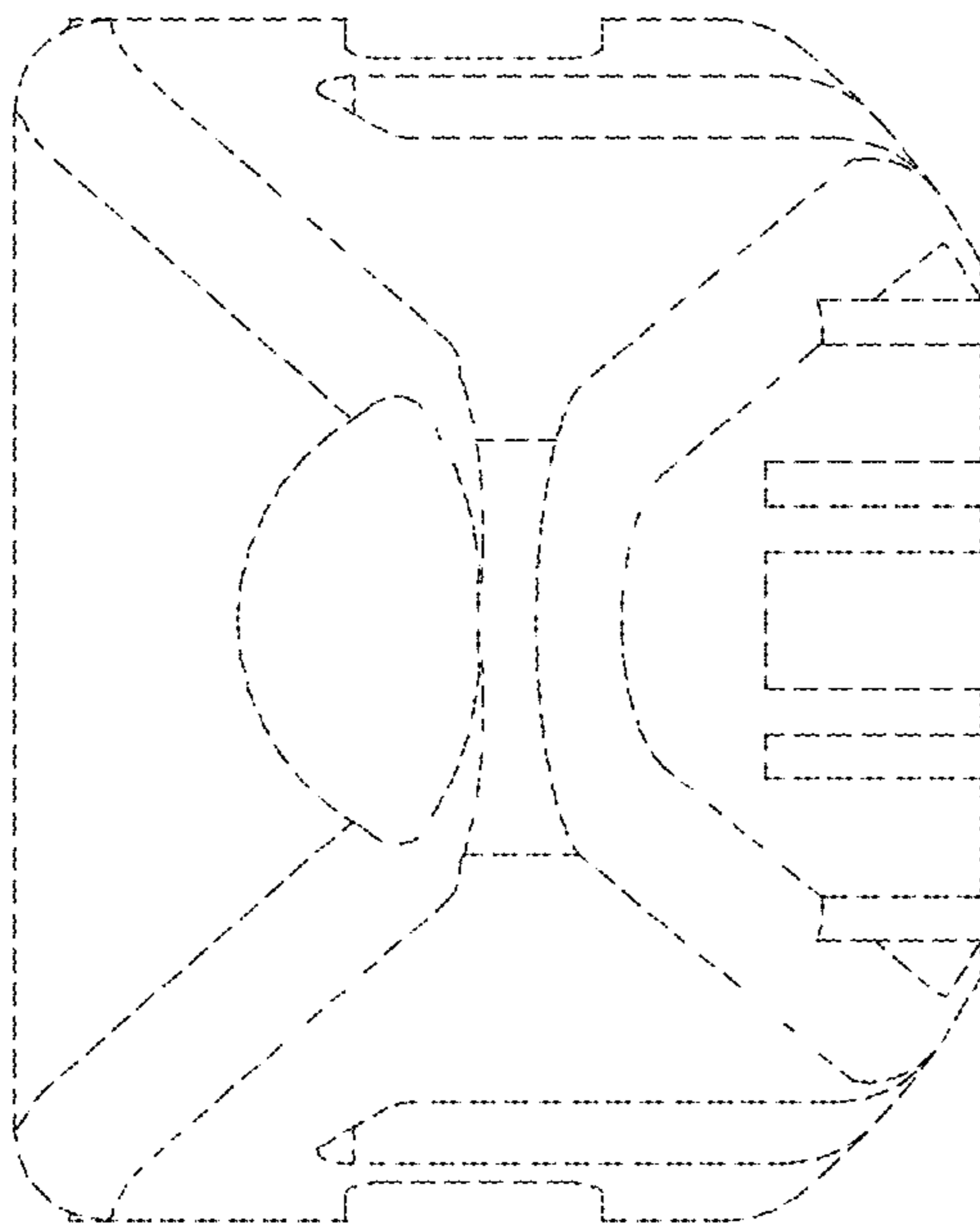

FIG. 6