



US00D850374S

(12) **United States Design Patent** (10) **Patent No.:** **US D850,374 S**
Schmitt et al. (45) **Date of Patent:** **** Jun. 4, 2019**

(54) **THERMODYNAMIC CONVERTER**

(71) Applicant: **ORCAN ENERGY AG**, München (DE)

(72) Inventors: **Max Schmitt**, Korschbroich (DE); **Stefan Reichl**, München (DE)

(73) Assignee: **ORCAN ENERGY AG**, München (DE)

(**) Term: **15 Years**

(21) Appl. No.: **29/569,197**

(22) Filed: **Jun. 24, 2016**

(30) **Foreign Application Priority Data**

Dec. 24, 2015 (EM) 002922898-0001
Dec. 24, 2015 (EM) 002922898-0002
Dec. 24, 2015 (EM) 002922898-0003
Dec. 24, 2015 (EM) 002922898-0004

(51) **LOC (11) Cl.** **13-02**

(52) **U.S. Cl.**
USPC **D13/110**

(58) **Field of Classification Search**

USPC D13/101, 102, 107, 108, 110, 112, 118,
D13/119, 123, 133, 138.1, 162, 184, 199;
D9/414
CPC H02P 27/04; H02P 27/06; H02P 27/047;
H02P 2201/09; H02P 2201/11; H02M
2001/0067; H02M 2001/007; H02M
2001/0045; H02M 2001/0083; H02M
2001/009; H02M 7/003; H02M 7/06;
H02M 7/00; G06F 1/00; G06F 1/188;
G06F 1/189; G06F 1/26; G06F 11/2015;
H01R 13/66; H01R 13/60; H01R 13/72;
H01R 13/6675; H01R 31/065; H05K
5/0021; H05K 5/0208; H05K 5/0247;
H05K 5/00

See application file for complete search history.

(56) **References Cited**

U.S. PATENT DOCUMENTS

D453,139 S * 1/2002 Yang D13/110
D605,589 S * 12/2009 Zeng D13/110
7,815,869 B2 * 10/2010 Wang B01J 35/0006
29/890

(Continued)

OTHER PUBLICATIONS

CircuitsToday.com: Convert Unwanted Exhaust Heat into Useful Energy. Published Jun. 13, 2011. Retrieved from the internet at <http://www.circuitstoday.com/convert-unwanted-exhaust-heat-into-useful-energy>, Mar. 31, 2017. 1 page.*

(Continued)

Primary Examiner — Rosemary K Tarcza

Assistant Examiner — Christy M Nemeth

(74) *Attorney, Agent, or Firm* — Moore & Van Allen PLLC; Henry B. Ward, III

(57) **CLAIM**

The ornamental design for a thermodynamic converter, as shown and described.

DESCRIPTION

FIG. 1 is a front, top, and left-side perspective view of a thermodynamic converter;
FIG. 2 is a front-elevation view thereof;
FIG. 3 is a rear-elevation view thereof;
FIG. 4 is a left-elevation view thereof;
FIG. 5 is a right-elevation view thereof;
FIG. 6 is a top-plan view thereof; and,
FIG. 7 is a bottom-plan view thereof.

The broken lines in the drawings are for the purpose of illustrating portions of the thermodynamic converter that form no part of the claimed design.

The solid stripe in the drawings is for the purpose of illustrating color contrast between the stripe and the adjacent surfaces.

1 Claim, 7 Drawing Sheets

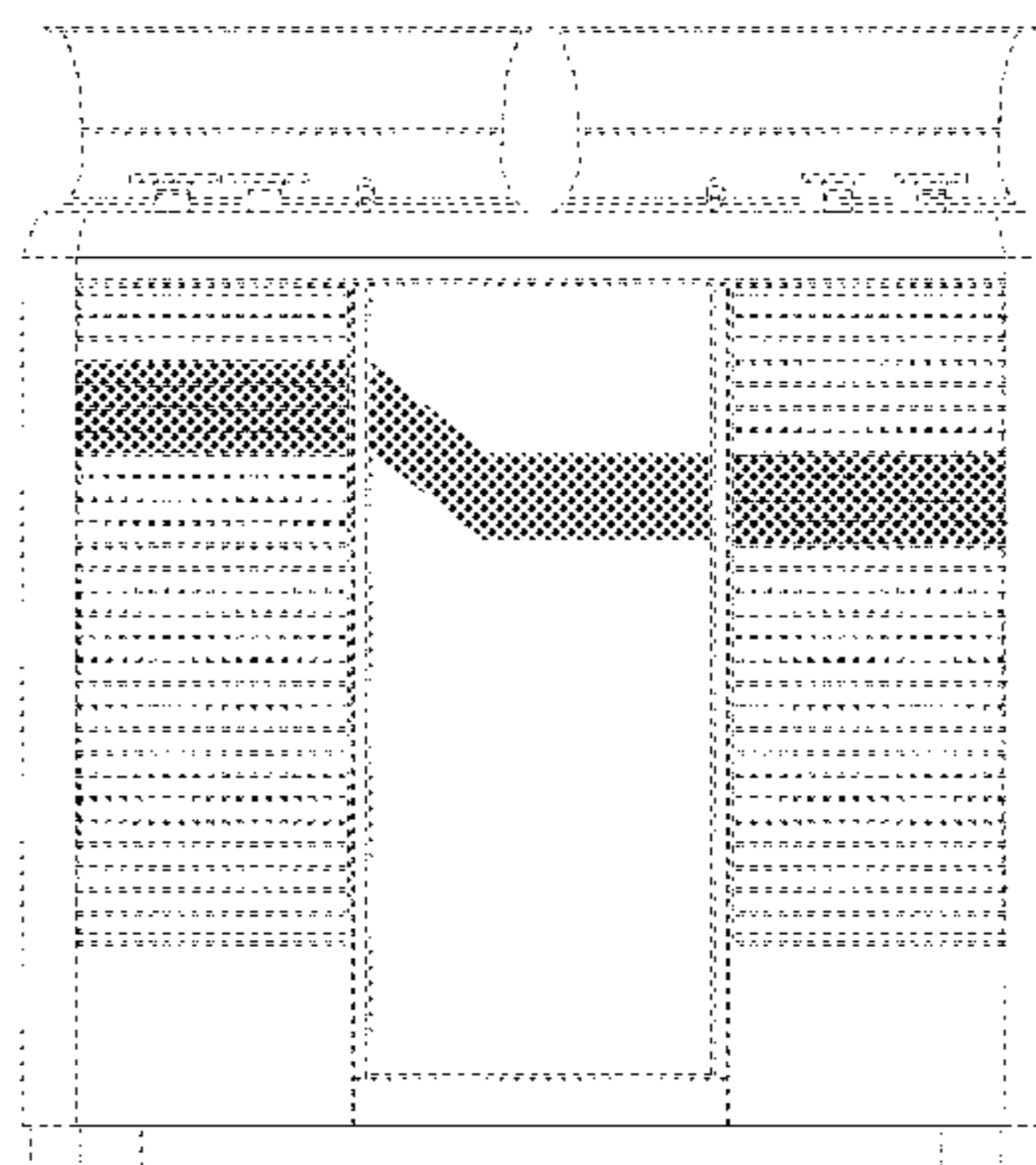
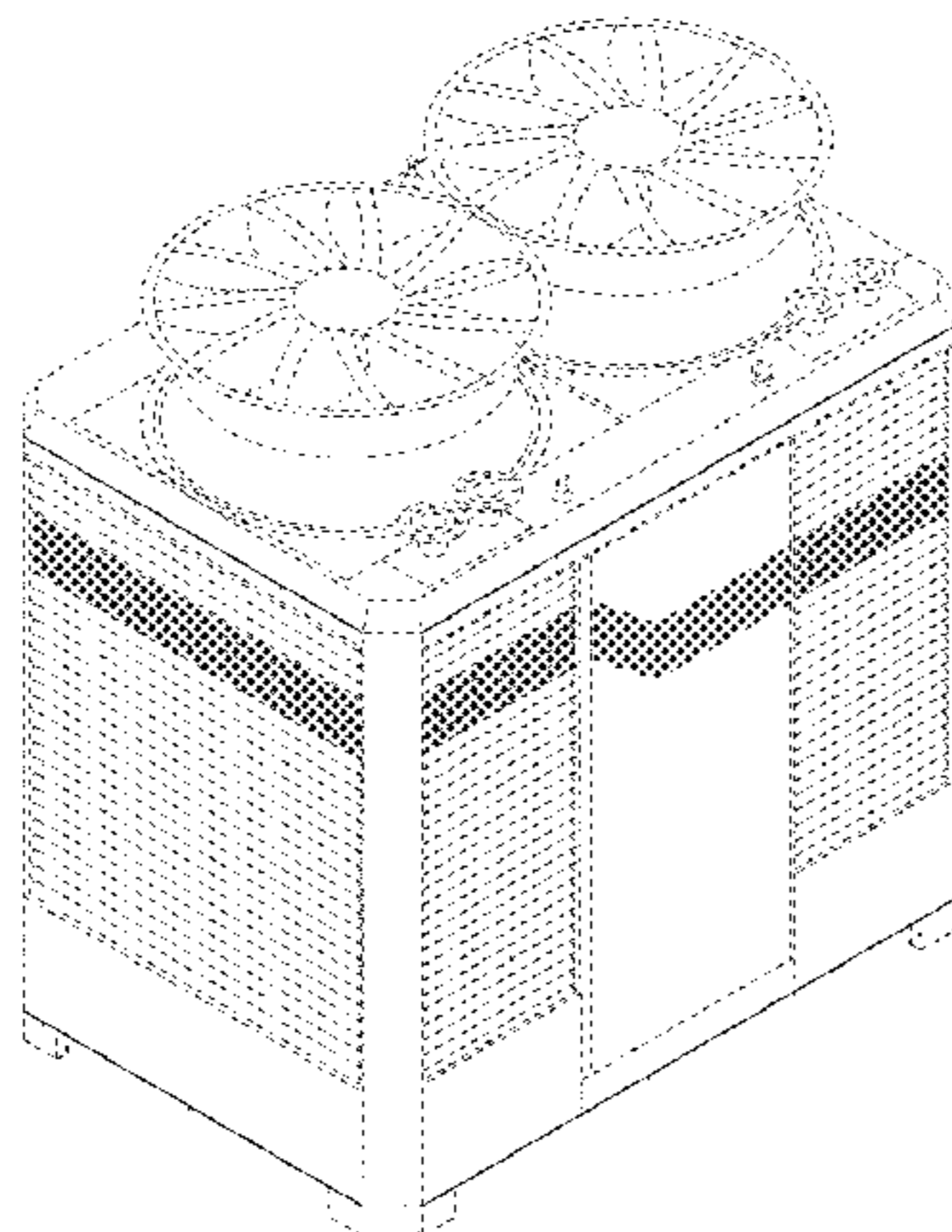

(56)

References Cited

U.S. PATENT DOCUMENTS

D706,215 S * 6/2014 Nakahira D13/110
D731,968 S * 6/2015 Peterson D13/110
D745,847 S * 12/2015 Ho D13/110
D751,033 S * 3/2016 Dessart D13/110
9,337,920 B2 * 5/2016 Chen H04B 7/24

OTHER PUBLICATIONS

Web.archive.org: Orcan e pack. Published Sep. 23, 2015. Retrieved from the internet at <<https://web.archive.org/web/20150923050029/http://www.orcan-energy.com/en/epack>>, Mar. 31, 2017. 1 page.*

* cited by examiner

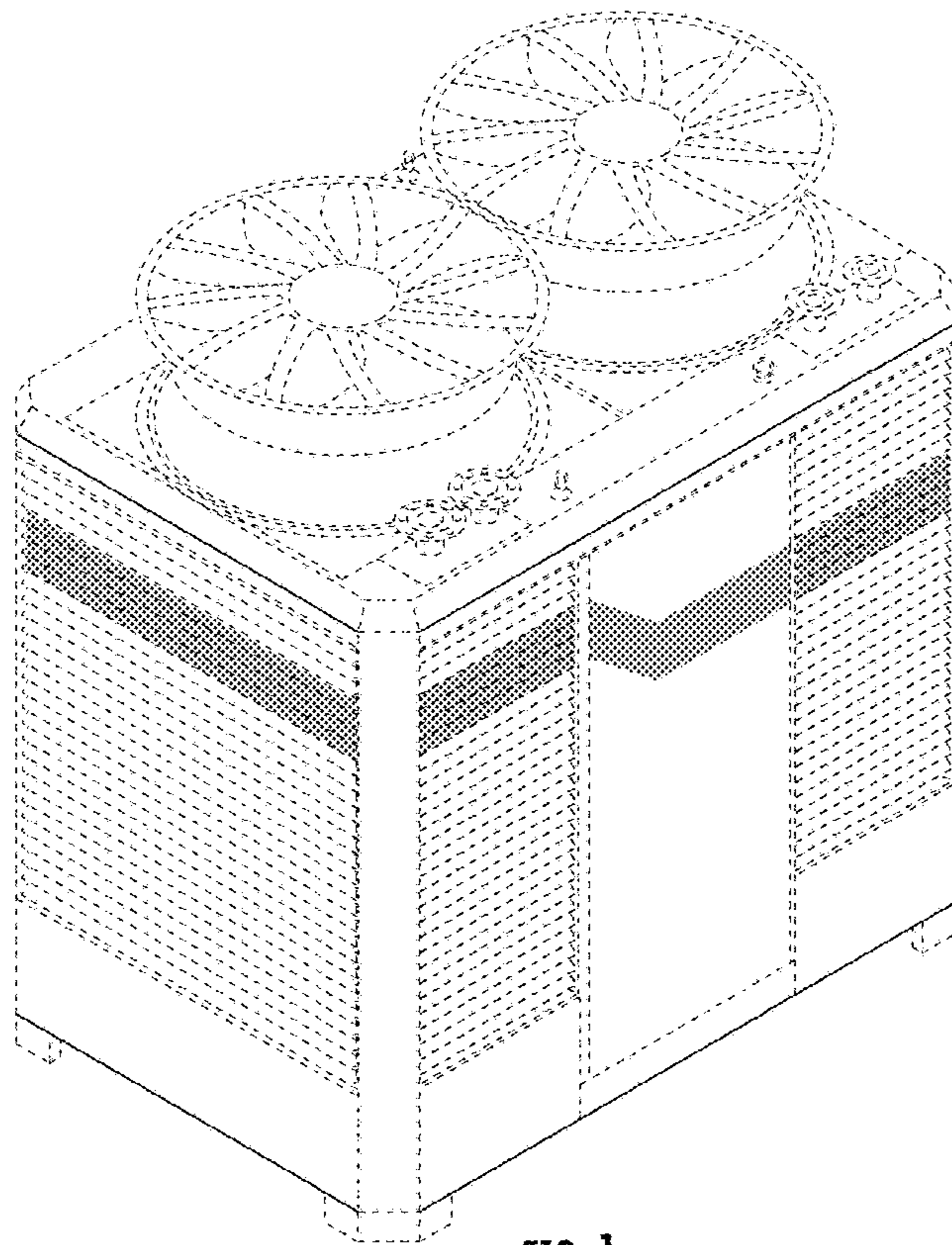

FIG. 1

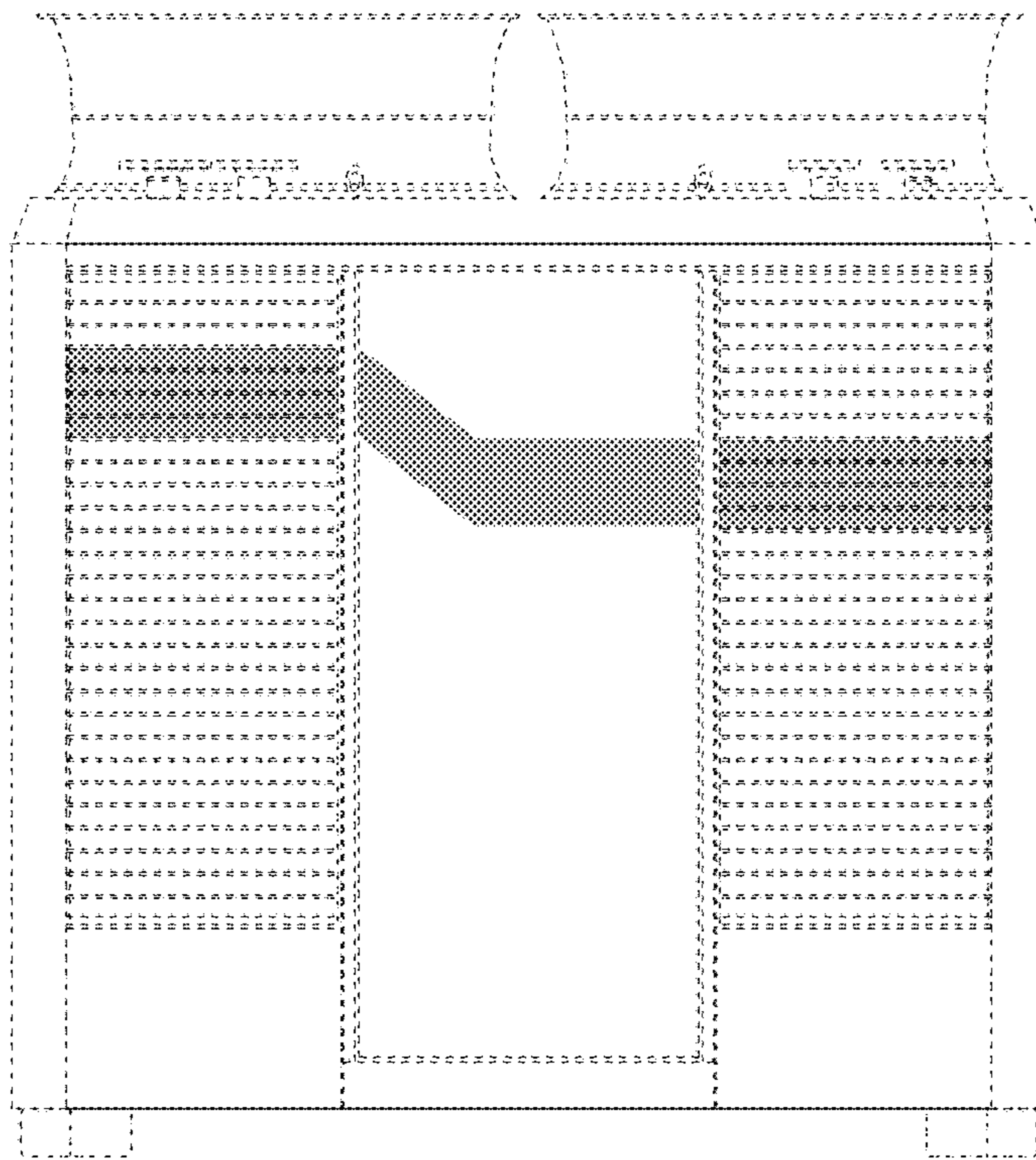

FIG. 2

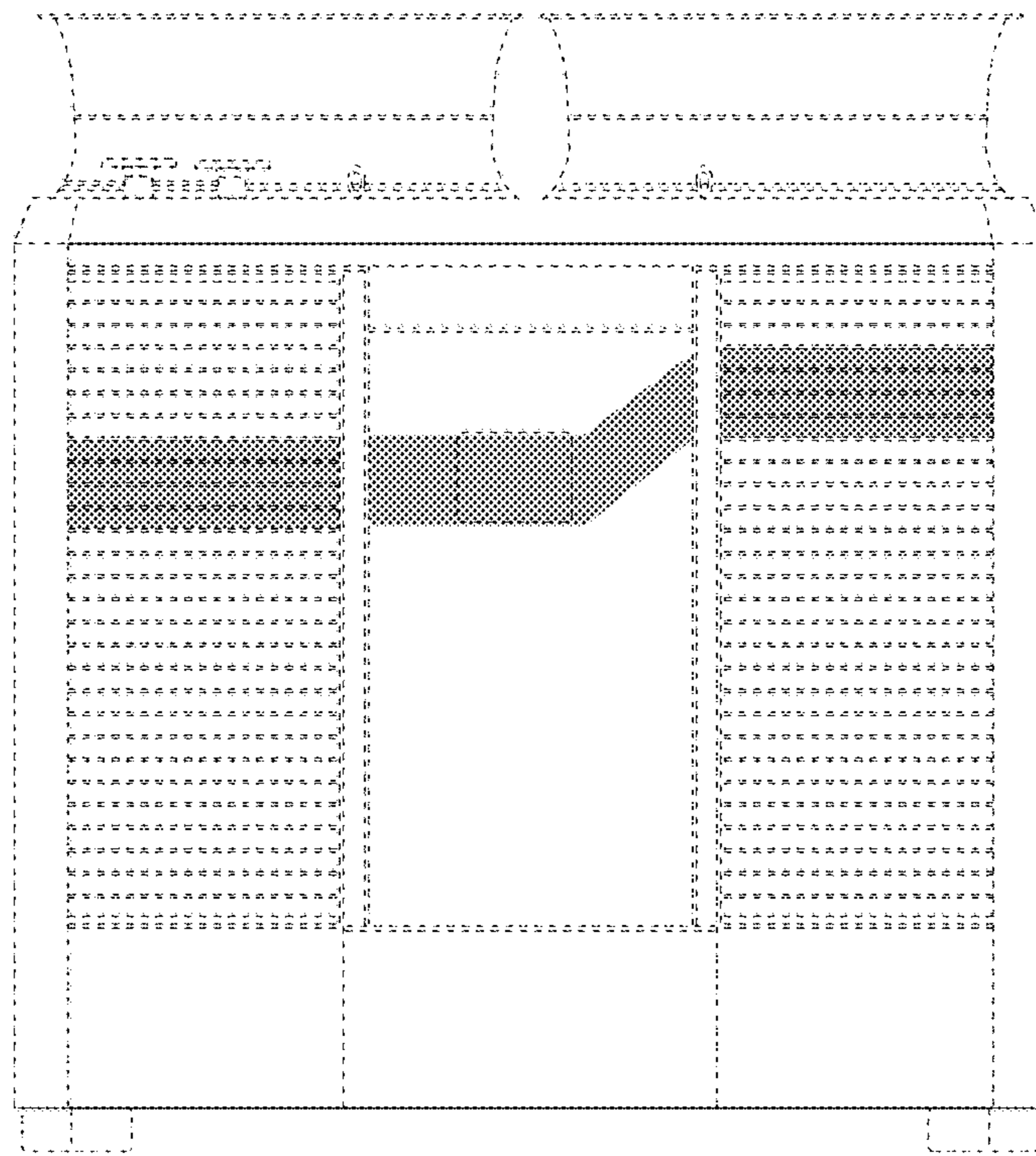

FIG. 3

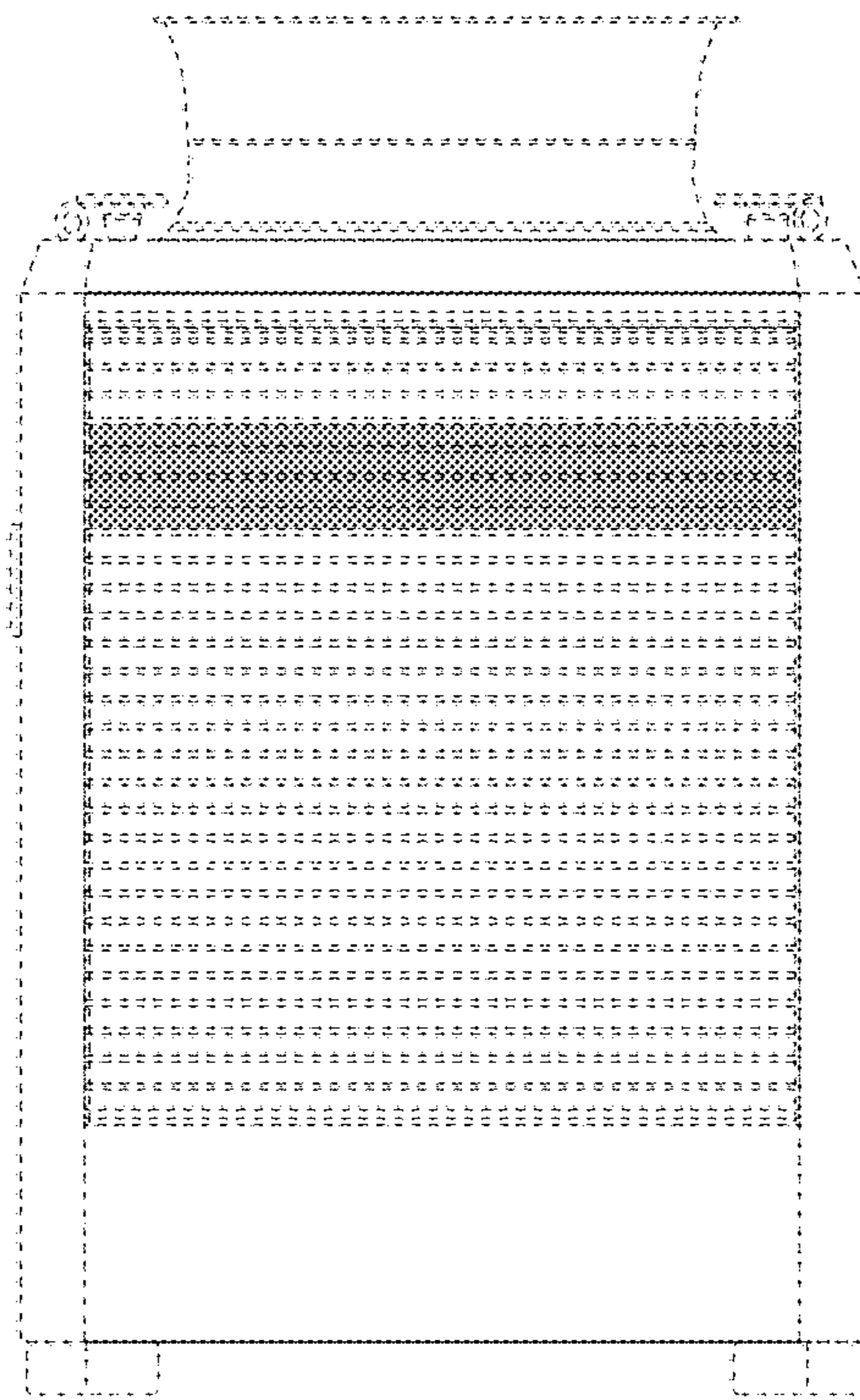

FIG. 4

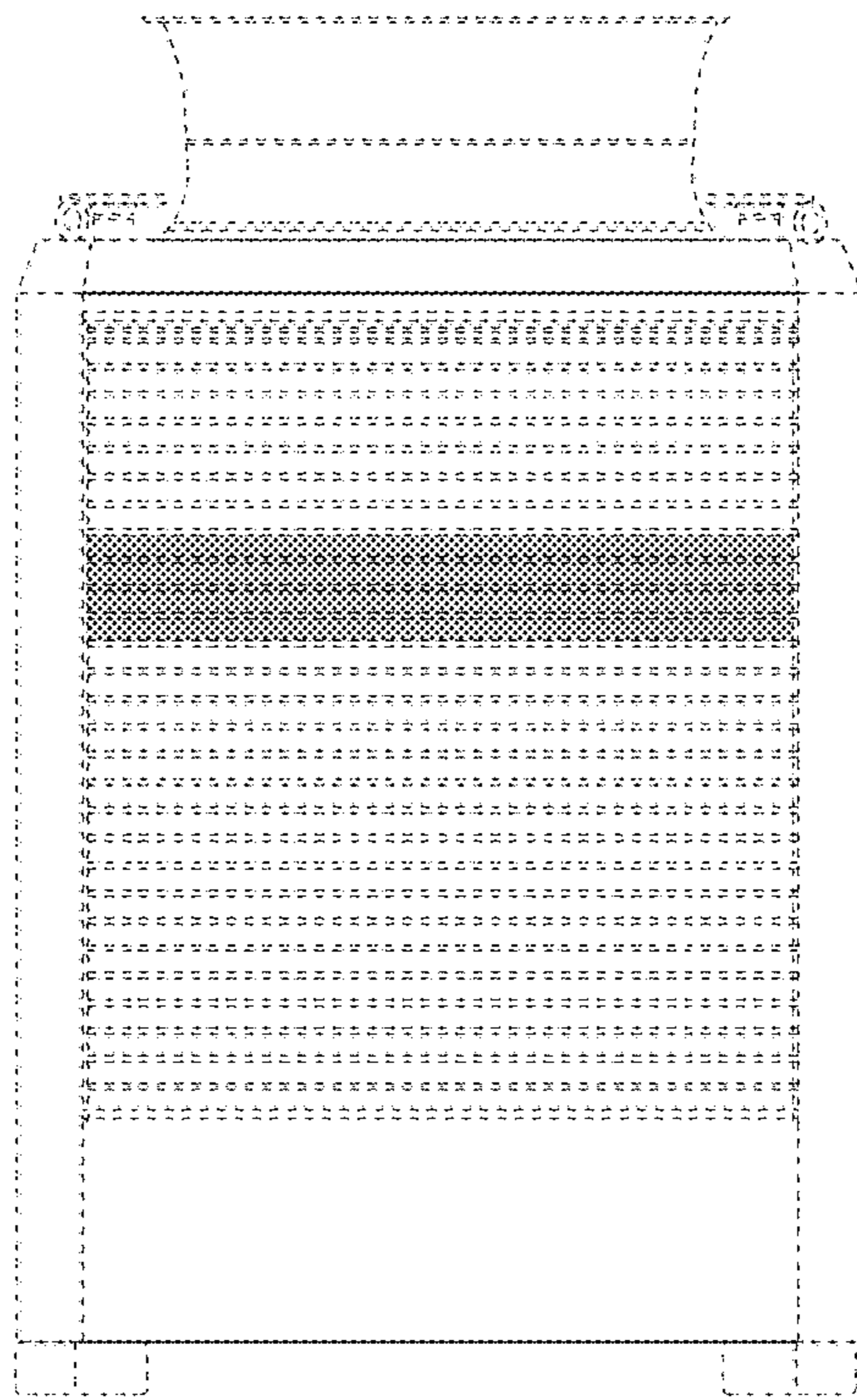

FIG. 5

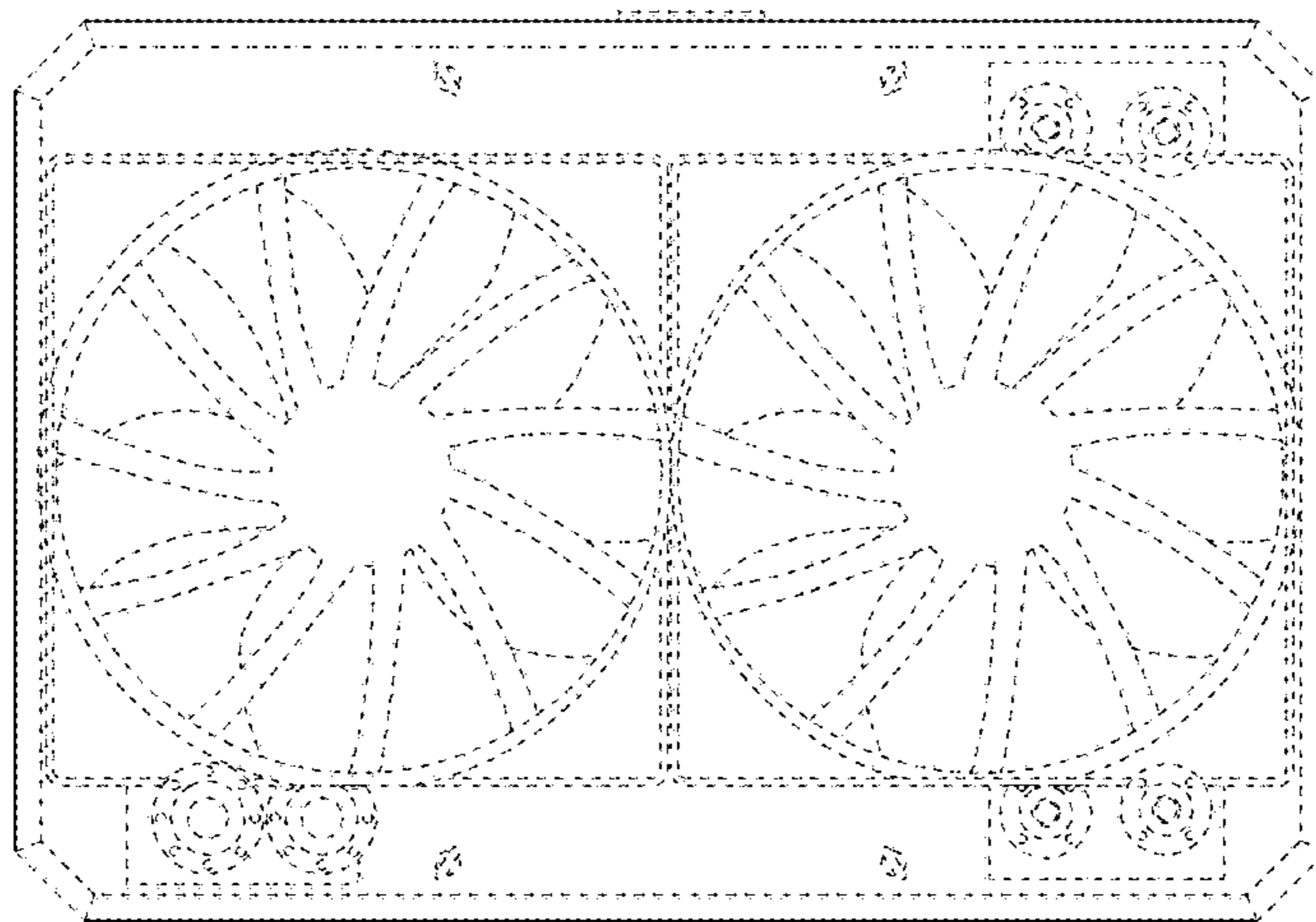

FIG. 6



FIG. 7