



US00D850344S

(12) **United States Design Patent**
DeMatthews

(10) **Patent No.:** **US D850,344 S**

(45) **Date of Patent:** **** Jun. 4, 2019**

- (54) **AUTOMOBILE DOOR BUMPER**
- (71) Applicant: **Lewis DeMatthews**, Brielle, NJ (US)
- (72) Inventor: **Lewis DeMatthews**, Brielle, NJ (US)
- (**) Term: **15 Years**
- (21) Appl. No.: **29/601,700**
- (22) Filed: **Apr. 25, 2017**
- (51) **LOC (11) Cl.** **12-08**
- (52) **U.S. Cl.**
USPC **D12/190; D12/401**
- (58) **Field of Classification Search**
USPC D12/86, 90, 91, 92, 110, 114, 163, 169,
D12/171, 190, 400; D11/11, 81, 133,
D11/157, 172, 211; D20/23, 24, 25, 30,
D20/31, 32
CPC ... G09F 7/00; G09F 7/02; G06K 9/325; B60P
3/36; B60R 13/10; B60R 13/105; B60R
19/44; B60Q 1/56
See application file for complete search history.

- 5,267,763 A * 12/1993 Klein B60R 13/04
248/206.5
- D386,458 S * 11/1997 Smith D12/167
- 6,318,045 B1 * 11/2001 Kress B60R 13/04
156/71
- D451,870 S * 12/2001 Hurayt D12/190
- D472,505 S * 4/2003 Hurayt D12/190
- D484,080 S * 12/2003 Yamamoto D12/190
- D613,220 S * 4/2010 Ikeda D12/190
- D660,755 S * 5/2012 Inoue D12/190

* cited by examiner

Primary Examiner — Darlington Ly

(74) *Attorney, Agent, or Firm* — Andrew G. Morabito,
Esq.

(57) **CLAIM**

The ornamental design for an automobile door bumper, as shown and described.

DESCRIPTION

FIG. 1 is a front perspective view of an automobile door bumper showing my new design;
 FIG. 2 is a top plan view thereof;
 FIG. 3 is a rear elevation view thereof;
 FIG. 4 is a side elevation view thereof;
 FIG. 5 is a front elevation view thereof;
 FIG. 6 is a rear elevation view thereof;
 FIG. 7 is a cross-sectional view thereof taken along line 7-7 in FIG. 3; and,
 FIG. 8 is a perspective view thereof when attached to an automobile.
 The broken line showing portions of an automobile is provided for the purpose of illustrating environmental structure and form no part of the claimed design.

1 Claim, 3 Drawing Sheets

(56) **References Cited**

U.S. PATENT DOCUMENTS

- D160,548 S * 10/1950 Sheard D12/190
- D176,259 S * 12/1955 Holls D12/190
- D183,103 S * 6/1958 Mackichan D12/190
- 3,659,887 A * 5/1972 Marquette B60R 13/04
293/120
- D281,412 S * 11/1985 Barnhart D12/190
- D313,862 S * 1/1991 Gaukler D12/190
- 5,063,014 A * 11/1991 Cakmakci B29C 31/045
264/151
- D329,632 S * 9/1992 Masters D12/190

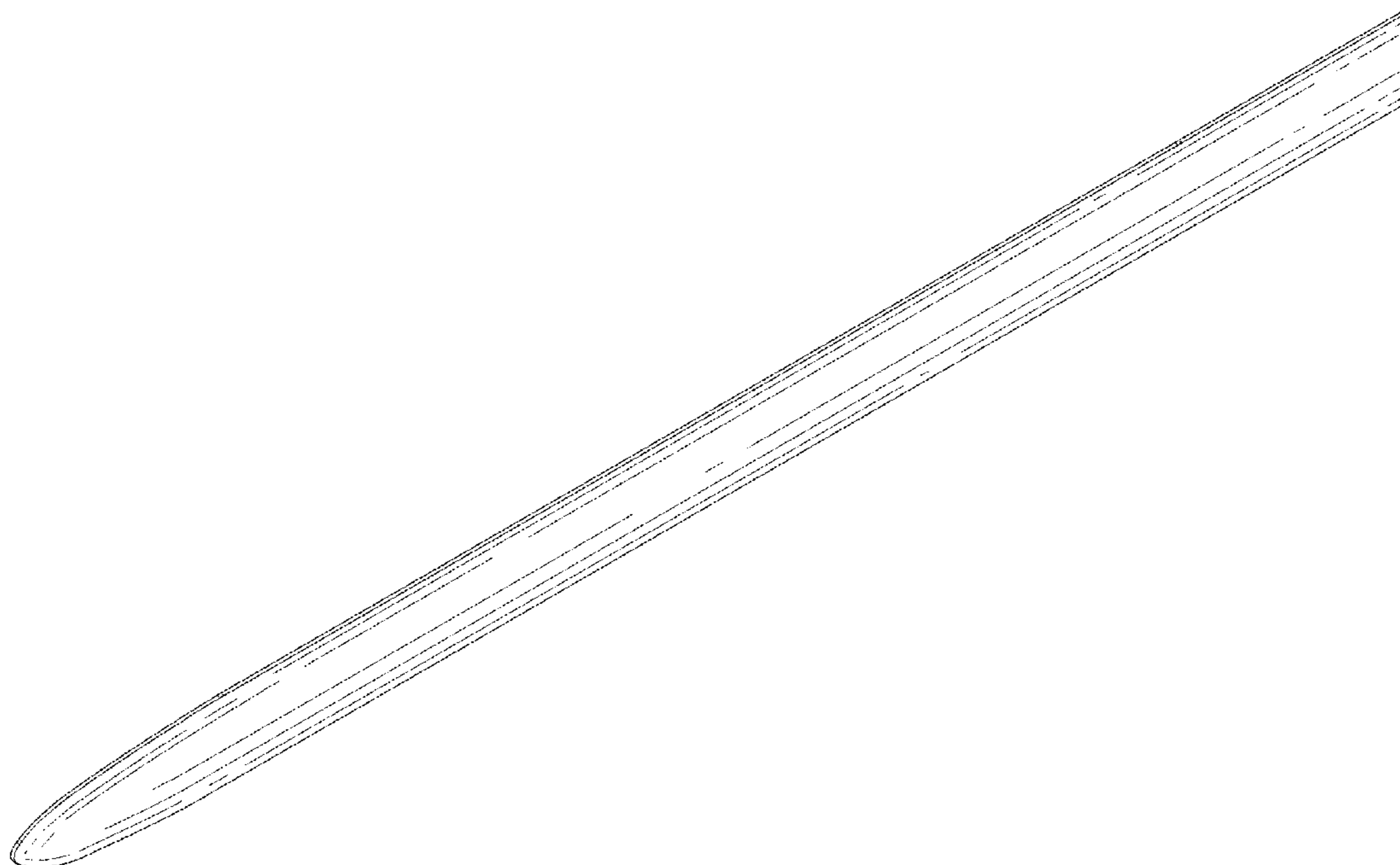

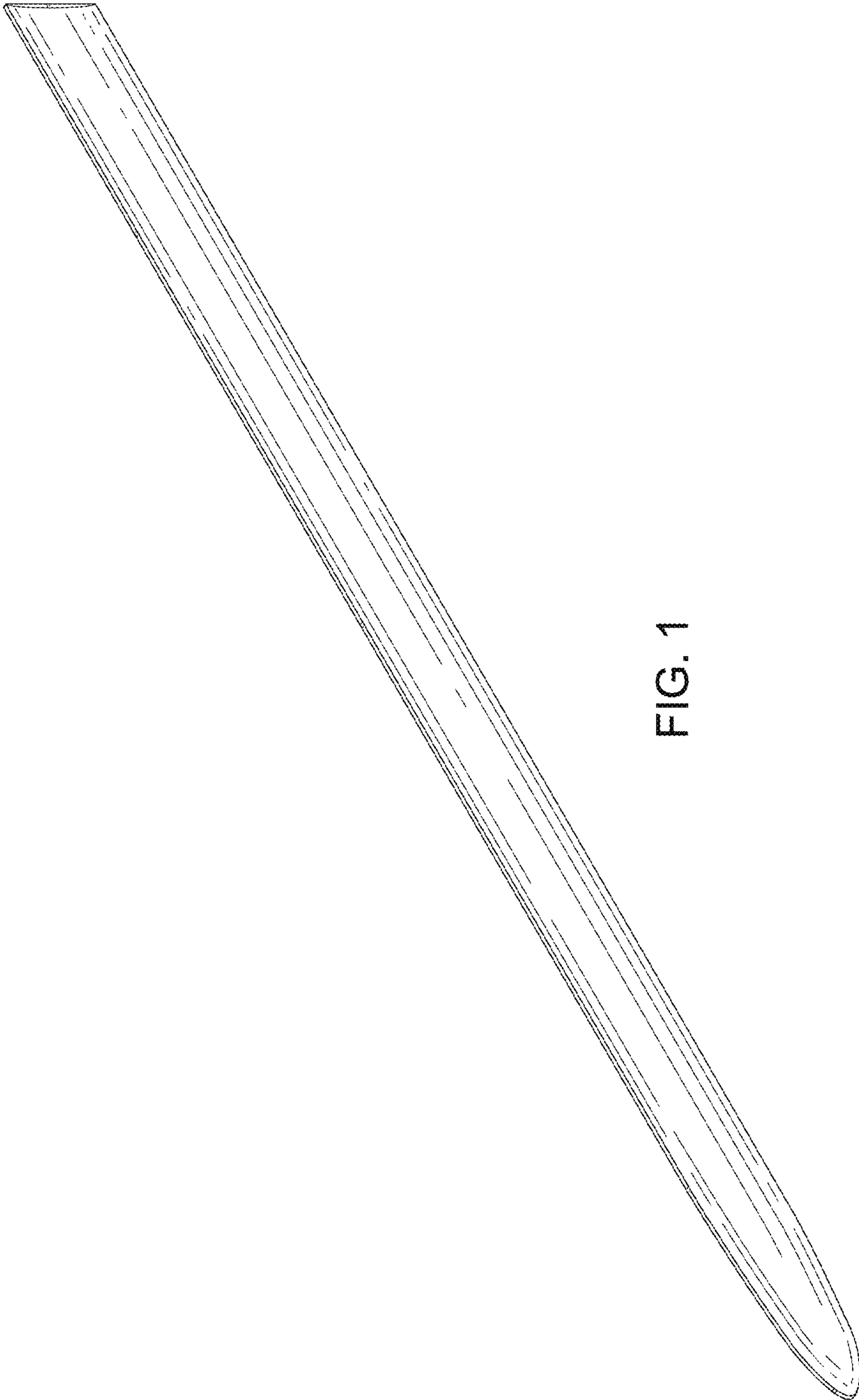

FIG. 1



FIG. 2

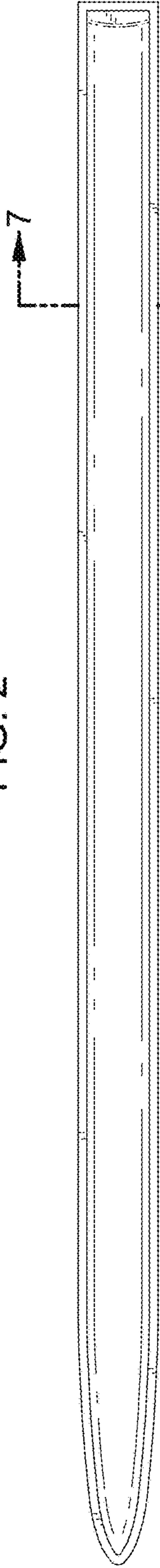

FIG. 3

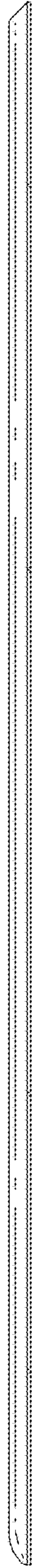

FIG. 4

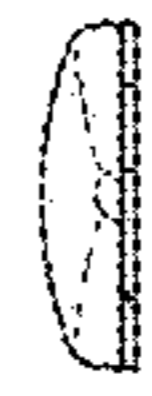

FIG. 5

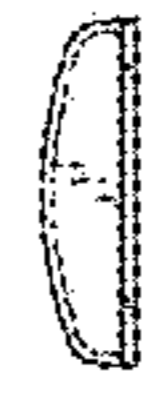

FIG. 6

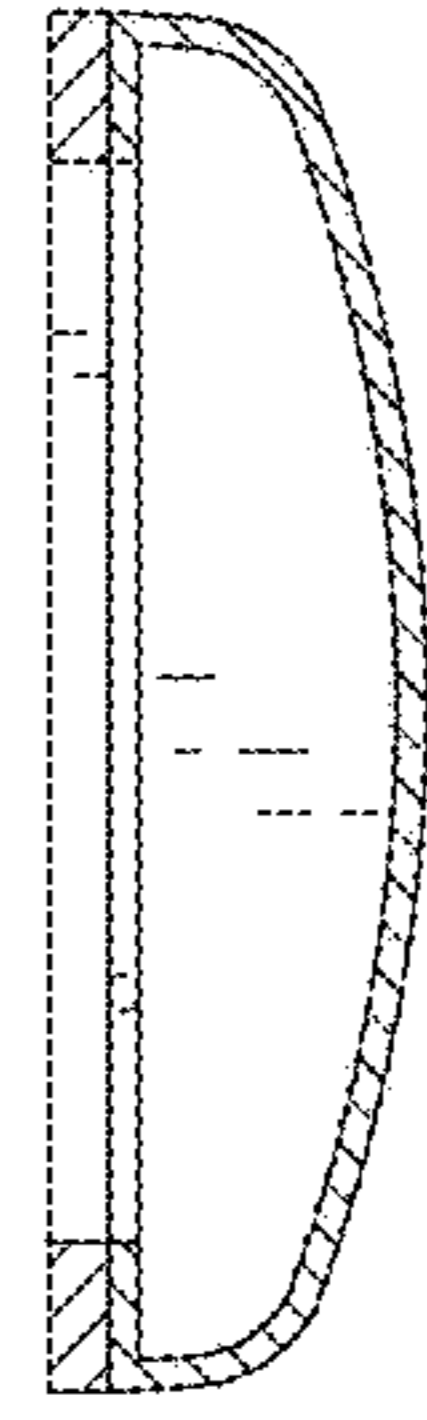

FIG. 7

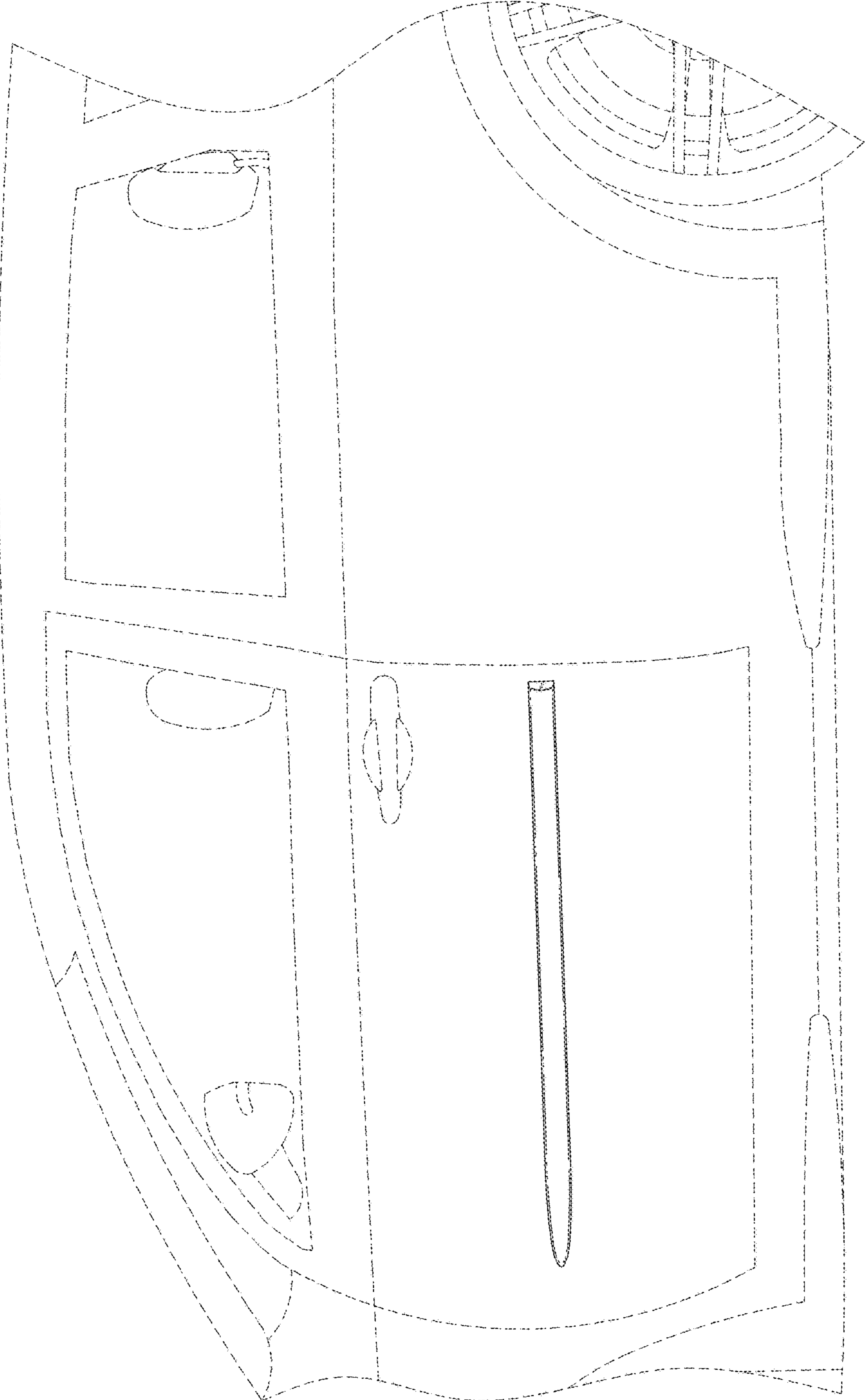

FIG. 8