



US00D849963S

(12) **United States Design Patent** (10) **Patent No.:** **US D849,963 S**
Bulloch et al. (45) **Date of Patent:** **** May 28, 2019**

- (54) **ELECTROPHORESIS GEL CASSETTE**
- (71) Applicant: **LIFE TECHNOLOGIES CORPORATION**, Carlsbad, CA (US)
- (72) Inventors: **Kyle Bulloch**, San Diego, CA (US);
Thomas Diller, San Diego, CA (US);
Xin Mathers, Poway, CA (US)
- (73) Assignee: **LIFE TECHNOLOGIES CORPORATION**, Carlsbad, CA (US)
- (**) Term: **15 Years**
- (21) Appl. No.: **29/545,620**
- (22) Filed: **Nov. 13, 2015**
- (51) **LOC (11) Cl.** **24-99**
- (52) **U.S. Cl.**
USPC **D24/233**
- (58) **Field of Classification Search**
USPC D24/232-233; D10/81

(Continued)

(56) **References Cited**

U.S. PATENT DOCUMENTS

3,888,759 A 6/1975 Elson
4,294,684 A 10/1981 Serwer

(Continued)

FOREIGN PATENT DOCUMENTS

WO 1995024640 9/1995
WO 1999054721 10/1999
WO 2007032951 3/2007

OTHER PUBLICATIONS

Caprette, D. "Characterization of red cell membrane proteins by SDS-Page—Preparing SDS Gels," <http://www.ruf.rice.edu/~bioslabs/studies/sds-page/gellab2a.html>, updated May 24, 2005, downloaded Jan. 2, 2017, pp. 1-5.

(Continued)

Primary Examiner — Vy N Koenig

(57) **CLAIM**

The ornamental design for an electrophoresis gel cassette, as shown and described.

DESCRIPTION

This application is related to U.S. Design patent application Ser. No. 29/545,629 filed Nov. 13, 2015, entitled "Electrophoresis Gel Cassette and Sample Loading Guide"; and to U.S. Design patent application Ser. No. 29/545,637 filed Nov. 13, 2015, entitled "Rig for Electrophoresis Gel Casting", the entire contents of each of which are incorporated by reference herein.

FIG. 1 is a front perspective view of an embodiment of an electrophoresis gel cassette showing our new design.

FIG. 2 is back perspective view thereof.

FIG. 3 is a front view thereof.

FIG. 4 is a back view thereof.

FIG. 5 is a right side view thereof.

FIG. 6 is a left side view thereof.

FIG. 7 is a top view thereof.

FIG. 8 is a bottom view thereof.

FIG. 9 is a front perspective view of another embodiment of an electrophoresis gel cassette showing our new design.

FIG. 10 is a back perspective thereof.

FIG. 11 is a front view thereof.

FIG. 12 is a back view thereof.

FIG. 13 is a right side view thereof.

FIG. 14 is a left side view thereof.

FIG. 15 is a top view thereof.

FIG. 16 is a bottom view thereof.

FIG. 17 is a front perspective view of another embodiment of an electrophoresis gel cassette showing our new design.

FIG. 18 is a back perspective thereof.

FIG. 19 is a front view thereof.

FIG. 20 is a back view thereof.

FIG. 21 is a right side view thereof.

FIG. 22 is a left side view thereof.

FIG. 23 is a top view thereof.

FIG. 24 is a bottom view thereof.

FIG. 25 is a front perspective view of another embodiment of an electrophoresis gel cassette showing our new design.

(Continued)

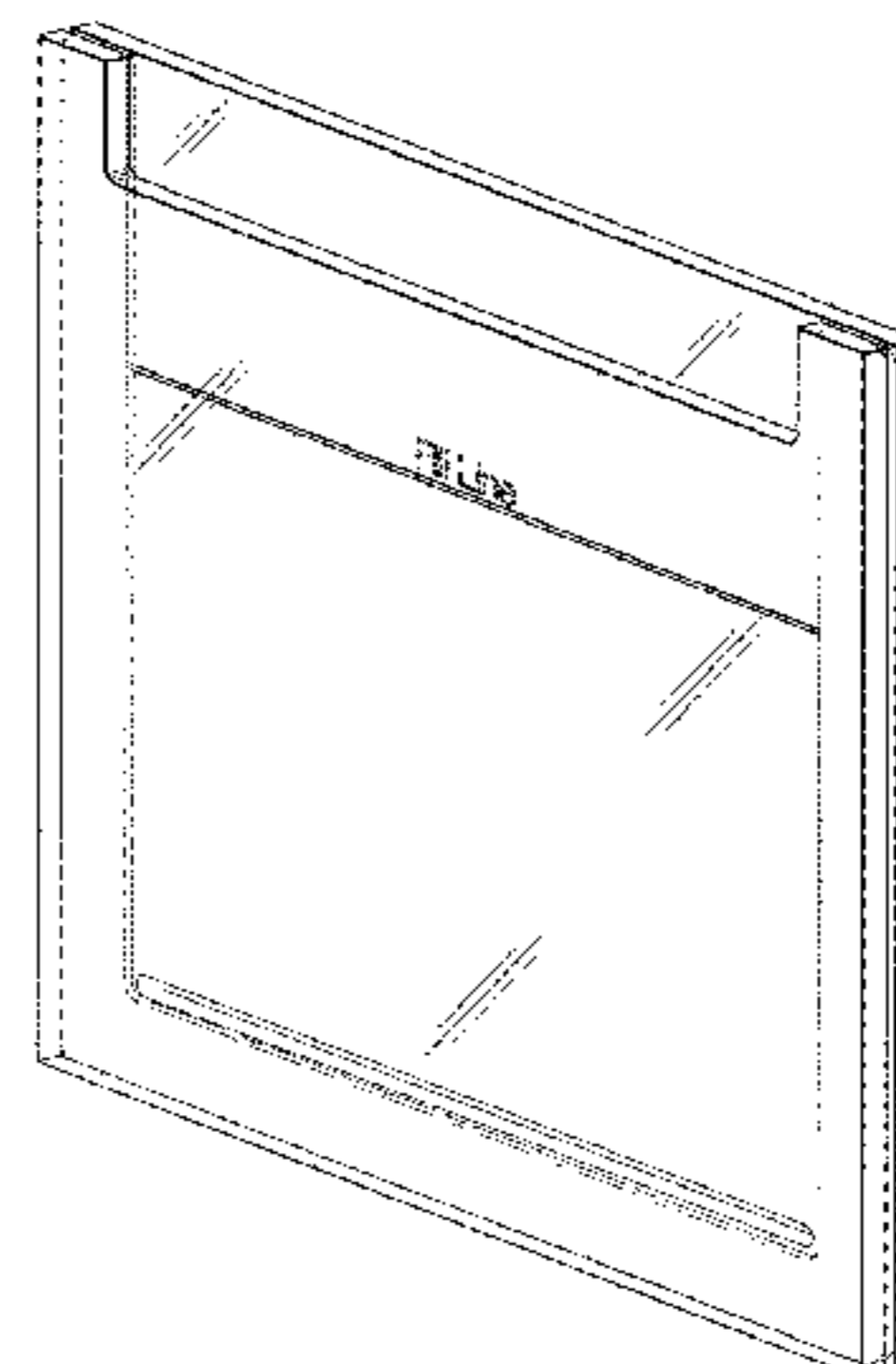
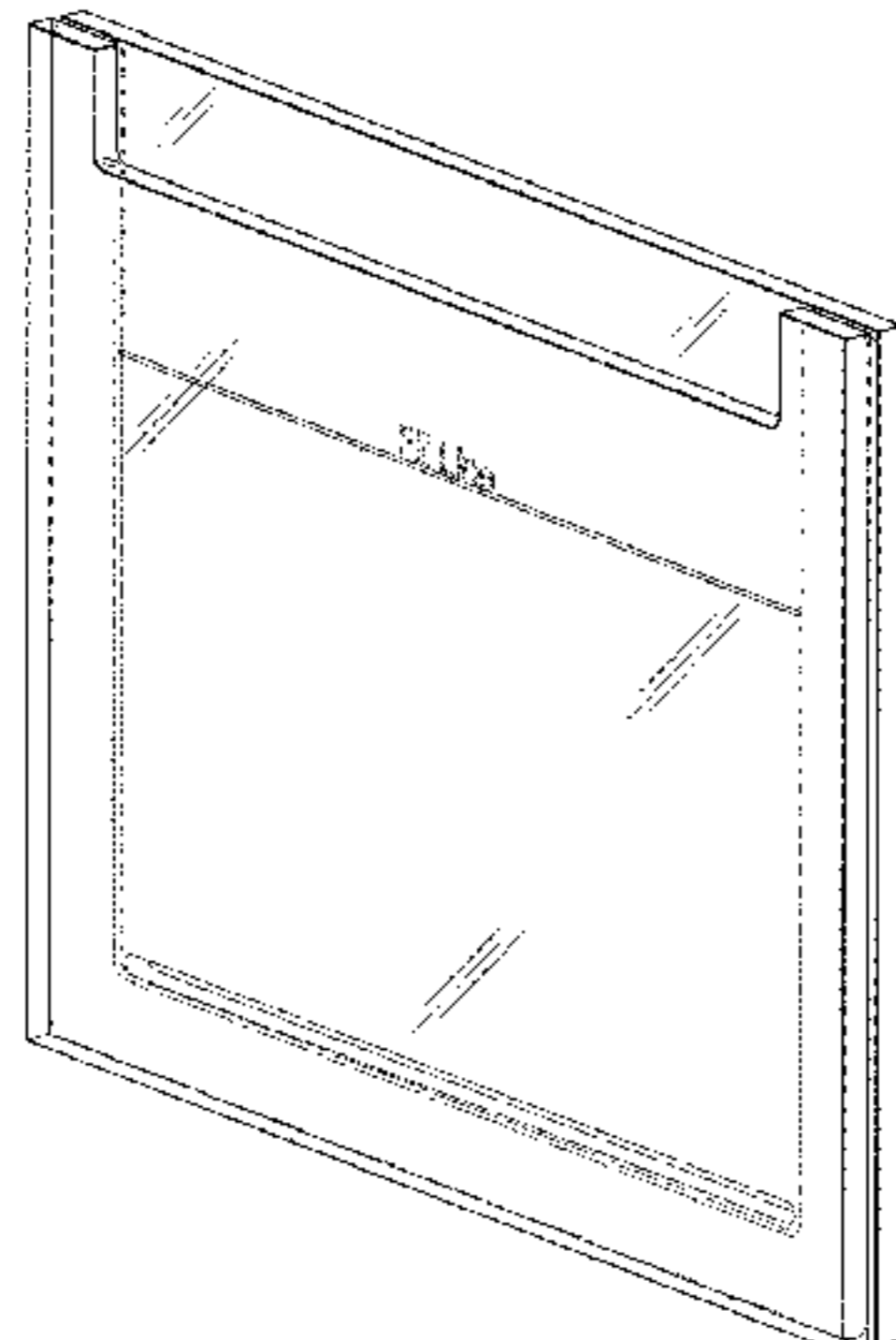

FIG. 26 is back perspective view thereof.
 FIG. 27 is a front view thereof.
 FIG. 28 is a back view thereof.
 FIG. 29 is a right side view thereof.
 FIG. 30 is a left side view thereof.
 FIG. 31 is a top view thereof; and,
 FIG. 32 is a bottom view thereof.
 The broken lines in the figures show unclaimed portions of the electrophoresis gel cassette and form no part of the claimed design.
 The short diagonal shade lines in the figures depict the contours and transparent qualities of the surface upon which they are applied and not surface ornamentation.
 The elements on one side of the electrophoresis gel cassette may, therefore, be seen through the electrophoresis gel cassette from the opposite side of the electrophoresis gel cassette. Elements viewed directly on a surface of the electrophoresis gel cassette are shown in heavier lines than elements seen through the electrophoresis gel cassette.

1 Claim, 20 Drawing Sheets

(58) **Field of Classification Search**

CPC G01N 27/44704; G01N 27/44743; G01N 27/44747; G01N 27/44756; G01N 27/44778; C07K 1/26

See application file for complete search history.

(56) **References Cited**

U.S. PATENT DOCUMENTS

D269,123 S 5/1983 Hoefer
 4,560,459 A * 12/1985 Hoefer G01N 27/44704
 204/467
 4,574,040 A 3/1986 Delony et al.
 4,693,804 A 9/1987 Serwer
 4,715,942 A * 12/1987 Tezuka G01N 27/44756
 204/618
 4,772,373 A 9/1988 Ebata et al.
 4,773,984 A 9/1988 Flesher et al.
 4,795,541 A 1/1989 Hurd
 D303,007 S 8/1989 Flesher et al.
 4,957,613 A 9/1990 Schuette
 4,975,174 A 12/1990 Bambeck
 5,073,246 A 12/1991 Chu
 5,116,483 A 5/1992 Lander
 5,192,408 A * 3/1993 Scott G01N 27/44704
 204/470
 5,228,971 A 7/1993 Brumley et al.
 5,238,651 A 8/1993 Chuba
 5,284,565 A 2/1994 Chu
 5,292,420 A 3/1994 Nakanura et al.
 5,407,552 A 4/1995 Lebacq
 D367,713 S 3/1996 La Motte
 5,618,399 A 4/1997 Gautsch
 5,626,735 A 5/1997 Chu
 5,632,877 A 5/1997 Van et al.
 5,685,967 A * 11/1997 Manis G01N 27/44756
 204/606
 5,753,095 A 5/1998 Alpenfels
 5,773,645 A * 6/1998 Hochstrasser ... G01N 27/44773
 204/456

5,827,418 A * 10/1998 Haven G01N 27/44704
 204/618
 5,843,295 A 12/1998 Steiner
 5,885,431 A 3/1999 Renfrew et al.
 5,888,369 A 3/1999 Tippins
 5,972,188 A 10/1999 Rice
 5,989,403 A * 11/1999 Provonchee G01N 27/44704
 204/618
 6,001,233 A 12/1999 Levy et al.
 6,027,628 A * 2/2000 Yamamura G01N 27/44704
 204/461
 6,110,340 A 8/2000 Lau et al.
 6,110,344 A 8/2000 Renfrew
 6,139,709 A 10/2000 Scott
 D443,068 S * 5/2001 Manus D24/233
 6,231,741 B1 * 5/2001 Tuurenhout G01N 27/44704
 204/618
 6,379,519 B1 * 4/2002 Sevigny B29C 51/30
 204/620
 6,436,262 B1 8/2002 Perez et al.
 6,521,111 B1 * 2/2003 Amshey G01N 27/44704
 204/600
 D505,729 S 5/2005 Lee
 6,929,732 B2 8/2005 Chen
 6,932,895 B2 8/2005 Anderson
 6,936,150 B2 8/2005 Rooney et al.
 6,942,775 B1 9/2005 Fox et al.
 D510,770 S 10/2005 Emerson
 D511,386 S * 11/2005 Emerson D24/233
 6,969,455 B1 11/2005 Helfer et al.
 D524,449 S * 7/2006 Emerson D24/233
 7,276,143 B2 10/2007 Chen et al.
 7,601,251 B2 * 10/2009 Rooney C07K 1/26
 204/456
 7,749,367 B2 7/2010 Zhou et al.
 D654,597 S 2/2012 Hiramura
 8,361,294 B2 1/2013 Wang
 8,398,838 B2 3/2013 Chen et al.
 8,449,745 B2 5/2013 Wang
 8,480,874 B2 * 7/2013 Henry C07K 1/26
 204/600
 D719,277 S 12/2014 Miller
 D733,922 S * 7/2015 Sjolander D20/40
 9,234,874 B2 * 1/2016 Panattoni G01N 27/44704
 D757,958 S 5/2016 Murray et al.
 9,383,335 B2 * 7/2016 Bjorkesten G01N 27/44704
 9,400,260 B2 7/2016 Suh
 D792,603 S 7/2017 Bulloch et al.
 9,714,918 B2 * 7/2017 Updyke G01N 27/44778
 D794,823 S 8/2017 Nelson
 D795,449 S * 8/2017 Miller D24/233
 D806,894 S 1/2018 Nelson
 2002/0079222 A1 6/2002 Sevigny
 2006/0163067 A1 7/2006 Sevigny
 2006/0278533 A1 12/2006 Chen
 2007/0205108 A1 9/2007 Tzu-Chao et al.
 2007/0284250 A1 12/2007 Magnant
 2011/0042213 A1 2/2011 Updyke
 2011/0042217 A1 2/2011 Updyke et al.
 2014/0045250 A1 2/2014 Kreifels et al.
 2016/0041123 A1 2/2016 Guadagno
 2016/0084797 A1 3/2016 Goh et al.
 2017/0153204 A1 * 6/2017 Bulloch G01N 27/44704

OTHER PUBLICATIONS

D. R. Caprette, "Preparing SDS Gels", URL: <https://web.archive.org/web/20051030035520/http://www.ruf.rice.edu/-bioslabs/studies/sds-page/gellab2a.html>, 5 pages, published Oct. 30 (Year: 2005).

* cited by examiner

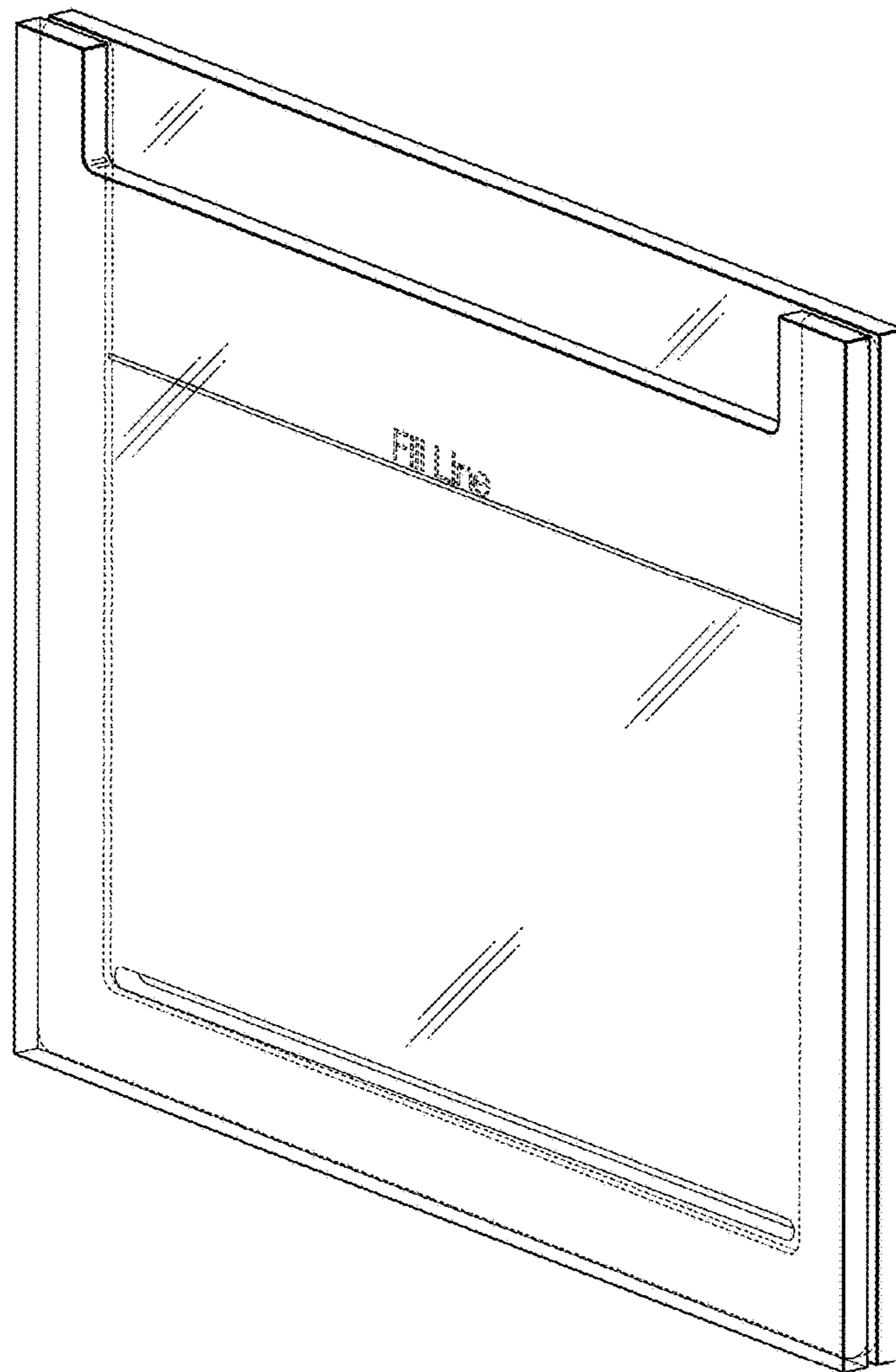

FIG. 1

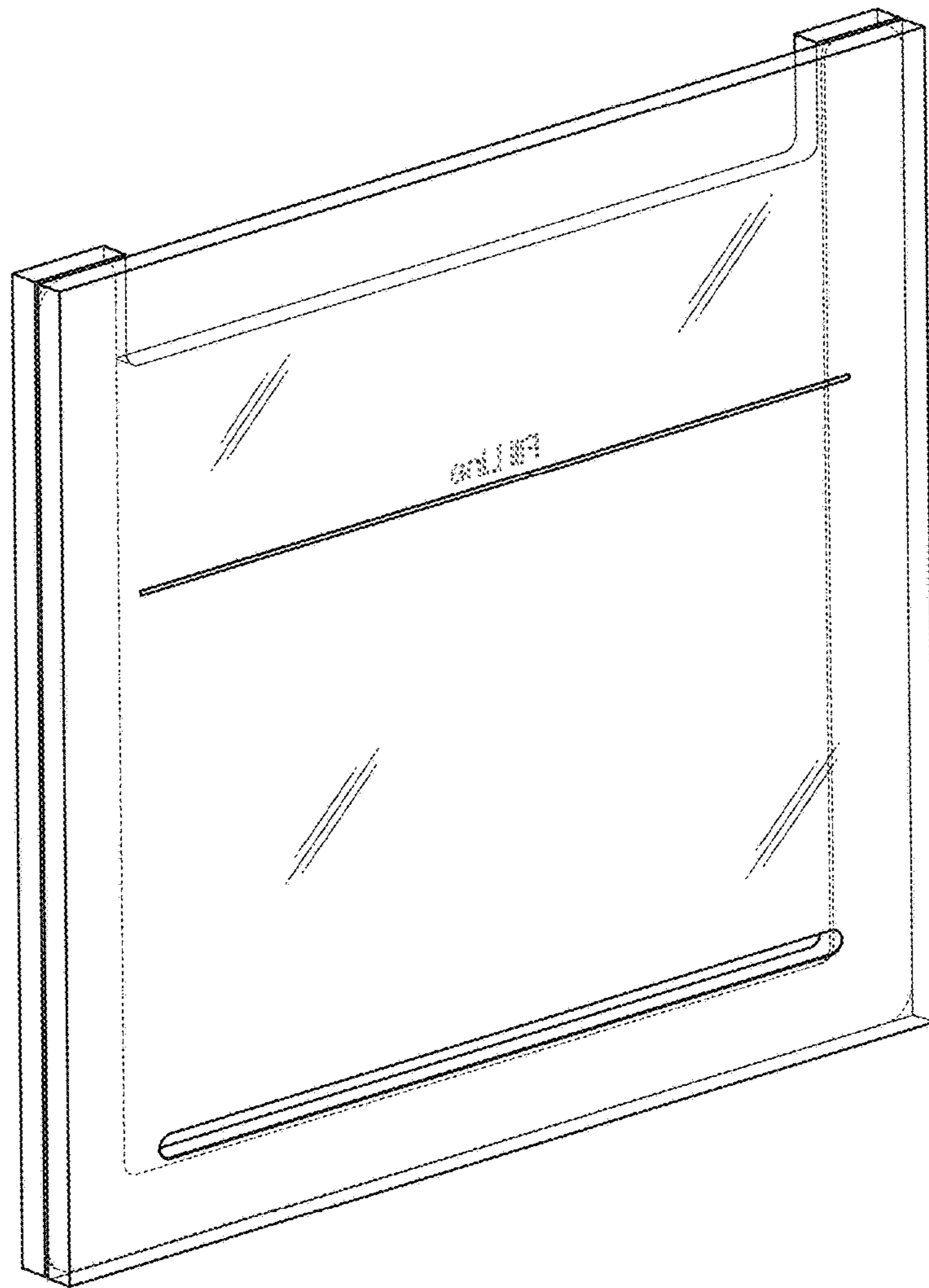

FIG. 2

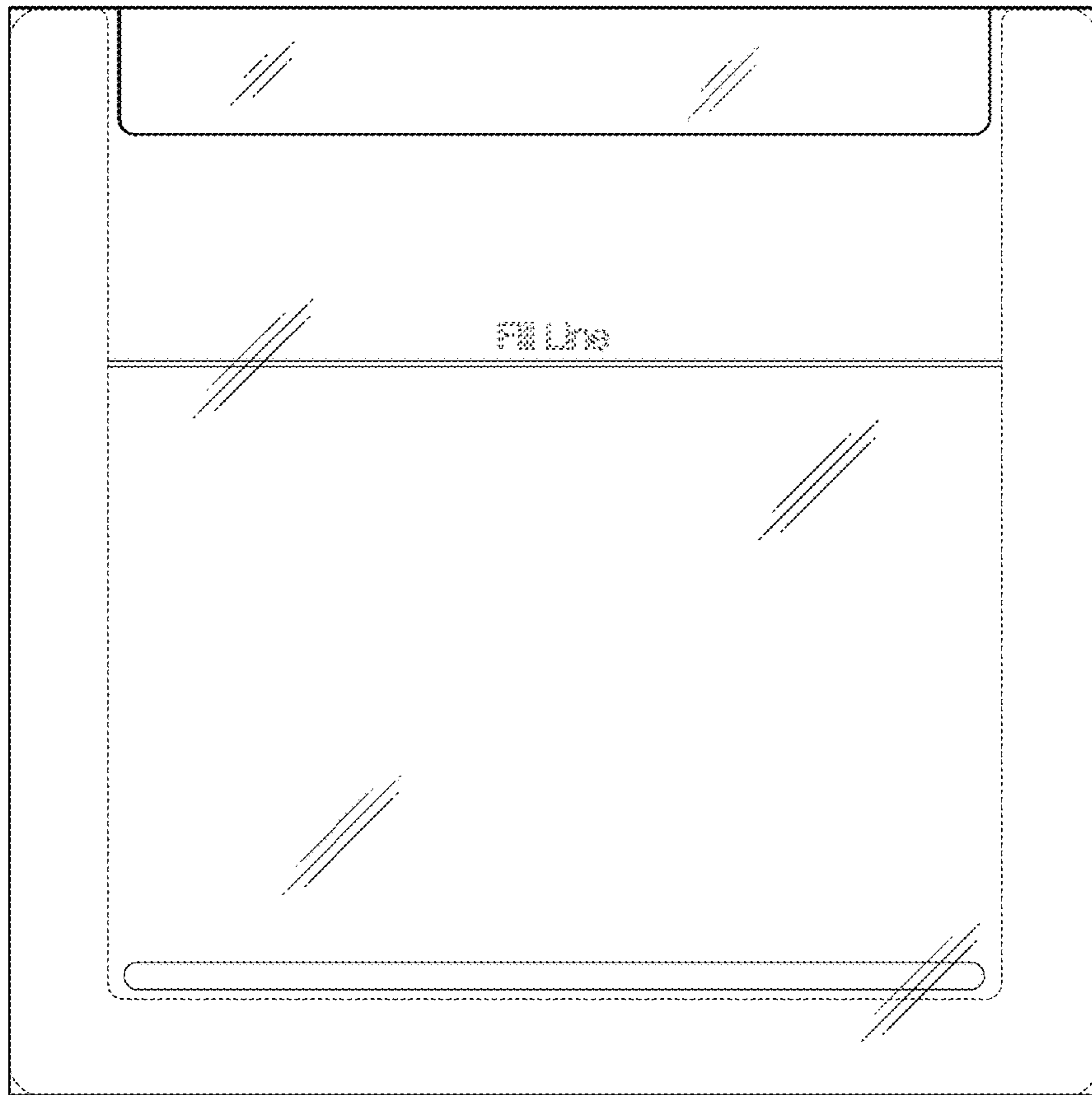

FIG. 3

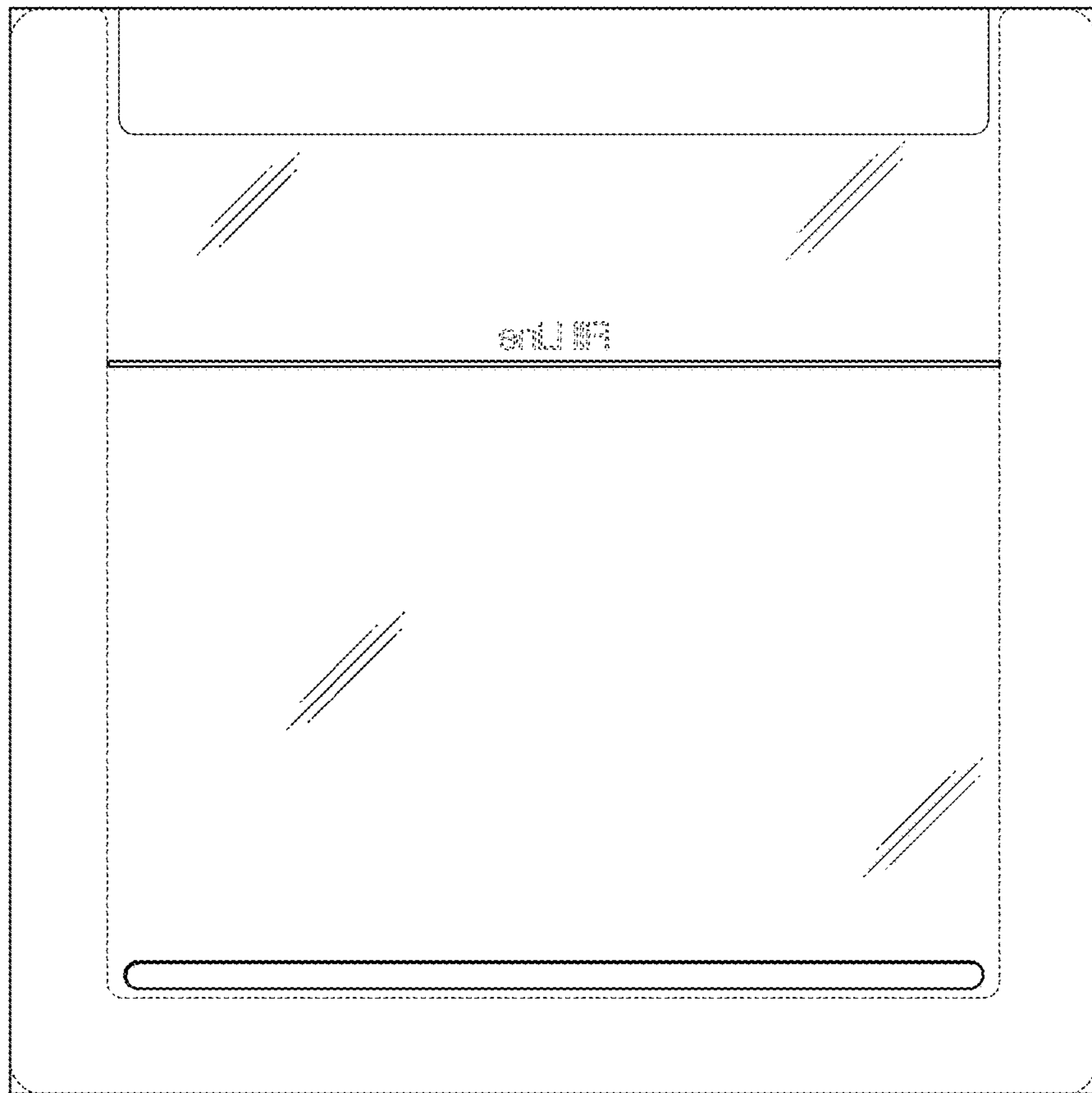

FIG. 4

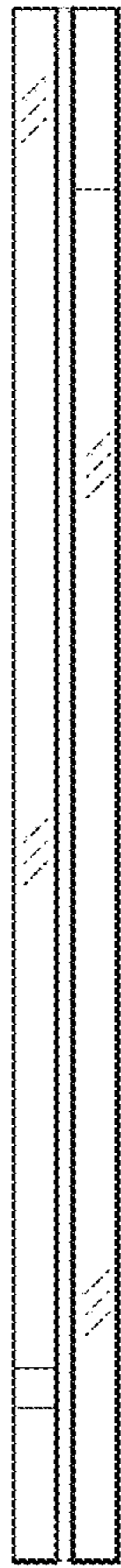

FIG. 5

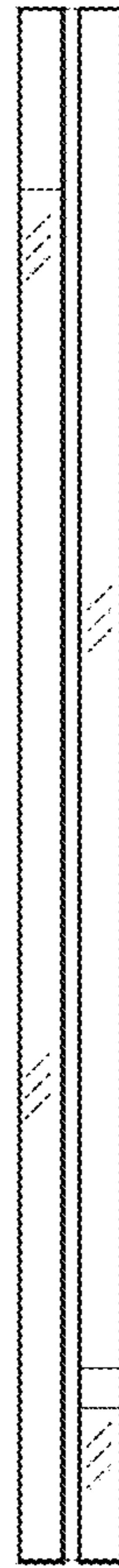

FIG. 6



FIG. 7

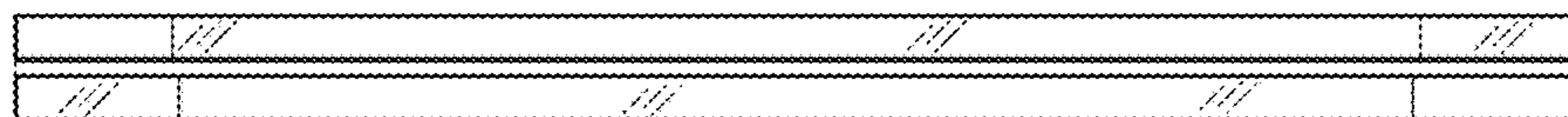

FIG. 8

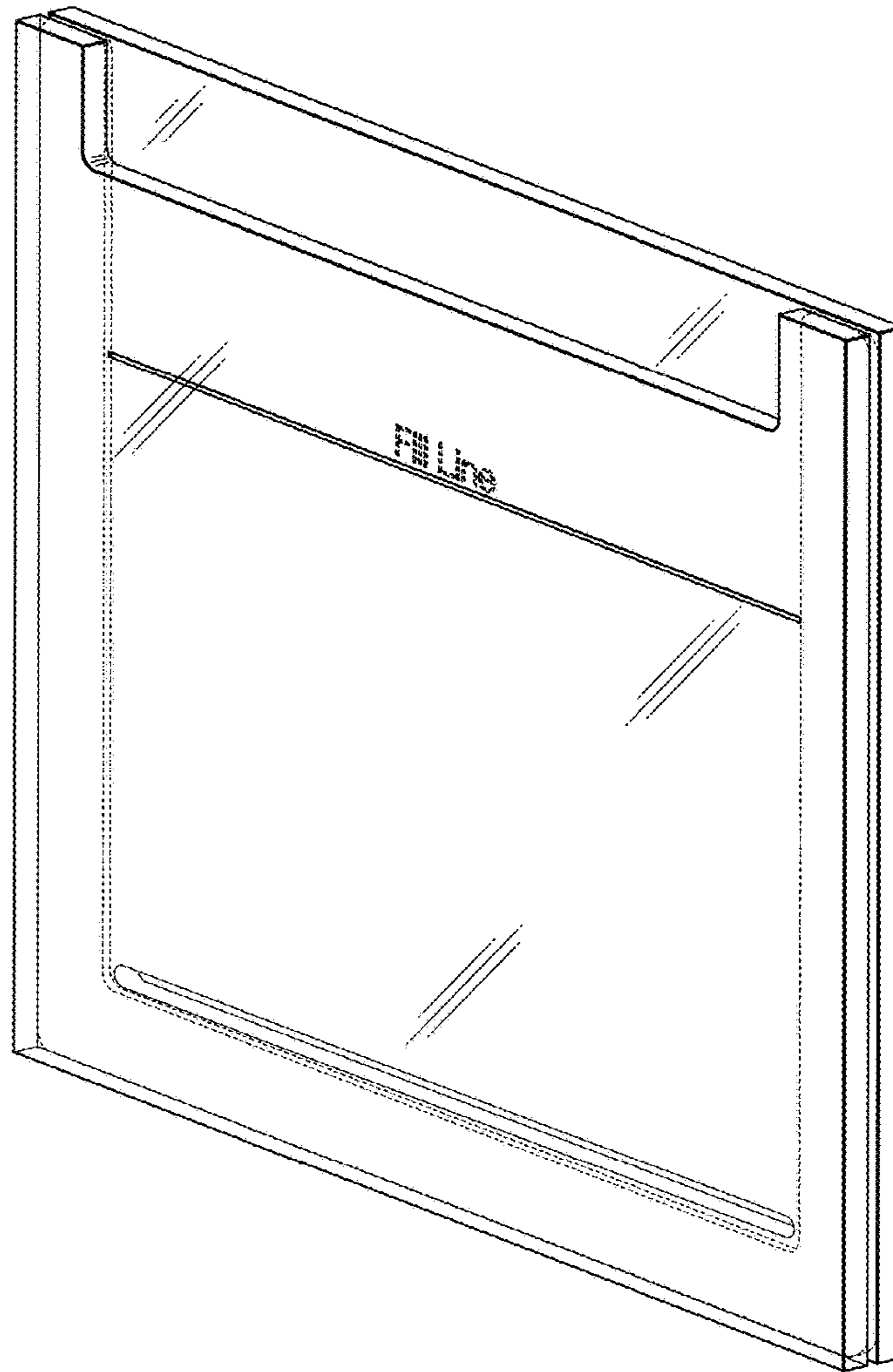

FIG. 9

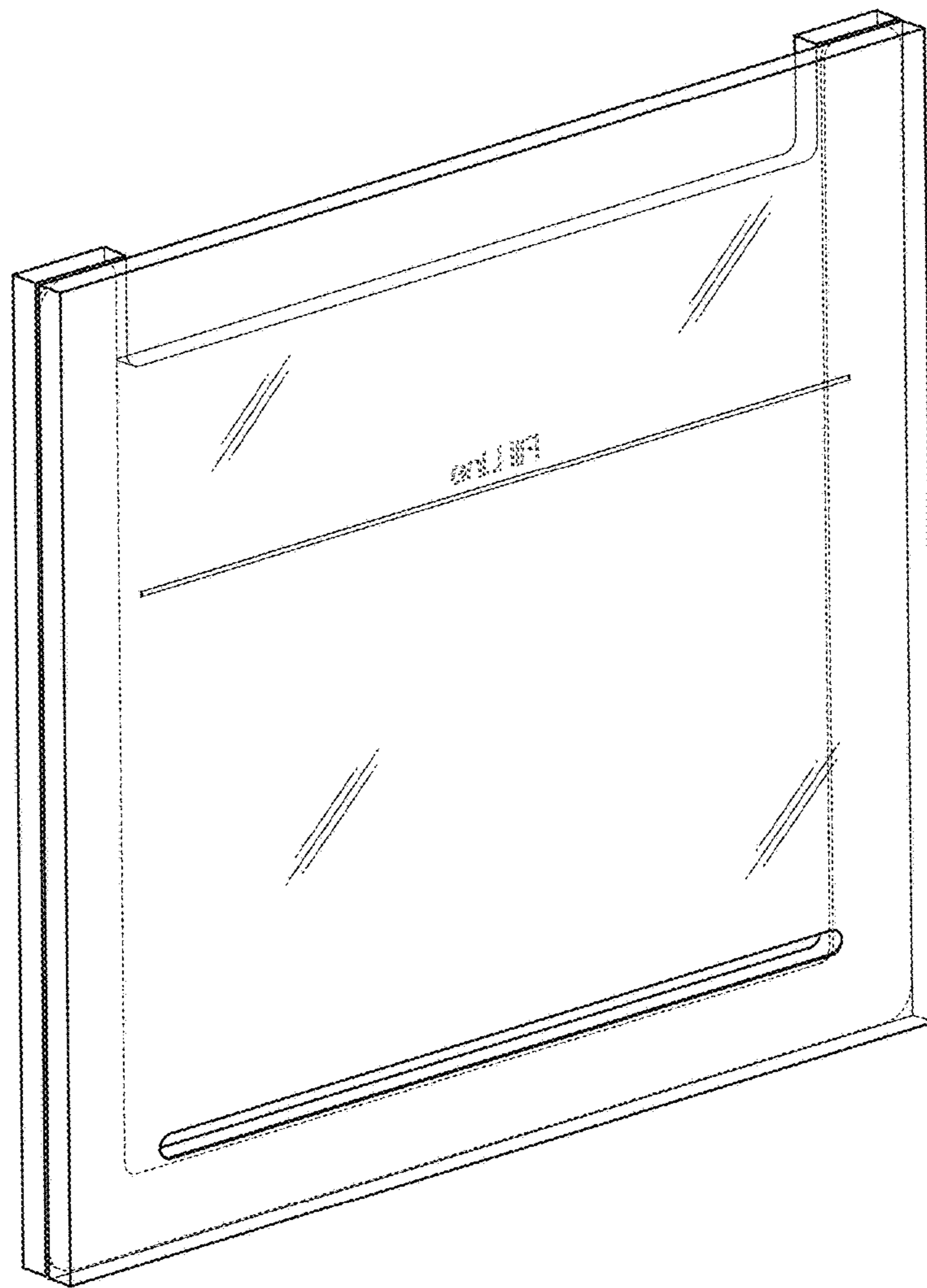

FIG. 10

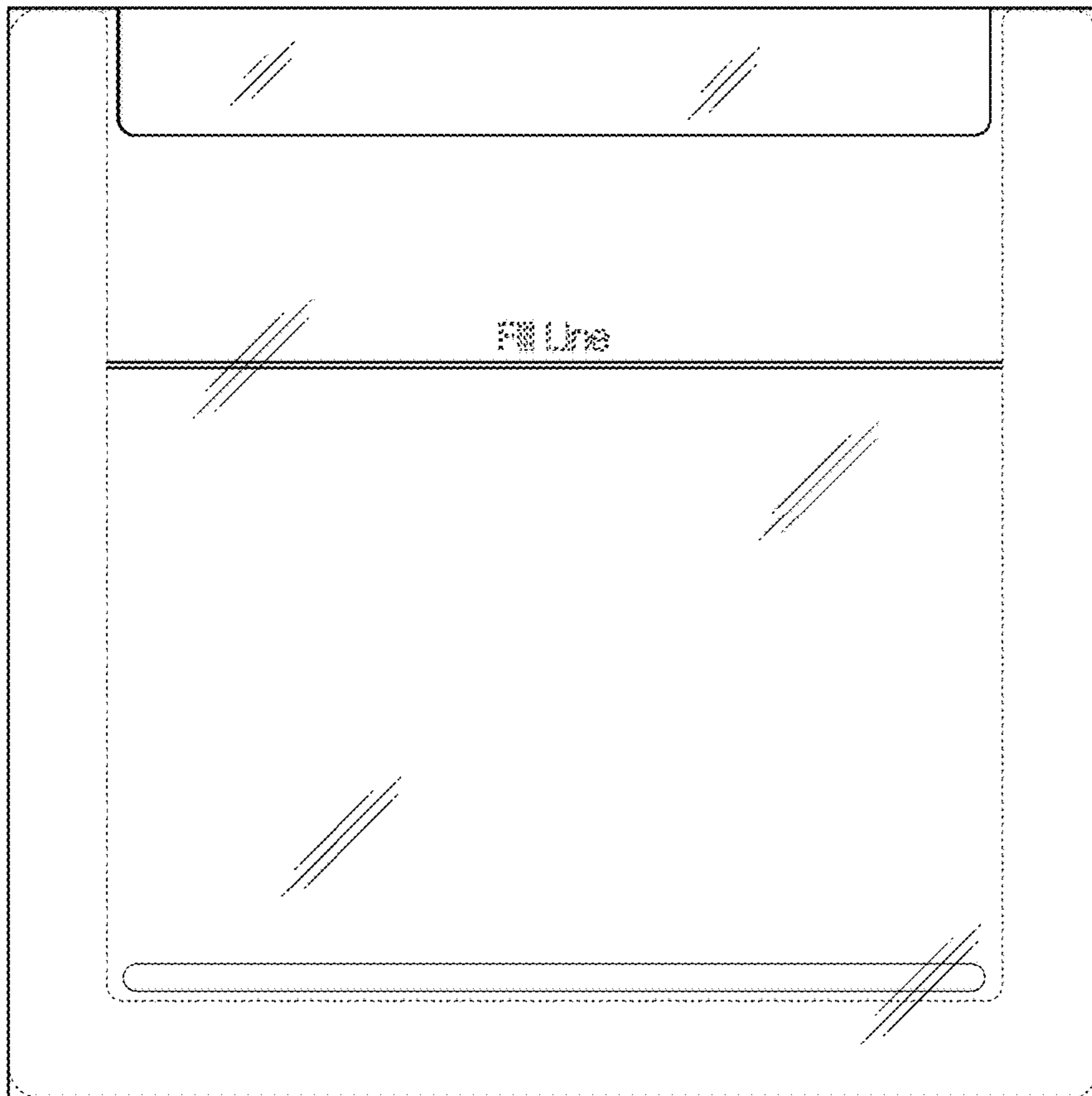

FIG. 11

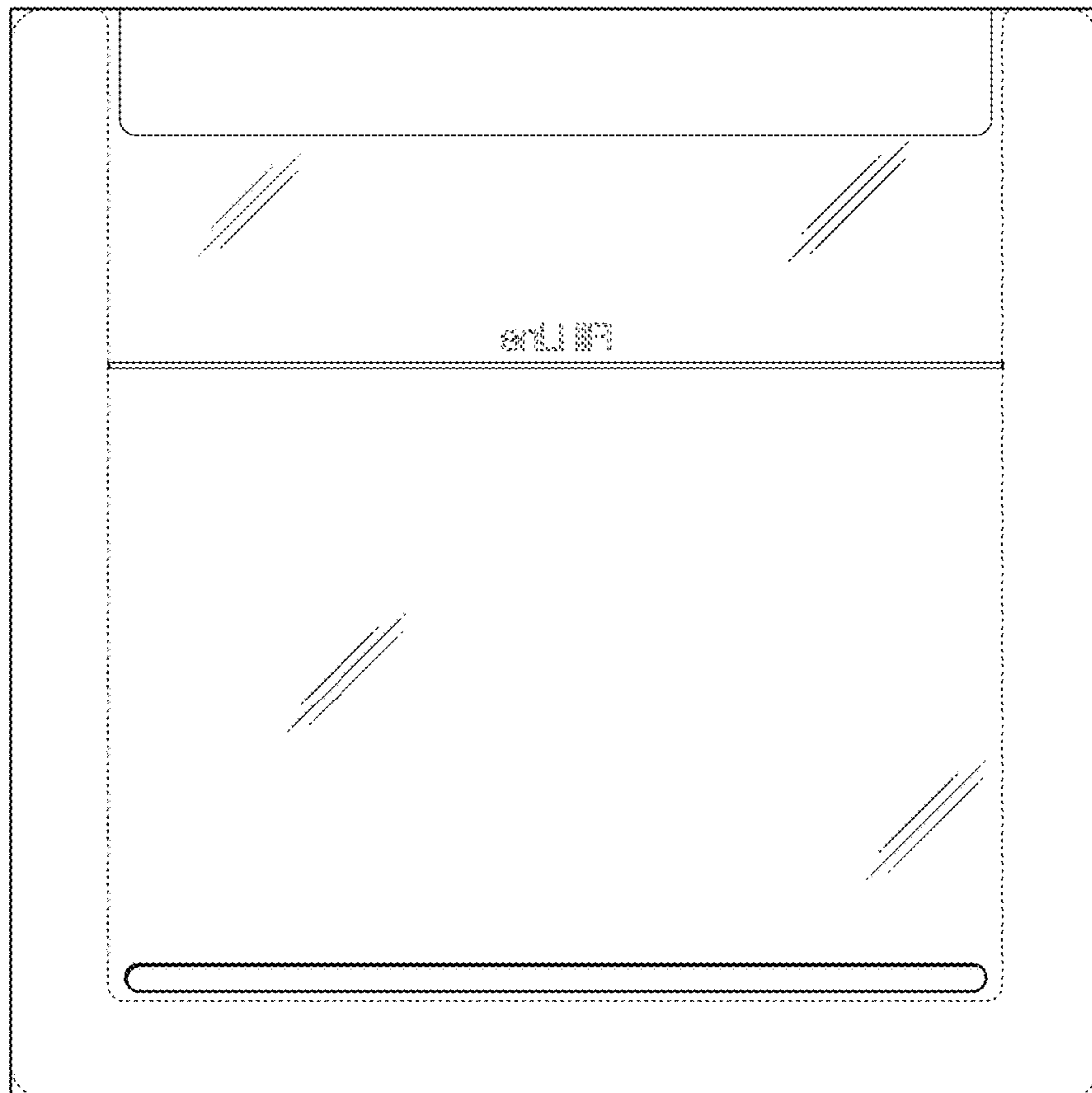

FIG. 12



FIG. 13

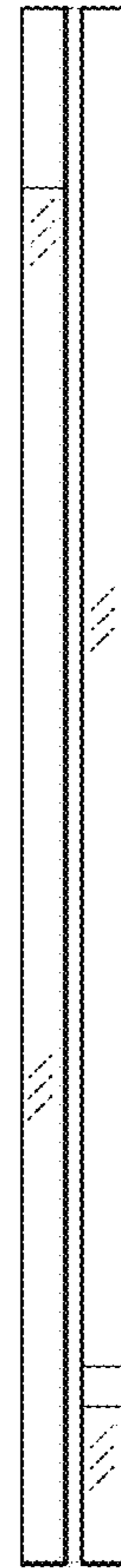

FIG. 14



FIG. 15



FIG. 16

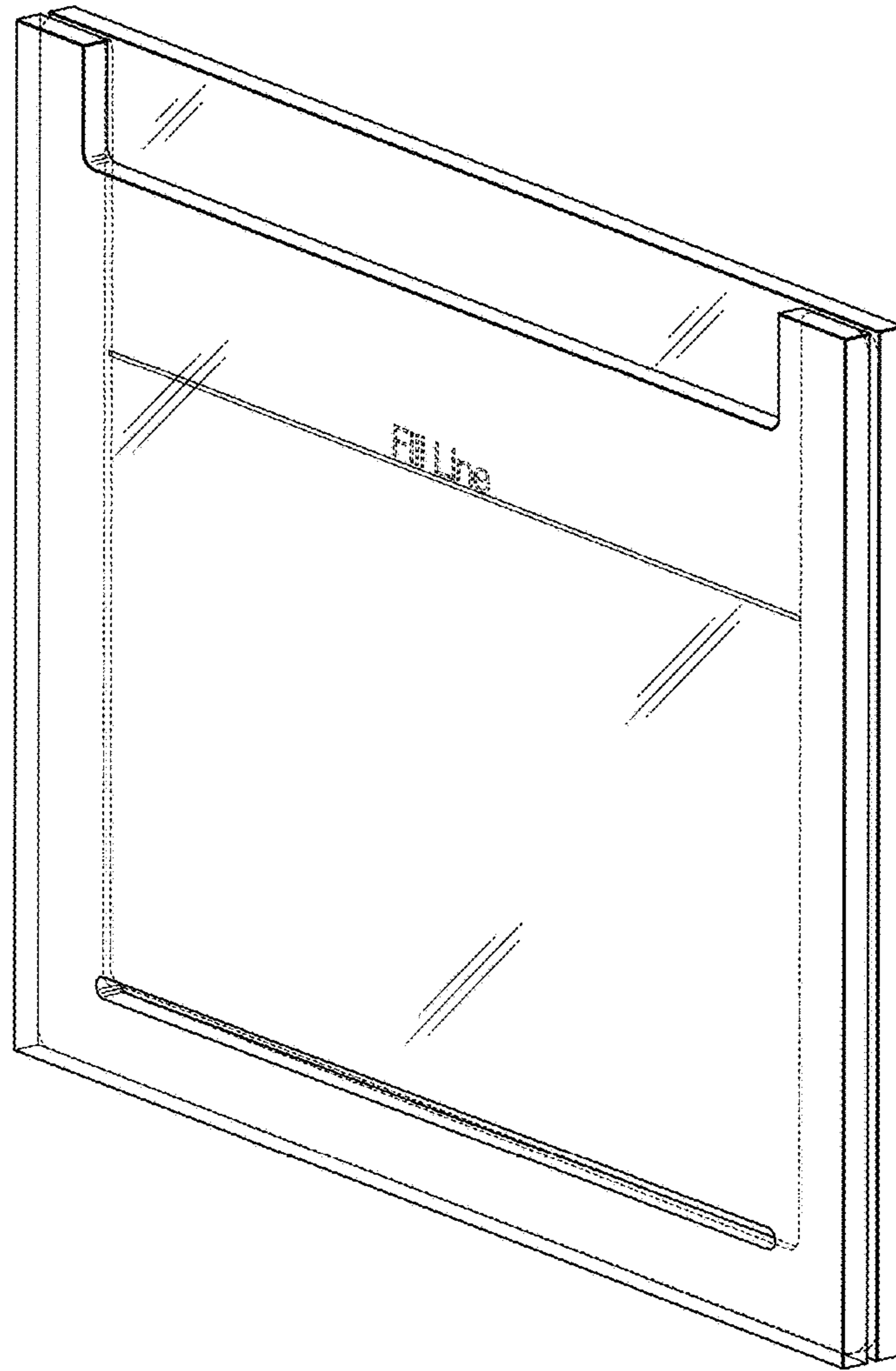

FIG. 17

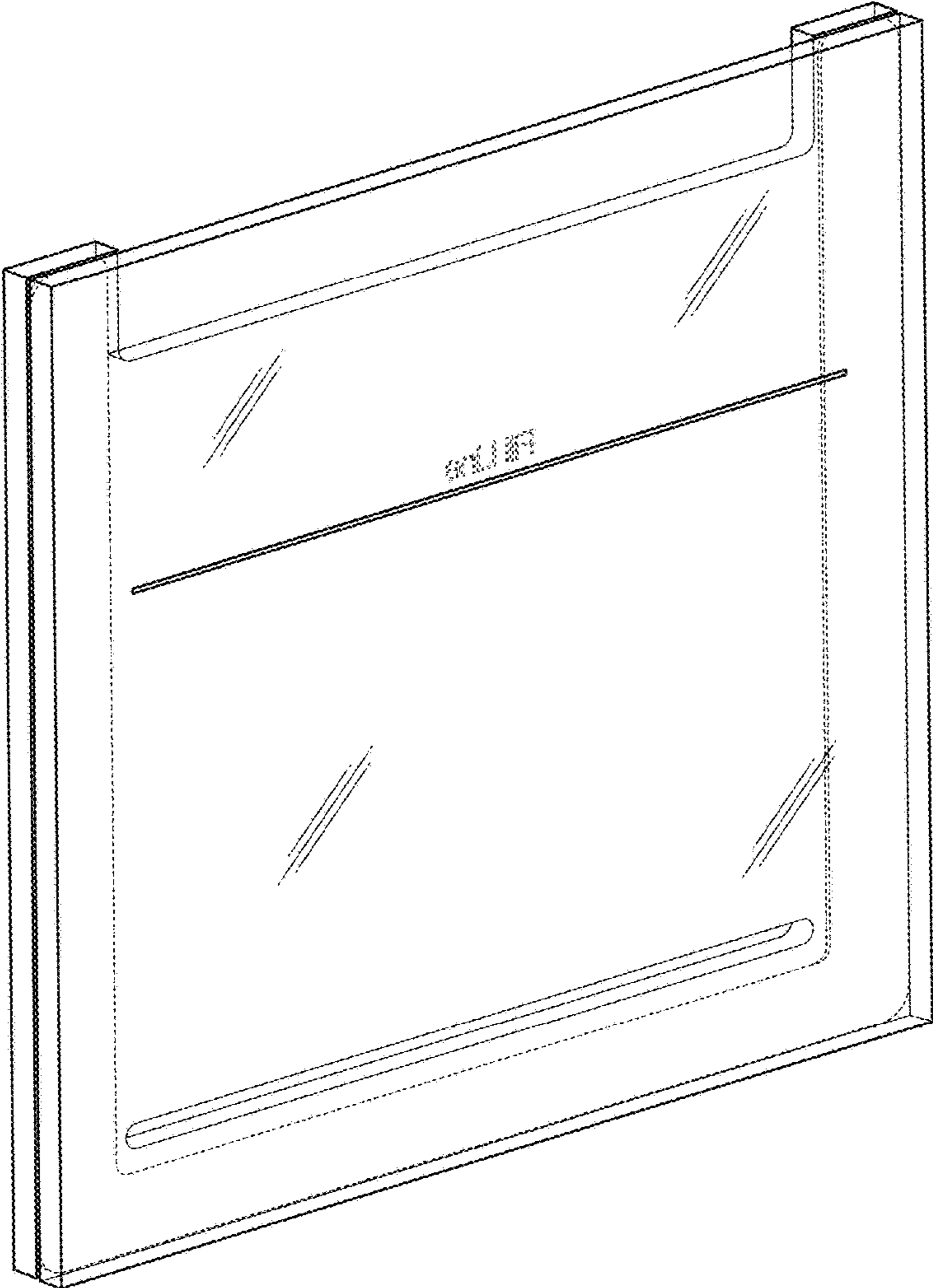

FIG. 18

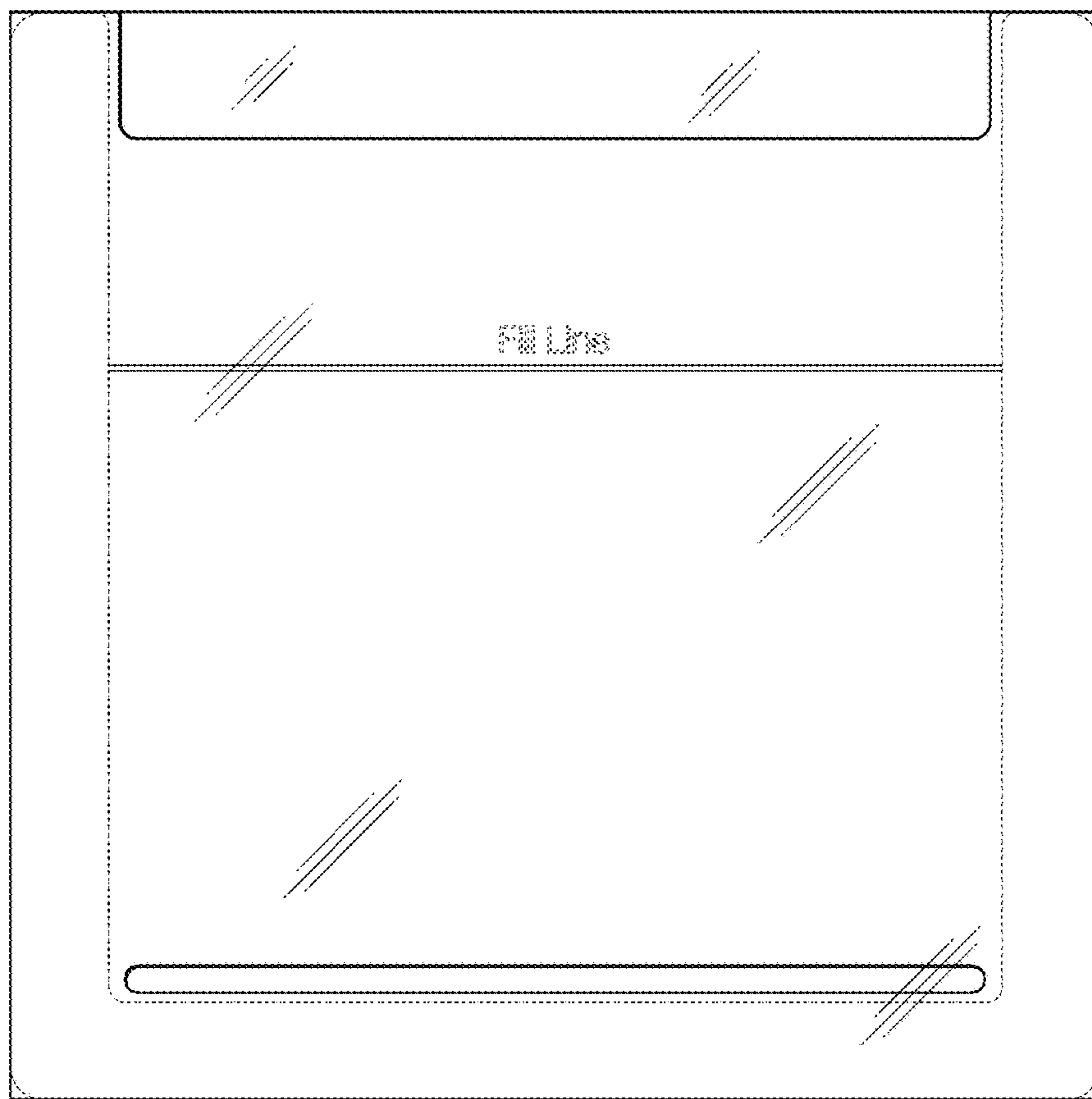

FIG. 19

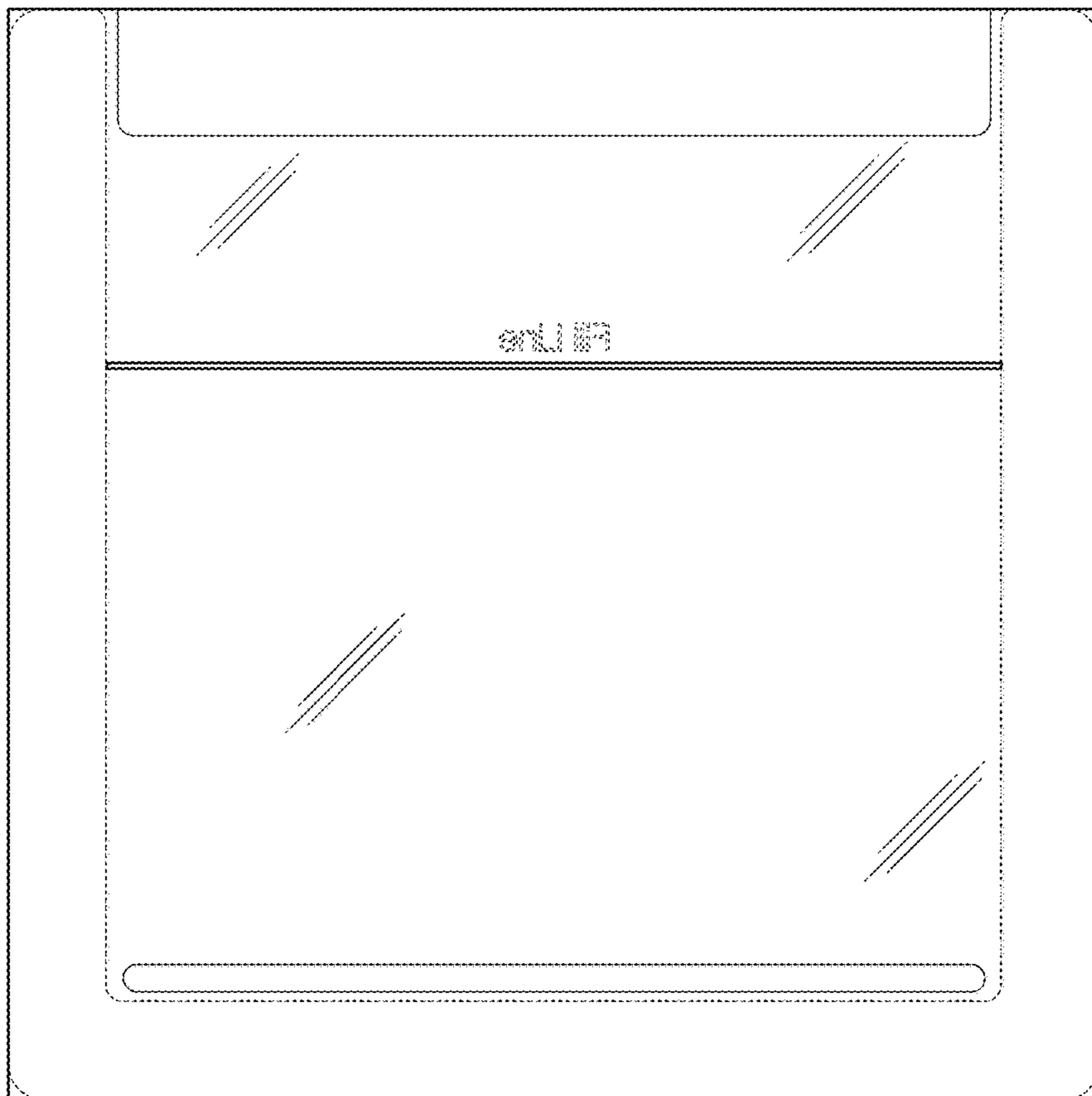

FIG. 20

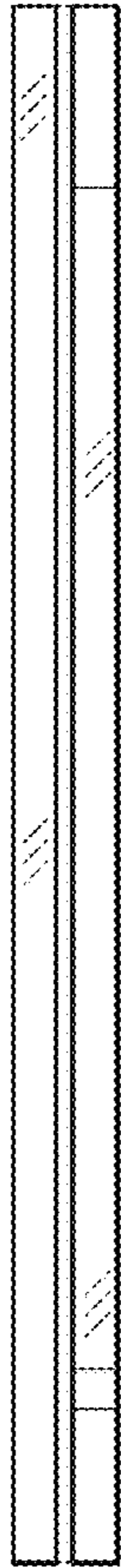

FIG. 21

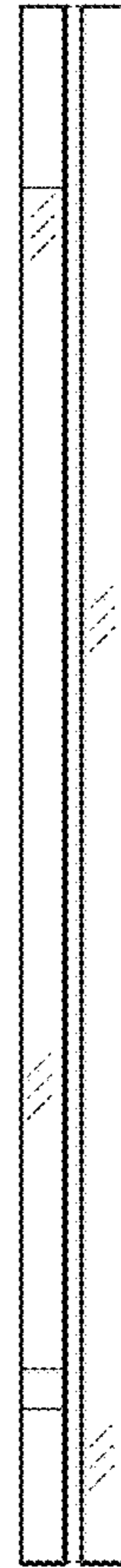

FIG. 22



FIG. 23

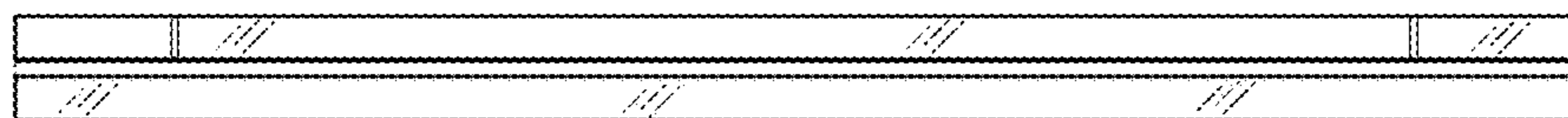

FIG. 24

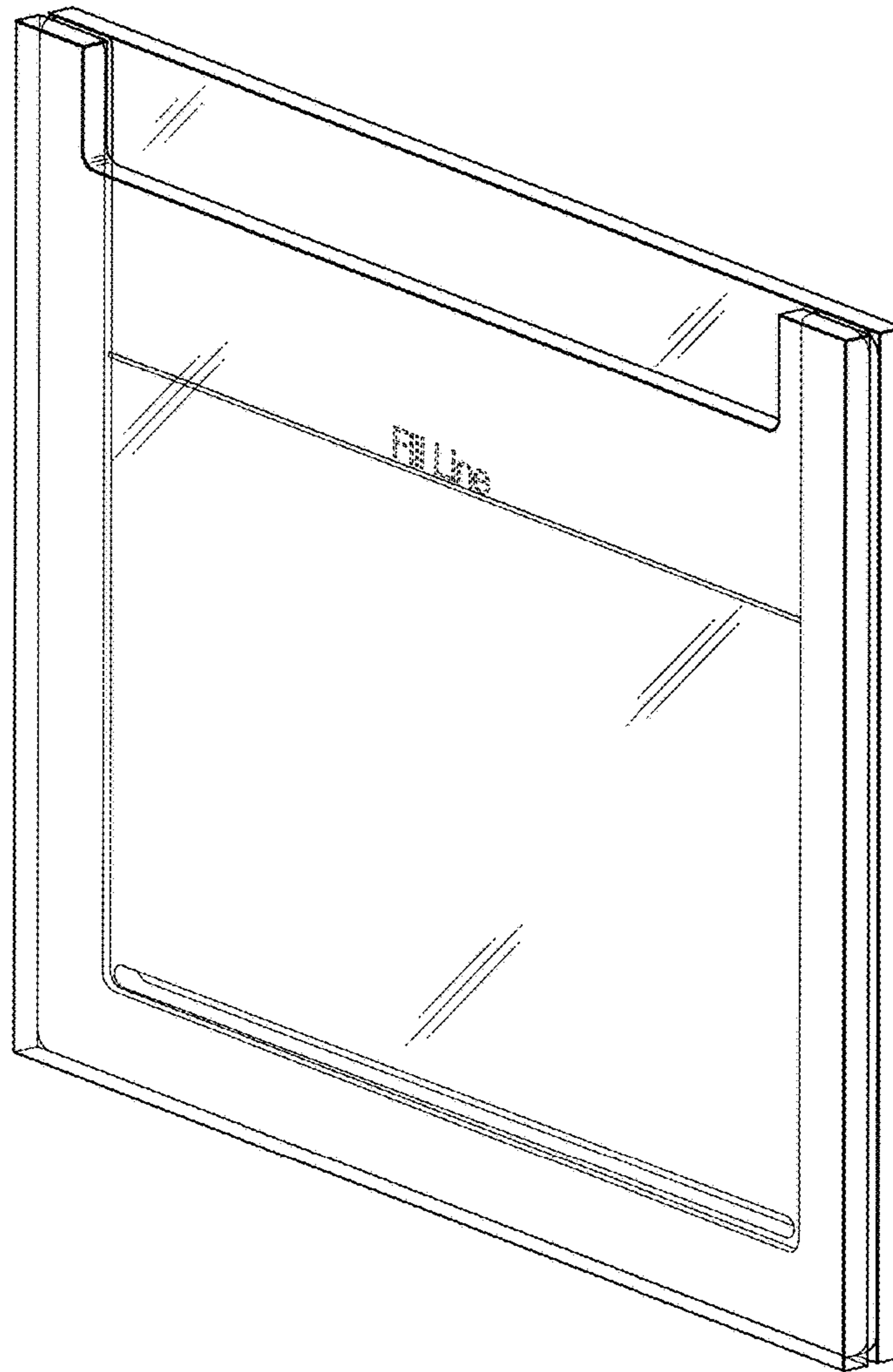

FIG. 25

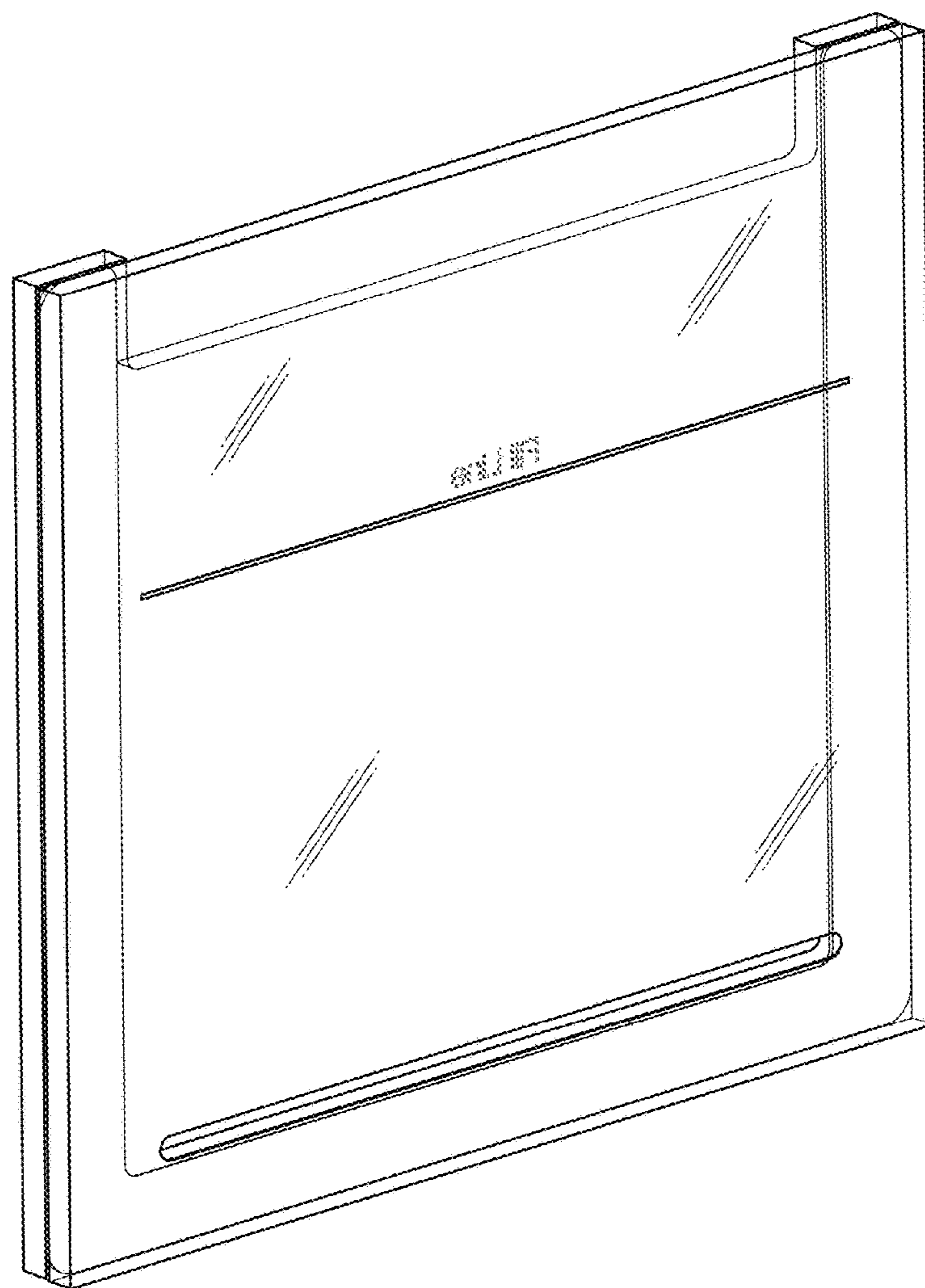

FIG. 26

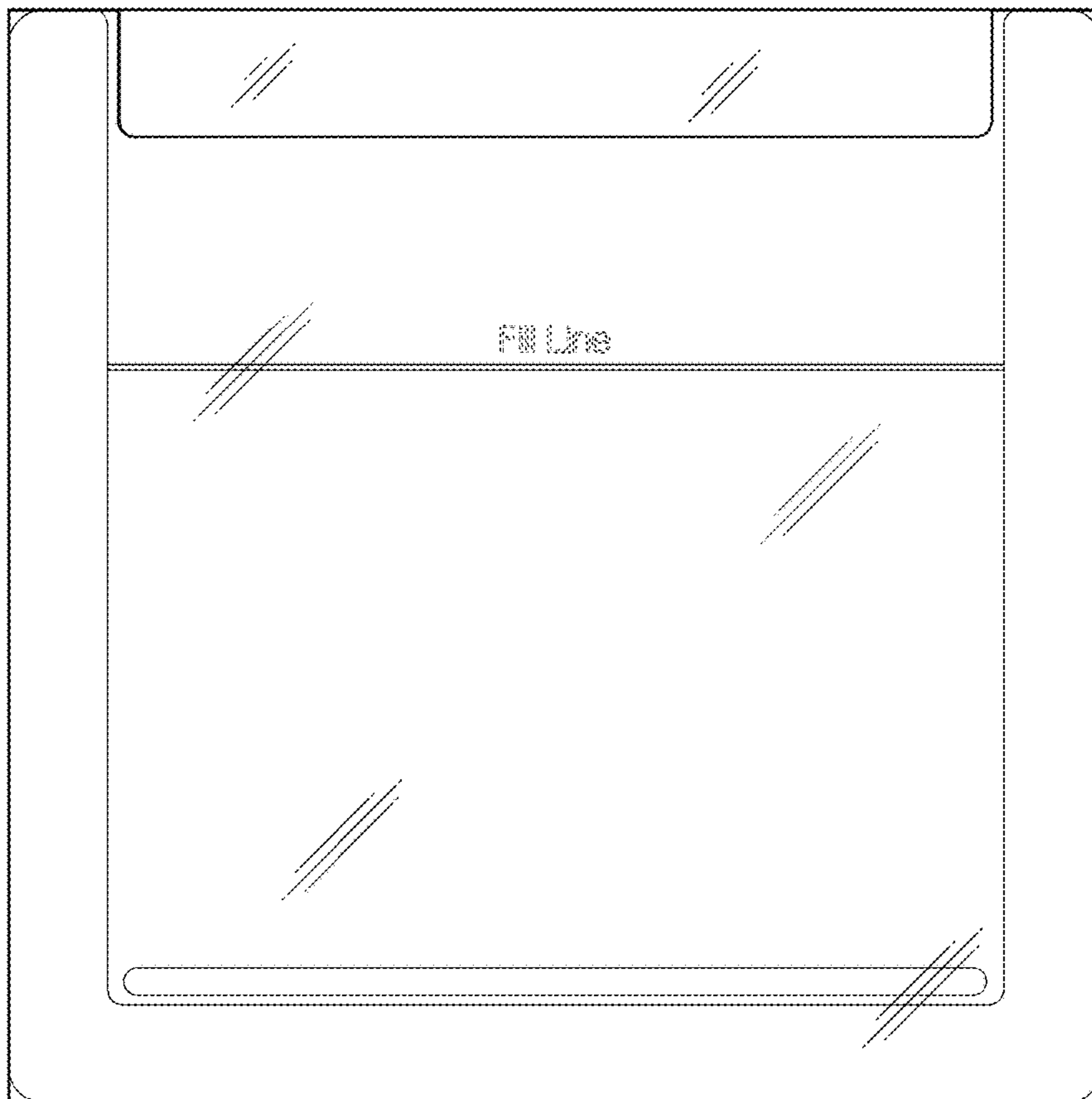
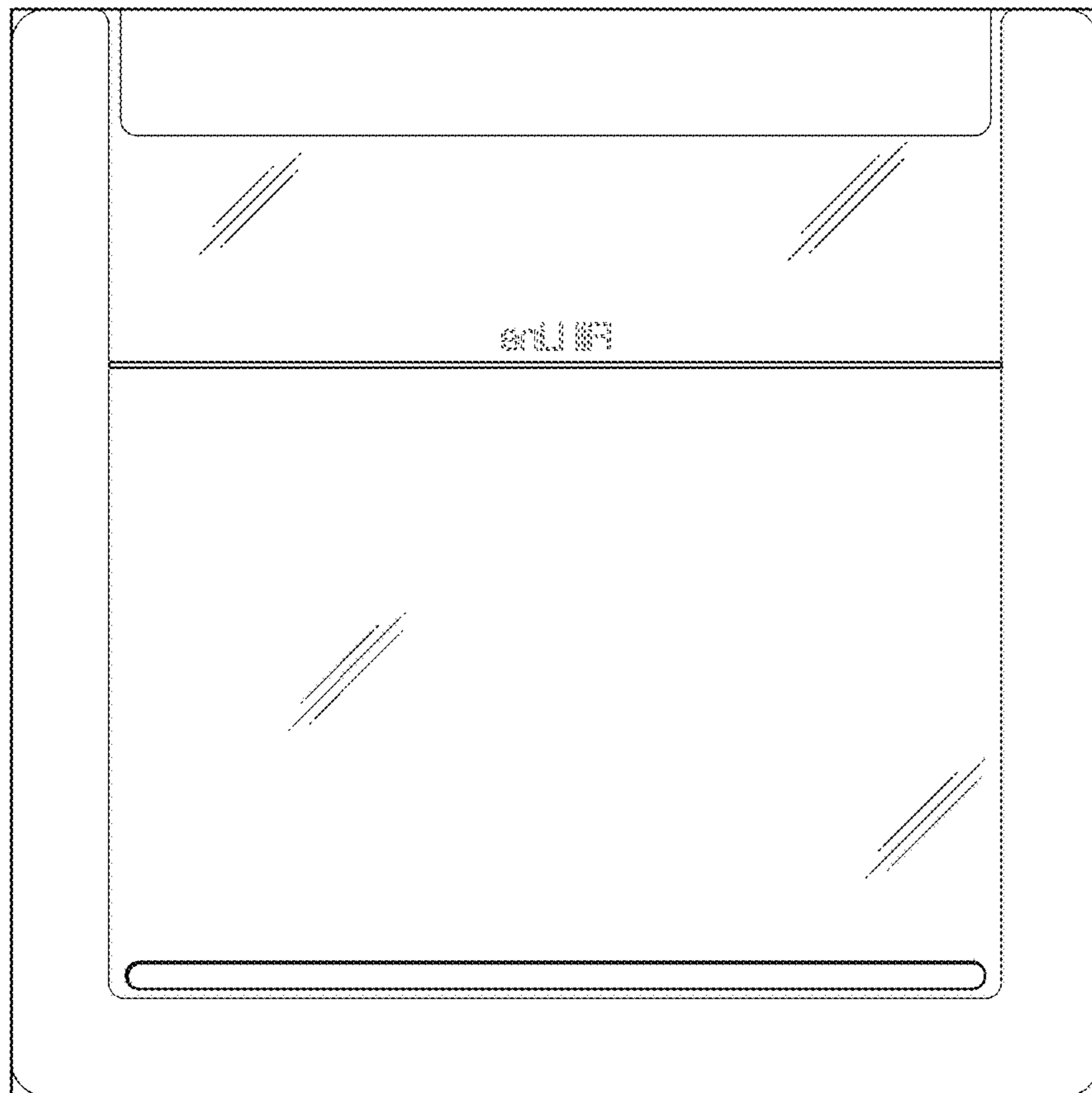

FIG. 27



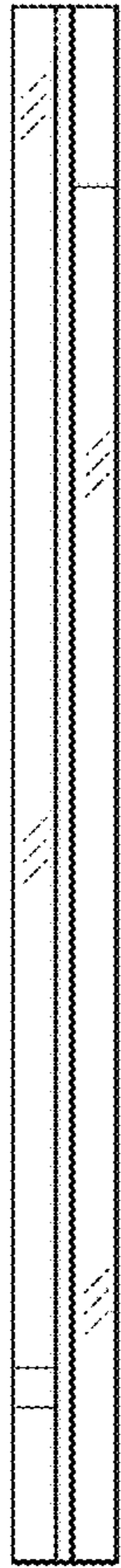

FIG. 29



FIG. 30

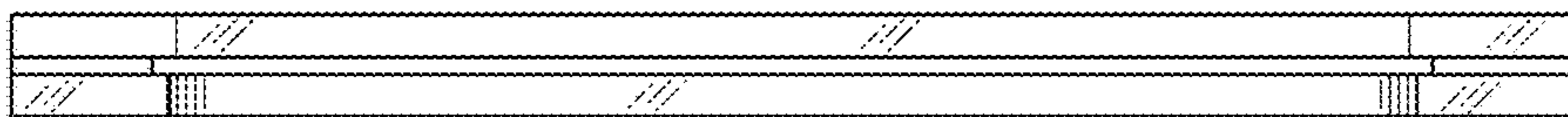

FIG. 31



FIG. 32