



US00D849798S

(12) **United States Design Patent**
Bendix

(10) **Patent No.:** **US D849,798 S**

(45) **Date of Patent:** **** May 28, 2019**

(54) **HANDLE FOR CARRYING SMALL ENGINES**

(71) Applicant: **Roger J. Bendix**, Fair Oaks, CA (US)

(72) Inventor: **Roger J. Bendix**, Fair Oaks, CA (US)

(**) Term: **15 Years**

(21) Appl. No.: **29/627,534**

(22) Filed: **Nov. 28, 2017**

(51) **LOC (11) Cl.** **15-01**

(52) **U.S. Cl.**
USPC **D15/5**

(58) **Field of Classification Search**
USPC D8/349, 352, 354, 356, 357, 360.1, 366,
D8/380, 382, 383, 394, 396, 499;
D12/87, 223; D15/1-7; D23/322, 323
CPC F02B 63/06; F02B 67/06; F02B 2275/06;
F02F 7/0046; Y10T 74/20828; B65D
25/32; B65H 75/4442; H02G 11/003;
H02G 11/02

See application file for complete search history.

(56) **References Cited**

U.S. PATENT DOCUMENTS

3,316,983	A	*	5/1967	Goodman	E21B 11/005
						173/147
D542,198	S	*	5/2007	Goodman	D12/180
D611,411	S	*	3/2010	Harmelink	D13/113
D625,334	S	*	10/2010	Gouge	D15/4
D709,742	S	*	7/2014	Luedtke	D8/107
D744,238	S	*	12/2015	Lai	D3/318

D747,879	S	*	1/2016	Fair	D3/318
D786,658	S	*	5/2017	Garcia	D8/358
D794,354	S	*	8/2017	Pan	D6/549

* cited by examiner

Primary Examiner — Garth Rademaker

Assistant Examiner — Fritzgerald L Butac

(57) **CLAIM**

The ornamental design for a handle for carrying small engines, as shown.

DESCRIPTION

FIG. 1 is a front perspective view of a handle for carrying small engines showing our new design in an environment of use.

FIG. 2 is a rear perspective view thereof;

FIG. 3 is a front perspective view thereof;

FIG. 4 is a rear perspective view thereof;

FIG. 5 is a top plan view thereof;

FIG. 6 is a bottom plan view thereof;

FIG. 7 is a left elevational view thereof;

FIG. 8 is a right elevational view thereof;

FIG. 9 is a front elevational view thereof; and,

FIG. 10 is a rear elevational view thereof.

The broken lines in FIG. 1 and FIG. 2 showing an engine are for the purpose of showing environmental structure, and form no part of the claimed design.

1 Claim, 5 Drawing Sheets

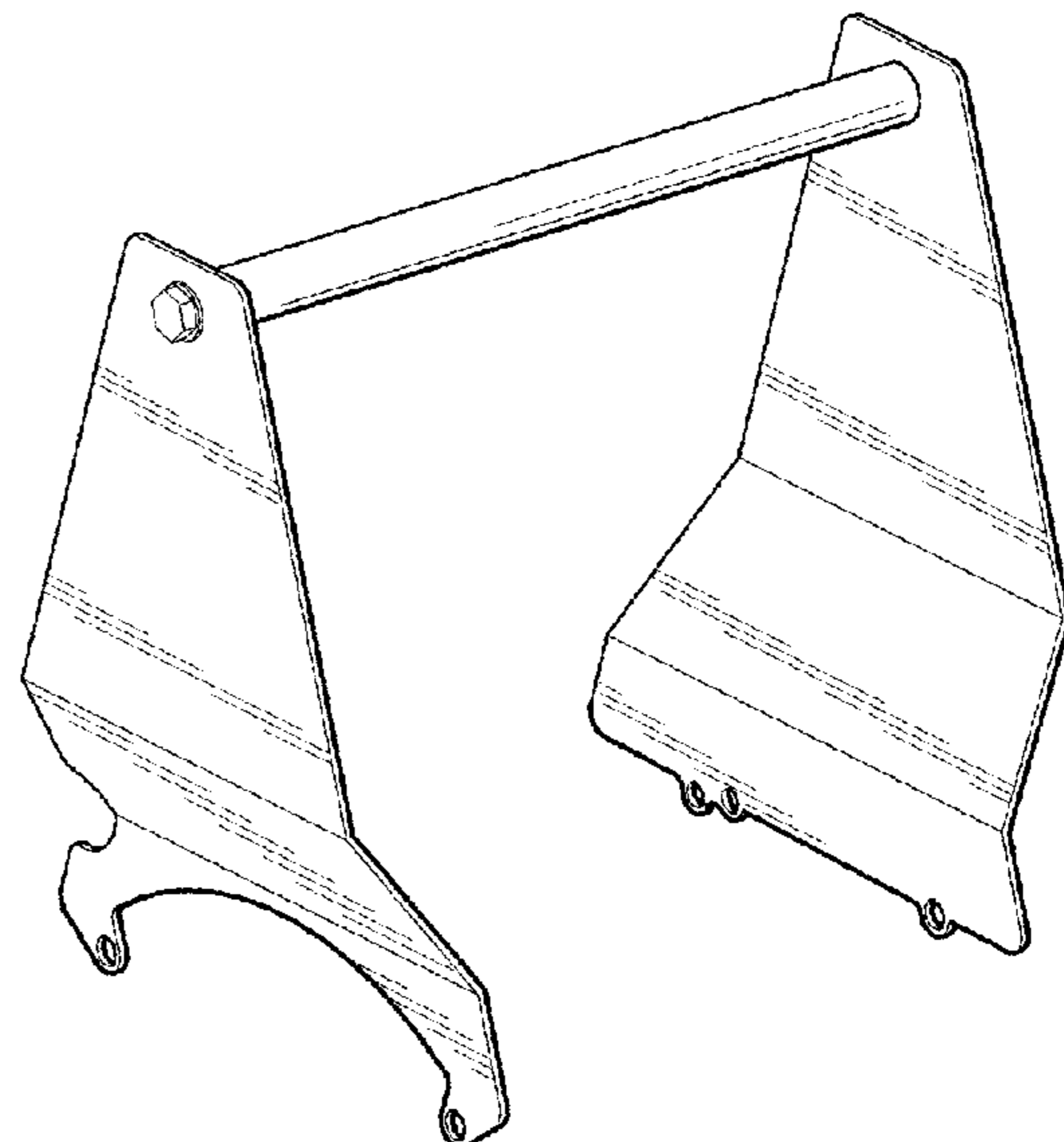
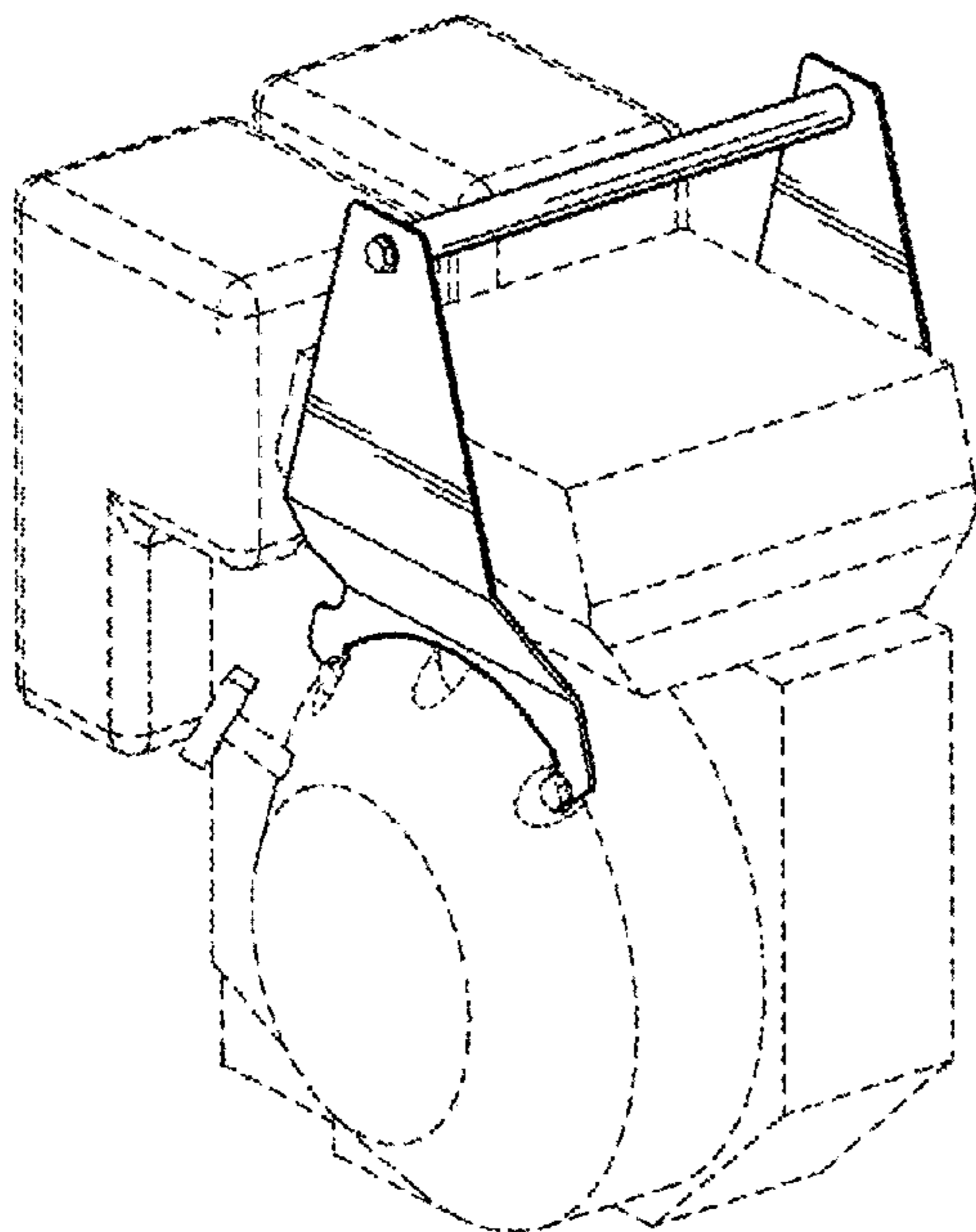

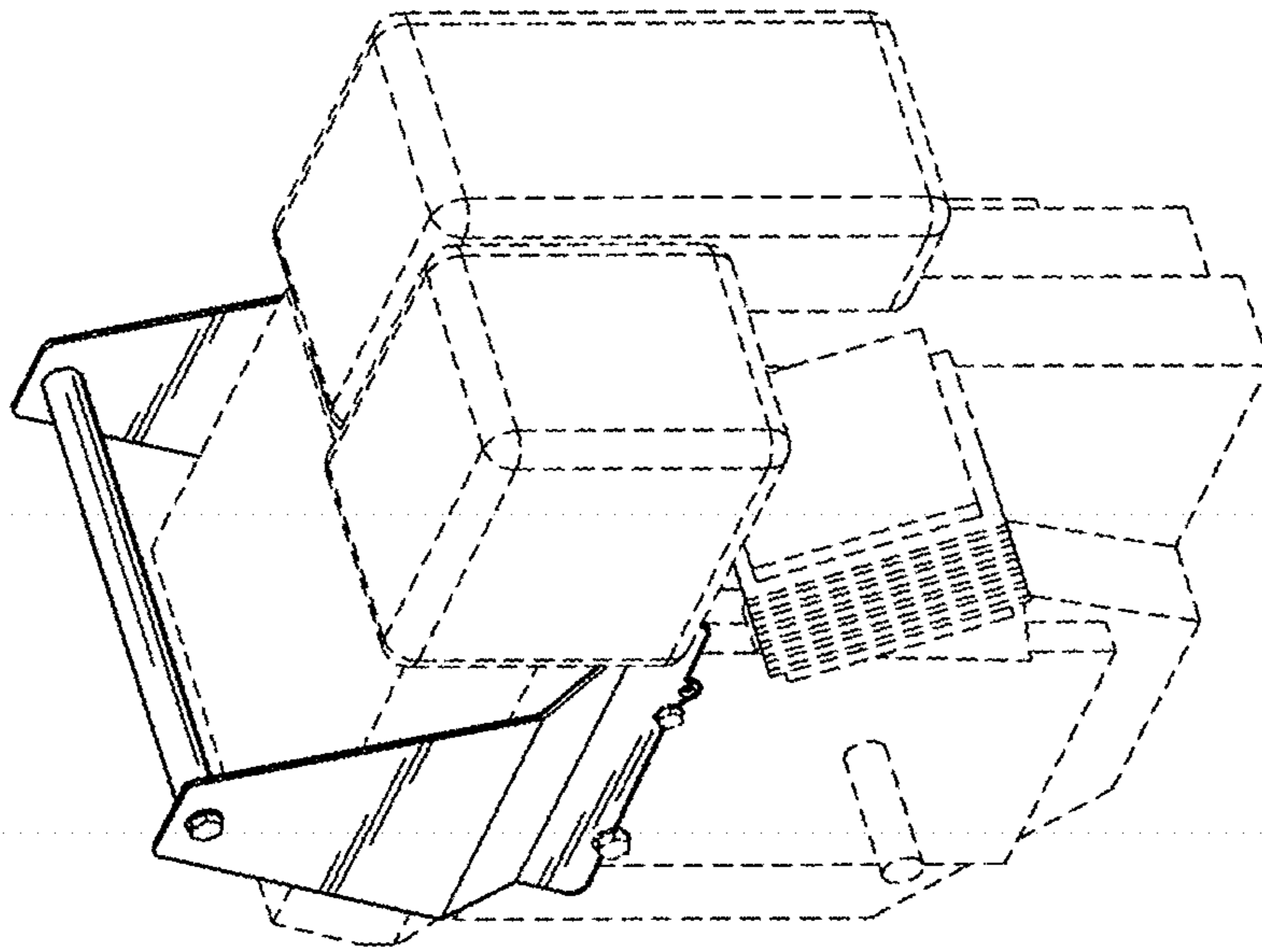

FIG. 2

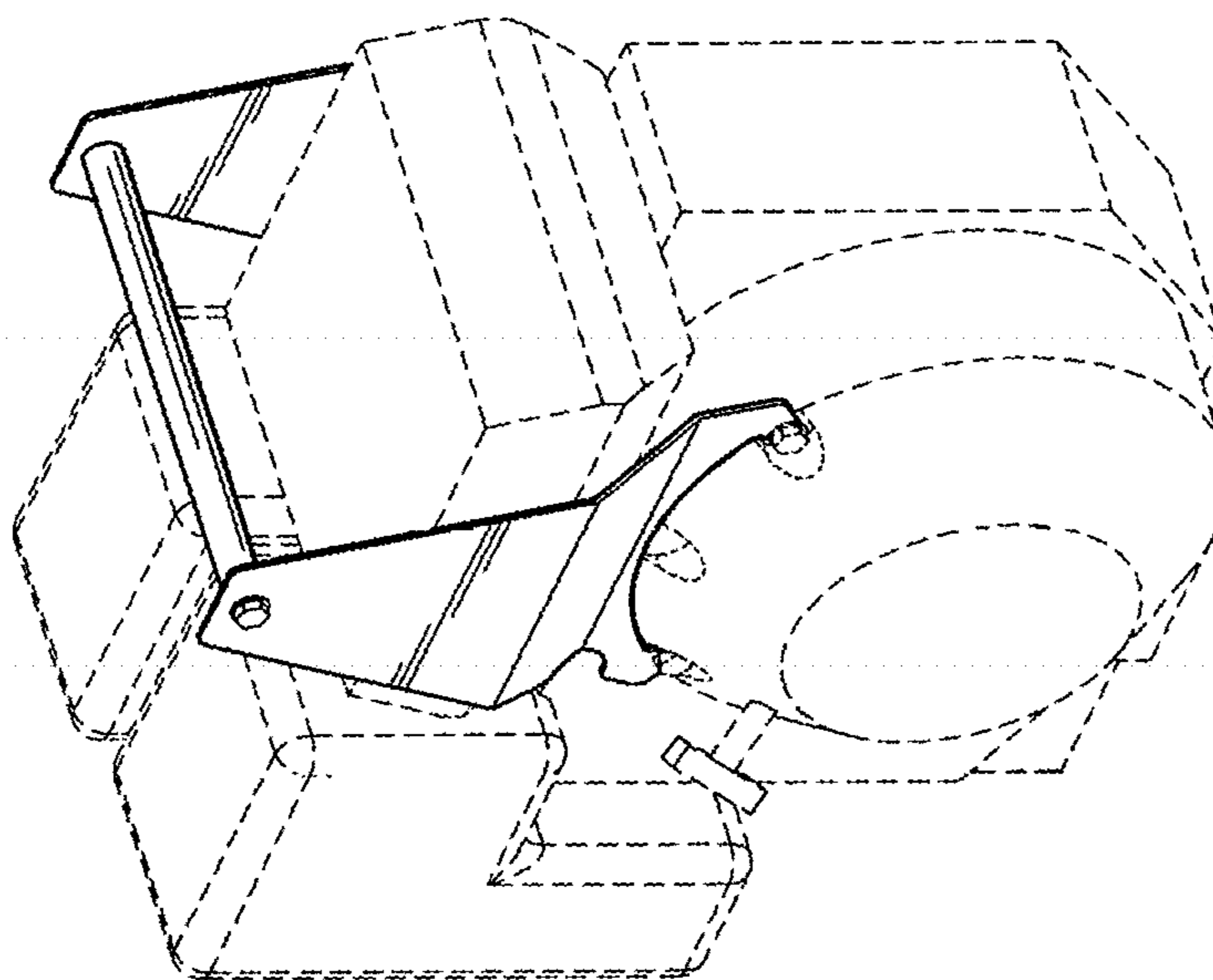

FIG. 1

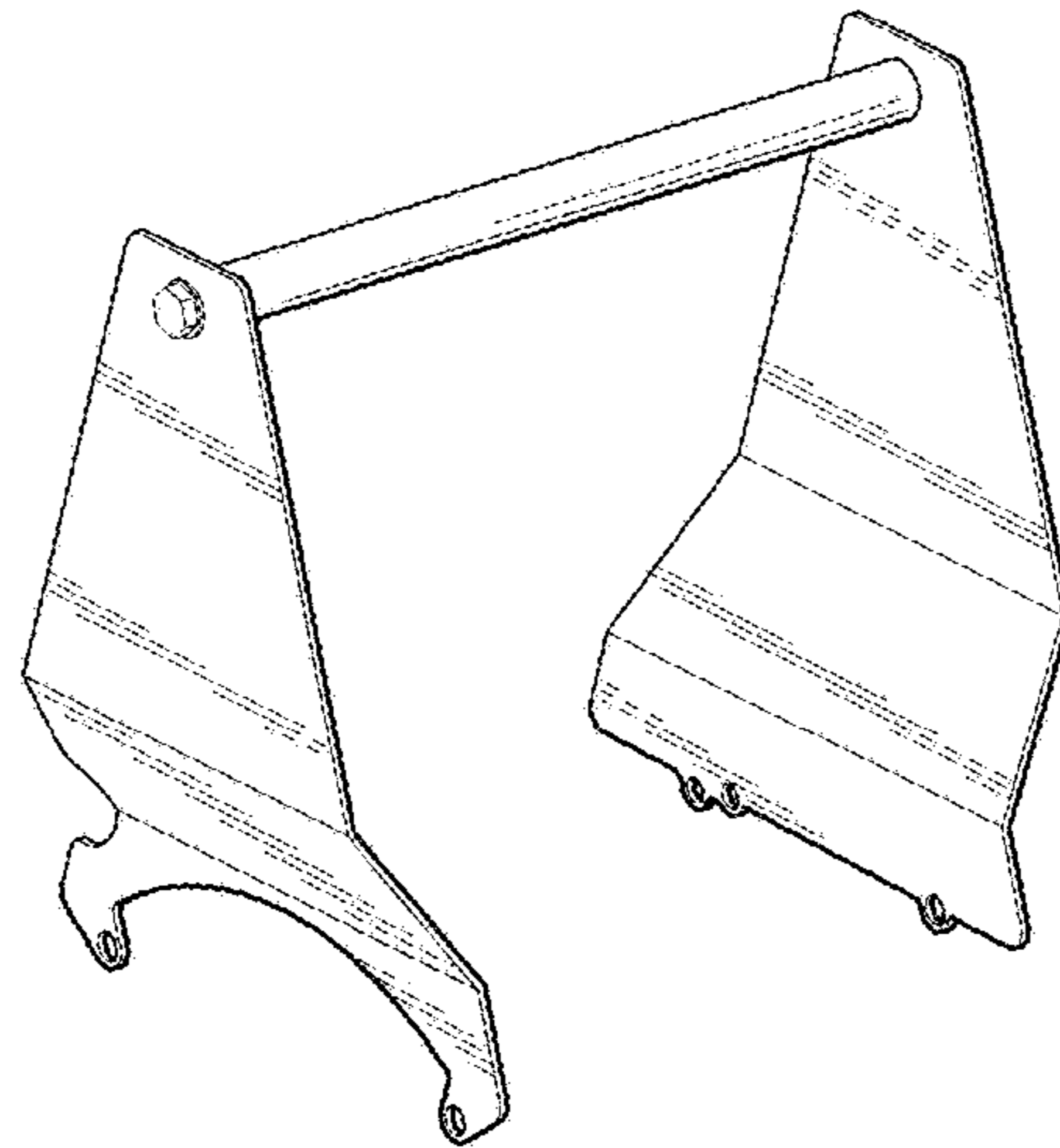

FIG. 3

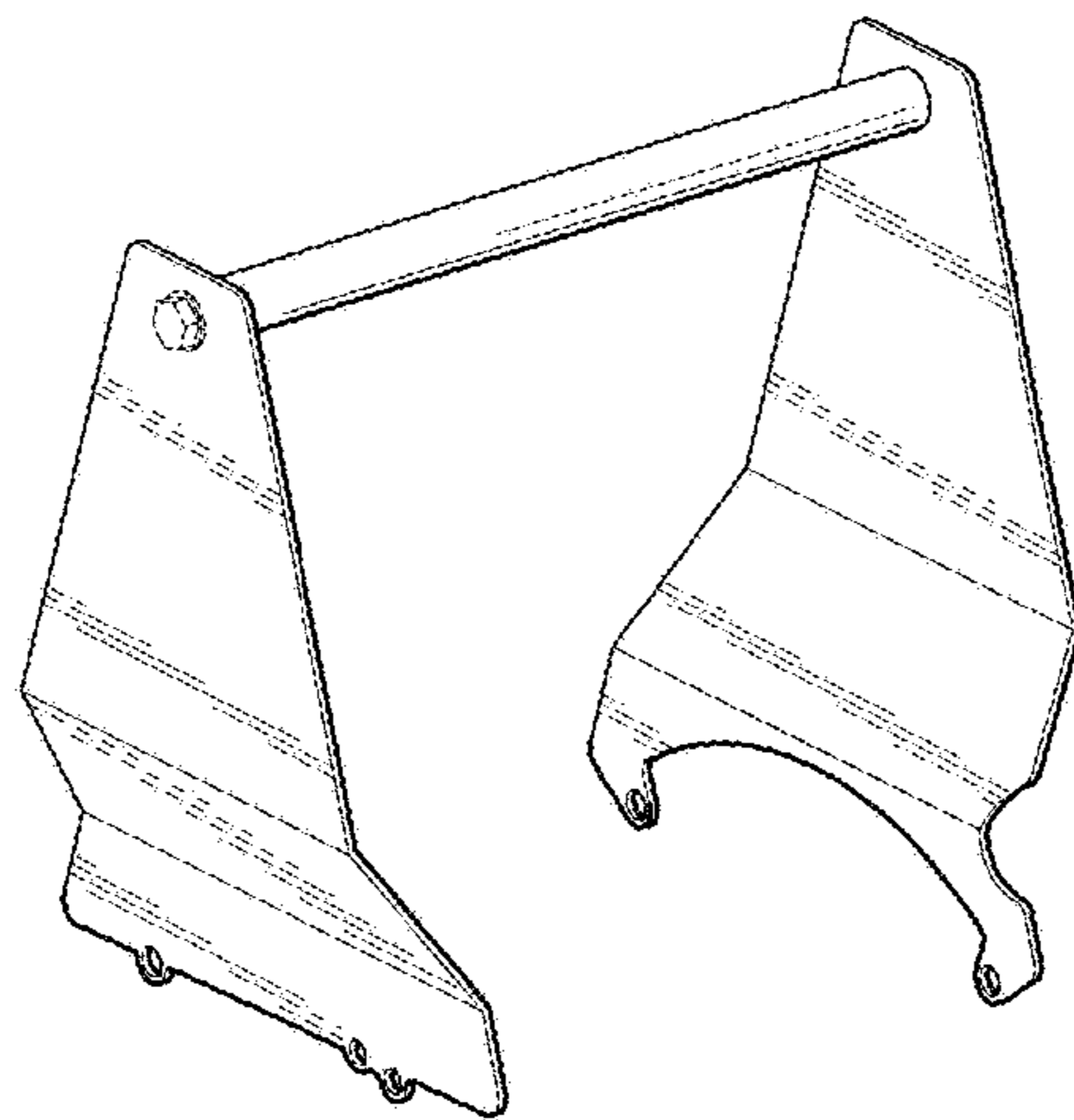

FIG. 4

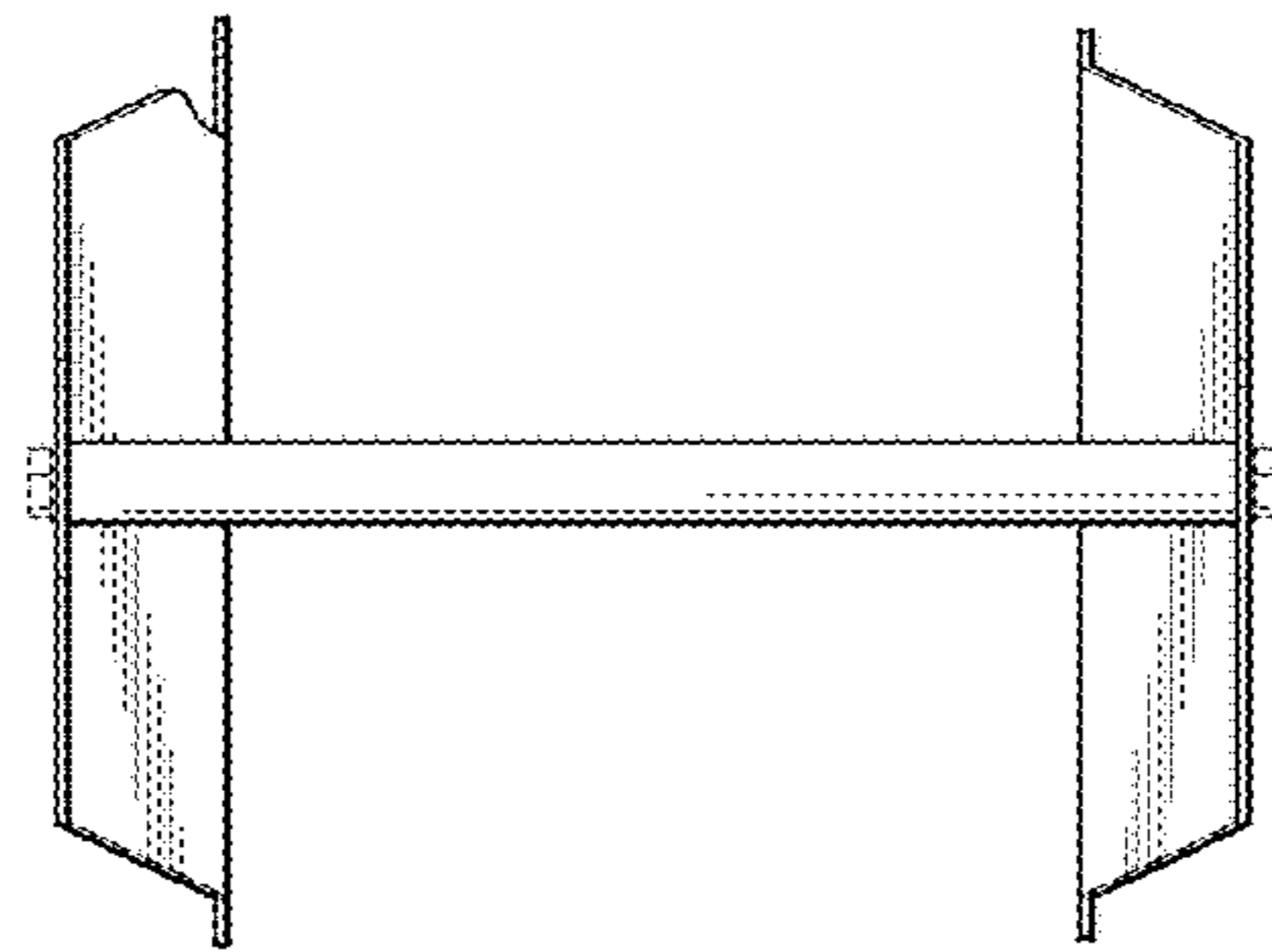

FIG. 5

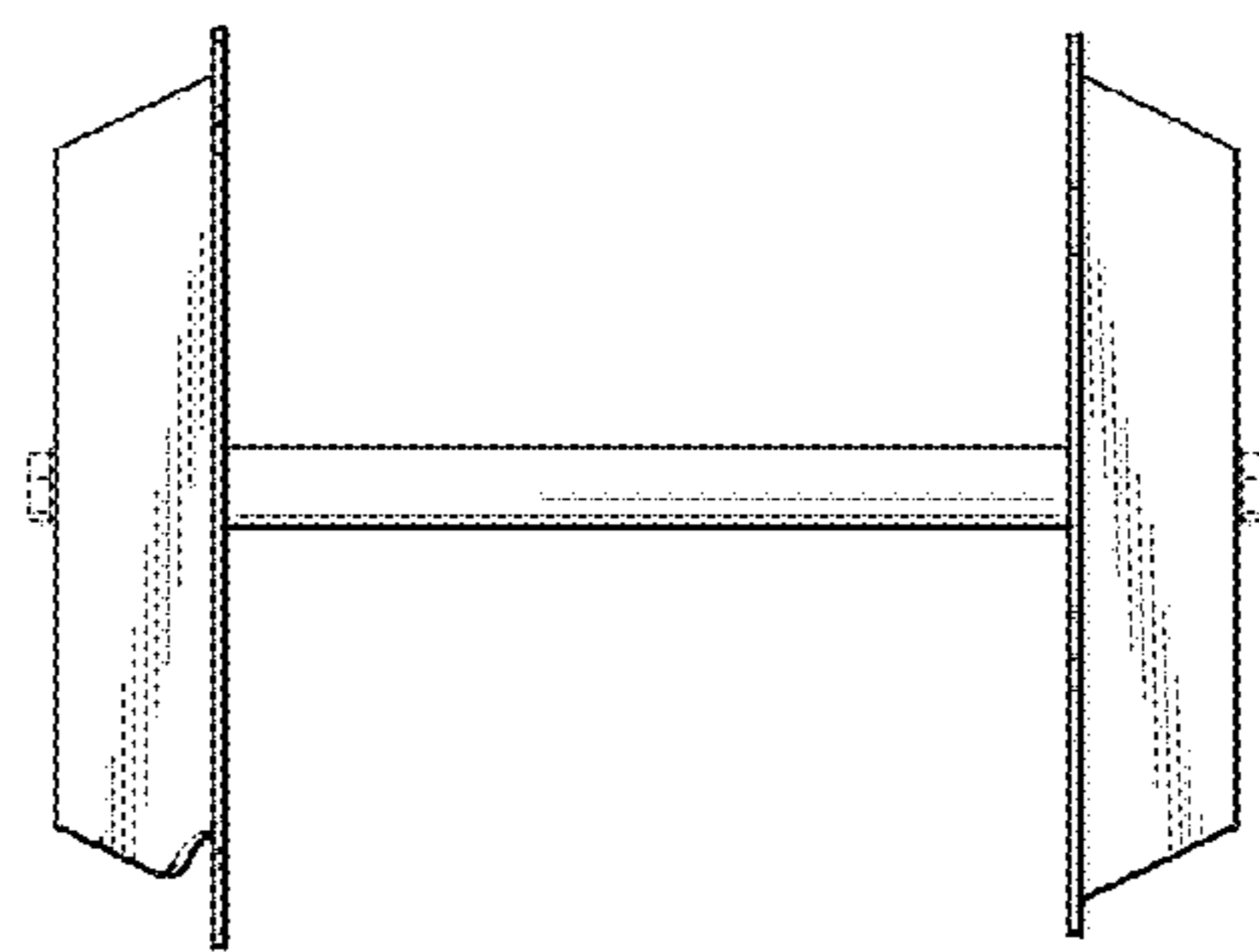

FIG. 6

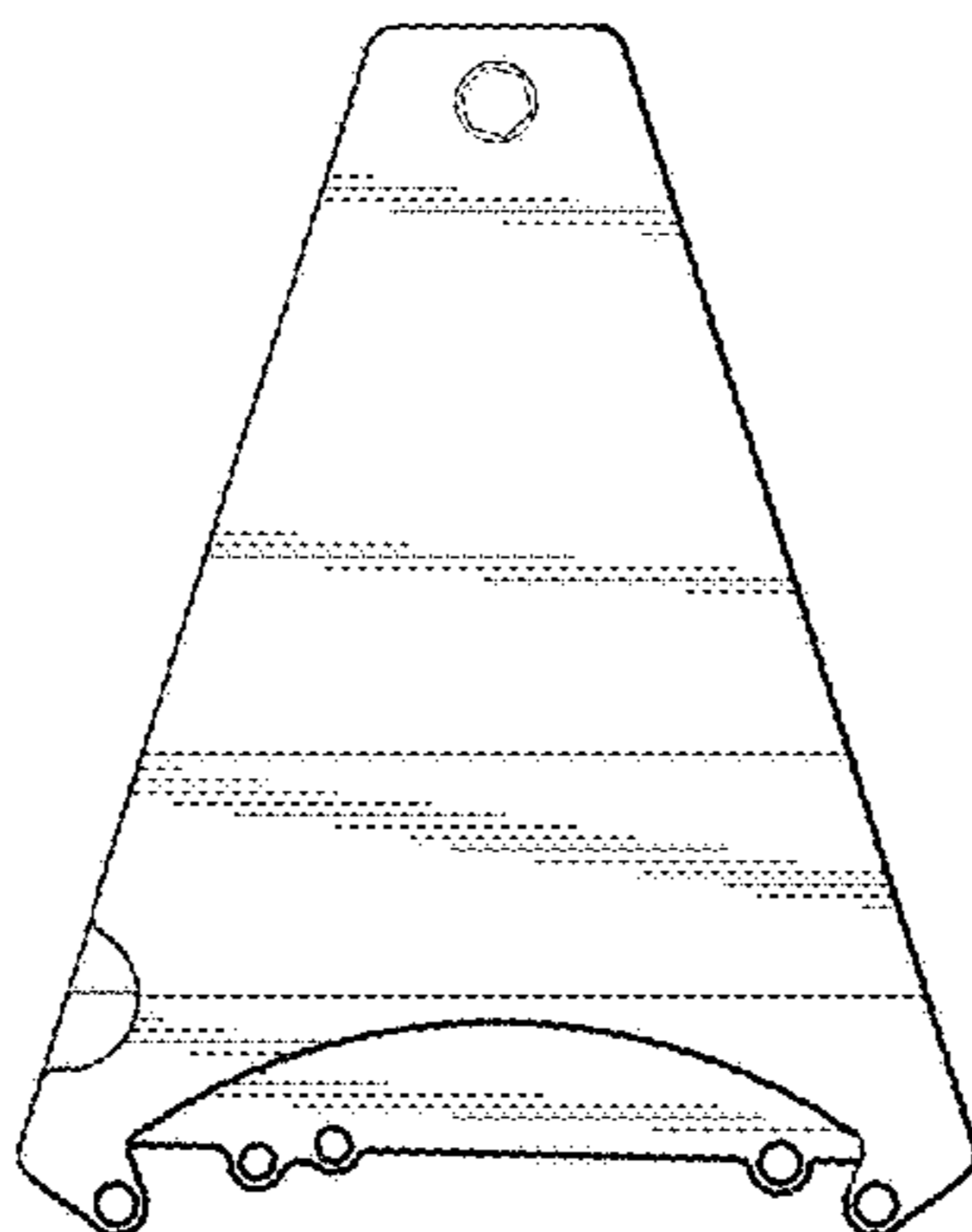

FIG. 7

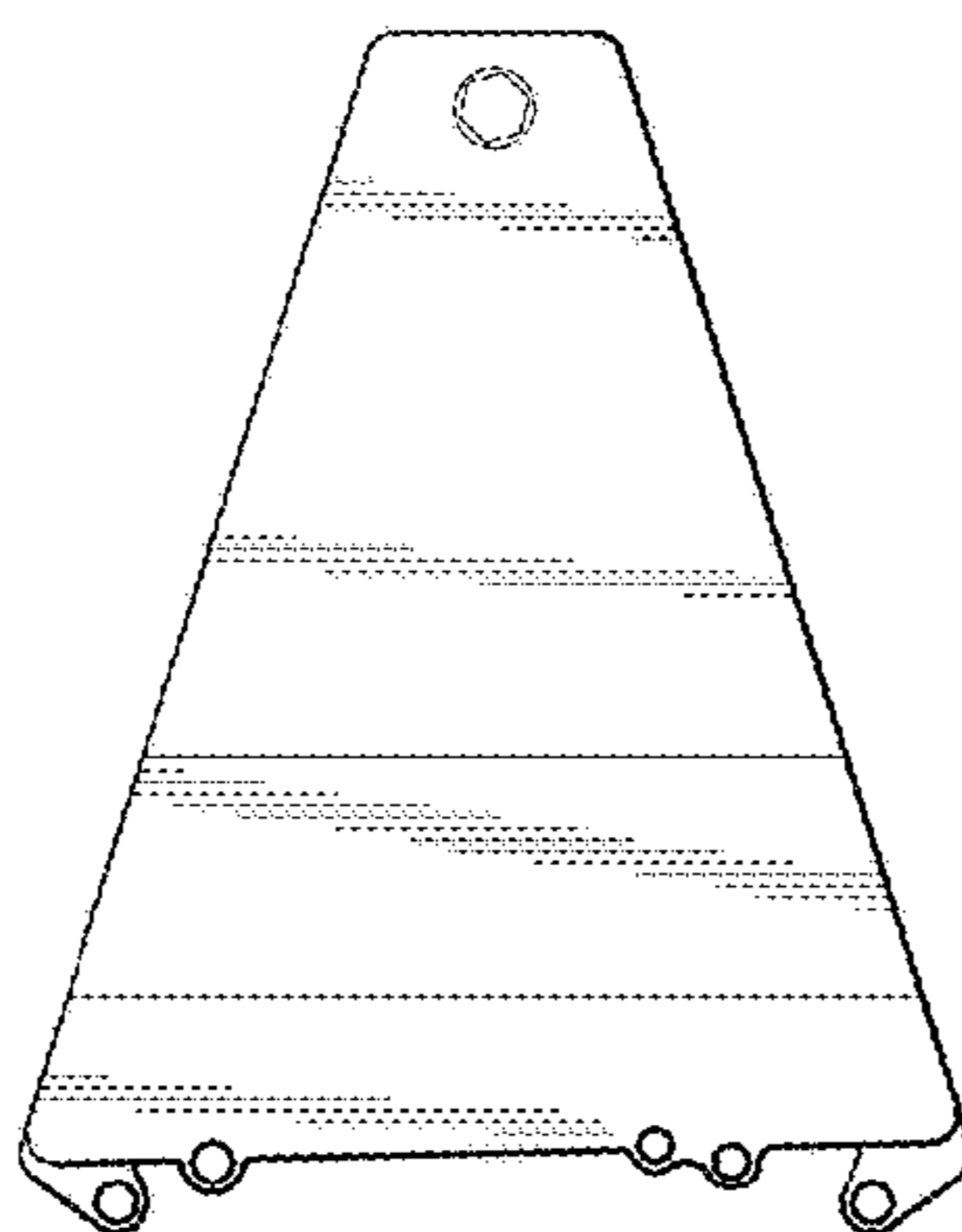

FIG. 8

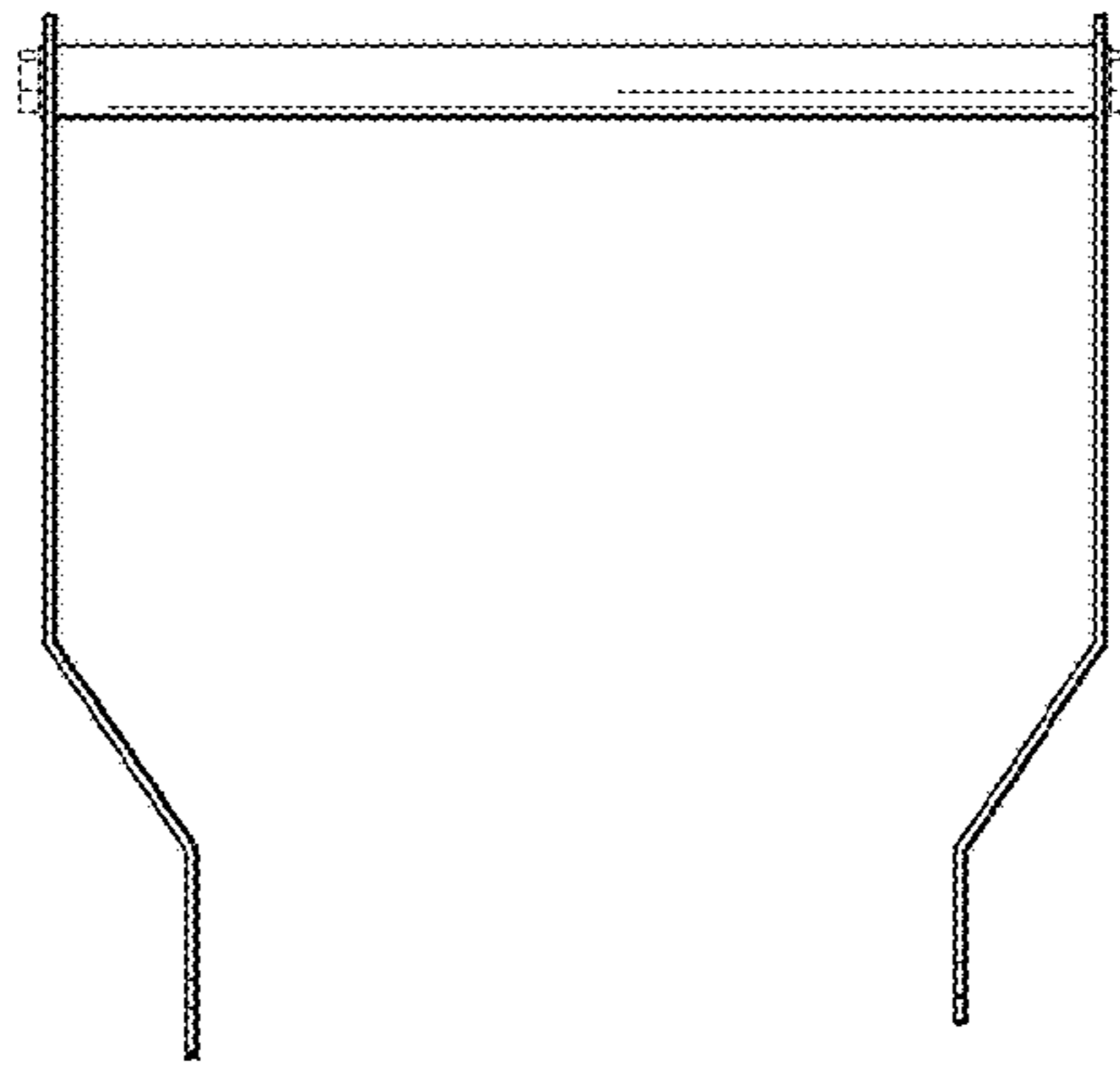

FIG. 9

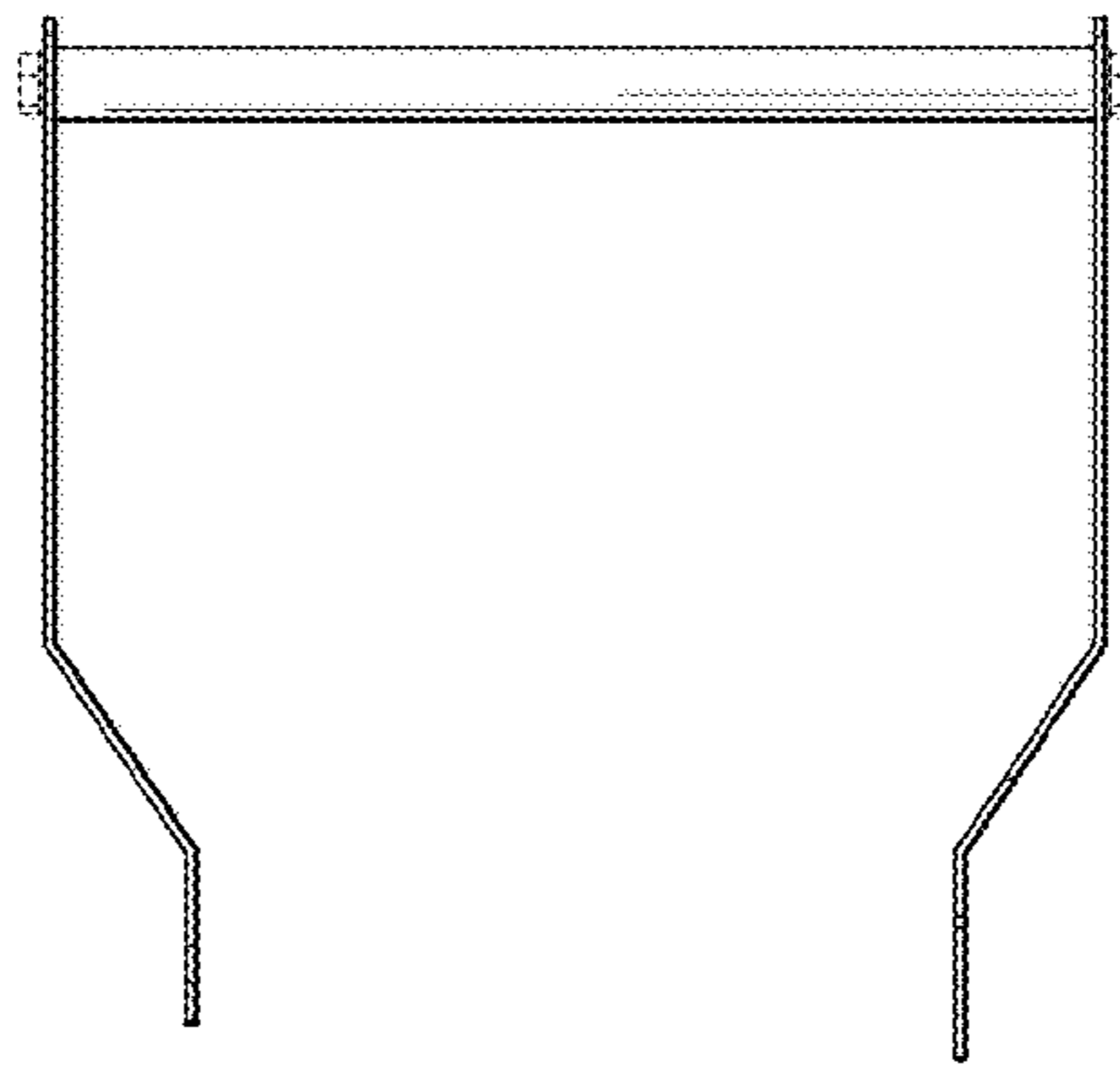

FIG. 10