



US00D849686S

(12) **United States Design Patent** (10) **Patent No.:** **US D849,686 S**
Byrne et al. (45) **Date of Patent:** **** May 28, 2019**

(54) **ELECTRICAL POWER UNIT**
(71) Applicants: **Norman R. Byrne**, Ada, MI (US);
Daniel P. Byrne, Lowell, MI (US);
Melissa A. Kilts, Greenville, MI (US)
(72) Inventors: **Norman R. Byrne**, Ada, MI (US);
Daniel P. Byrne, Lowell, MI (US);
Melissa A. Kilts, Greenville, MI (US)

(**) Term: **15 Years**
(21) Appl. No.: **29/567,250**
(22) Filed: **Jun. 7, 2016**

Related U.S. Application Data

(62) Division of application No. 29/516,863, filed on Feb. 6, 2015, now Pat. No. Des. 761,732.
(51) **LOC (11) Cl.** **13-03**
(52) **U.S. Cl.**
USPC **D13/137.2**
(58) **Field of Classification Search**
USPC D13/137.1-137.4, 138.1-138.2,
D13/139.1-139.8, 110, 133, 108, 152,
D13/184, 154, 147, 103; D14/422;
174/55; 307/23; 439/651
CPC .. H05K 7/1492; H01R 13/6272; H01R 31/06;
A47B 21/06
See application file for complete search history.

(56) **References Cited**

U.S. PATENT DOCUMENTS

676,622 A 6/1901 Gochnauer
2,811,574 A 10/1957 Guerrero
2,861,857 A 11/1958 Lee
3,049,688 A 8/1962 Sinopoli
D195,463 S 6/1963 Tamarin
3,131,512 A 5/1964 MacLeod, Jr.
3,353,137 A 11/1967 Miller
3,433,886 A 3/1969 Myers
3,622,684 A 11/1971 Press
3,646,244 A 2/1972 Cole
3,794,956 A 2/1974 Dubreuil

3,892,095 A 7/1975 Vankuik
3,972,579 A 8/1976 Kohaut
3,992,070 A 11/1976 Dunn
4,059,321 A 11/1977 Rasmussen
4,240,688 A 12/1980 Sotolongo
4,272,643 A 6/1981 Carroll
4,323,723 A 4/1982 Fork et al.
4,372,629 A 2/1983 Propst
4,463,998 A 8/1984 Reavis et al.
4,551,198 A 11/1985 Wiley
4,551,577 A 11/1985 Byrne
D288,298 S 2/1987 Yang
4,747,788 A 5/1988 Byrne
4,792,881 A 12/1988 Wilson
4,828,513 A 5/1989 Morrison
D301,576 S 6/1989 Wang
D306,012 S 2/1990 Oesterheld et al.
4,967,041 A 10/1990 Bowman
4,984,982 A 1/1991 Brownlie
4,986,762 A 1/1991 Keith
5,023,396 A 6/1991 Bartee
5,114,365 A 5/1992 Thompson
5,122,069 A 6/1992 Brownlie
5,195,288 A 5/1993 Penczak
5,230,552 A 6/1993 Schipper
5,231,562 A 6/1993 Pierce
D350,939 S 9/1994 Rossman et al.
5,351,173 A 9/1994 Byrne
D353,363 S 12/1994 Toby
D355,890 S 2/1995 Lentz
5,387,761 A 2/1995 Simonis
D368,893 S 4/1996 Harwood et al.
5,516,298 A 5/1996 Smith
D370,622 S 6/1996 Byrne
D372,018 S 7/1996 Byrne
5,566,053 A 10/1996 Chou
D382,855 S 8/1997 Salmond et al.
D389,459 S 1/1998 Byrne
5,705,772 A 1/1998 Brown
5,709,156 A 1/1998 Gevaert
D392,254 S 3/1998 Gevaert
5,738,548 A 4/1998 Rutulante
5,748,424 A 5/1998 Hung
5,757,668 A 5/1998 Zhu
5,765,932 A 6/1998 Domina et al.
D401,220 S * 11/1998 Dwight D13/139.6
D401,555 S * 11/1998 Tam D13/137.3
D405,416 S 2/1999 Byrne
D407,374 S 3/1999 Byrne
D412,698 S 8/1999 Byrne
D413,571 S 9/1999 Glass
5,964,618 A 10/1999 McCarthy
5,984,728 A 11/1999 Chen et al.

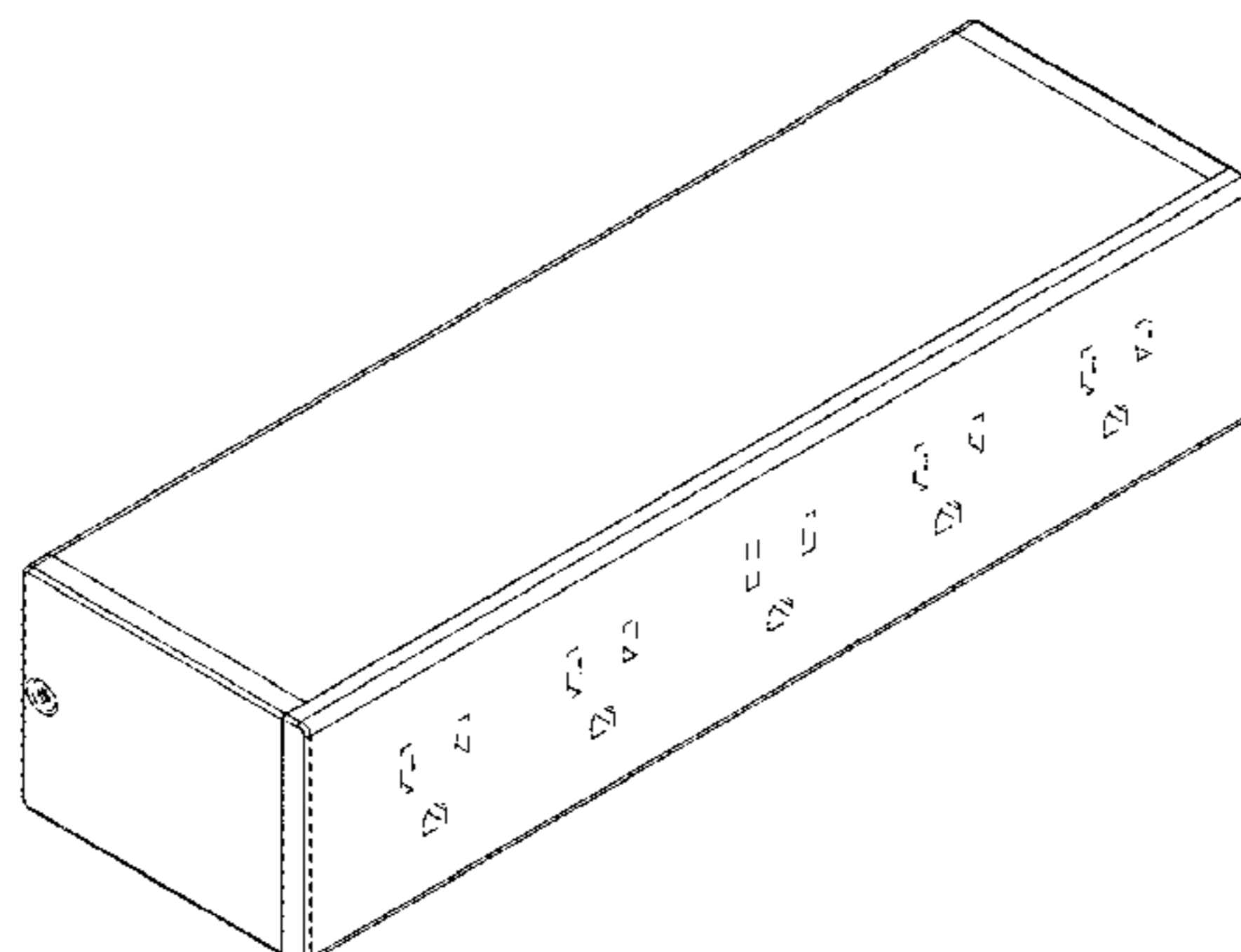

6,004,157	A	12/1999	Glass	
6,028,267	A	2/2000	Byrne	
6,081,356	A	6/2000	Branc et al.	
D427,454	S *	7/2000	Munch	D13/184
D436,922	S	1/2001	Stekelenburg	
6,220,880	B1	4/2001	Lee et al.	
6,200,159	B1	5/2001	Chou	
D444,126	S	6/2001	Chura et al.	
D445,403	S *	7/2001	Veino	D13/139.8
D446,188	S	8/2001	Gershfeld	
D446,189	S	8/2001	Lee	
D446,503	S	8/2001	Lee	
D446,504	S	8/2001	Lee	
6,290,518	B1	9/2001	Byrne	
D449,819	S	10/2001	Gershfeld	
6,379,182	B1	4/2002	Byrne	
D457,137	S	5/2002	Gershfeld	
6,386,921	B1 *	5/2002	Casari	H01R 31/06 439/651
D464,627	S	10/2002	Metcalf	
D467,875	S	12/2002	Barger et al.	
6,492,591	B1	12/2002	Metcalf	
D470,460	S *	2/2003	Yu	D13/139.8
D472,213	S	3/2003	Byrne	
D484,098	S	12/2003	Lee	
D486,793	S	2/2004	Gershfeld	
6,717,053	B2	4/2004	Rupert	
6,830,477	B2	12/2004	Vander Vorste et al.	
6,875,051	B2	4/2005	Pizak	
D505,917	S *	6/2005	Murphy	D13/139.6
6,971,911	B2	12/2005	Ramsey et al.	
7,001,211	B2	2/2006	Lichtscheidl et al.	
7,083,421	B1	8/2006	Mori	
D528,508	S	9/2006	Tan et al.	
7,112,097	B1	9/2006	Lam	
D535,257	S	1/2007	Byrne	
7,223,122	B2	5/2007	Mori	
D558,676	S	1/2008	Fort et al.	
D591,233	S	4/2009	Kagami et al.	
D611,428	S *	3/2010	Chapman	D13/154
7,736,178	B2	6/2010	Byrne	
D626,071	S	10/2010	Su et al.	
D636,345	S *	4/2011	Cullen	D13/137.4
D636,728	S	4/2011	Terleski et al.	
D642,983	S *	8/2011	Finlayson	D13/147
D643,807	S *	8/2011	Jiang	D13/103
D649,515	S *	11/2011	Ullrich	D13/139.8
D651,974	S	1/2012	Benedetti	
D653,215	S	1/2012	Lam	
D654,432	S *	2/2012	Brookshire	D13/110
8,221,158	B2	7/2012	Liao	
D665,355	S	8/2012	Byrne	
8,283,802	B2 *	10/2012	Jansma	H01R 13/6272 307/23
8,287,292	B2	10/2012	Byrne	
D673,909	S *	1/2013	Zaslavsky	D13/110
D674,754	S	1/2013	Zanoni et al.	
D681,551	S *	5/2013	Zaslavsky	D13/110
D682,789	S *	5/2013	Au	D13/137.3
8,480,429	B2	7/2013	Byrne	
8,496,492	B2	7/2013	Byrne	
D692,825	S	11/2013	Izen et al.	
D693,770	S *	11/2013	Miller	D13/139.2
D701,834	S *	4/2014	Lee	D13/137.2
D702,184	S *	4/2014	Jacobs	D13/110
D714,290	S *	9/2014	Tanaka	D14/422
D736,159	S	8/2015	Byrne et al.	
9,148,006	B2	9/2015	Byrne et al.	
D744,953	S *	12/2015	Byrne	D13/139.4
D758,967	S *	6/2016	Chen	D13/110
D761,732	S *	7/2016	Byrne	D13/137.2
D762,175	S *	7/2016	Byrne	D13/137.2
D780,122	S *	2/2017	Irons	H05K 7/1492 D13/139.8
D788,709	S *	6/2017	Yeo	D13/137.2
D790,465	S *	6/2017	Zhao	D13/110
D795,190	S *	8/2017	Tzeng	D13/110
D796,437	S *	9/2017	Banayan	D13/110
2006/0258195	A1	11/2006	Schwartz et al.	

2007/0275594	A1	11/2007	Greenberg
2009/0294147	A1	12/2009	Stockton
2014/0292289	A1	10/2014	Gelonese

FOREIGN PATENT DOCUMENTS

WO WO-2009039277 A1 * 3/2009 A47B 21/06

OTHER PUBLICATIONS

Co-pending and commonly-owned Design U.S. Appl. No. 29/516,875, filed Feb. 6, 2015, including replacement drawings filed by Preliminary Amendment on Oct. 30, 2015.

Co-pending and commonly-owned Design U.S. Appl. No. 29/516,863, filed Feb. 6, 2015, including replacement drawings filed by Preliminary Amendment on Oct. 30, 2015.

* cited by examiner

Primary Examiner — Rhea Shields

(74) *Attorney, Agent, or Firm* — Gardner, Linn, Burkhardt & Ondersma LLP

(57) CLAIM

The ornamental design for an electrical power unit, as shown and described.

DESCRIPTION

FIG. 1 is a front perspective view of a first embodiment of the electrical power unit and showing our new design; FIG. 2 is a rear perspective view thereof; FIG. 3 is a front elevation thereof; FIG. 4 is a rear elevation thereof; FIG. 5 is a top plan view thereof; FIG. 6 is a bottom plan view thereof; FIG. 7 is a right side elevation thereof; FIG. 8 is a left side elevation thereof; FIG. 9 is a front perspective view of a second embodiment of the electrical power unit and showing our new design; FIG. 10 is a rear perspective view thereof; FIG. 11 is a front elevation thereof; FIG. 12 is a rear elevation thereof; FIG. 13 is a top plan view thereof; FIG. 14 is a bottom plan view thereof; FIG. 15 is a right side elevation thereof; FIG. 16 is a left side elevation thereof; FIG. 17 is a front perspective view of a third embodiment of the electrical power unit and showing our new design; FIG. 18 is a rear perspective view thereof; FIG. 19 is a front elevation thereof; FIG. 20 is a rear elevation thereof; FIG. 21 is a top plan view thereof; FIG. 22 is a bottom plan view thereof; FIG. 23 is a right side elevation thereof; FIG. 24 is a left side elevation thereof; FIG. 25 is a front perspective view of a fourth embodiment of the electrical power unit and showing our new design; FIG. 26 is a rear perspective view thereof; FIG. 27 is a front elevation thereof; FIG. 28 is a rear elevation thereof; FIG. 29 is a top plan view thereof; FIG. 30 is a bottom plan view thereof; FIG. 31 is a right side elevation thereof; FIG. 32 is a left side elevation thereof;

FIG. 33 is a front perspective view of a fifth embodiment of the electrical power unit and showing our new design;

FIG. 34 is a rear perspective view thereof;

FIG. 35 is a front elevation thereof;

FIG. 36 is a rear elevation thereof;

FIG. 37 is a top plan view thereof;

FIG. 38 is a bottom plan view thereof;

FIG. 39 is a right side elevation thereof;

FIG. 40 is a left side elevation thereof;

FIG. 41 is a front perspective view of a sixth embodiment of the electrical power unit and showing our new design.

FIG. 42 is a rear perspective view thereof;

FIG. 43 is a front elevation thereof;

FIG. 44 is a rear elevation thereof;

FIG. 45 is a top plan view thereof;

FIG. 46 is a bottom plan view thereof;

FIG. 47 is a right side elevation thereof; and,

FIG. 48 is a left side elevation thereof.

In the drawings, the broken lines are for the purpose of illustrating environment only and form no part of the claimed design.

1 Claim, 24 Drawing Sheets

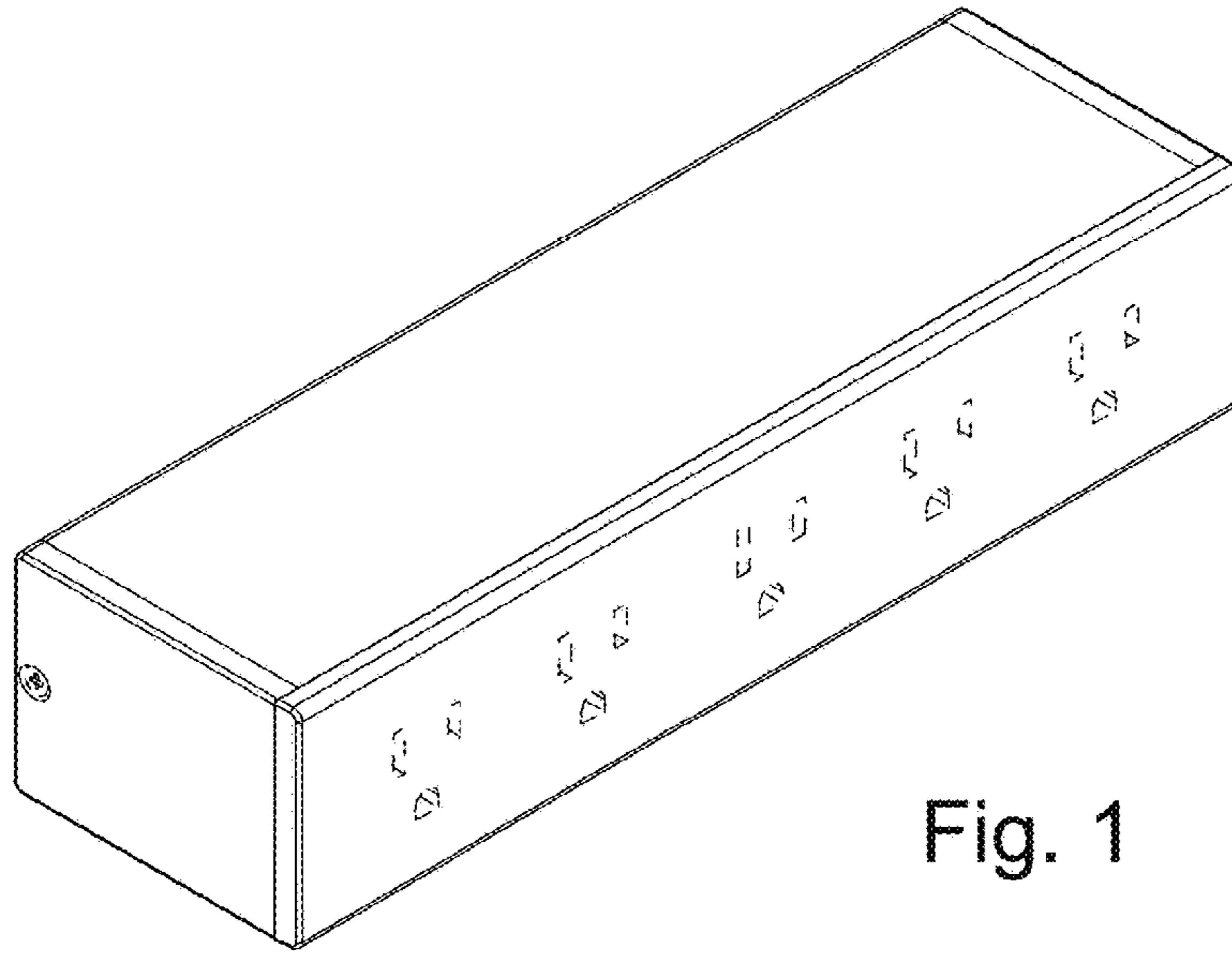

Fig. 1

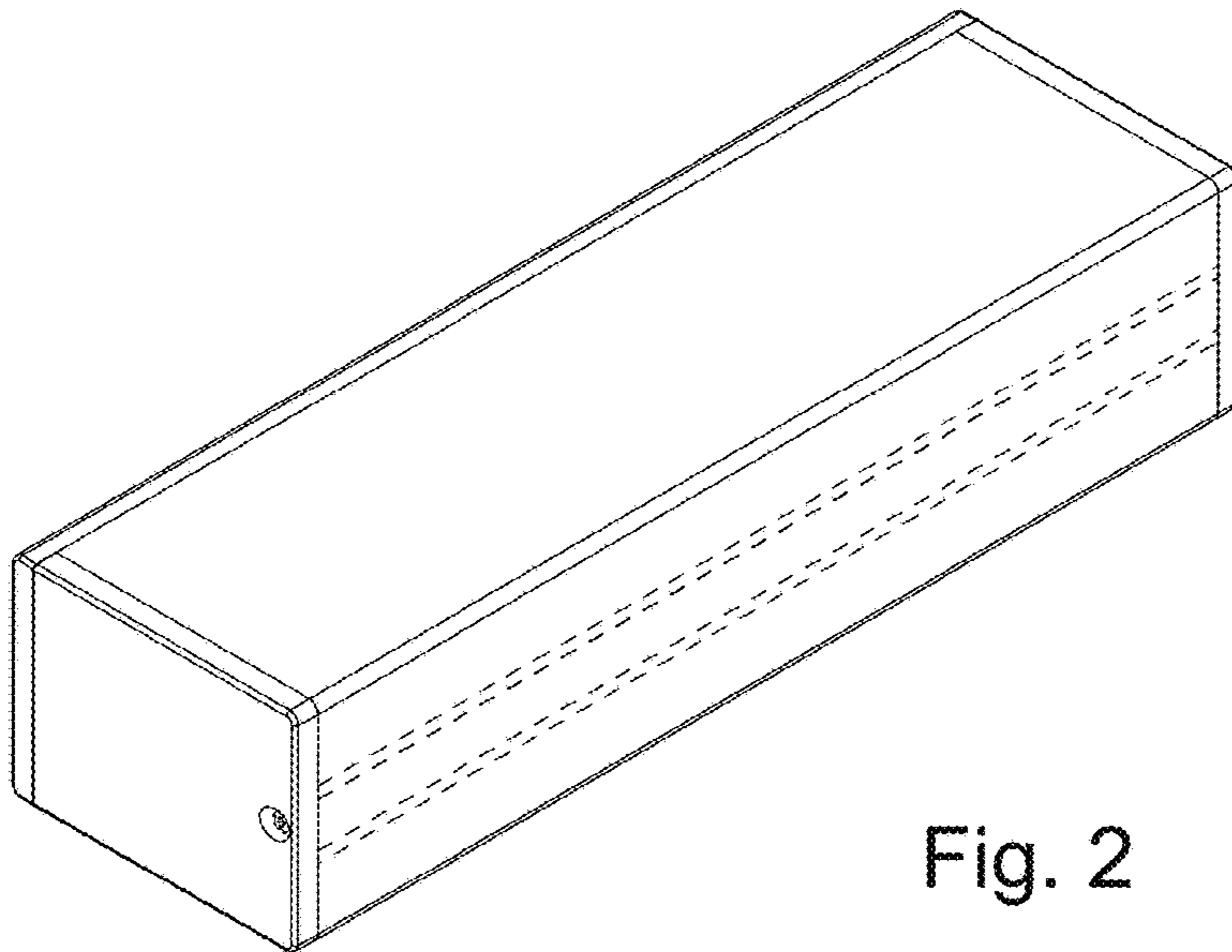

Fig. 2

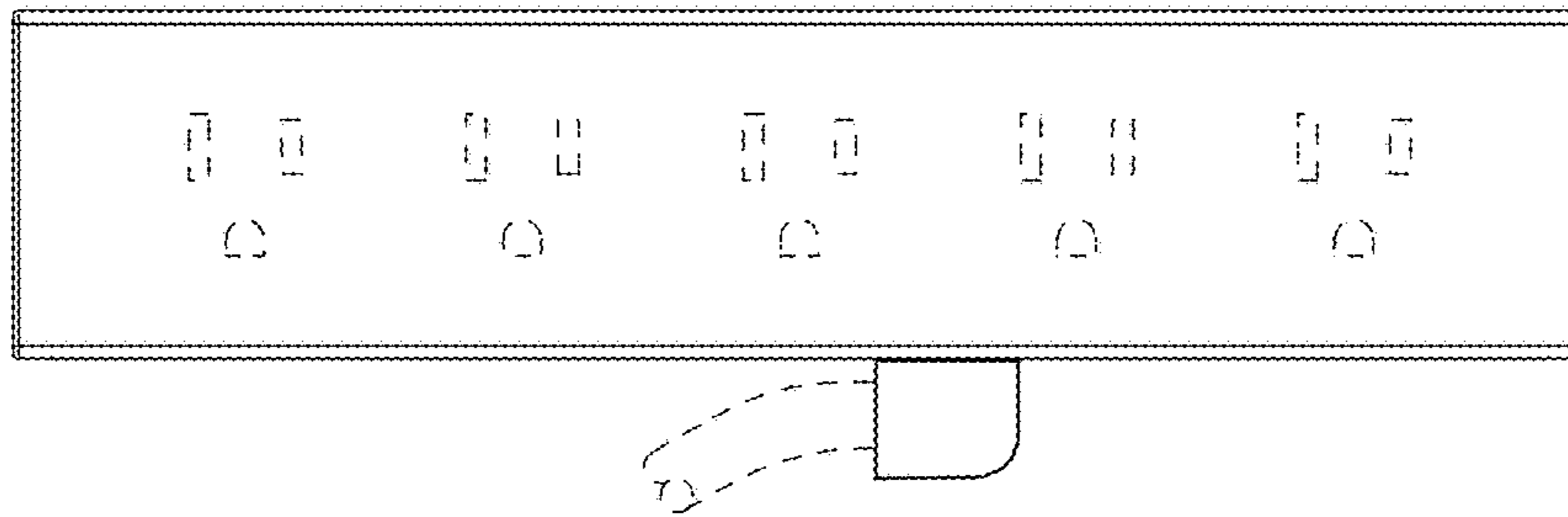

Fig. 3

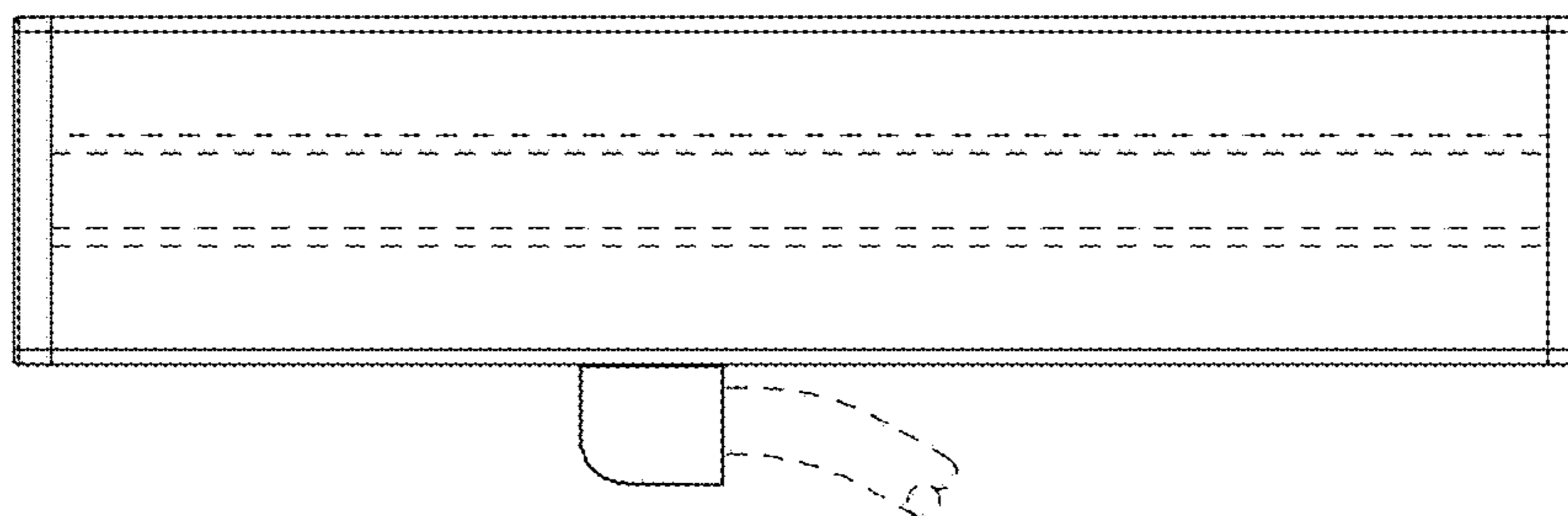

Fig. 4

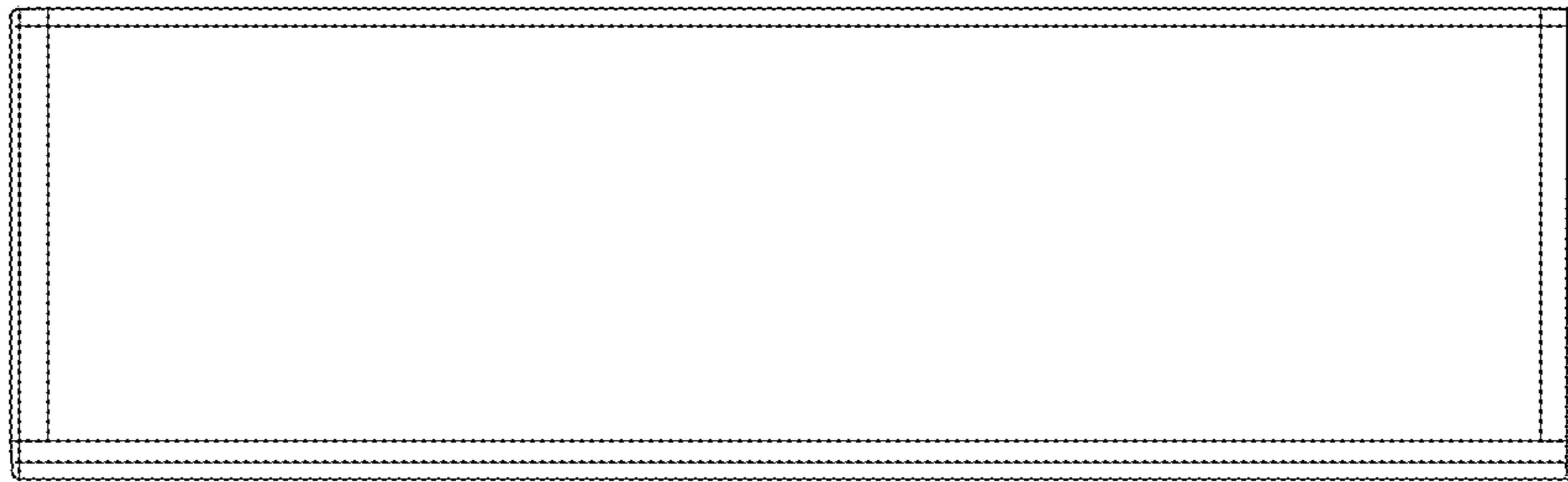

Fig. 5

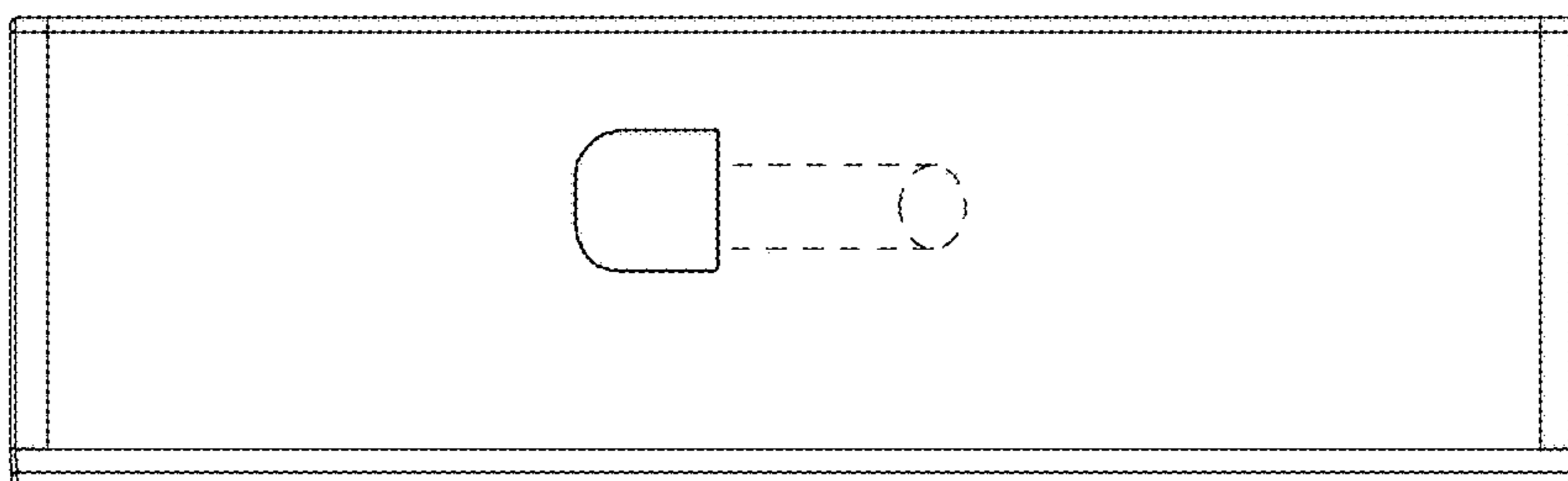

Fig. 6

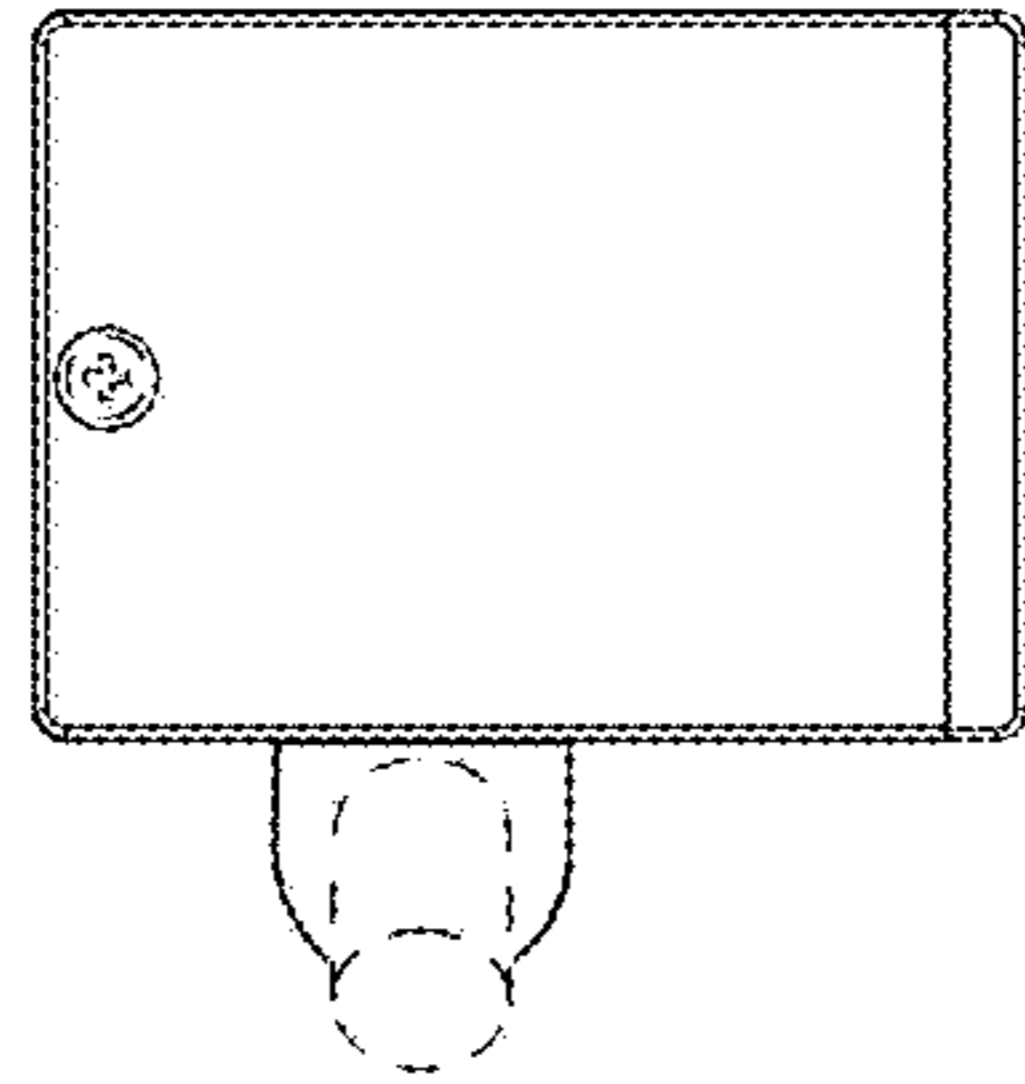

Fig. 7

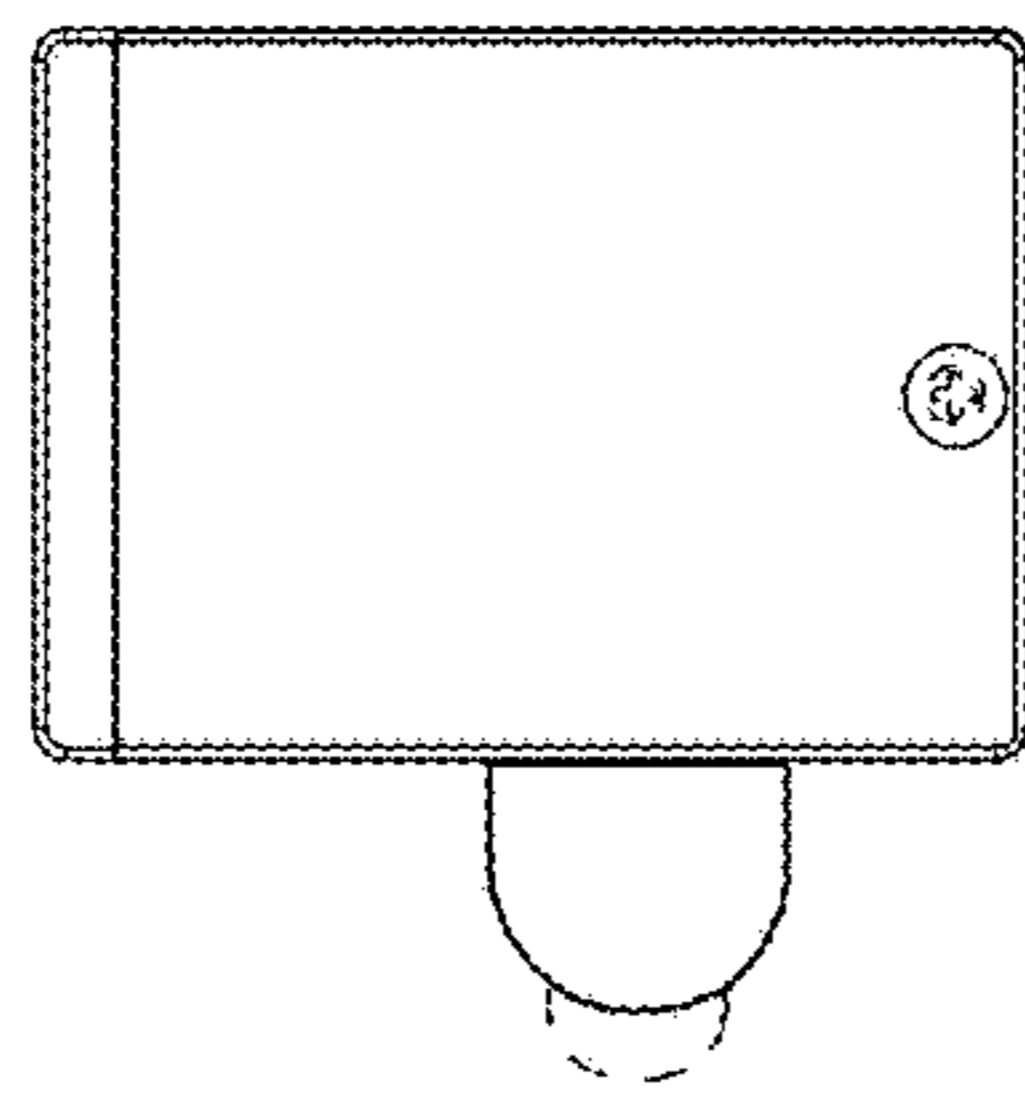

Fig. 8

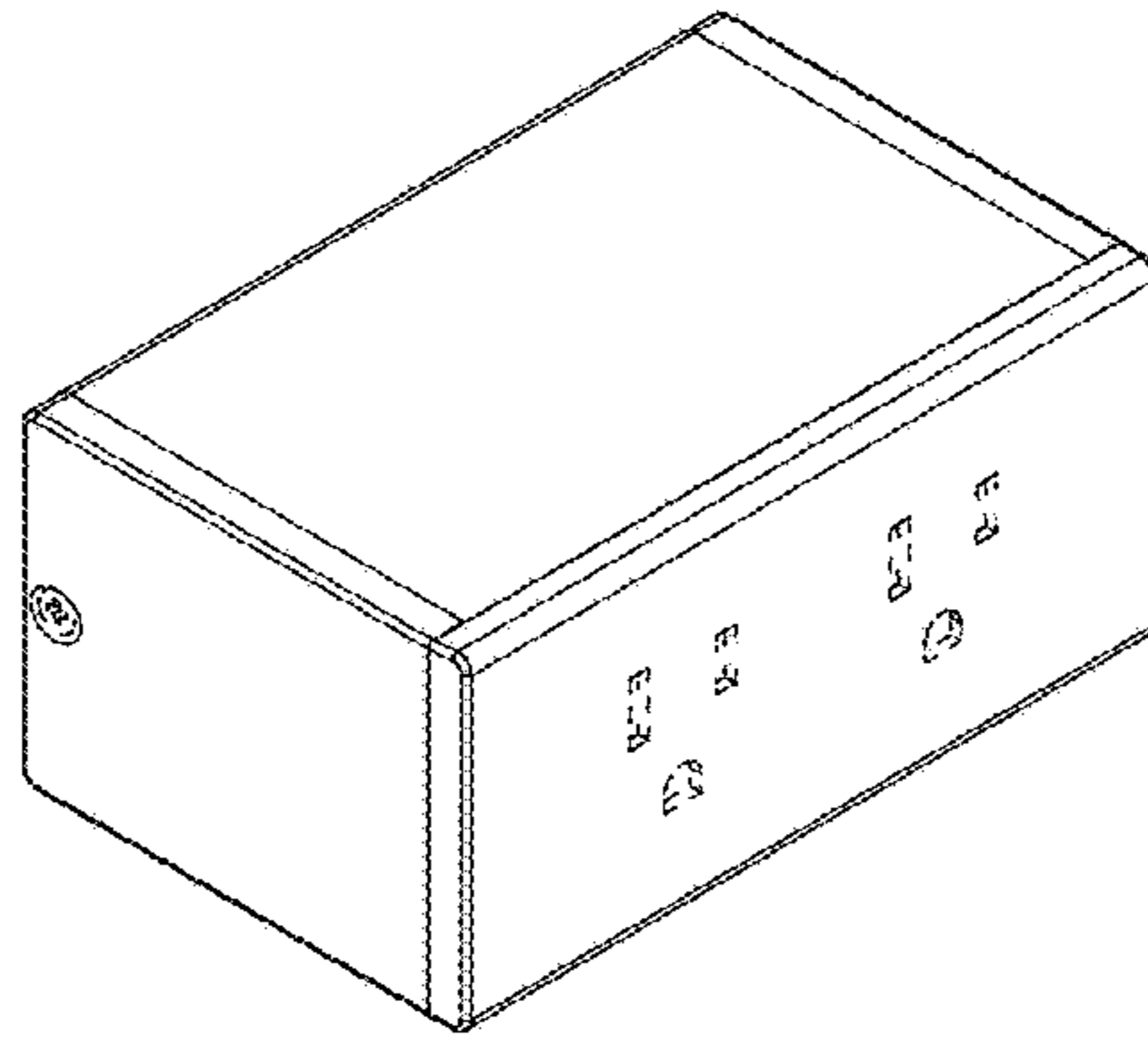

Fig. 9

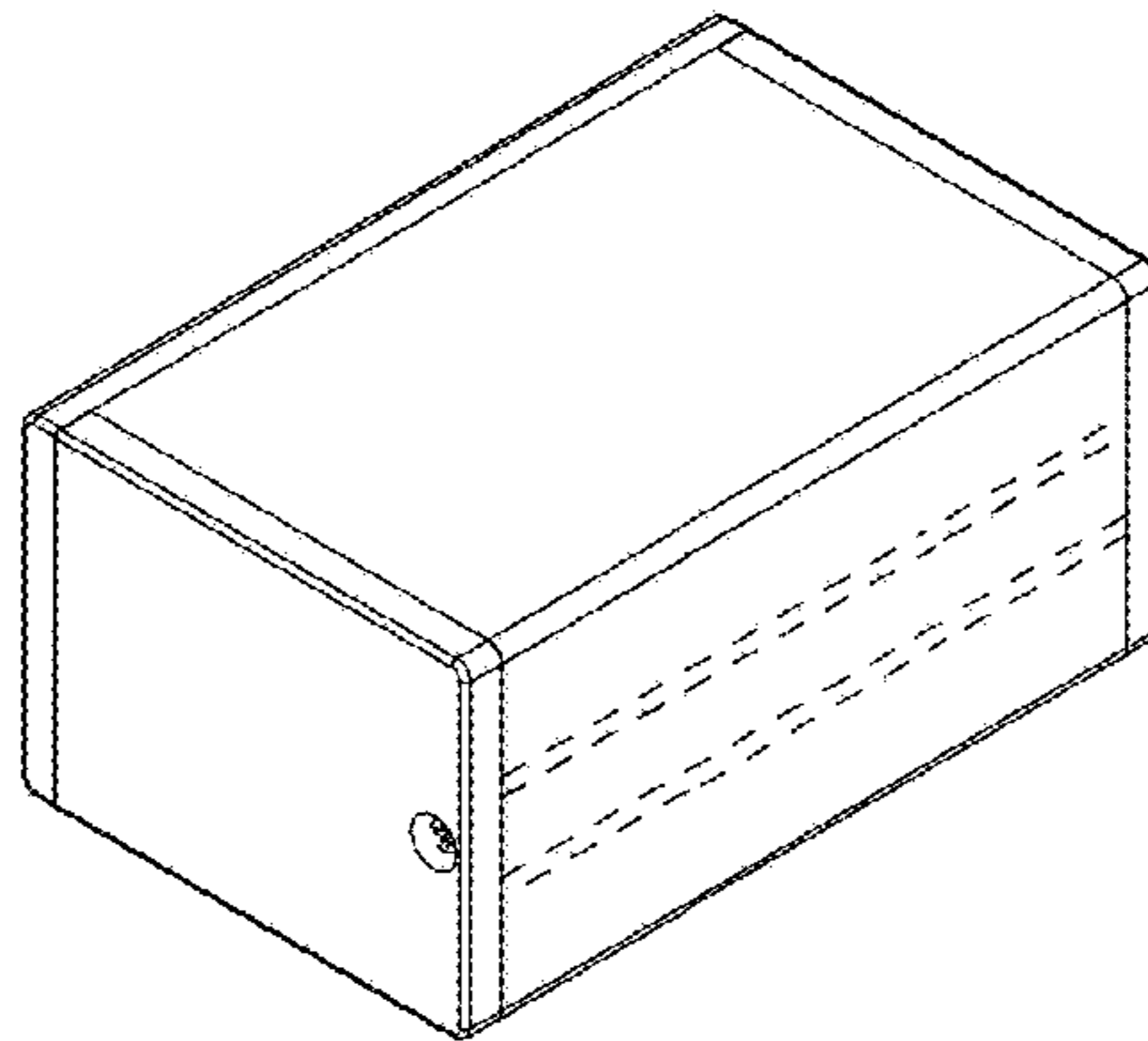

Fig. 10

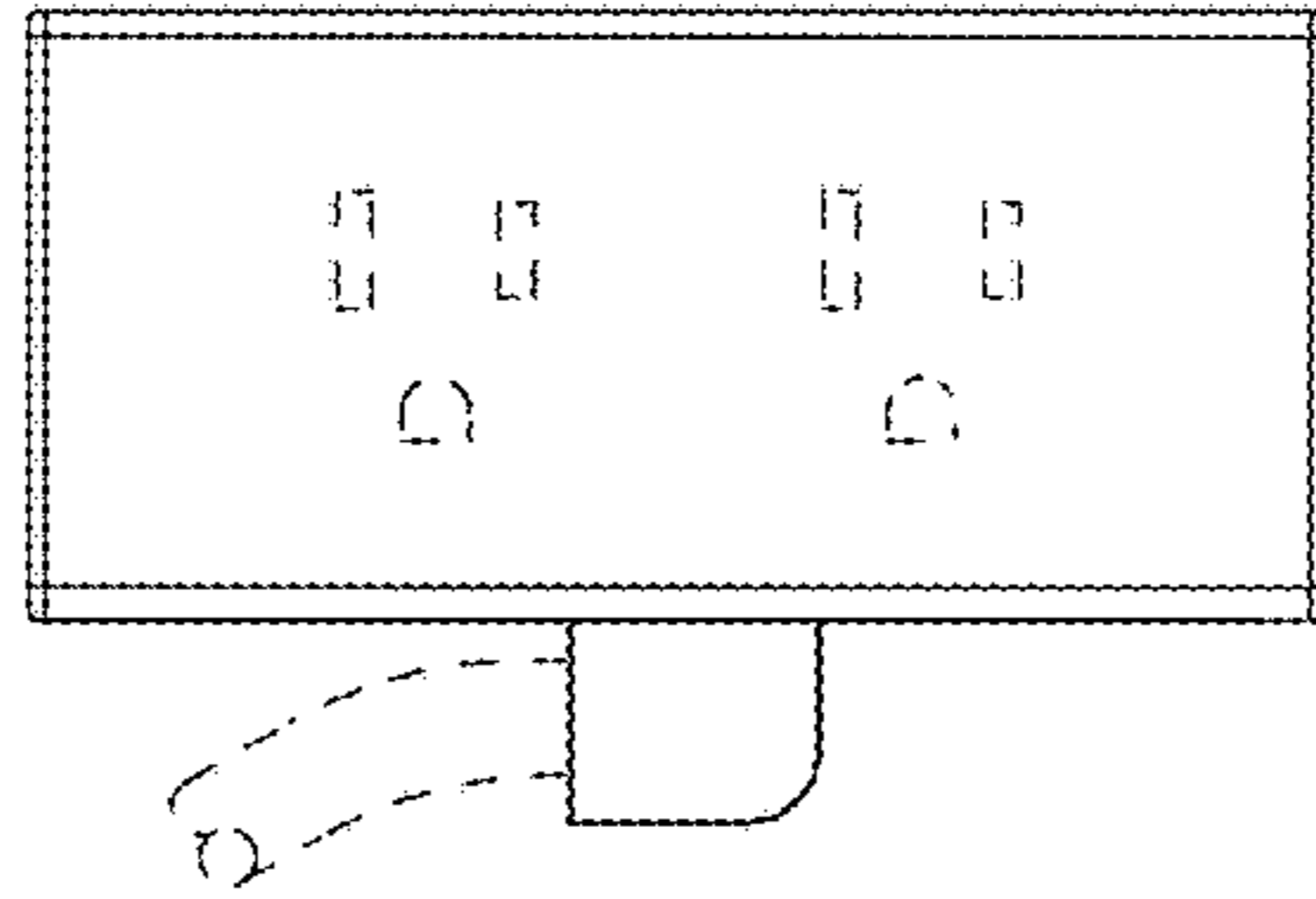

Fig. 11

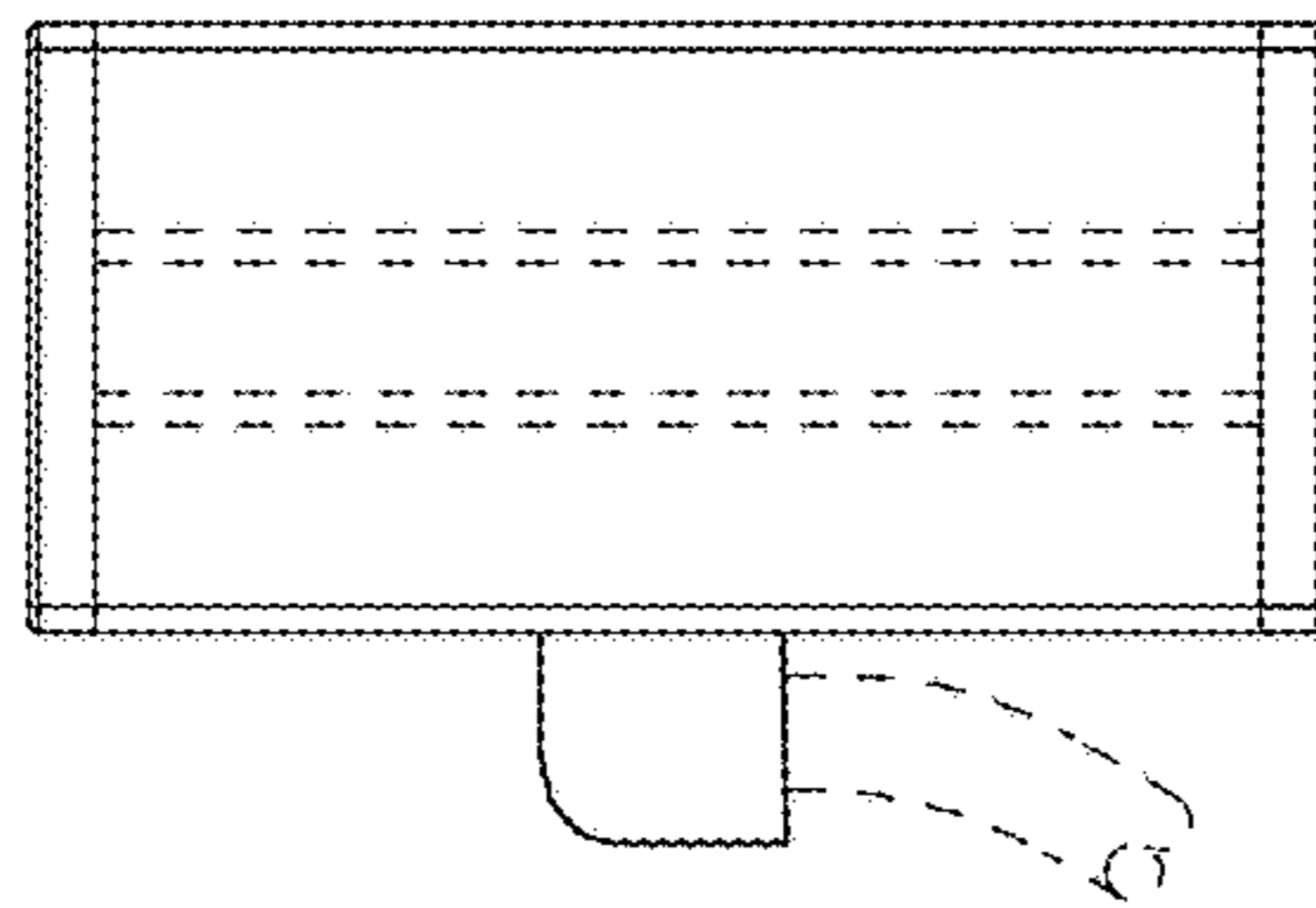

Fig. 12

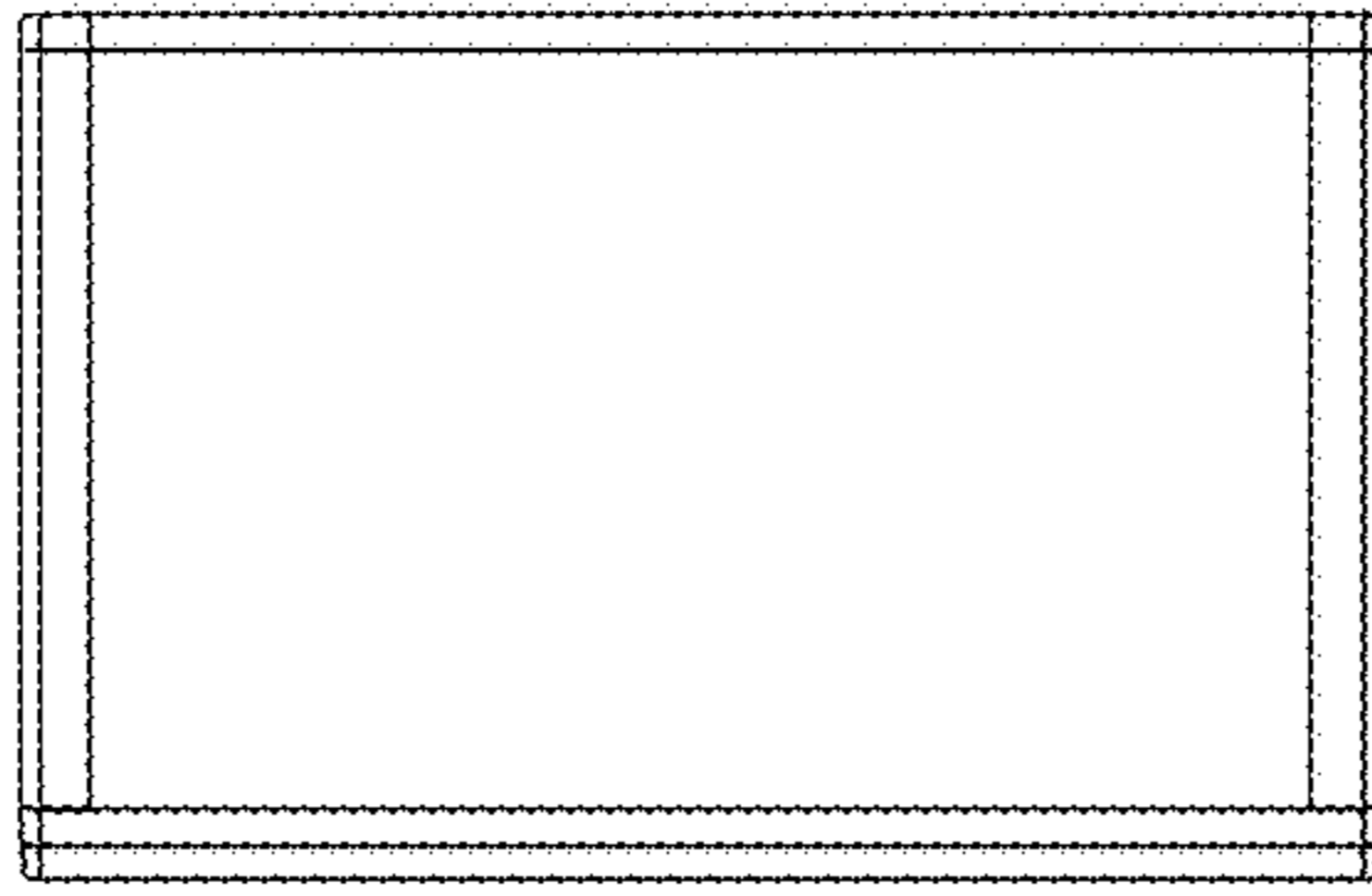

Fig. 13

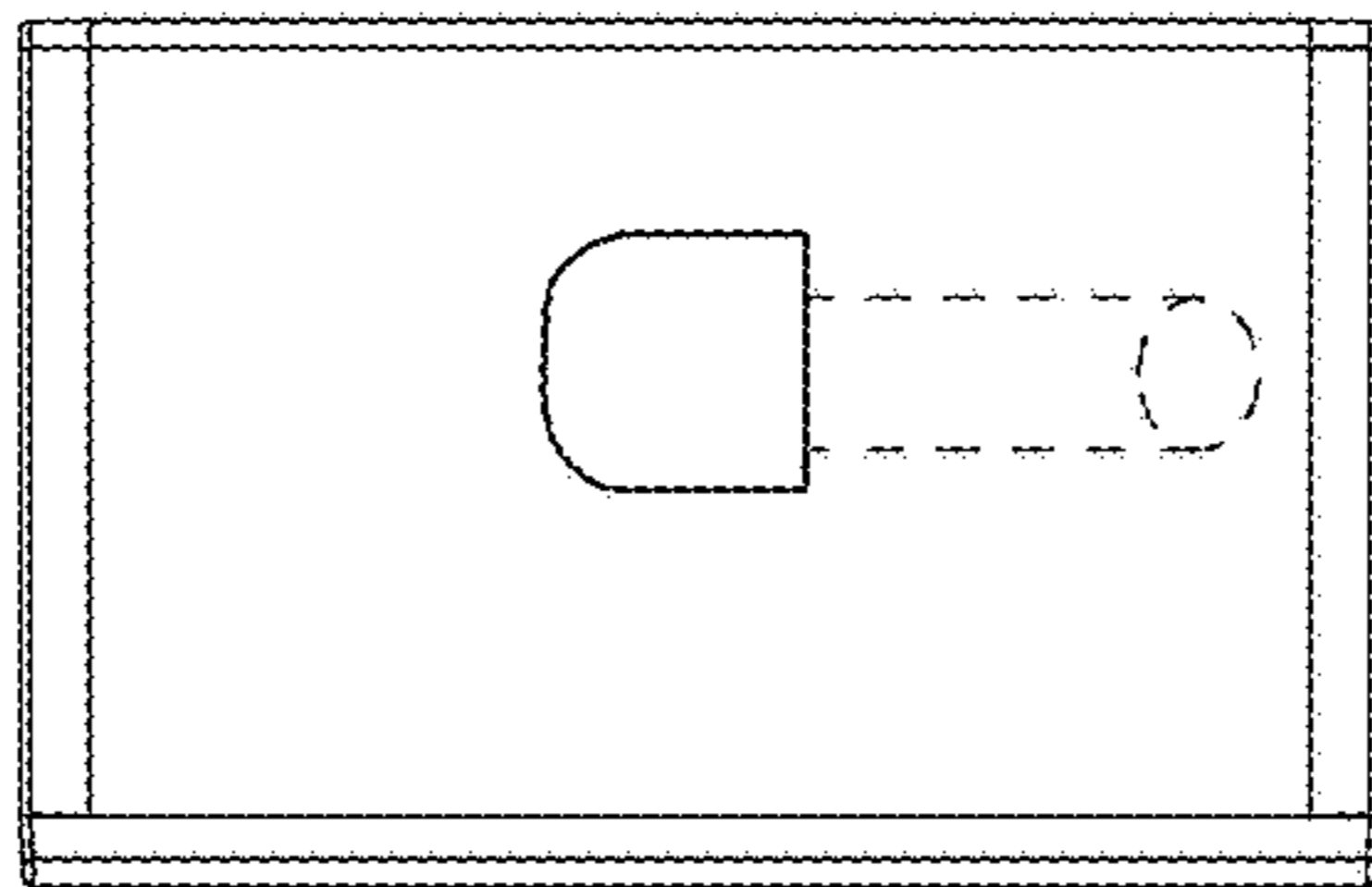

Fig. 14

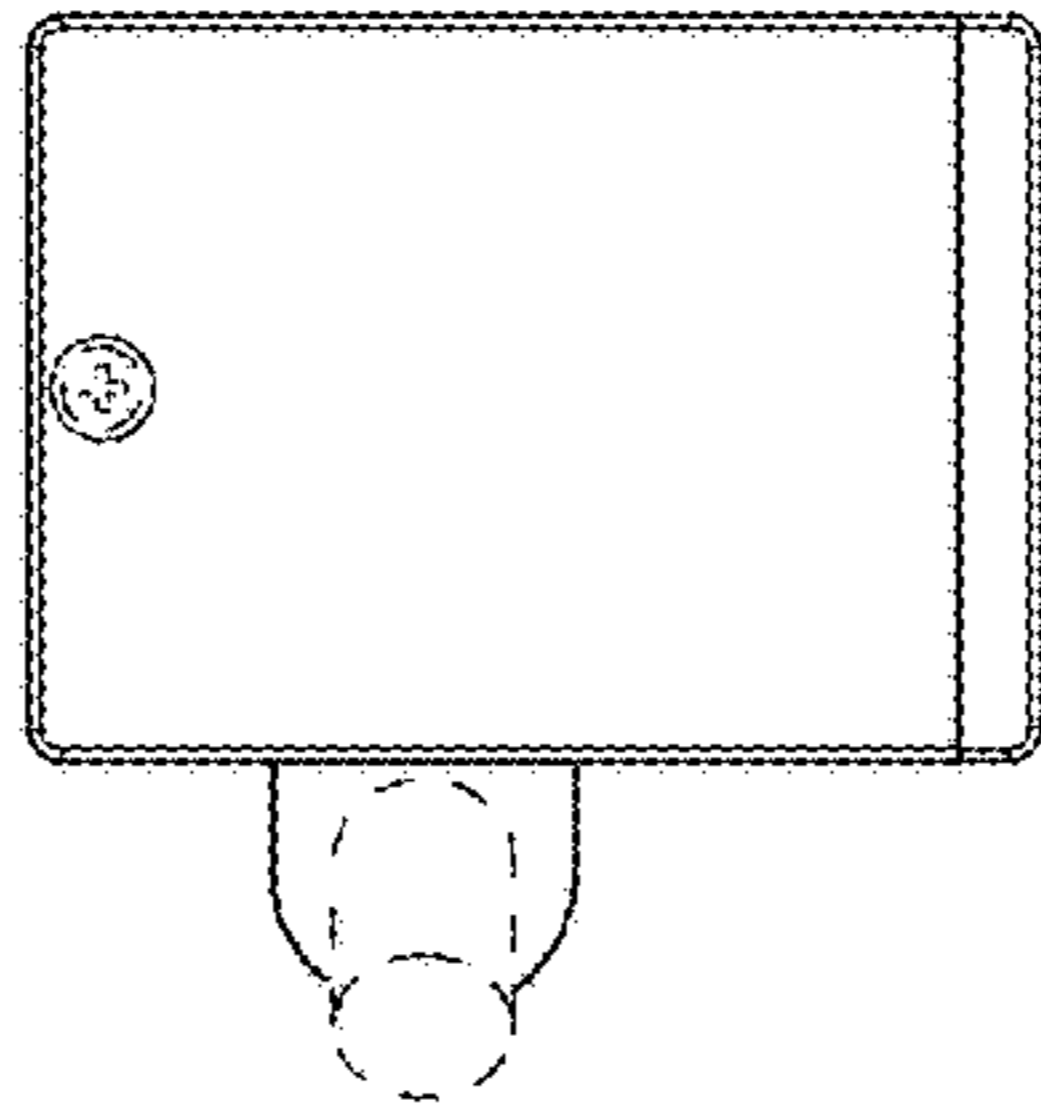

Fig. 15

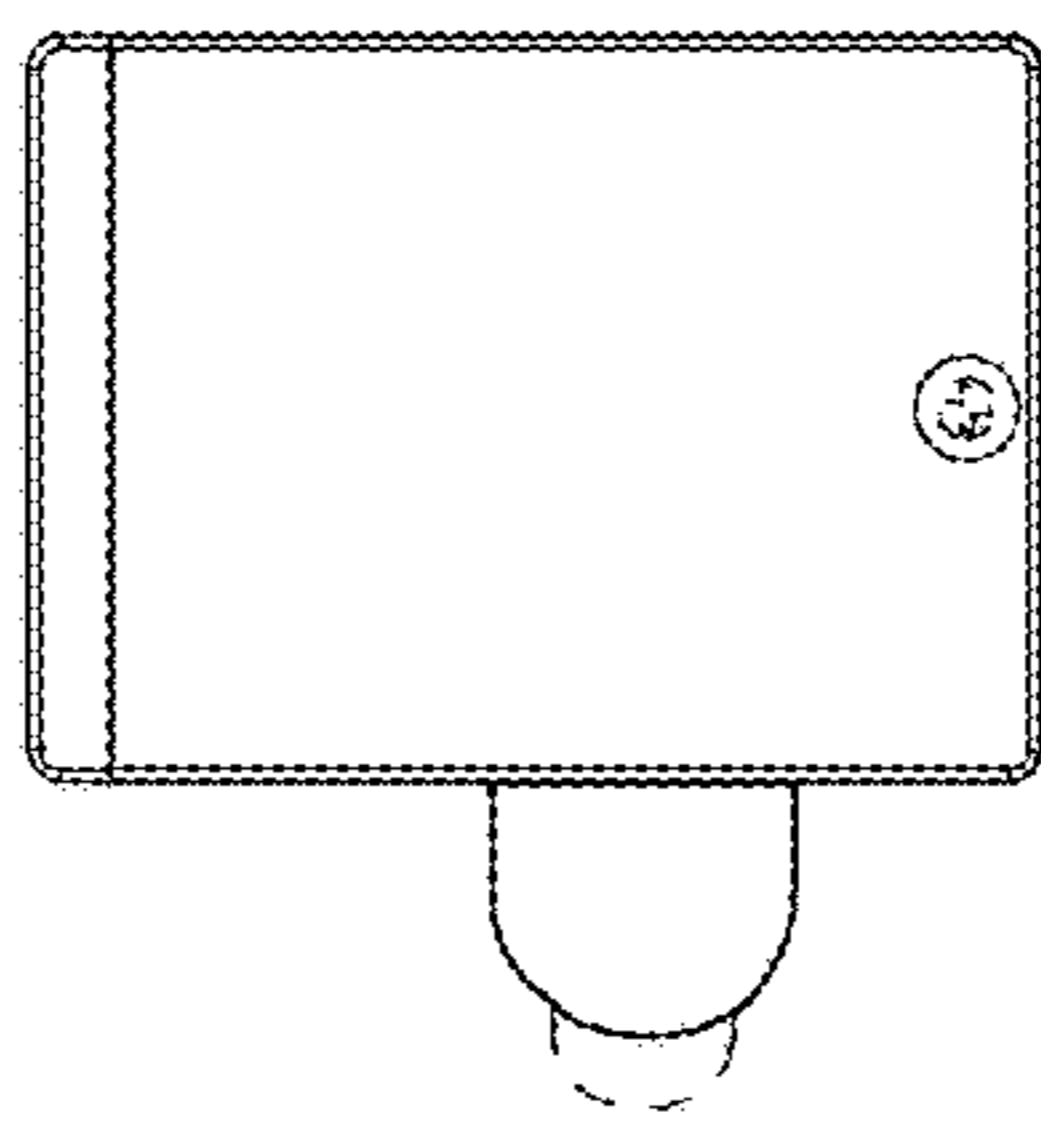

Fig. 16

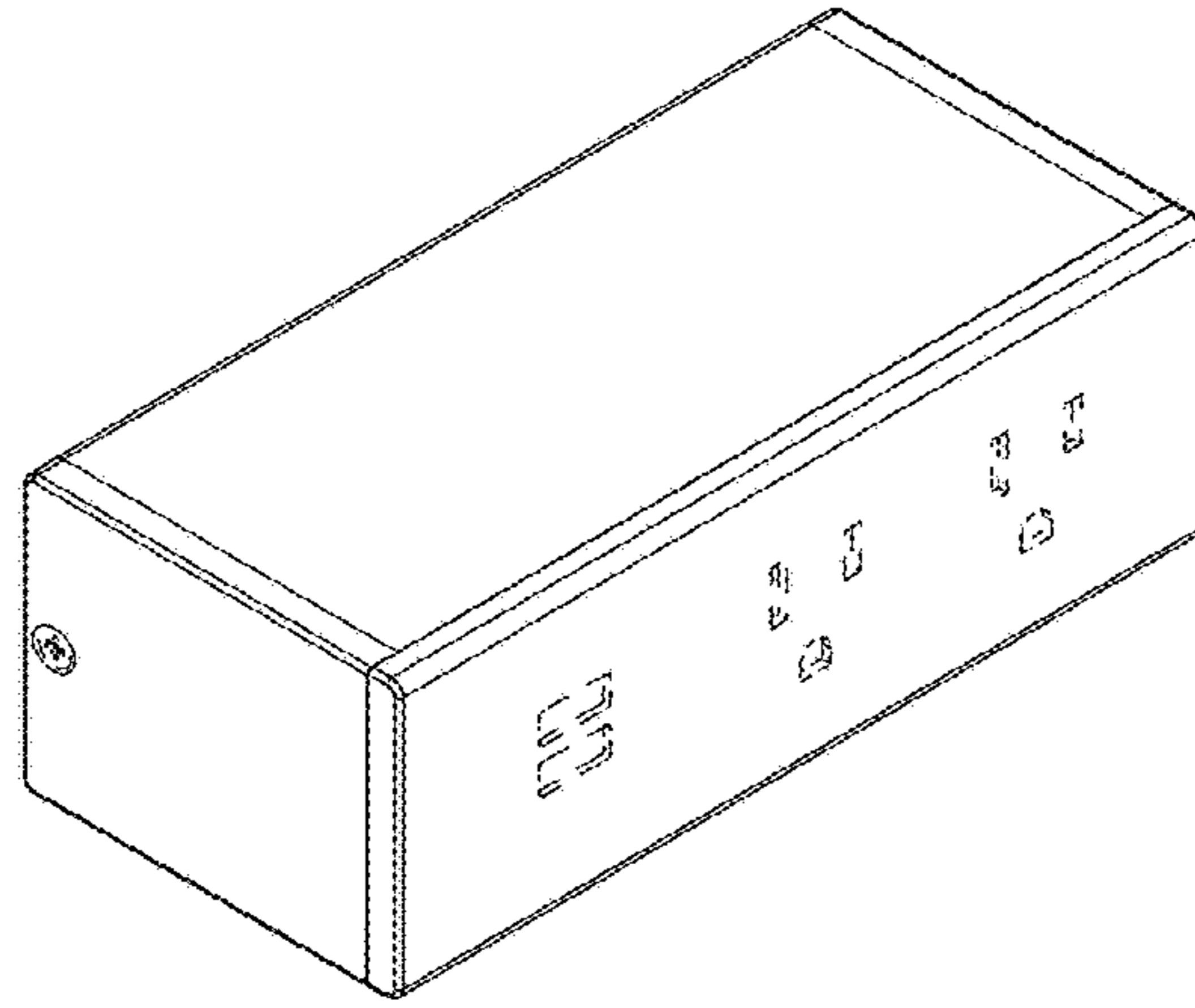

Fig. 17

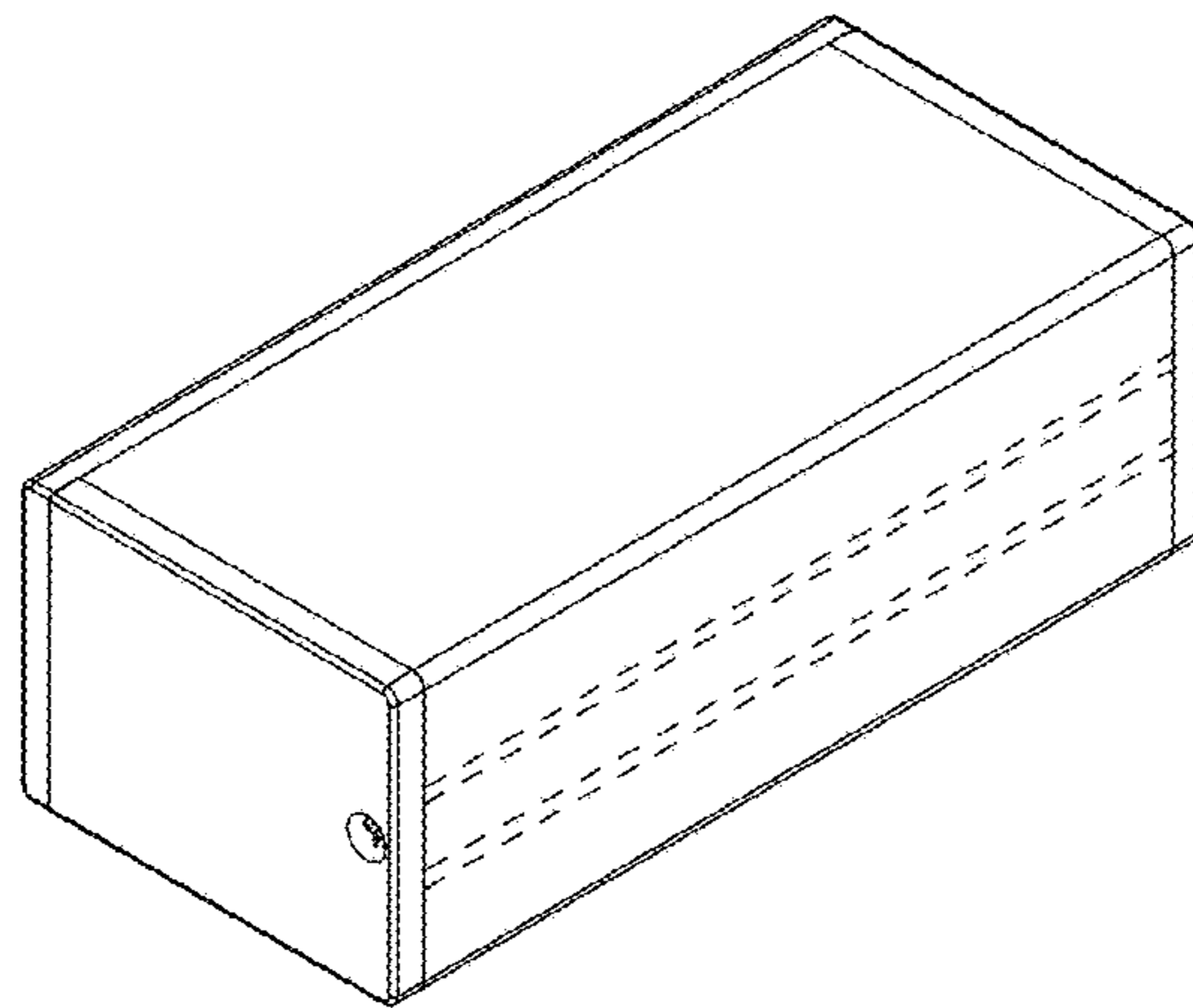

Fig. 18

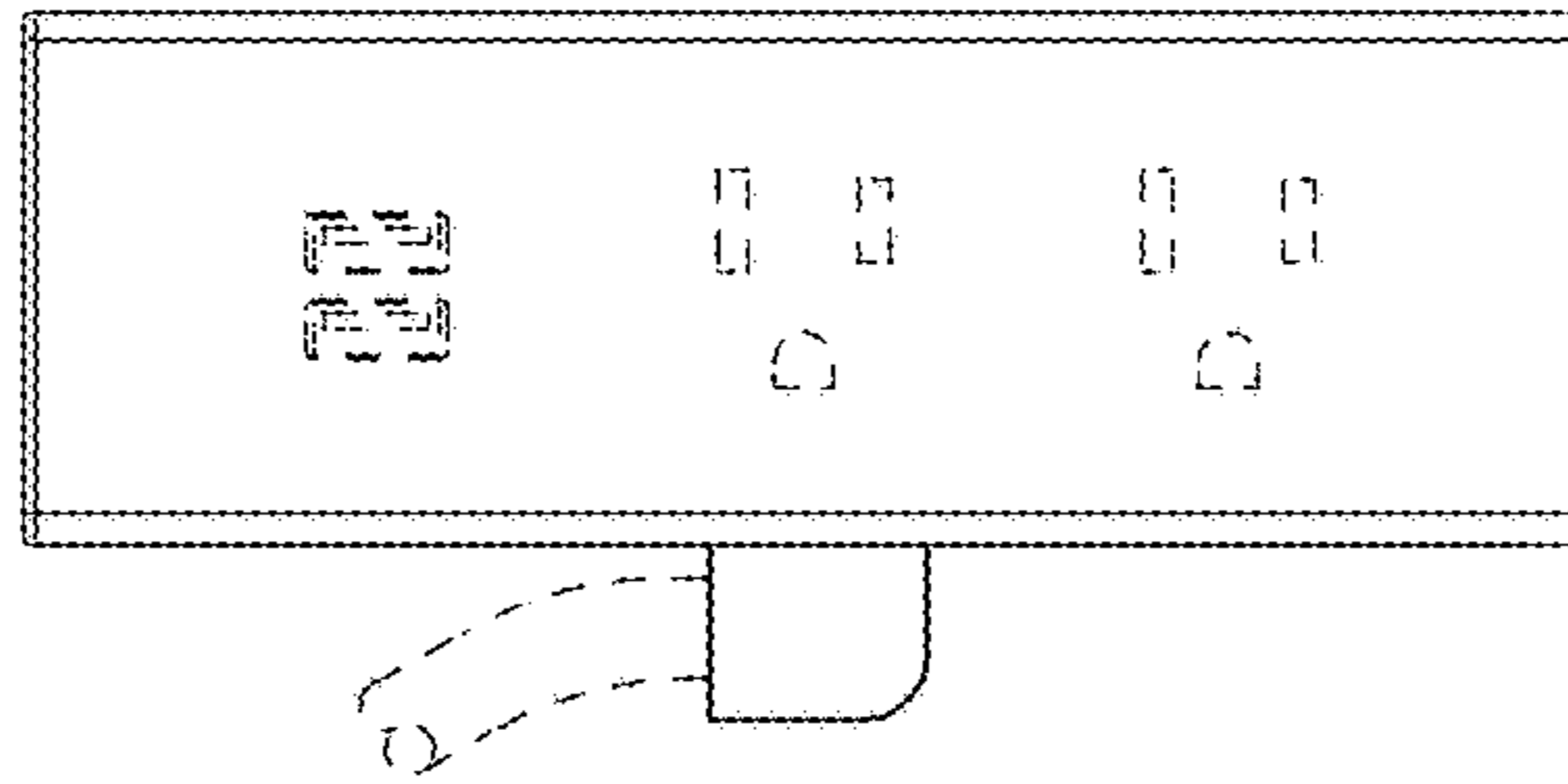

Fig. 19

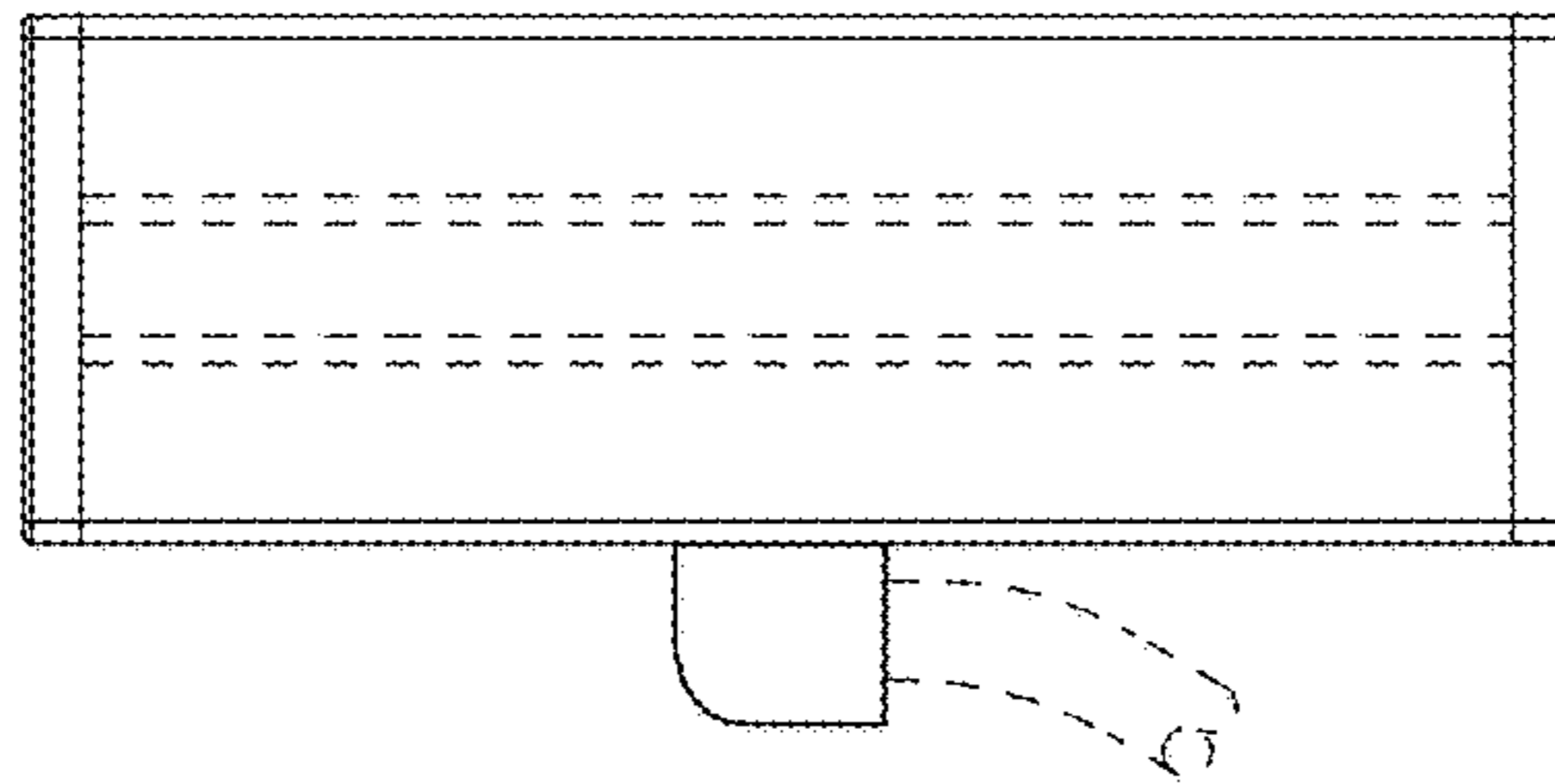

Fig. 20

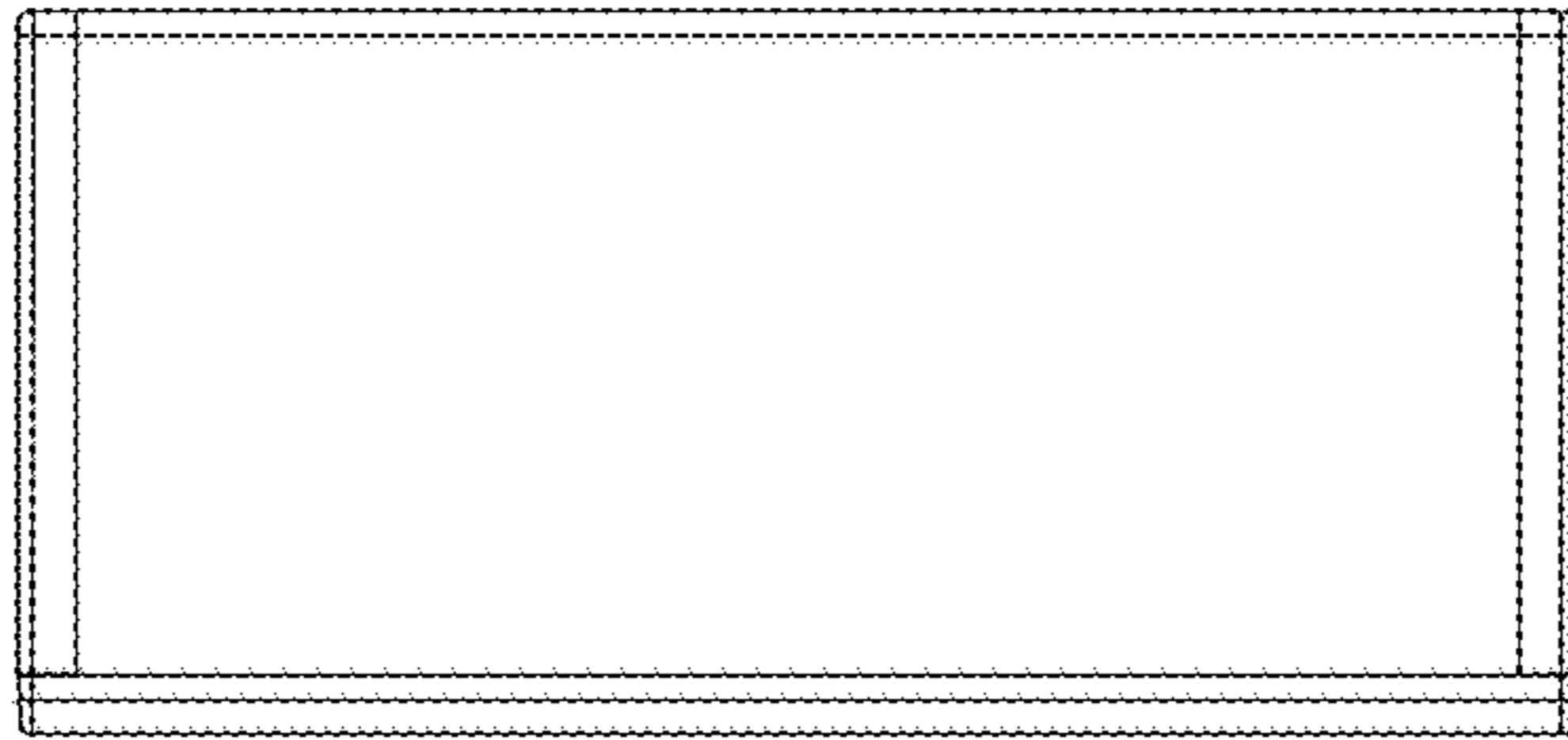

Fig. 21

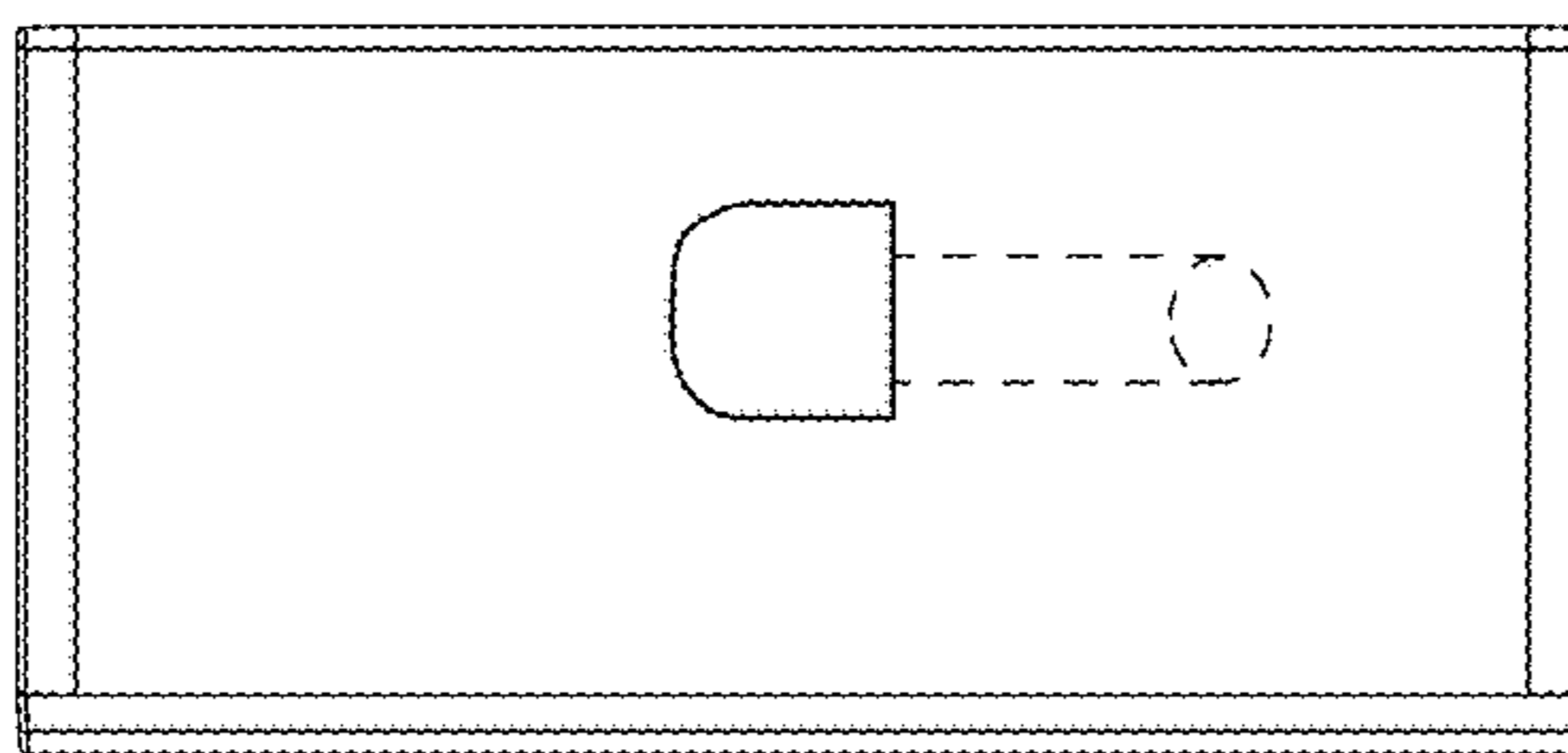

Fig. 22

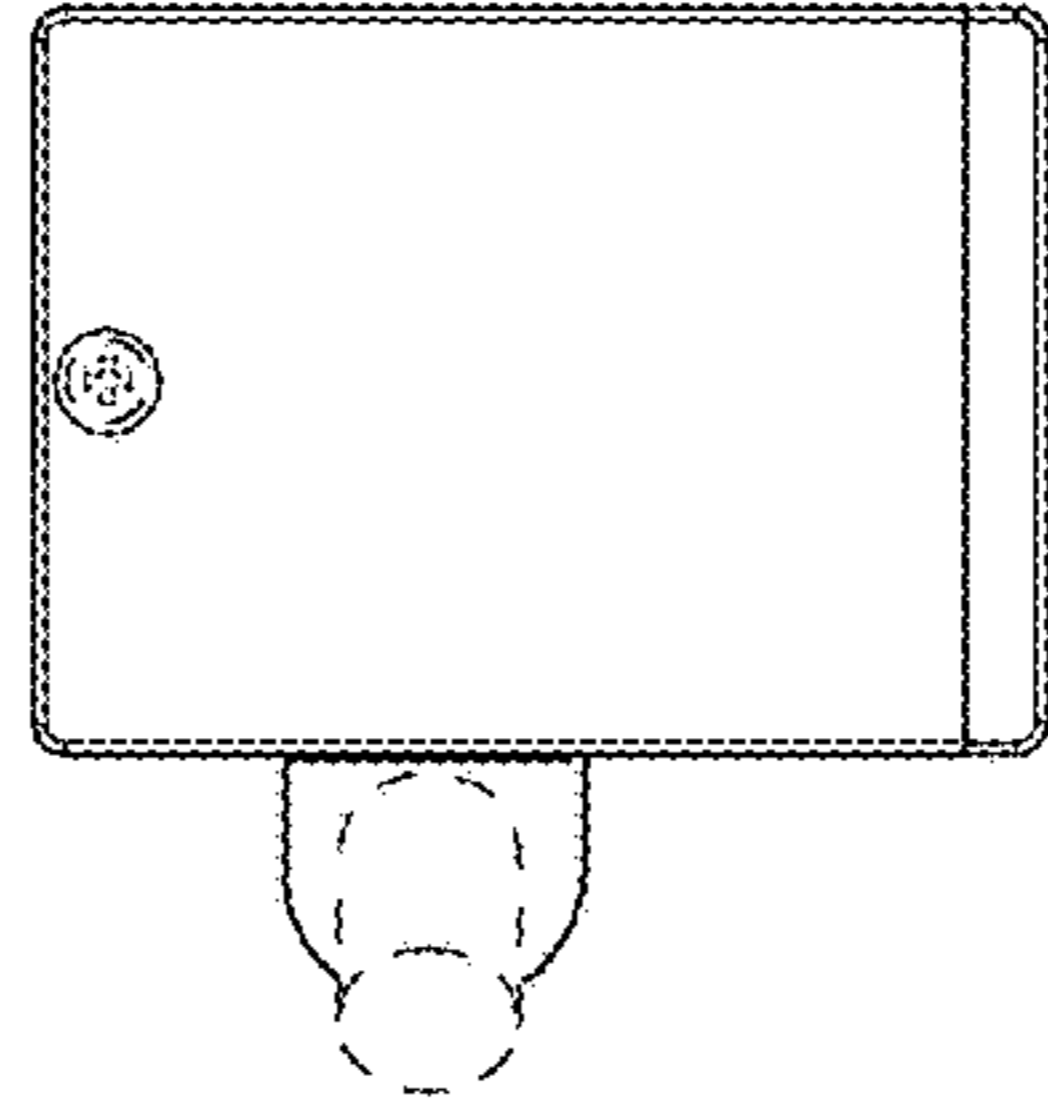

Fig. 23

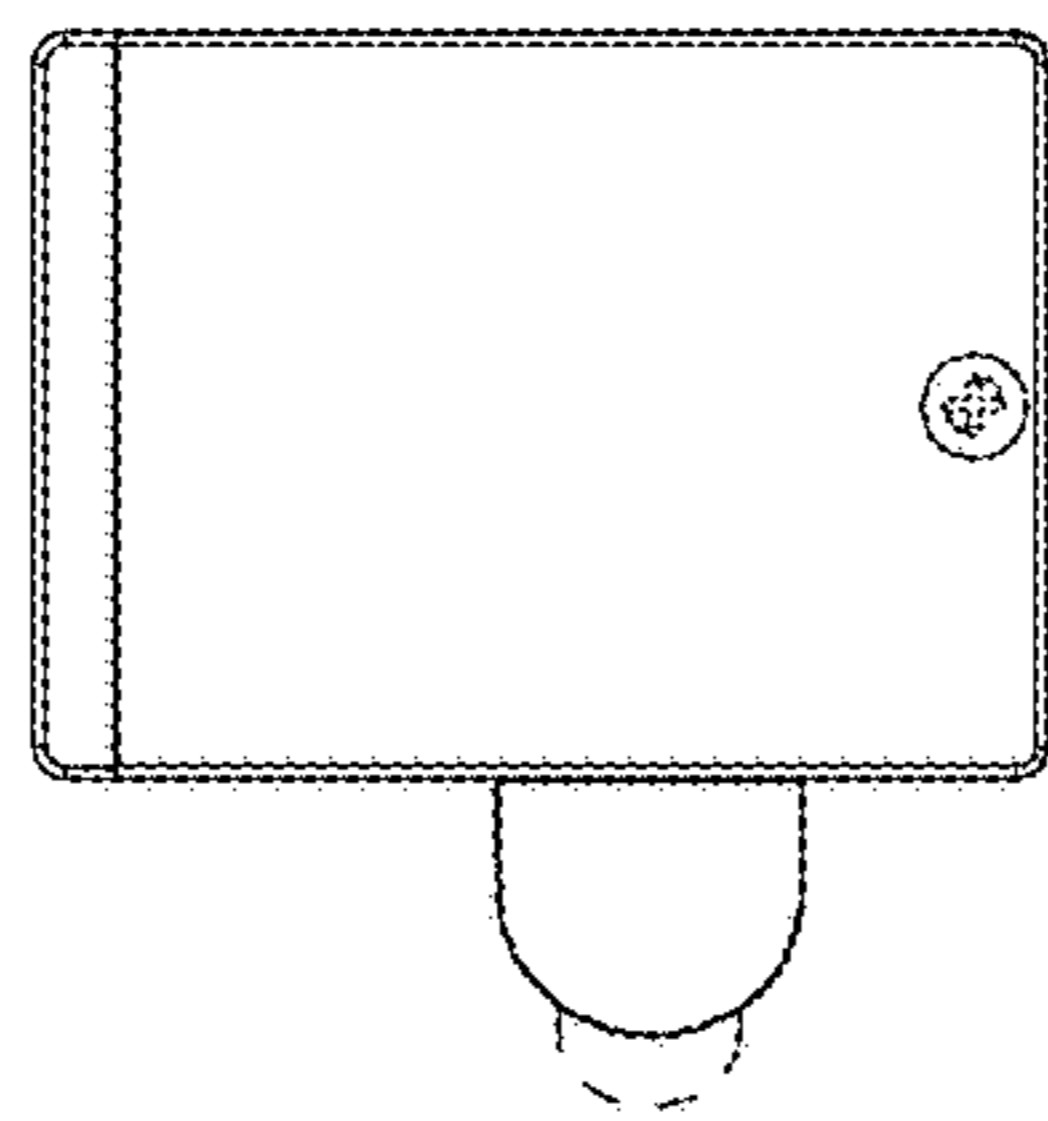

Fig. 24

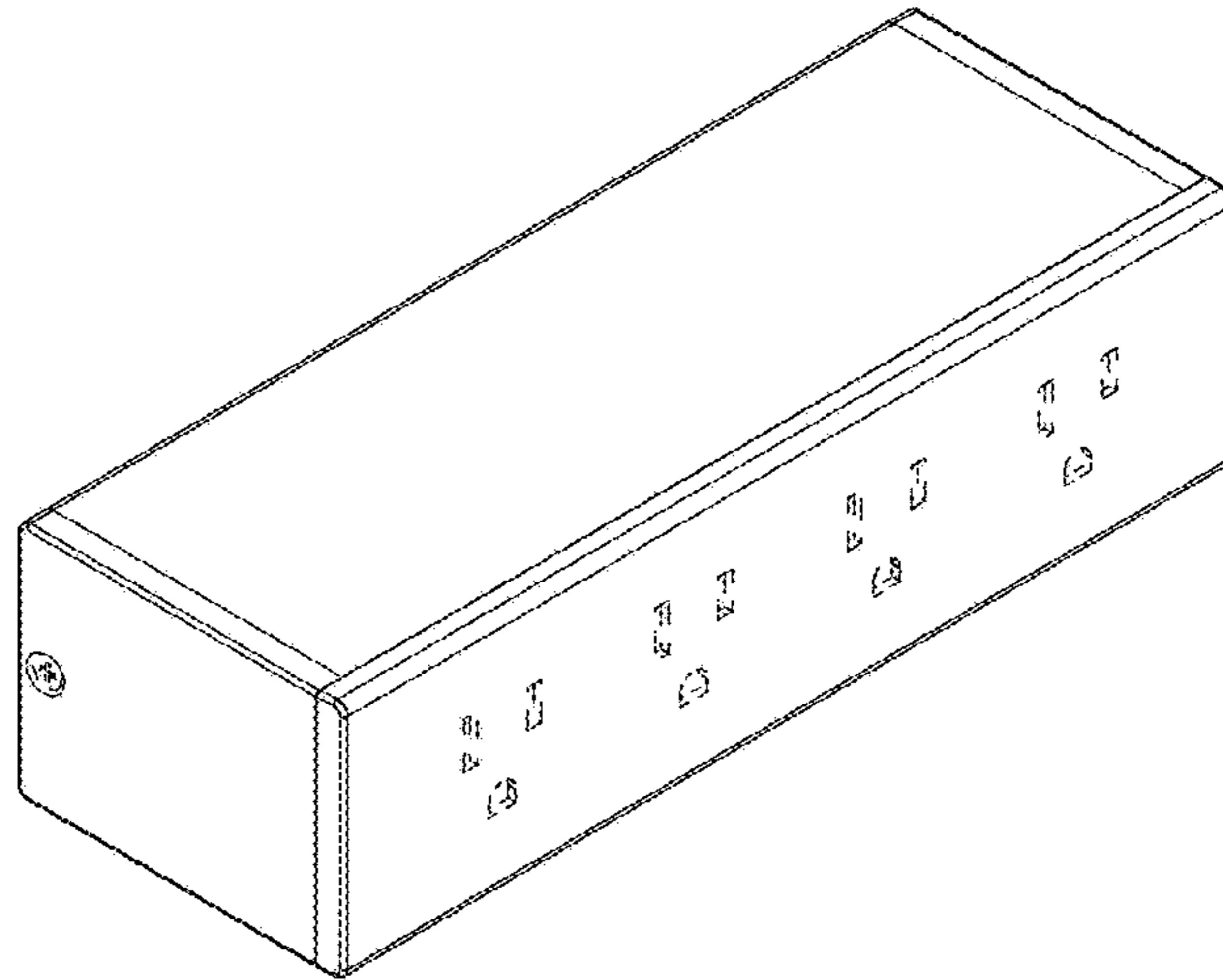

Fig. 25

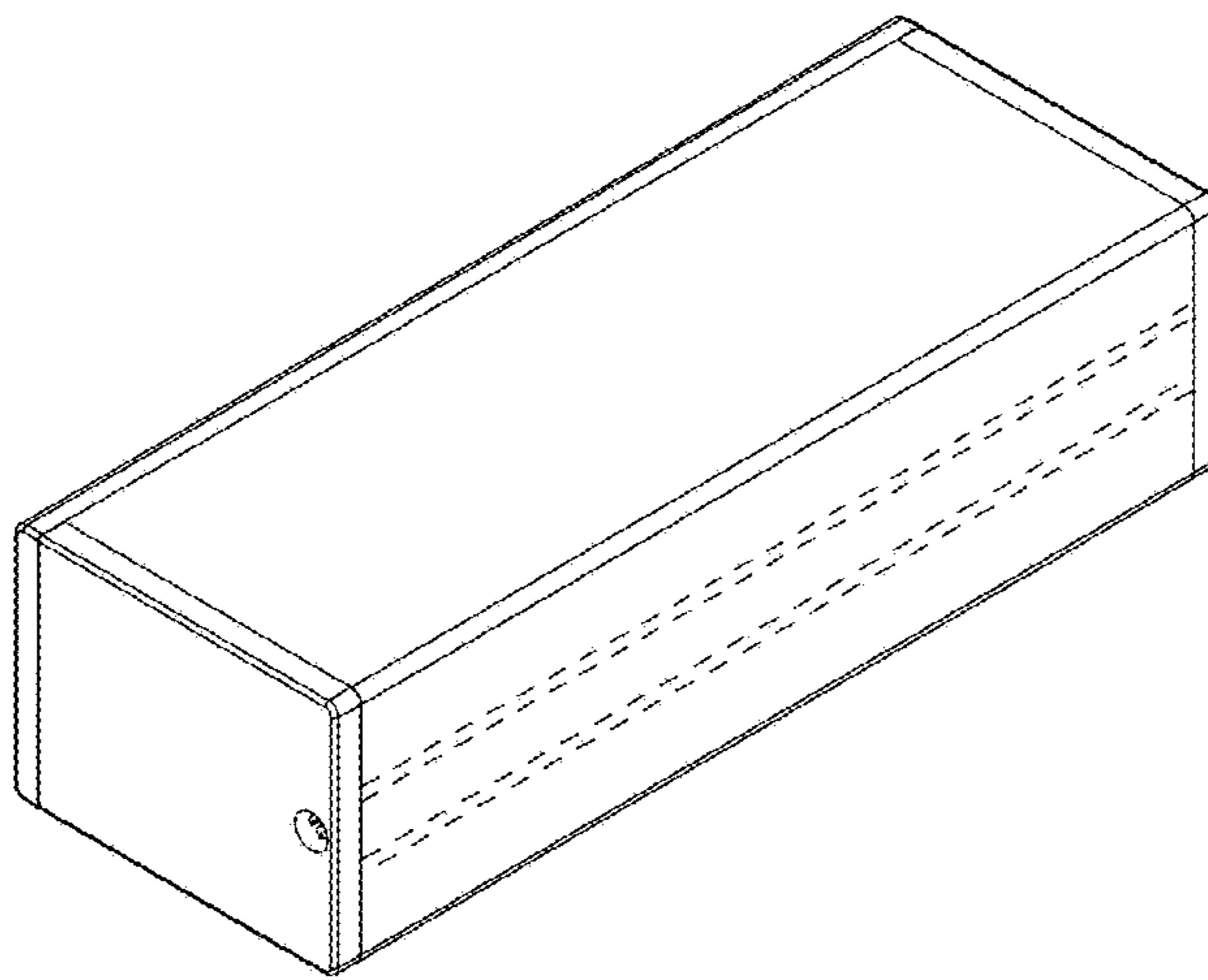

Fig. 26

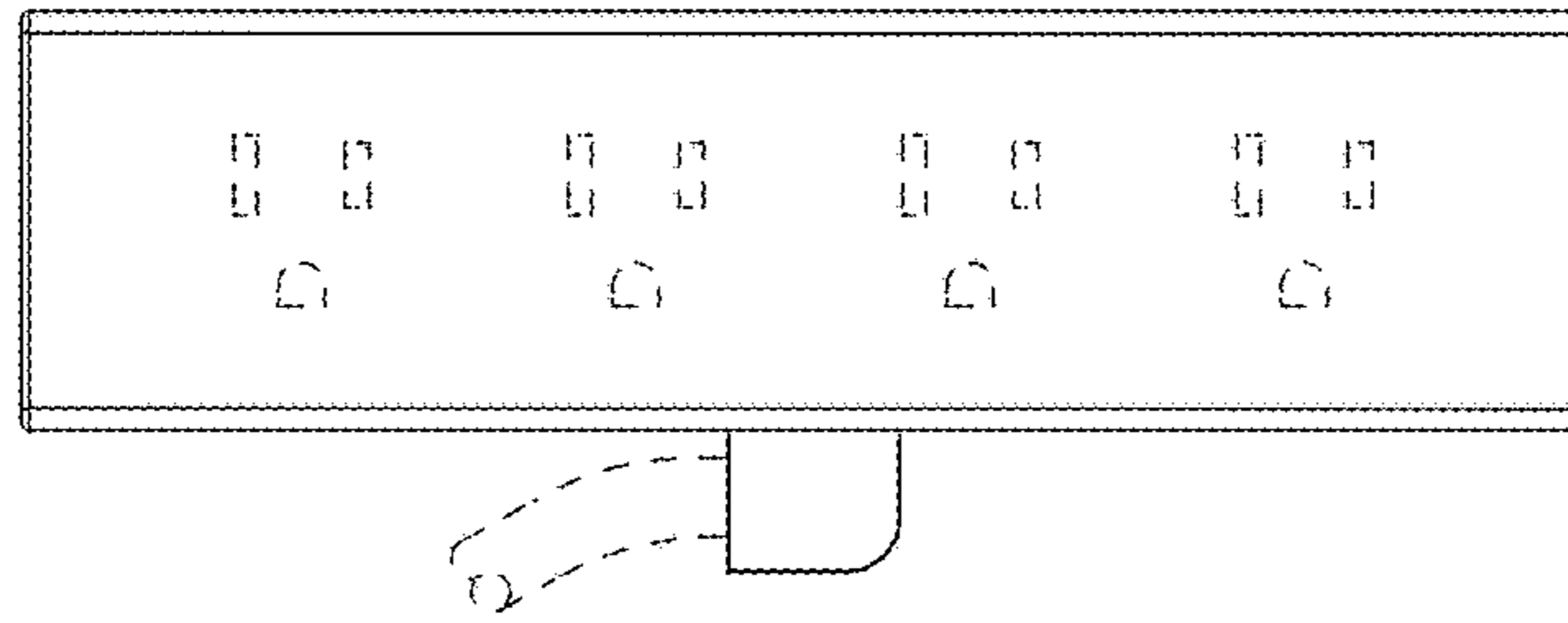

Fig. 27

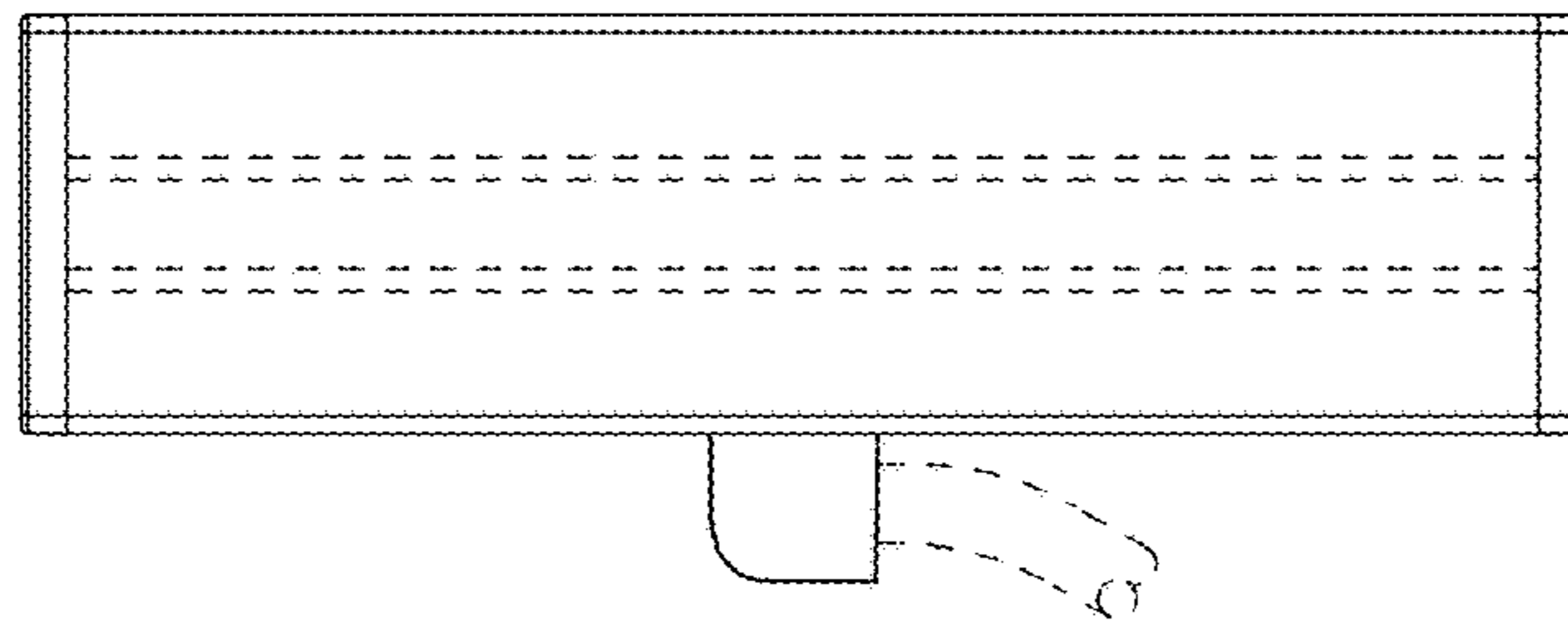

Fig. 28

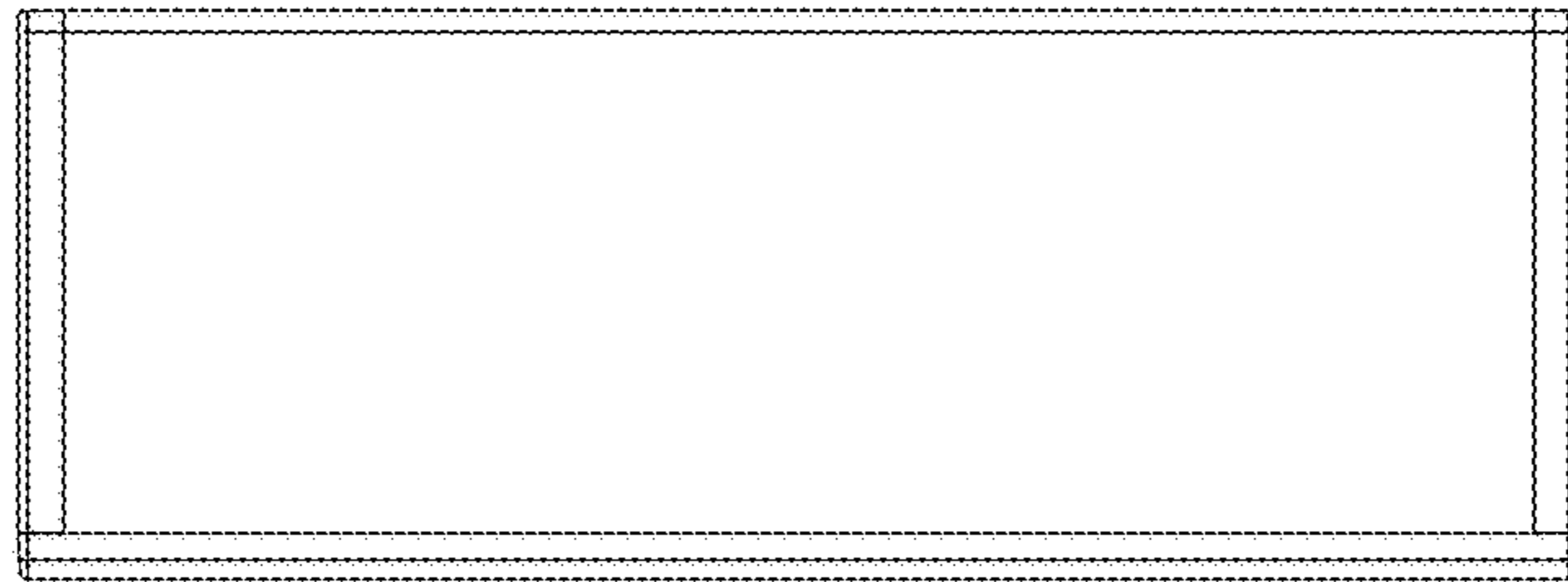

Fig. 29

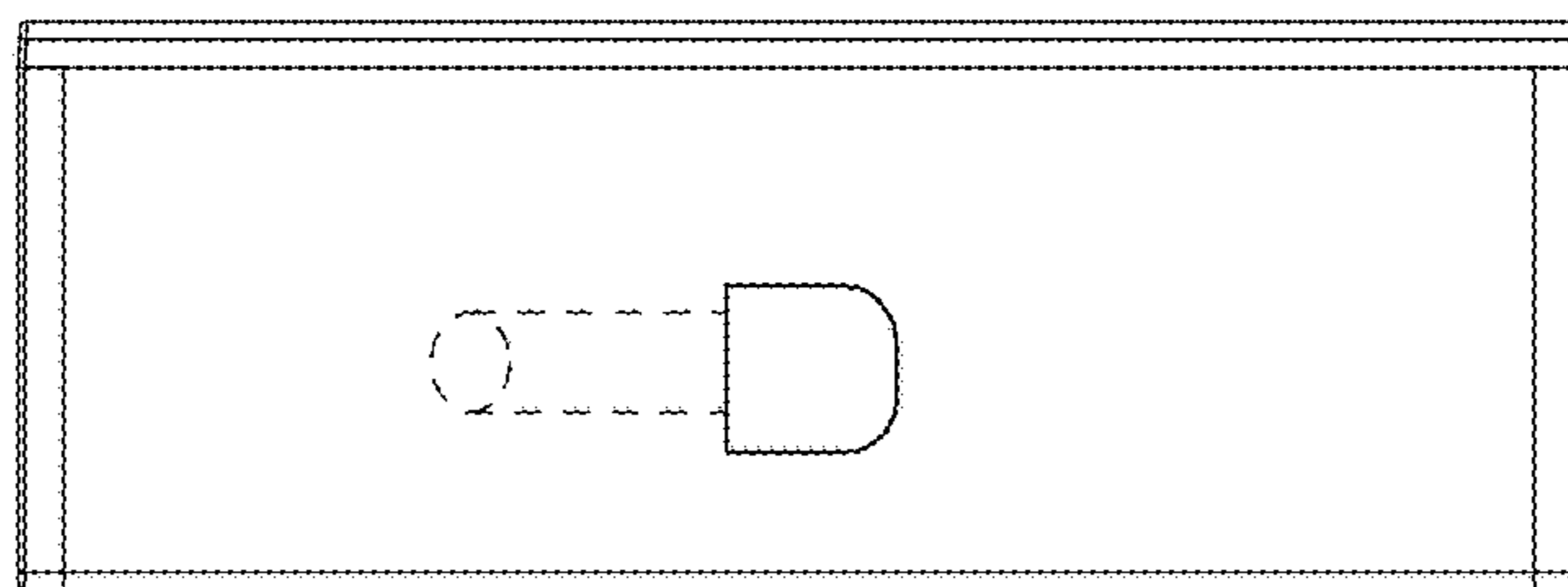

Fig. 30

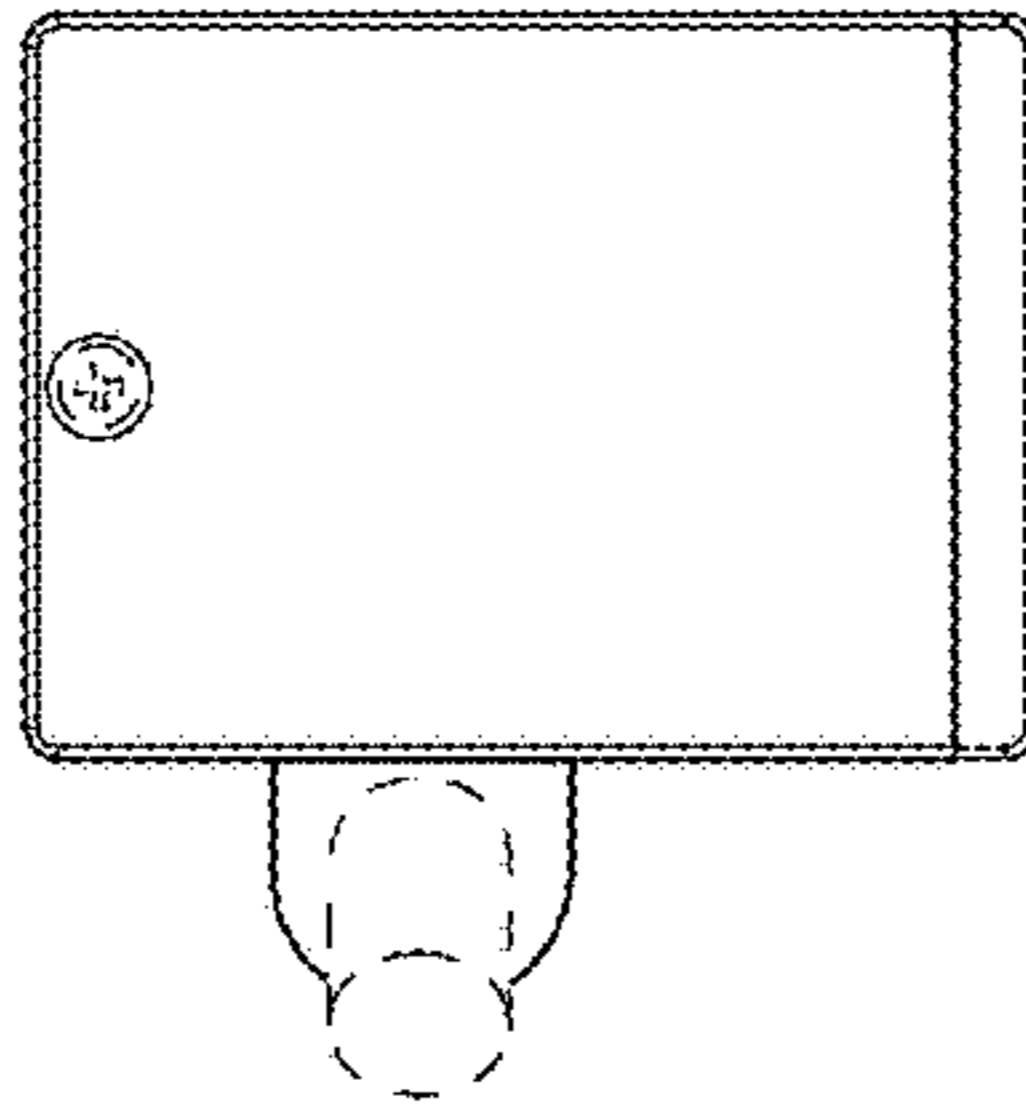

Fig. 31

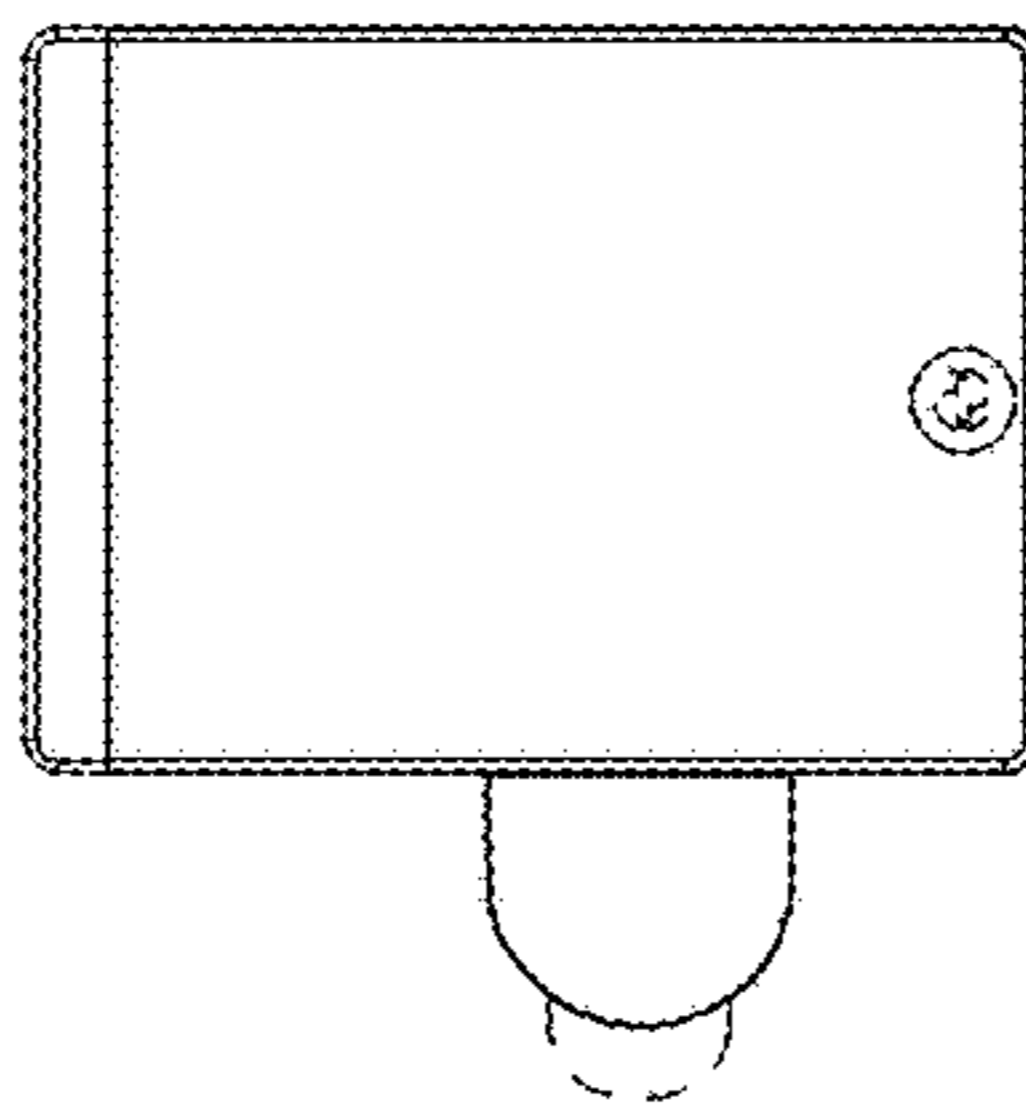

Fig. 32

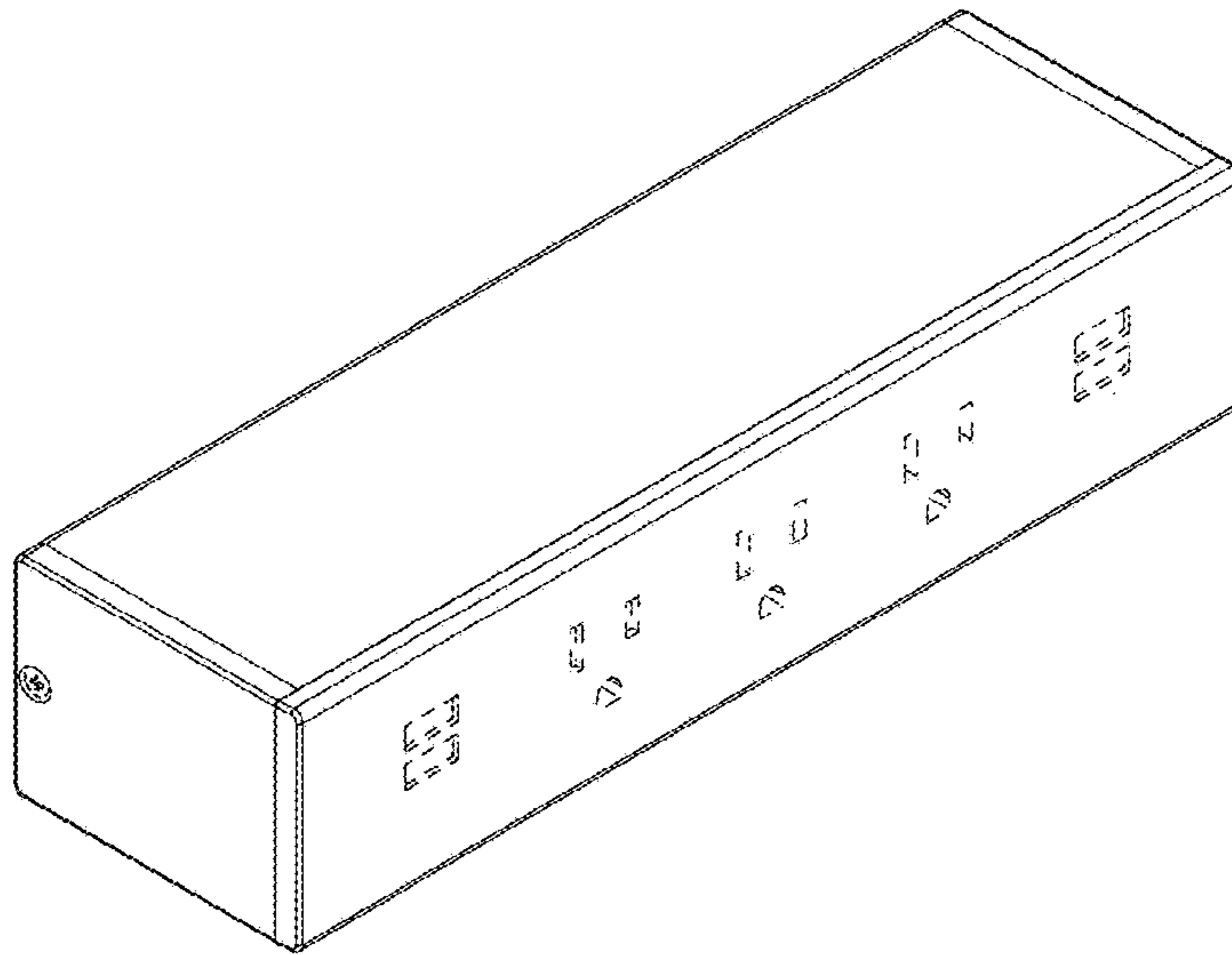

Fig. 33

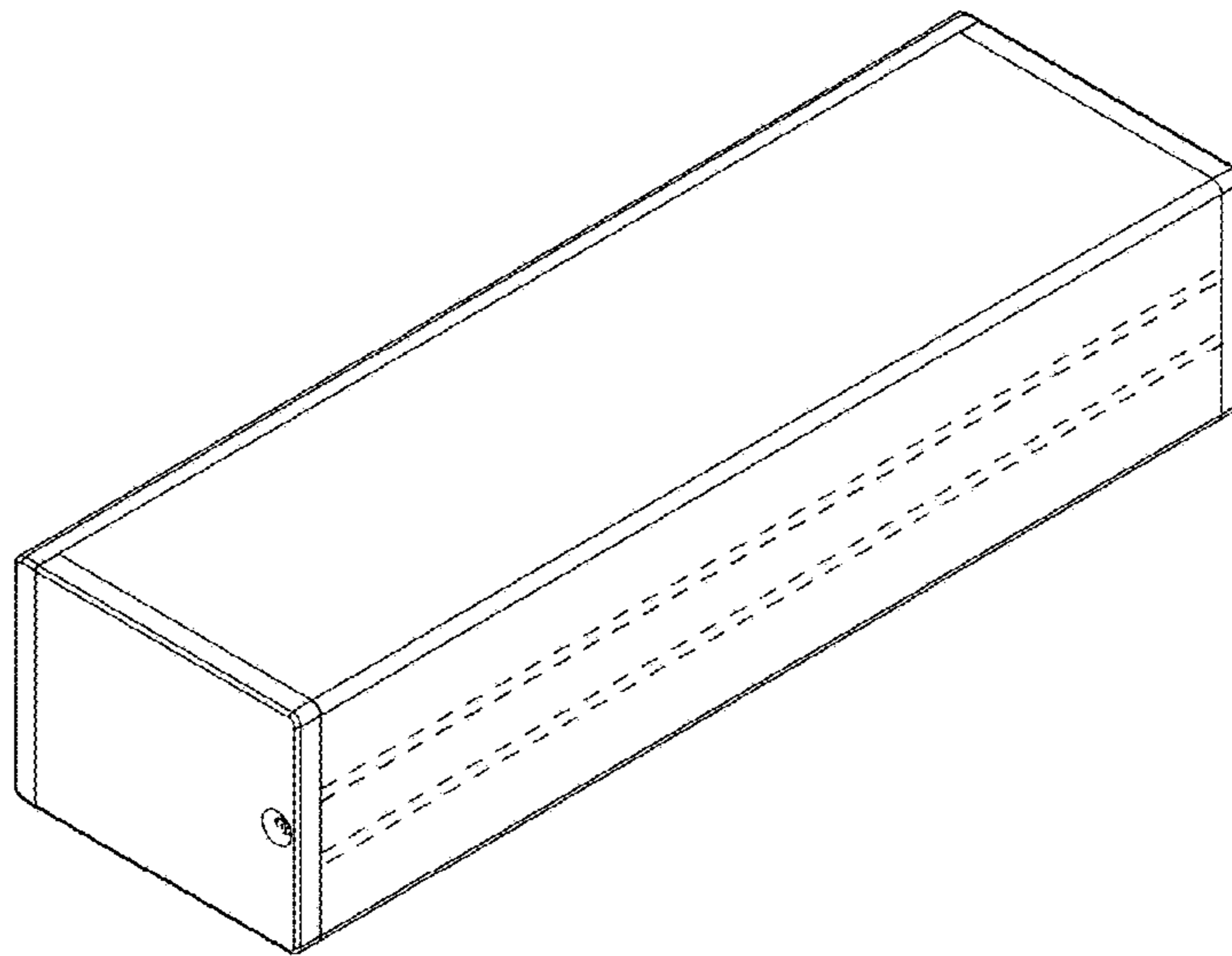

Fig. 34

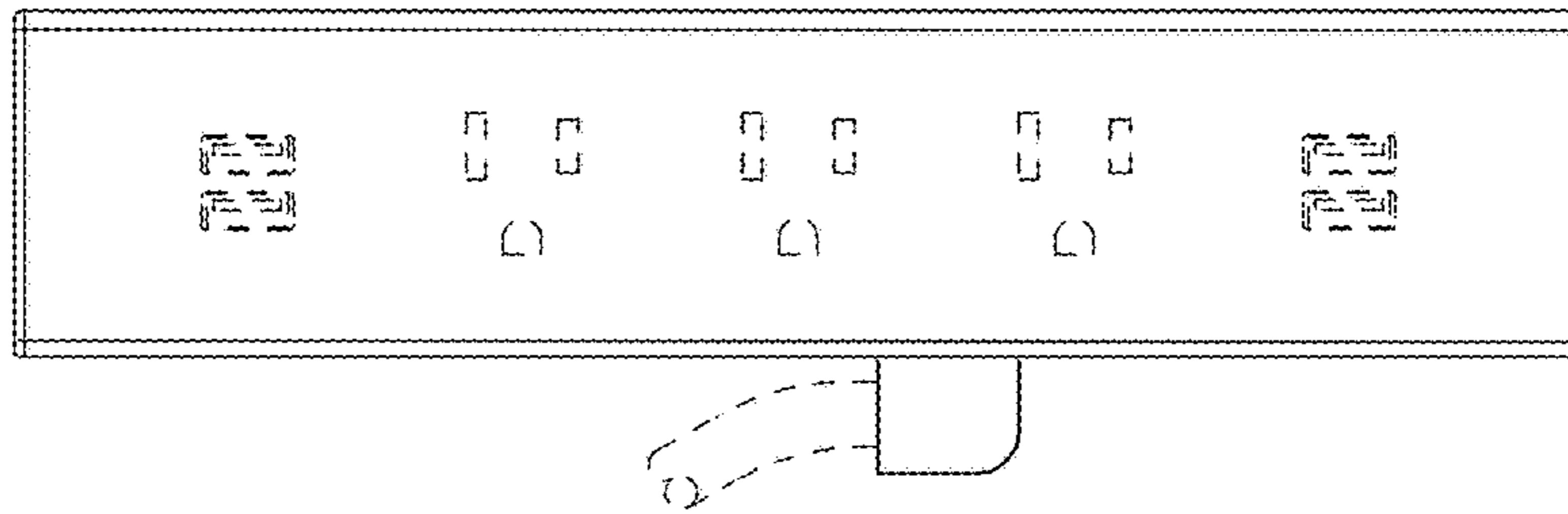

Fig. 35

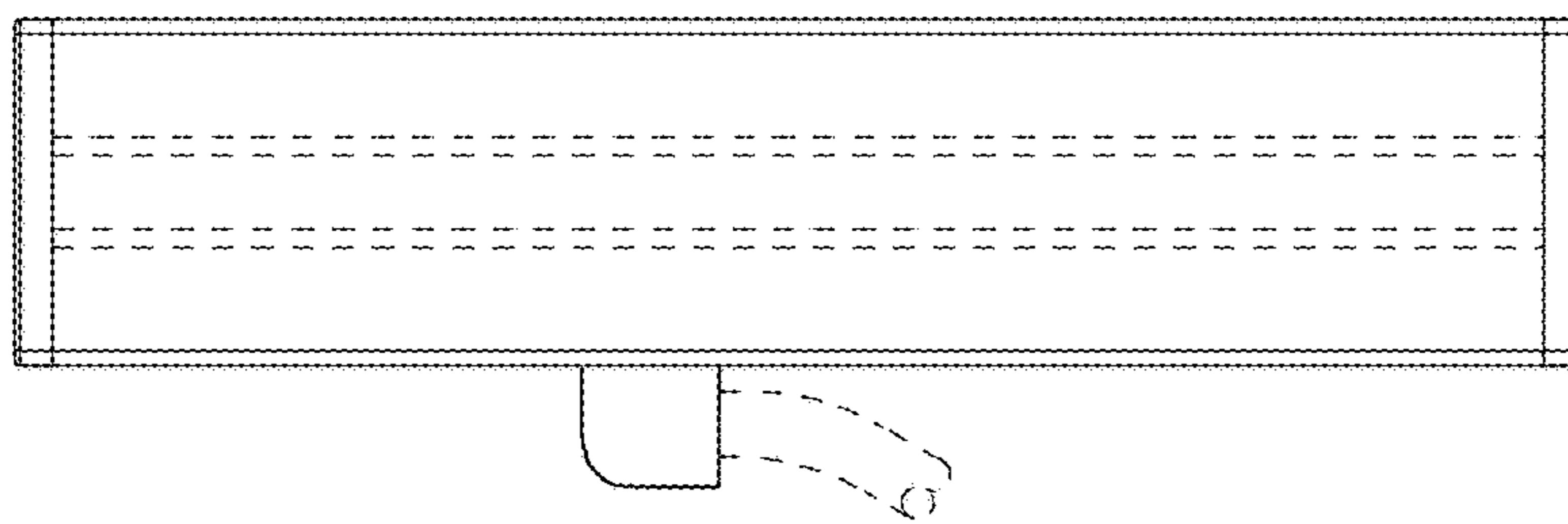

Fig. 36

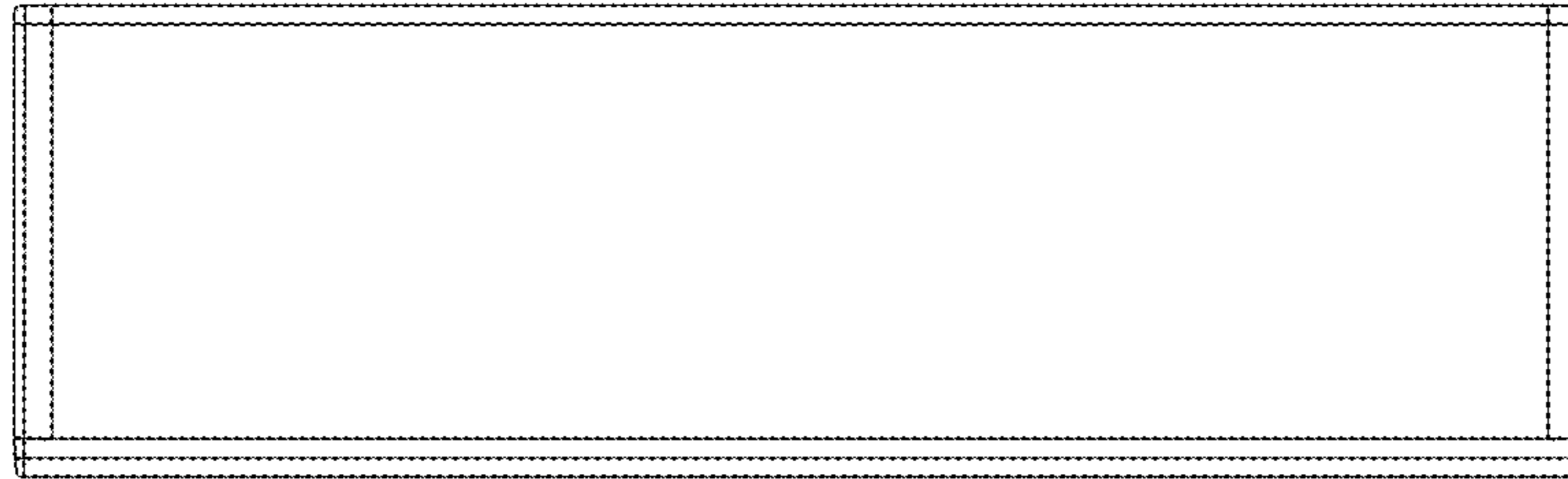

Fig. 37

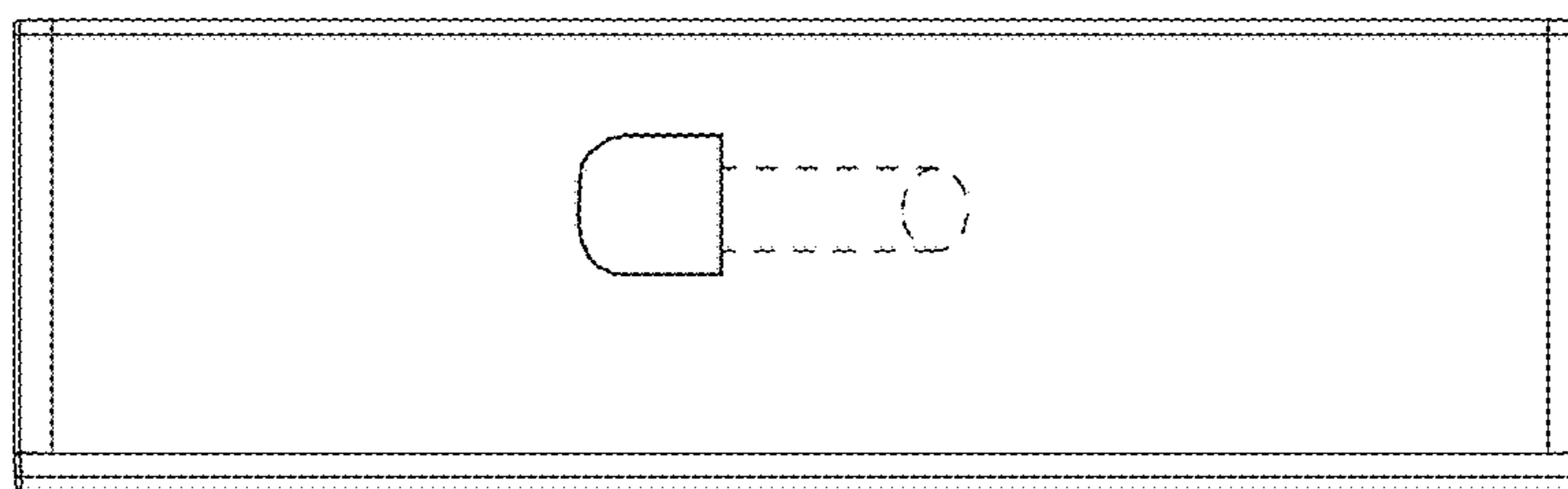

Fig. 38

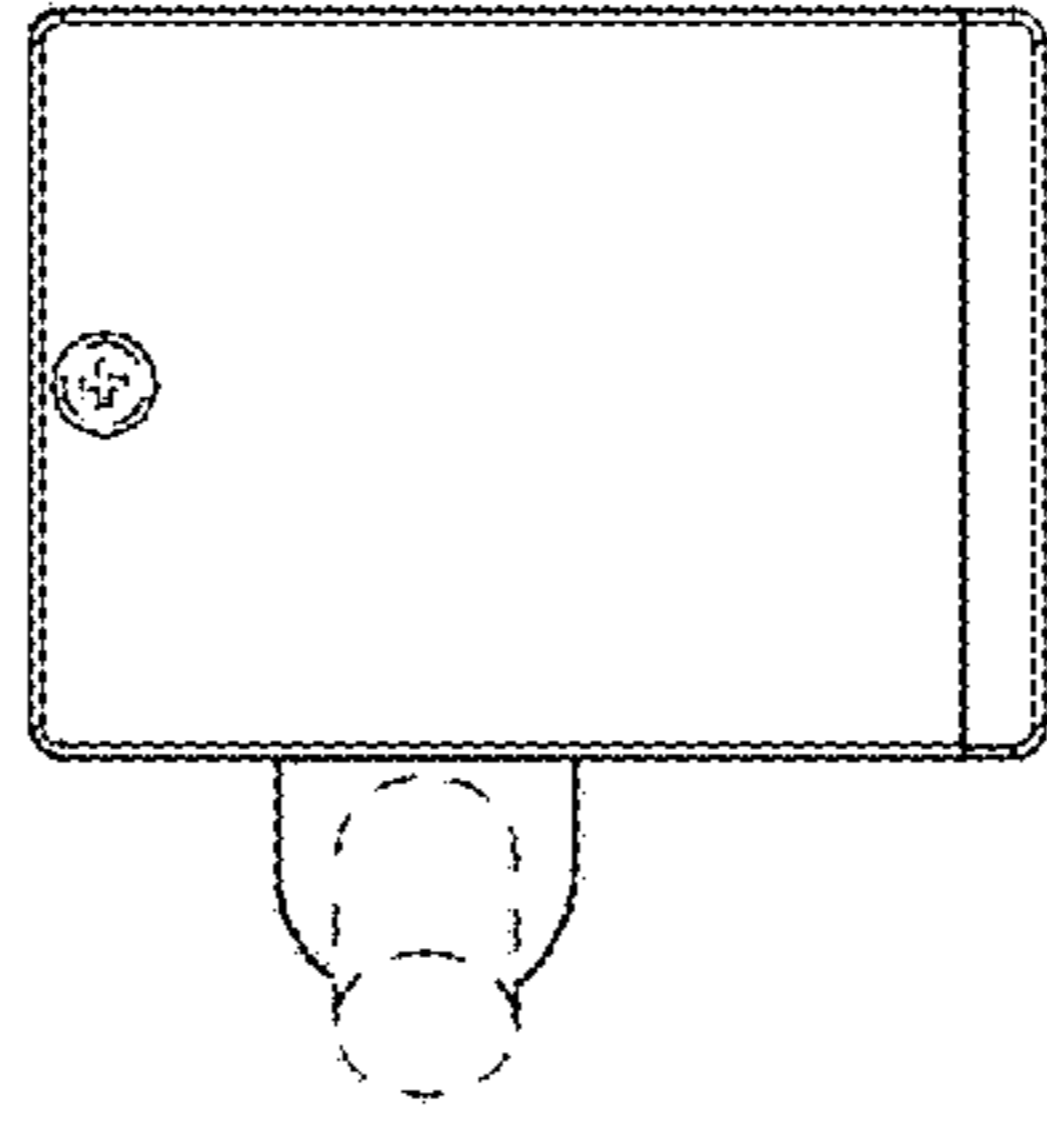

Fig. 39

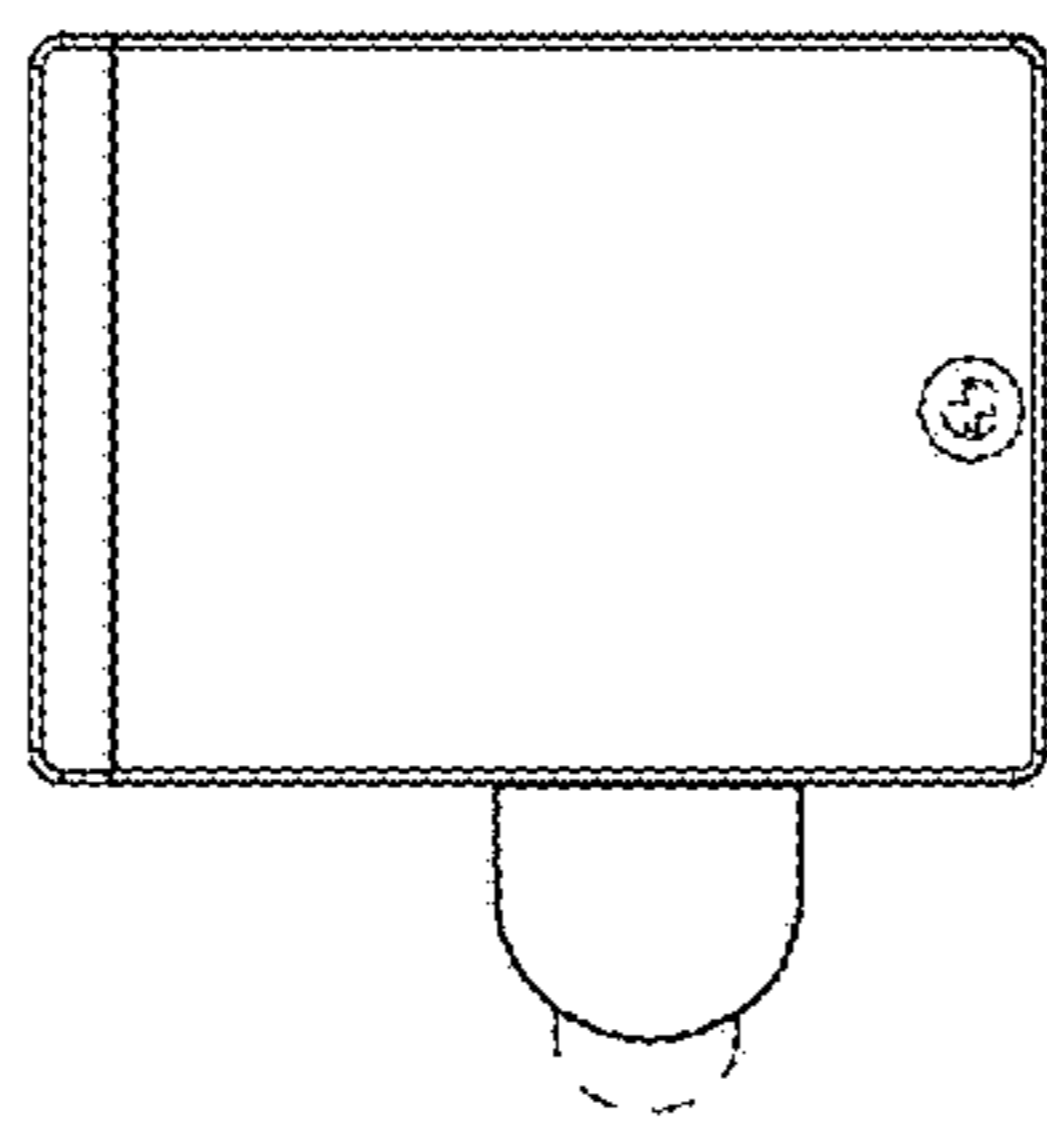

Fig. 40

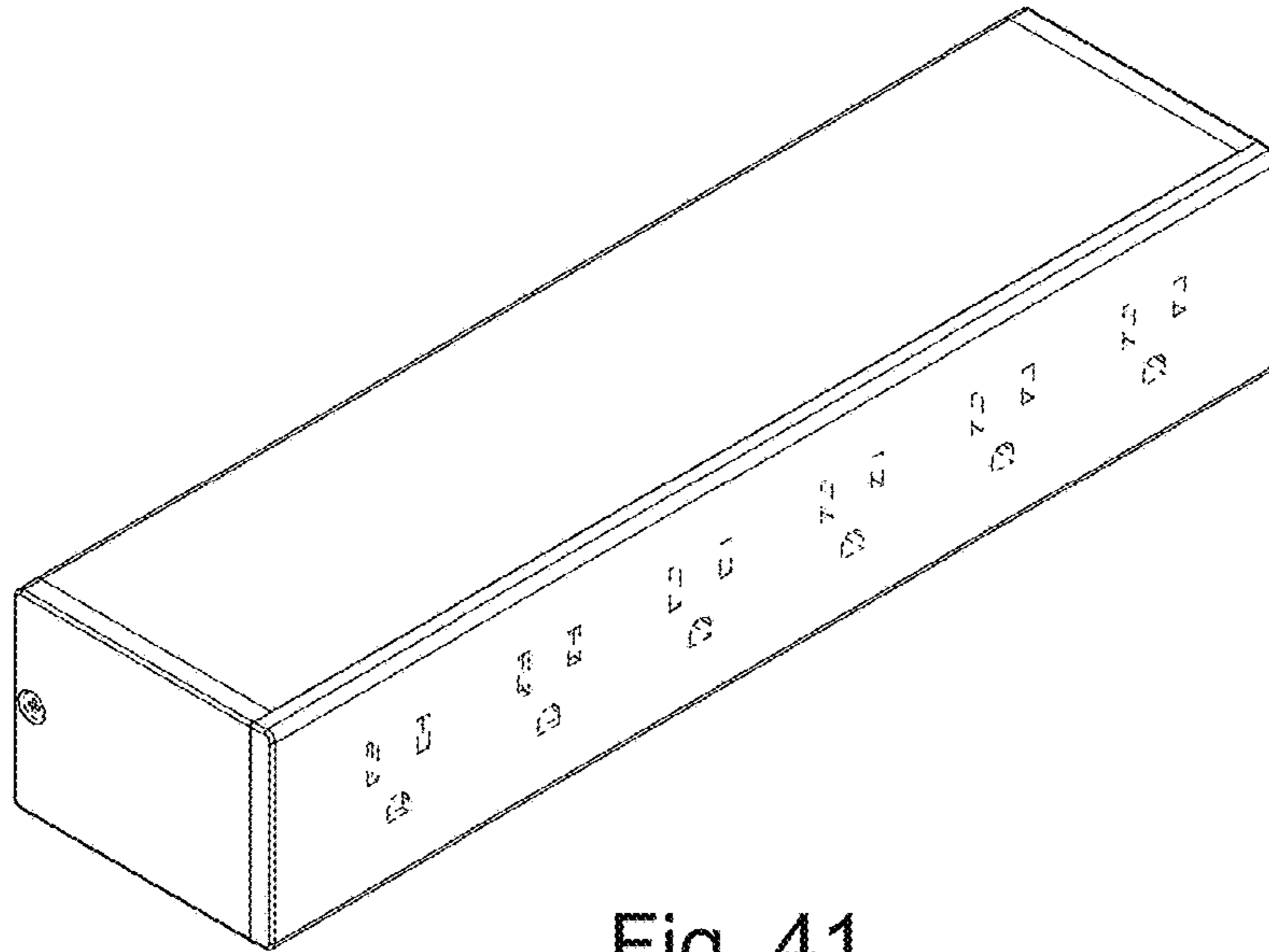

Fig. 41

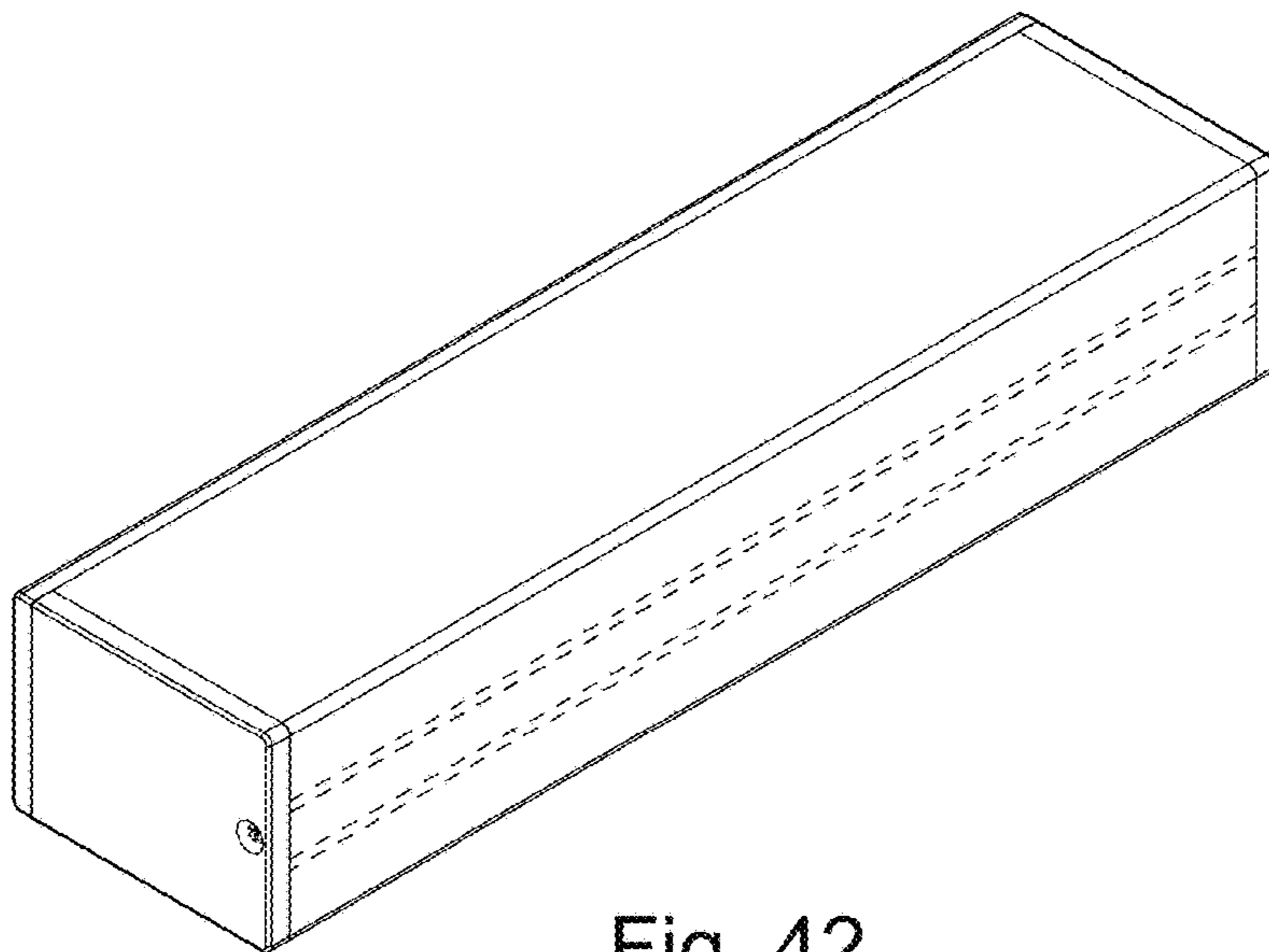

Fig. 42

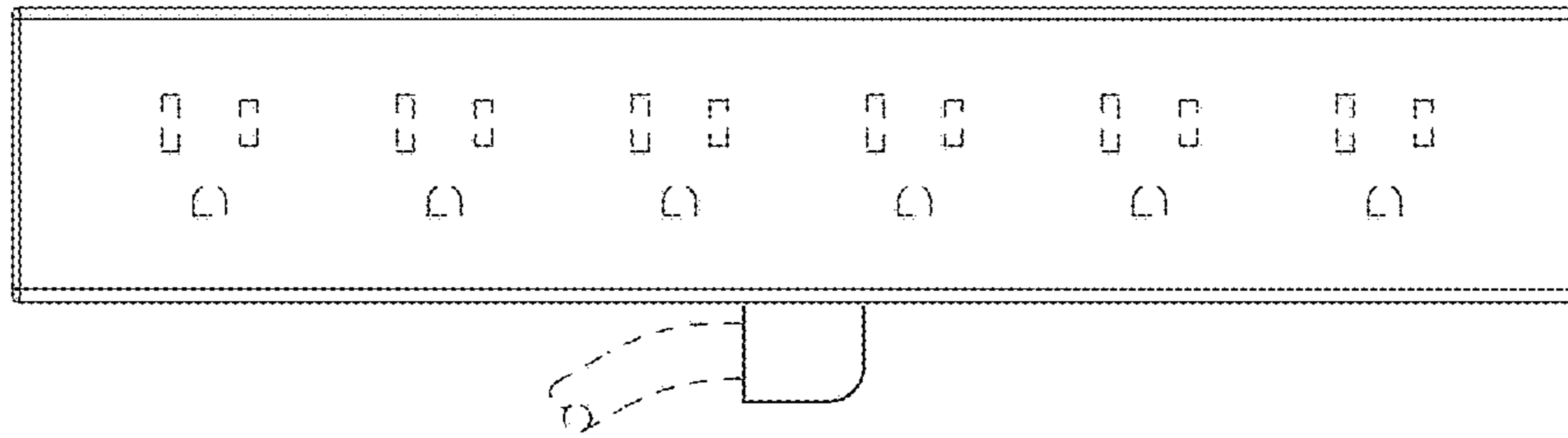

Fig. 43

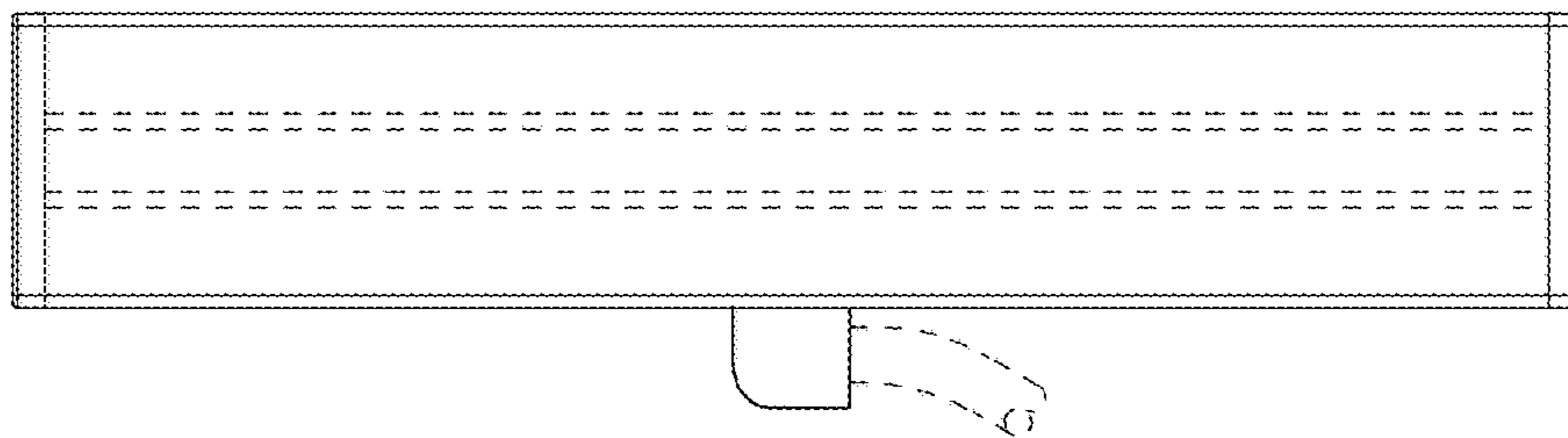

Fig. 44

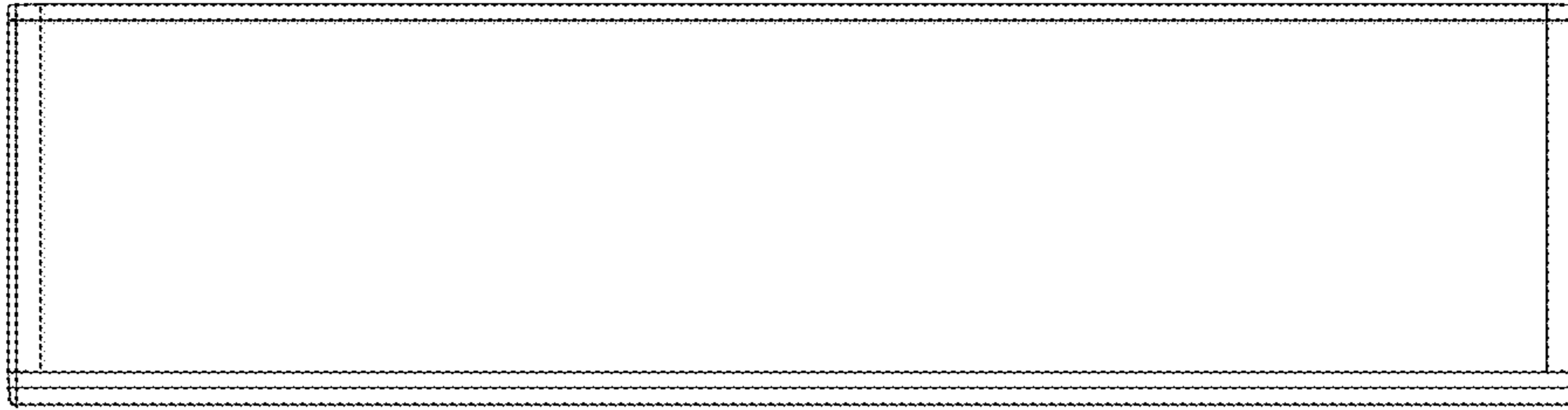

Fig. 45

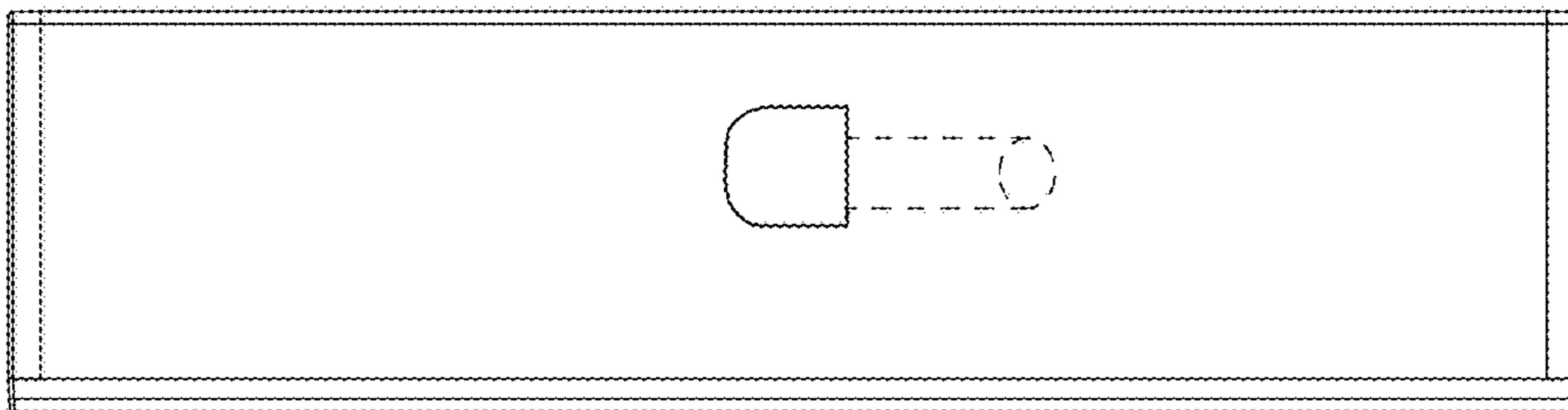

Fig. 46

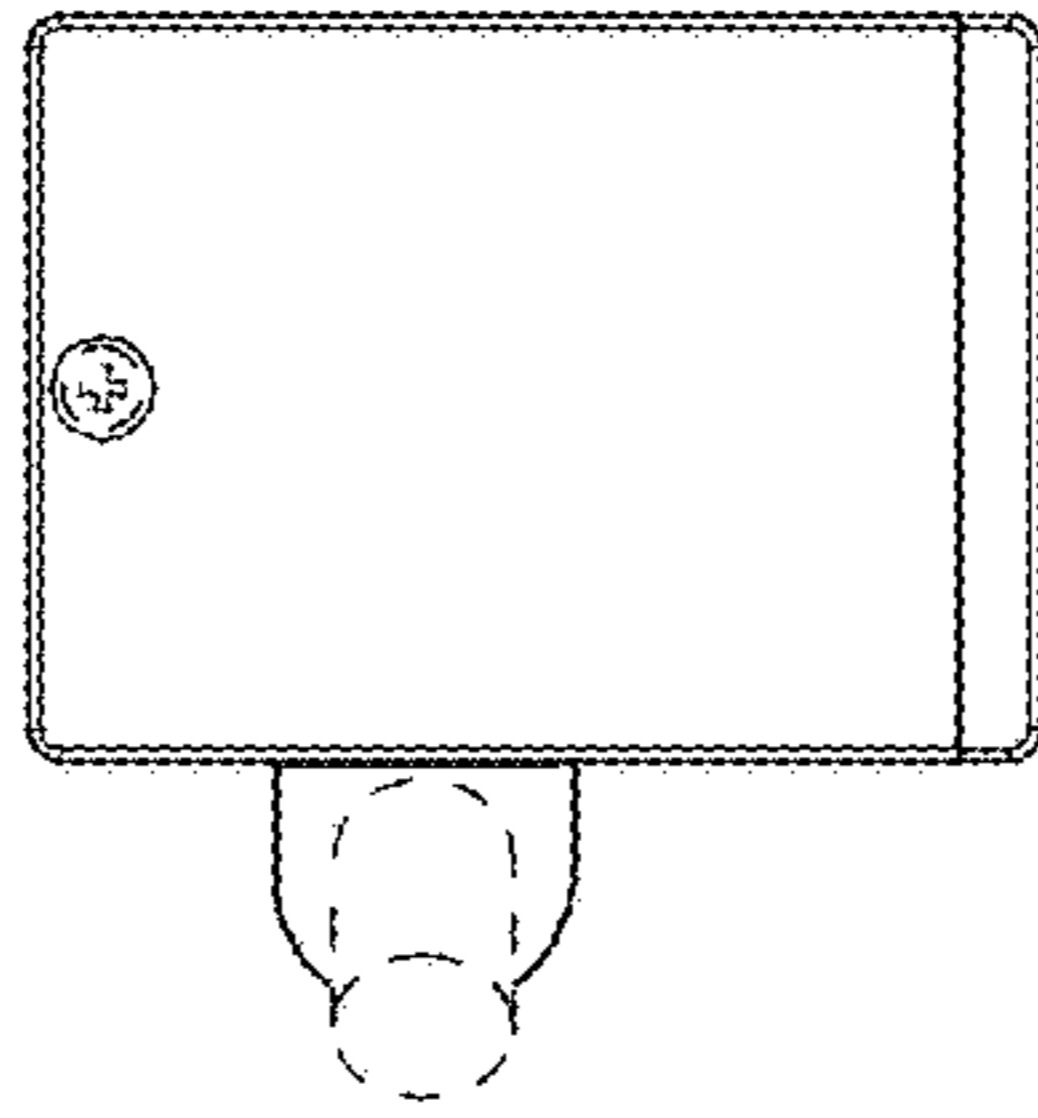

Fig. 47

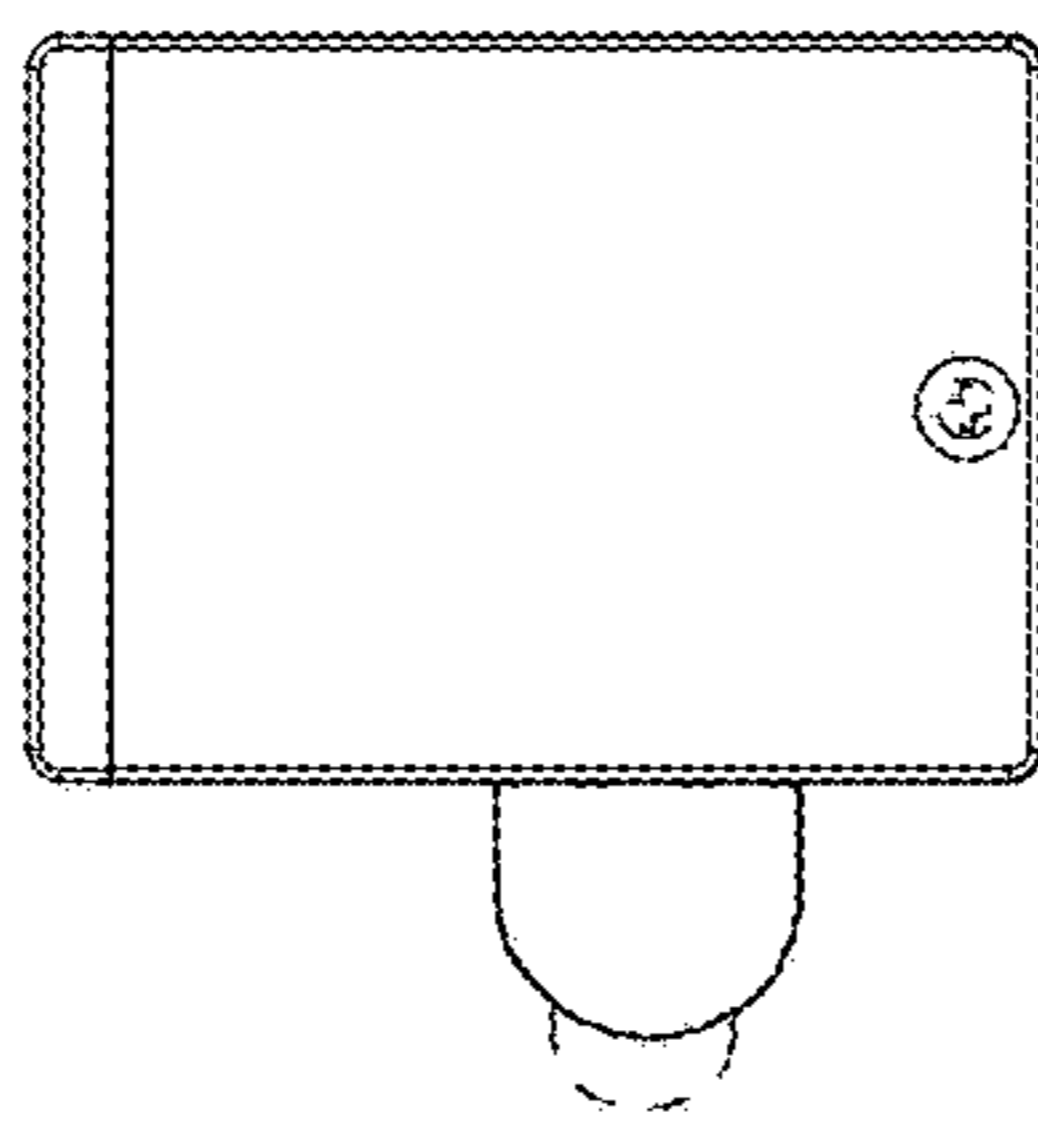

Fig. 48