



US00D849649S

(12) **United States Design Patent**
Grewer

(10) **Patent No.:** **US D849,649 S**

(45) **Date of Patent:** **** May 28, 2019**

(54) **WHEEL**

(71) Applicant: **Jaguar Land Rover Limited**, Whitley,
Coventry (GB)

(72) Inventor: **Dale Grewer**, Coventry (GB)

(73) Assignee: **Jaguar Land Rover Limited**, Whitley,
Coventry (GB)

(**) Term: **15 Years**

(21) Appl. No.: **29/638,020**

(22) Filed: **Feb. 23, 2018**

(30) **Foreign Application Priority Data**

Sep. 6, 2017 (EM) 004244275

(51) **LOC (11) Cl.** **12-16**

(52) **U.S. Cl.**
USPC **D12/209**

(58) **Field of Classification Search**
USPC D12/204–213
CPC B60B 7/00; B60B 7/02; B60B 7/04; B60B
7/01; B60B 7/06; B60B 3/04; B60B 1/00;
B60B 3/10; B60B 1/10; B60B 1/08;
B60B 3/06; B60B 1/12; B60B 3/02
See application file for complete search history.

(56) **References Cited**

U.S. PATENT DOCUMENTS

D691,081 S * 10/2013 Watkin D12/211
D697,467 S * 1/2014 Pollmann D12/209

D725,568 S * 3/2015 Hodges D12/209
D725,569 S * 3/2015 Komukai D12/209
D738,278 S * 9/2015 Wolff D12/209
D756,878 S * 5/2016 Valencia Pollex D12/209
D774,437 S * 12/2016 Nakano D12/209
D782,384 S * 3/2017 Oh D12/209
D788,003 S * 5/2017 Conforzi D12/209
D788,674 S * 6/2017 Mielke D12/209
D794,530 S * 8/2017 Langhals D12/211
D823,224 S * 7/2018 Nakamura D12/211
D823,432 S * 7/2018 Oh D23/209
D826,826 S * 8/2018 Back D12/209
D828,266 S * 9/2018 Garcia D12/209
D828,269 S * 9/2018 Kikuchi D12/209
D830,941 S * 10/2018 Hamilton D12/211
D835,561 S * 12/2018 Hayashi D12/209

* cited by examiner

Primary Examiner — Stacia A Cadmus

(74) *Attorney, Agent, or Firm* — Wood Herron & Evans
LLP

(57) **CLAIM**

The ornamental design for a wheel, as shown and described.

DESCRIPTION

FIG. 1 is a front left perspective view of a wheel for a vehicle according to the present invention.

FIG. 2 is a front view of the wheel shown in FIG. 1; and, FIG. 3 is a left side view thereof, the right side view being a mirror image thereof.

1 Claim, 3 Drawing Sheets

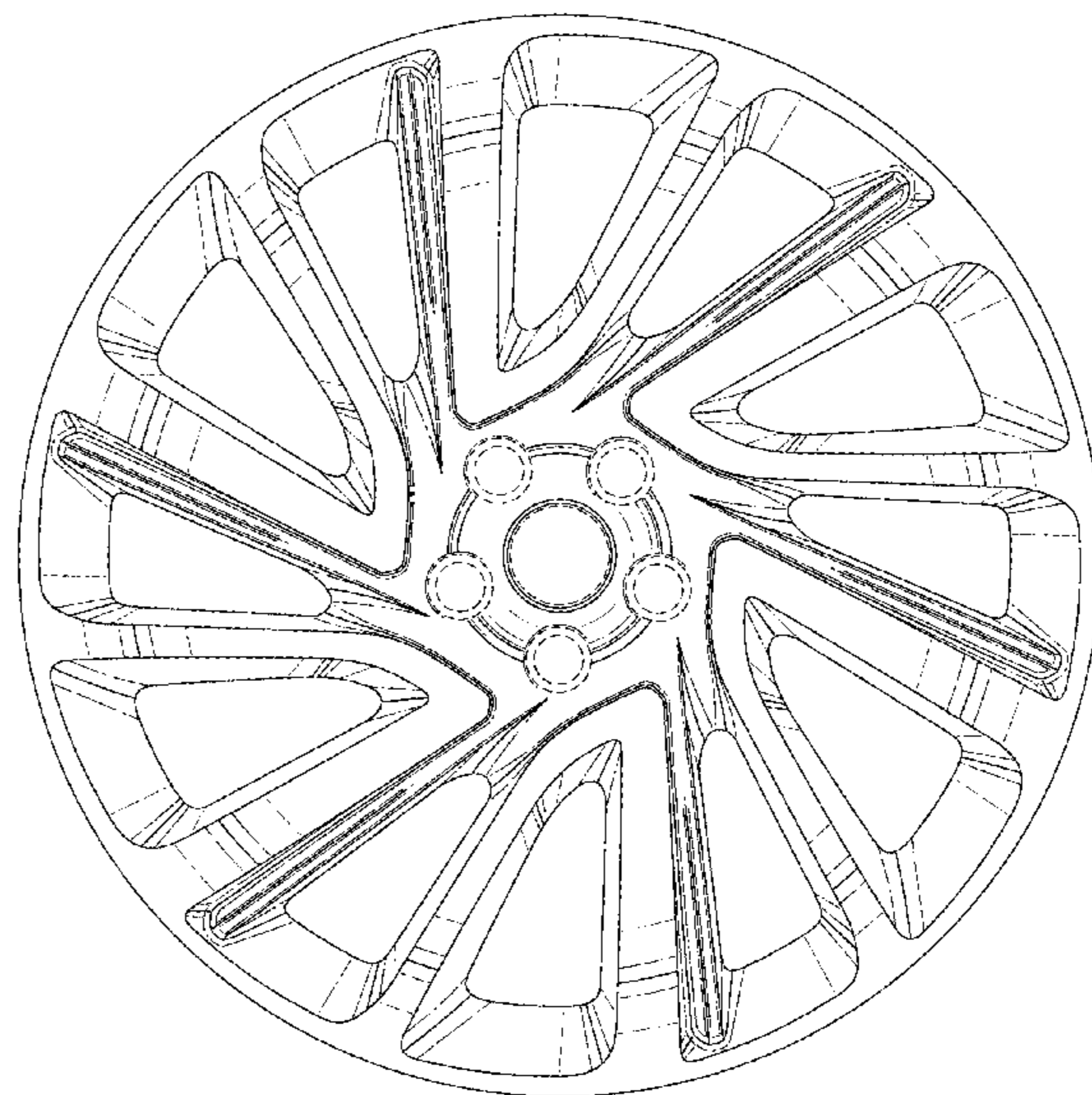
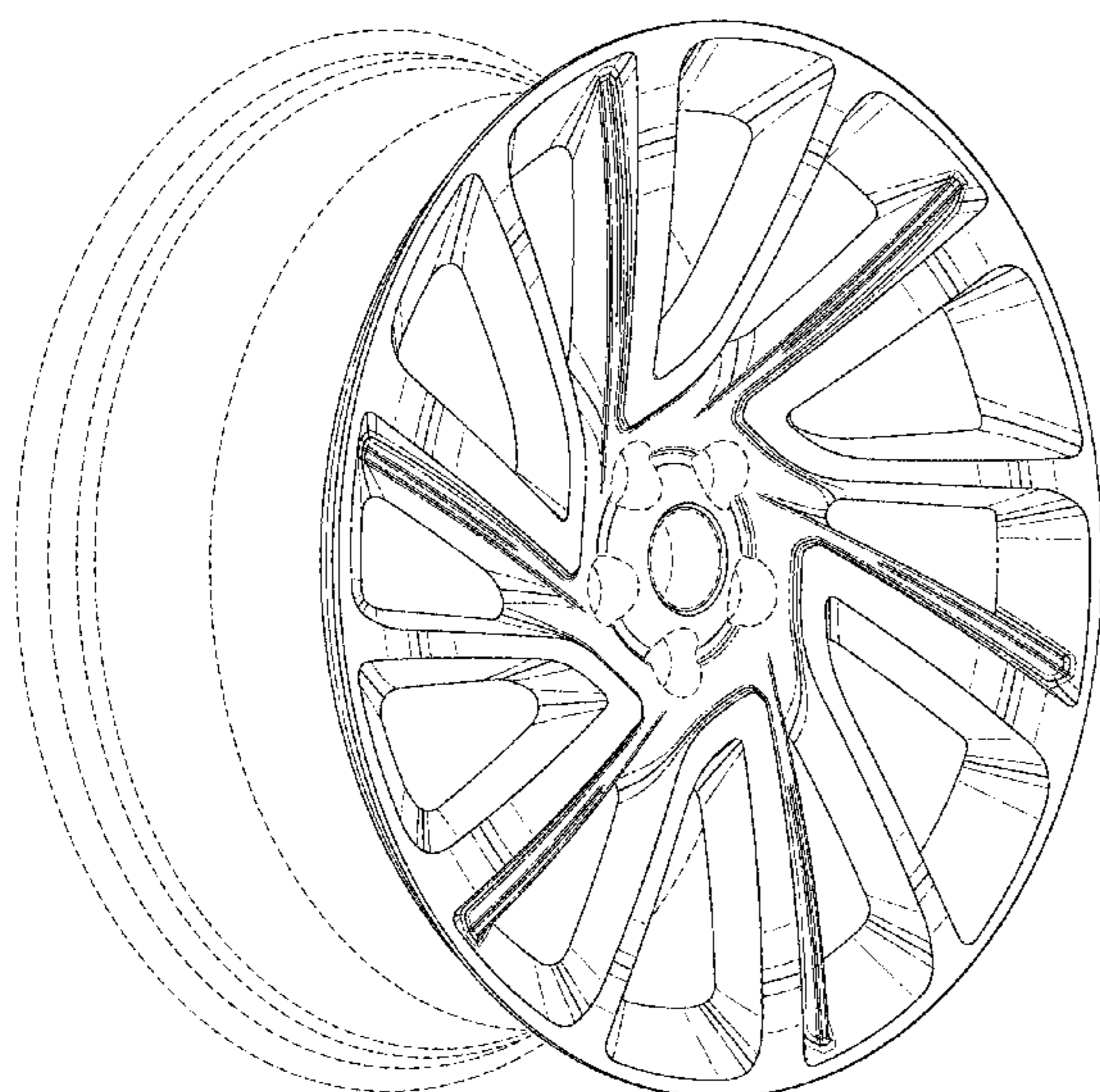

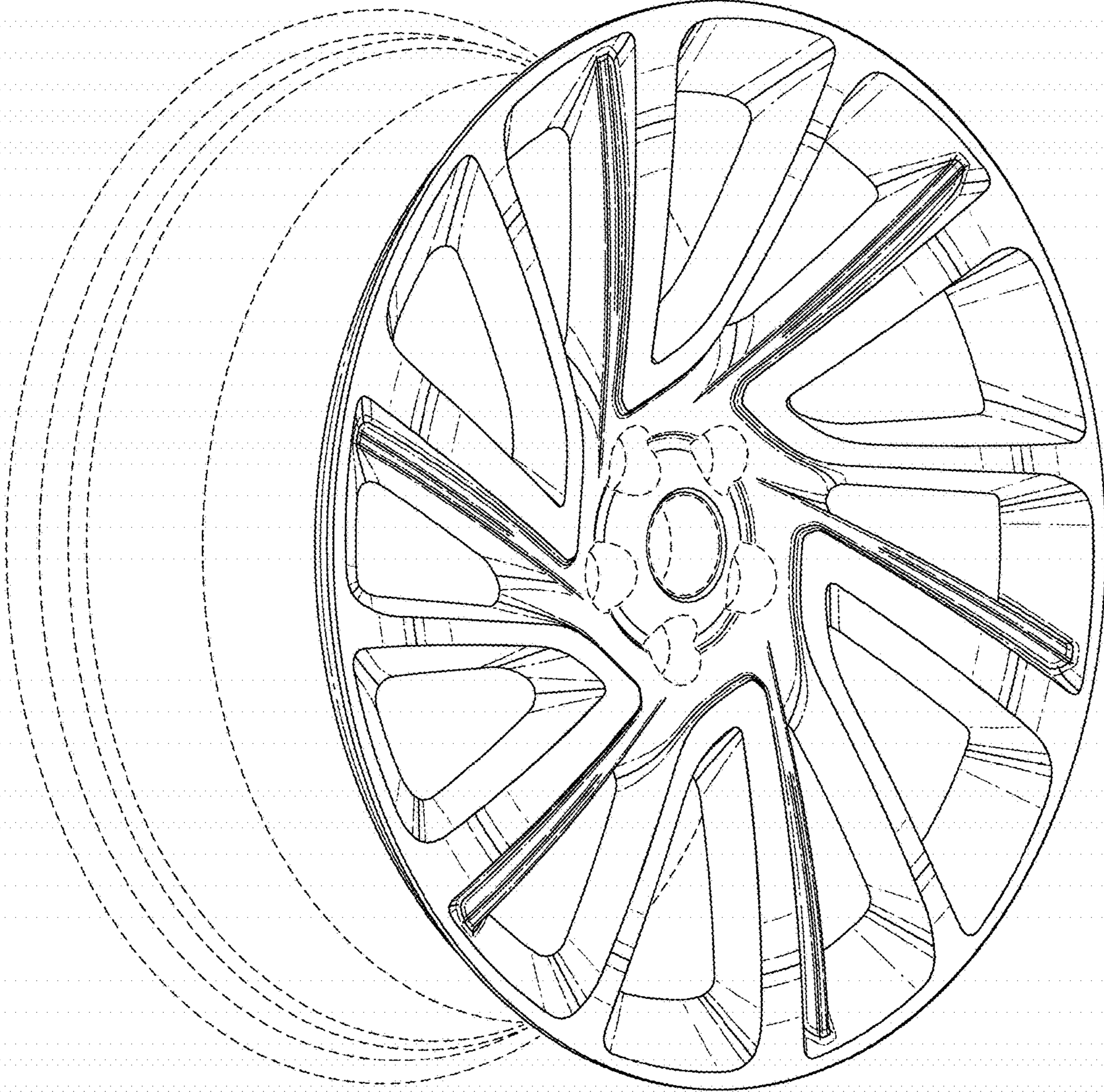

FIG. 1

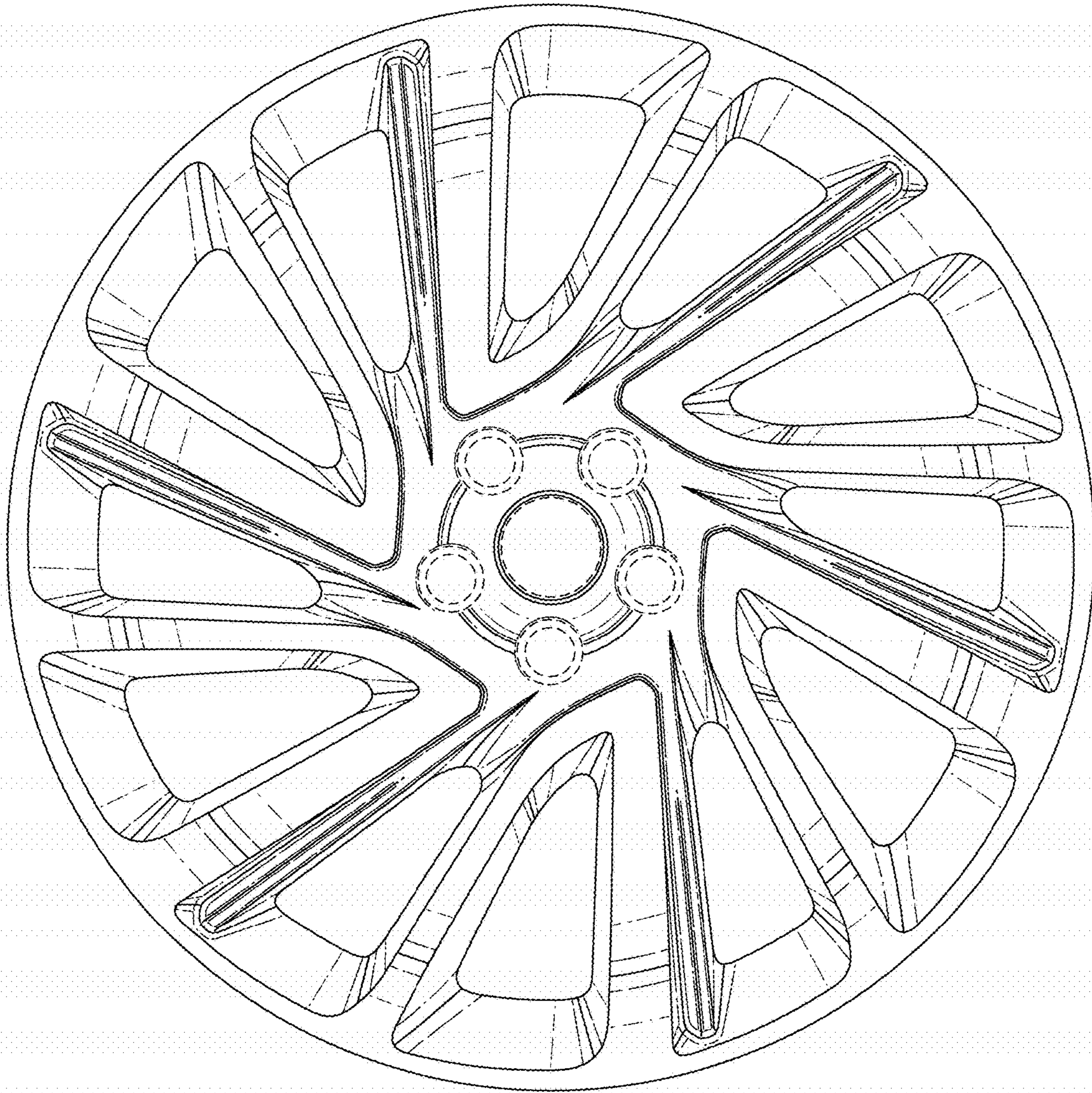

FIG. 2

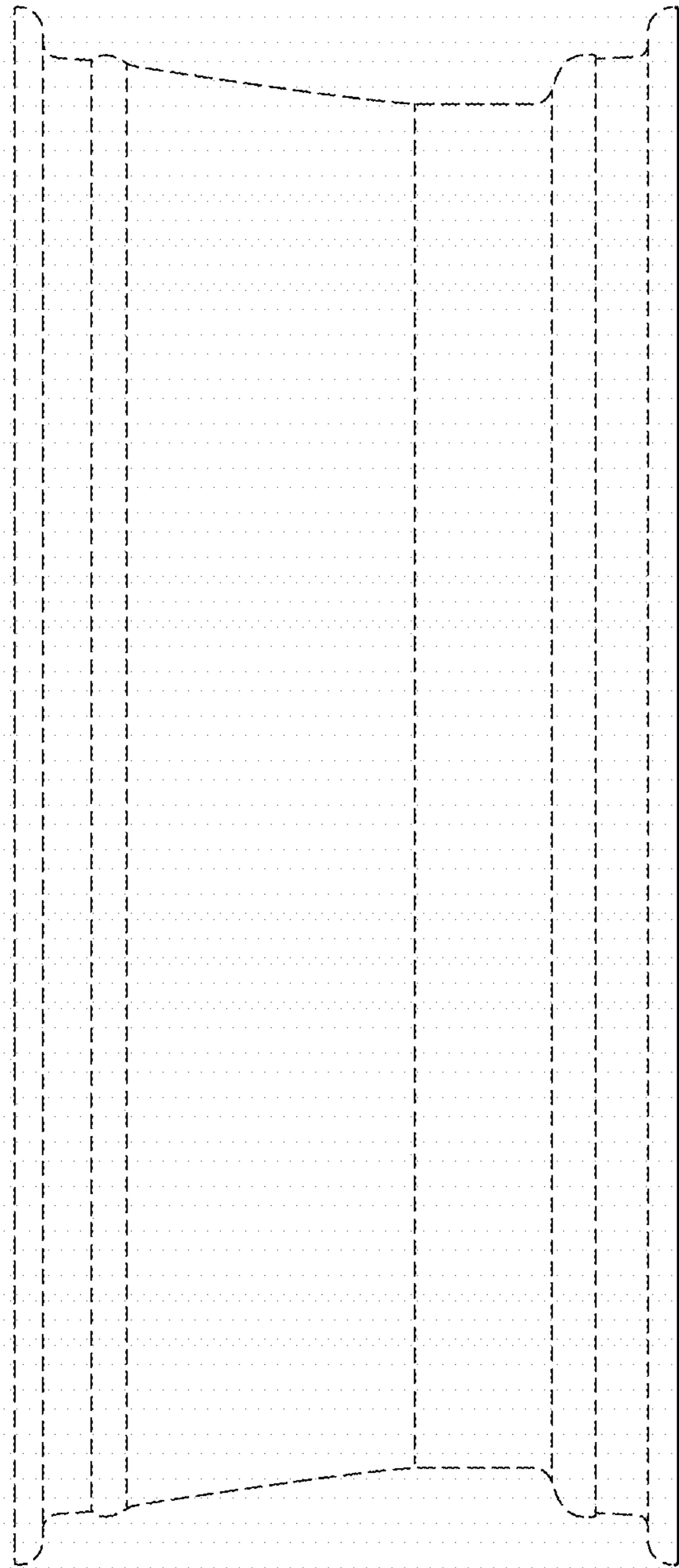

FIG. 3

UNITED STATES PATENT AND TRADEMARK OFFICE
CERTIFICATE OF CORRECTION

PATENT NO. : D849,649 S
APPLICATION NO. : 29/638020
DATED : May 28, 2019
INVENTOR(S) : Dale Grewer

Page 1 of 1

It is certified that error appears in the above-identified patent and that said Letters Patent is hereby corrected as shown below:

On the Title Page

Item (57), under DESCRIPTION, insert preceding the claim: --In Figs. 1-3, the broken lines show environmental structure and form no part of the claimed invention. More specifically, in Figs. 1 and 2, the centrally located broken lines show wheel hub structure, including bolt holes.--.

Signed and Sealed this
Third Day of September, 2019

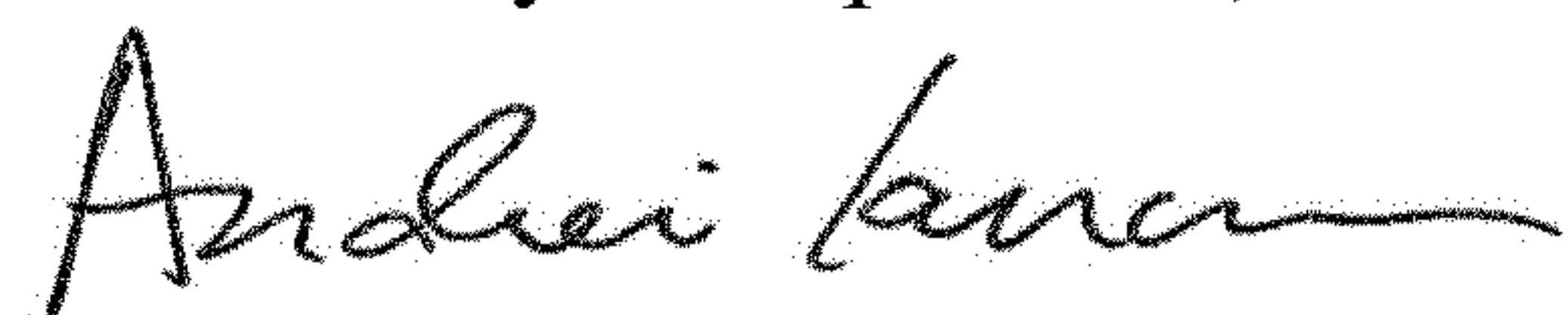

Andrei Iancu
Director of the United States Patent and Trademark Office