



US00D849637S

(12) **United States Design Patent**
Henstridge

(10) **Patent No.:** **US D849,637 S**

(45) **Date of Patent:** **** May 28, 2019**

(54) **WHEEL**

(71) Applicant: **Jaguar Land Rover Limited**, Whitley,
Coventry (GB)

(72) Inventor: **Sean Henstridge**, Coventry (GB)

(73) Assignee: **Jaguar Land Rover Limited**, Whitley,
Coventry (GB)

(**) Term: **15 Years**

(21) Appl. No.: **29/603,404**

(22) Filed: **May 9, 2017**

(30) **Foreign Application Priority Data**

Nov. 11, 2016 (EM) 003459288-0009

Nov. 11, 2016 (EM) 003459288-0010

(51) **LOC (11) Cl.** **12-16**

(52) **U.S. Cl.**
USPC **D12/209**

(58) **Field of Classification Search**

USPC D12/204-213; D21/533, 561, 563

CPC B60B 7/00; B60B 7/02; B60B 7/04; B60B

7/06; B60B 3/02; B60B 3/04; B60B 3/06;

B60B 3/10; B60B 1/00; B60B 1/08;

B60B 1/10; B60B 1/12

See application file for complete search history.

(56) **References Cited**

U.S. PATENT DOCUMENTS

D730,795 S * 6/2015 Mays D12/209

D731,390 S * 6/2015 Kobayashi D12/211

D736,130 S * 8/2015 Wheel D12/209

D737,748 S * 9/2015 Henstridge D12/209

D784,892 S * 4/2017 Groth D12/209

D788,676 S * 6/2017 Payne D12/209

D797,635 S * 9/2017 Rueckheim D12/209

D818,927 S * 5/2018 Valencia Pollex D12/209

D822,573 S * 7/2018 Juergens D12/209

* cited by examiner

Primary Examiner — Sheryl Lane

Assistant Examiner — Calvin E Vansant

(74) *Attorney, Agent, or Firm* — Wood Herron & Evans
LLP

(57) **CLAIM**

The ornamental design for a wheel, as shown and described.

DESCRIPTION

FIG. 1 is a front left perspective view of a wheel for a vehicle according to the present invention.

FIG. 2 is a front view of the wheel shown in FIG. 1

FIG. 3 is a left side view thereof, the right side view being a mirror image thereof.

FIG. 4 is a front left perspective view of a wheel for a vehicle according a second embodiment of the present invention.

FIG. 5 is a front view of the wheel shown in FIG. 4; and, FIG. 6 is a left side view thereof, the right side view being a mirror image thereof.

In FIGS. 1-3, the broken lines show environmental structure and form no part of the claimed invention. More specifically, in FIGS. 1 and 2, the centrally located broken lines show wheel hub structure, including bolt holes.

1 Claim, 4 Drawing Sheets

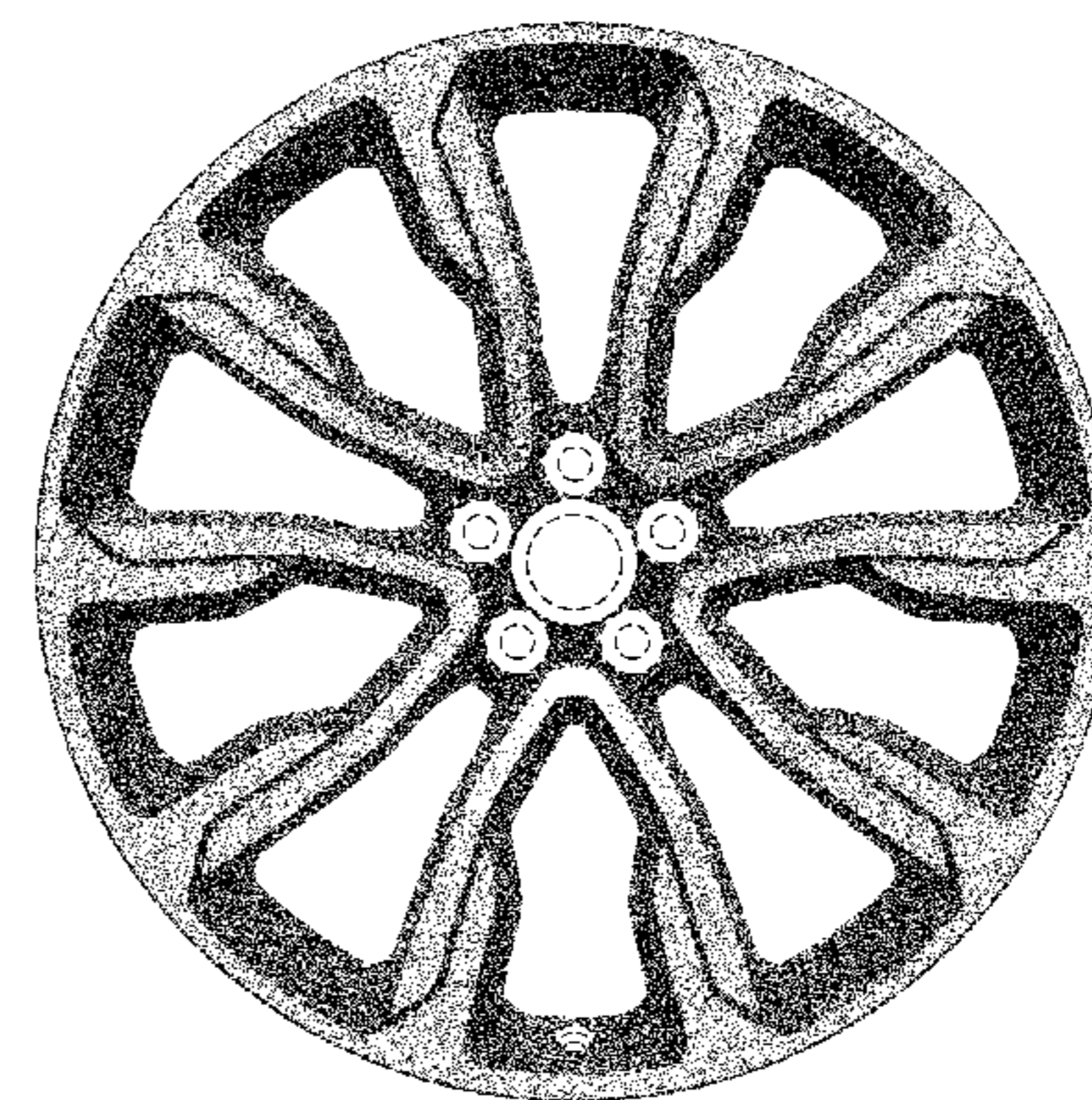
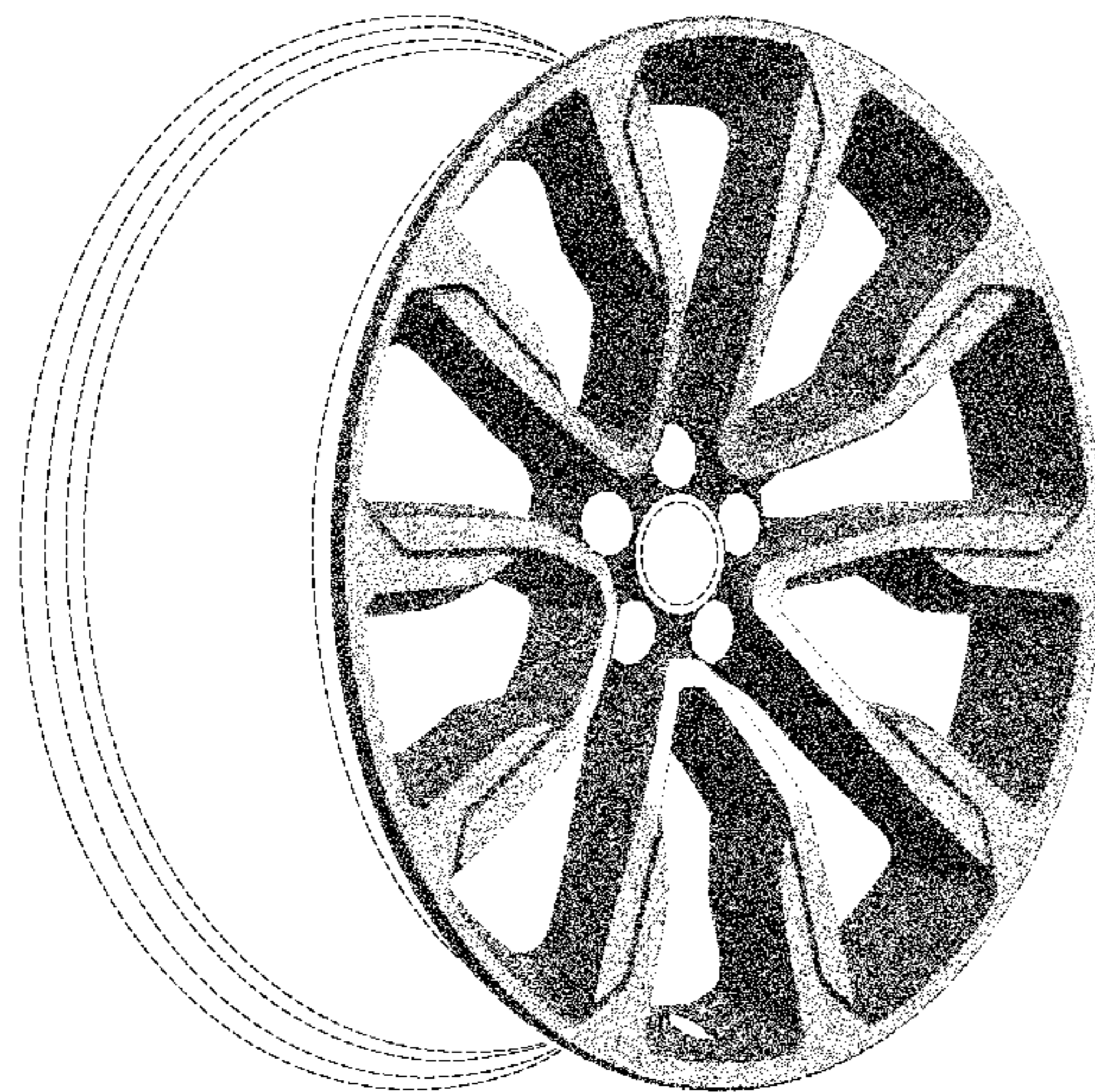

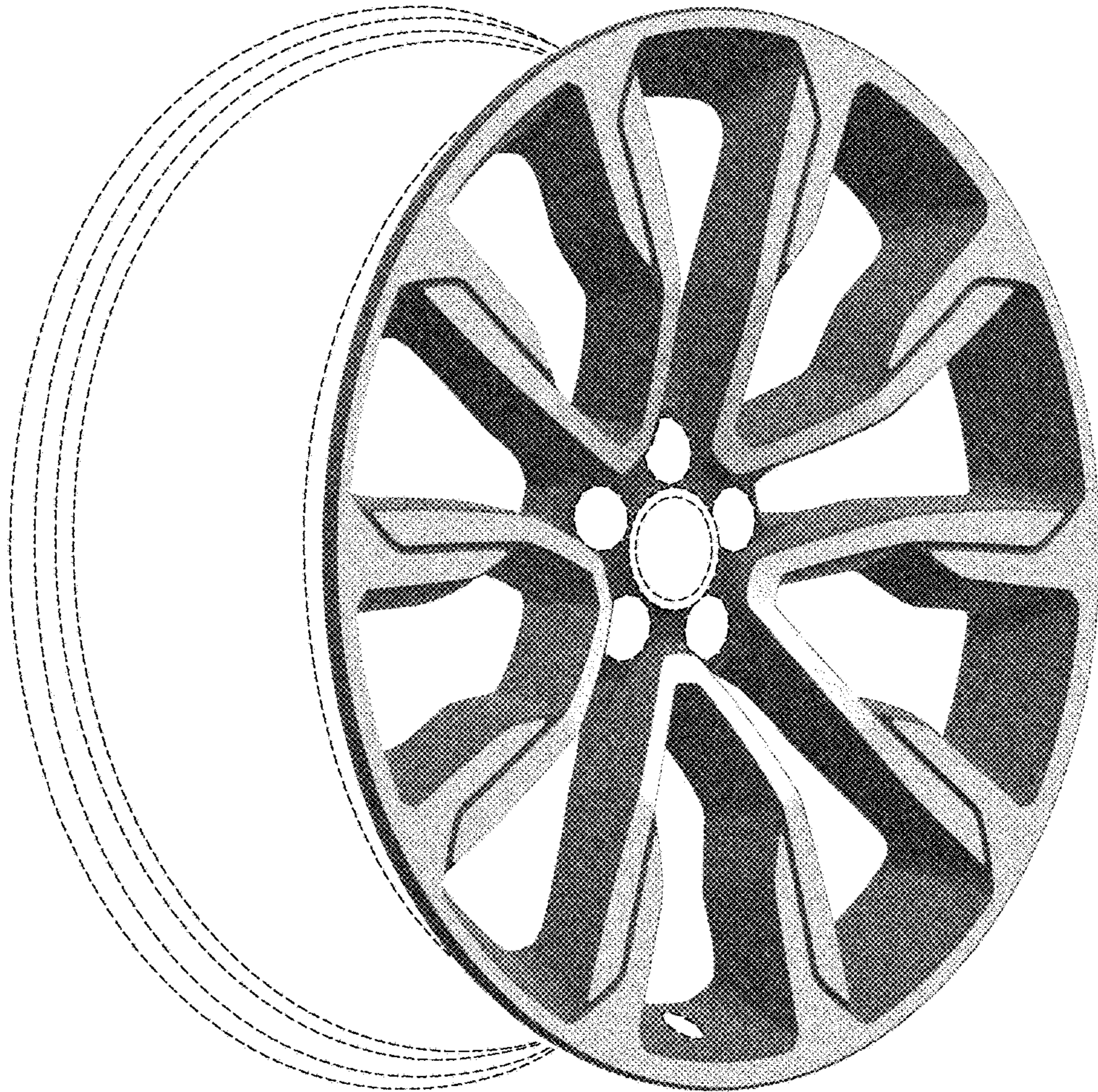

FIG. 1

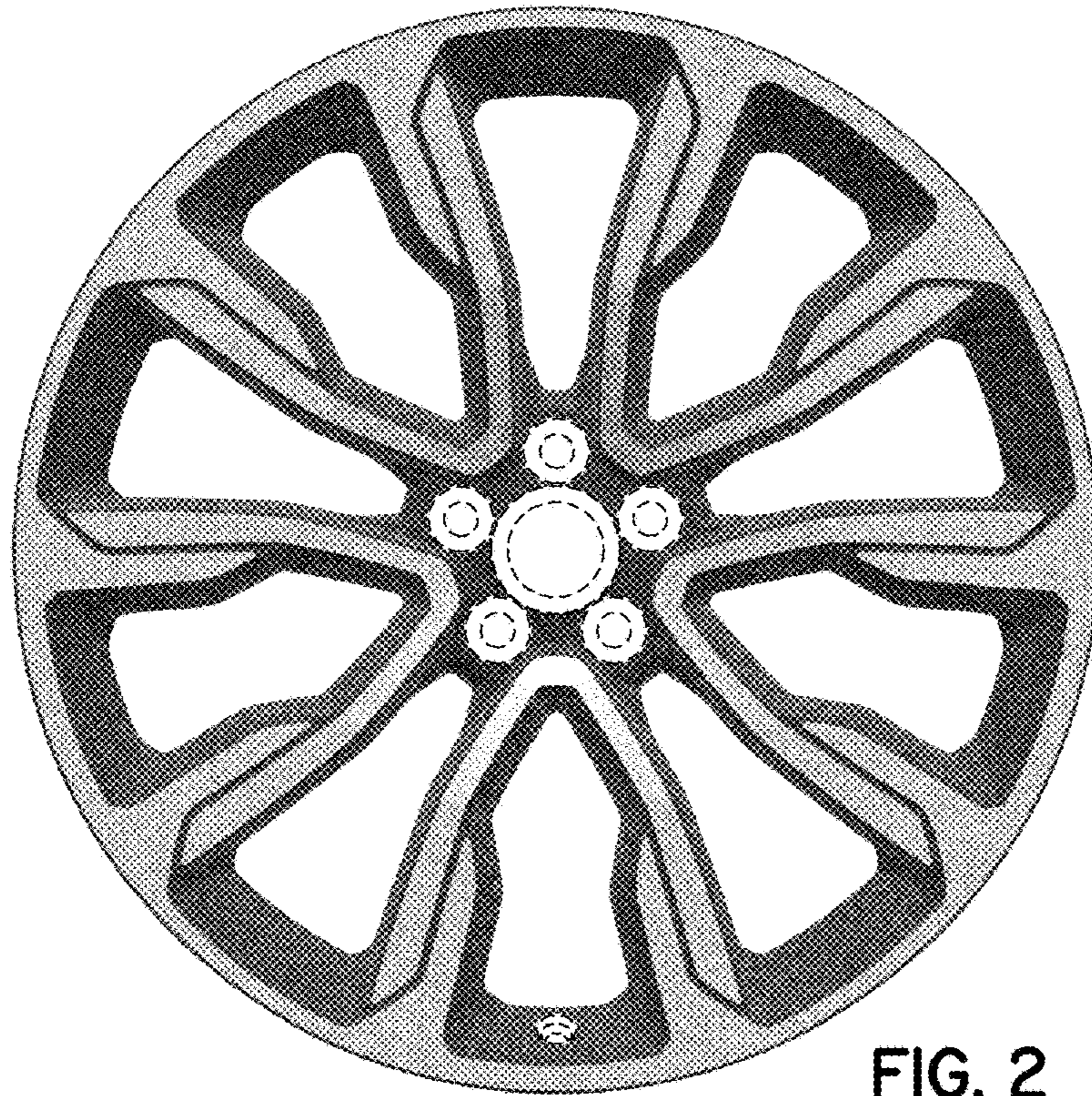

FIG. 2

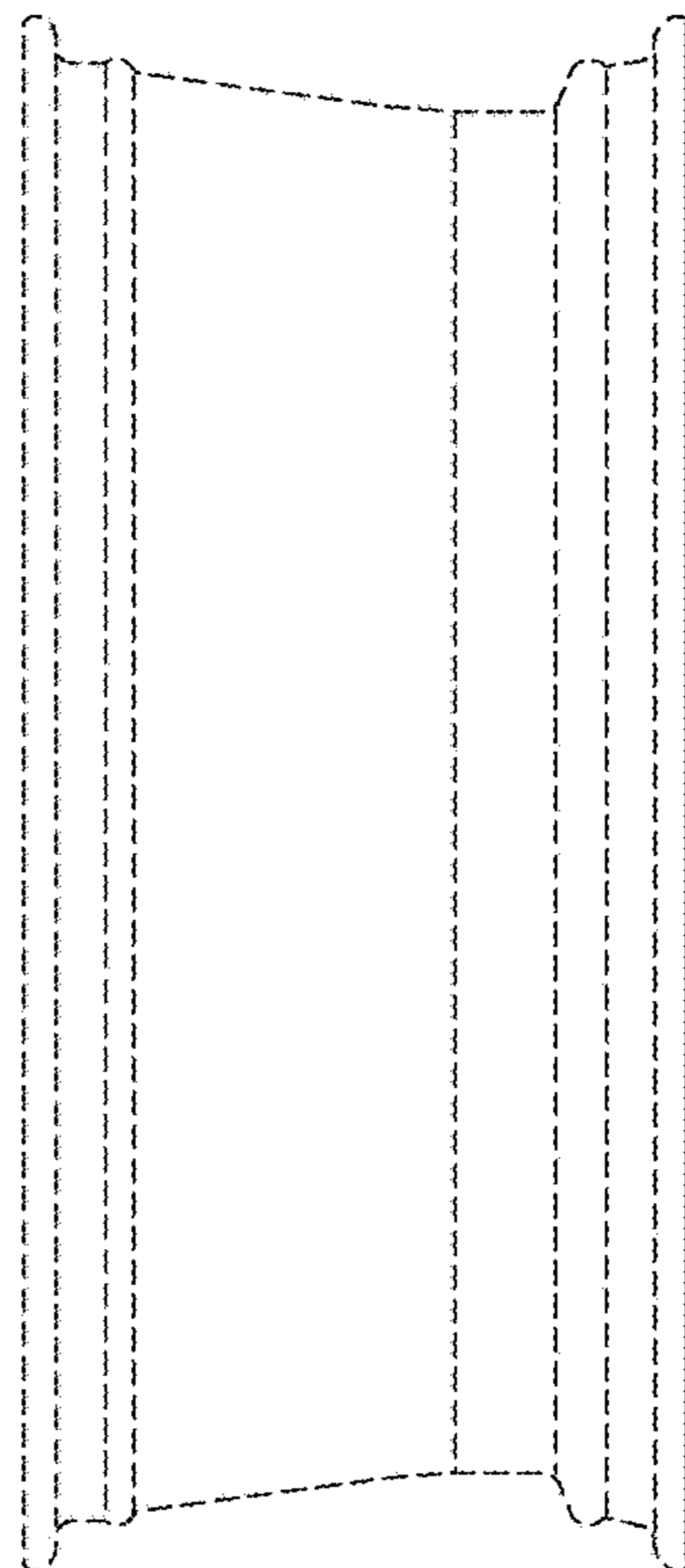

FIG. 3

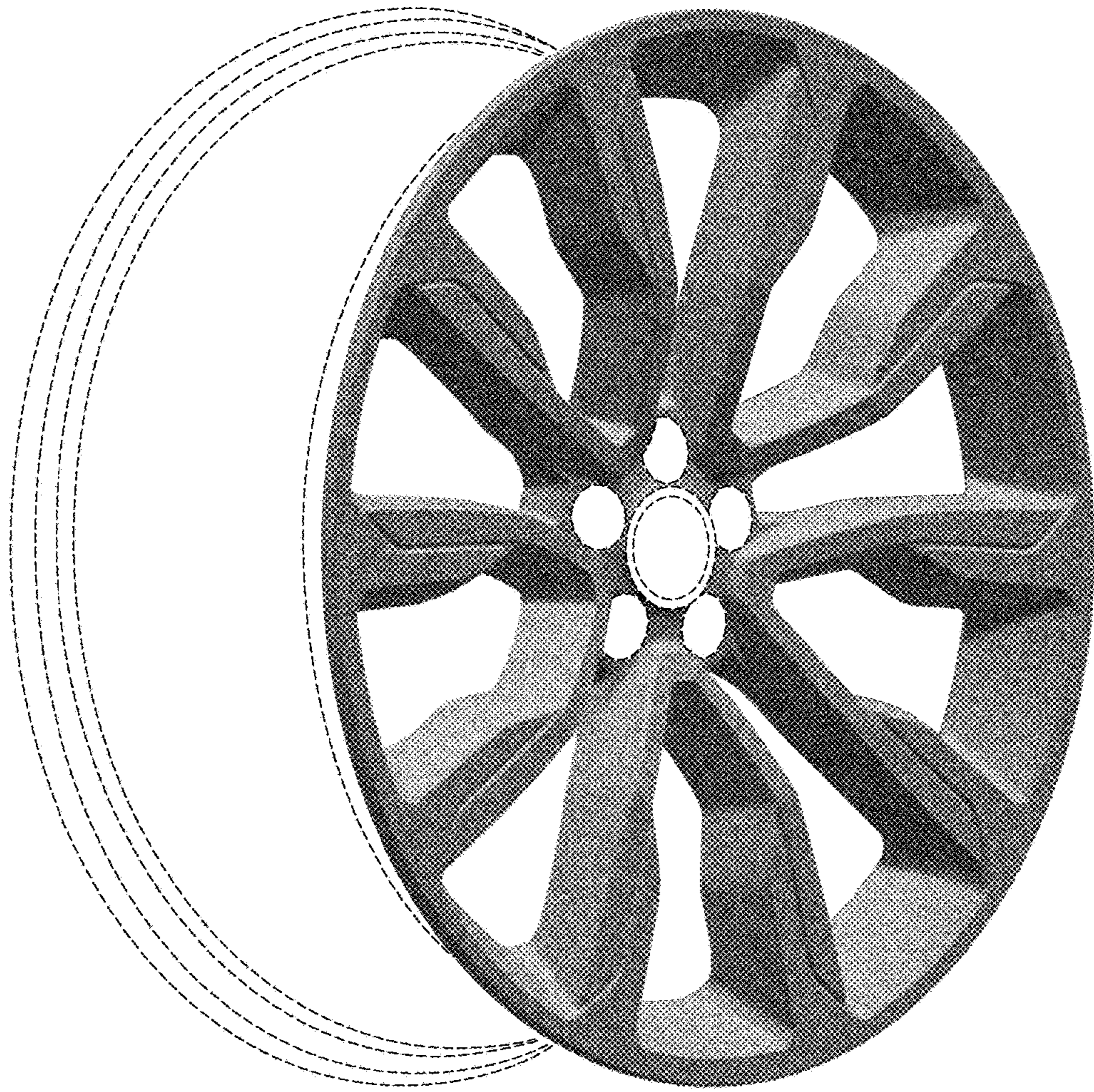

FIG. 4

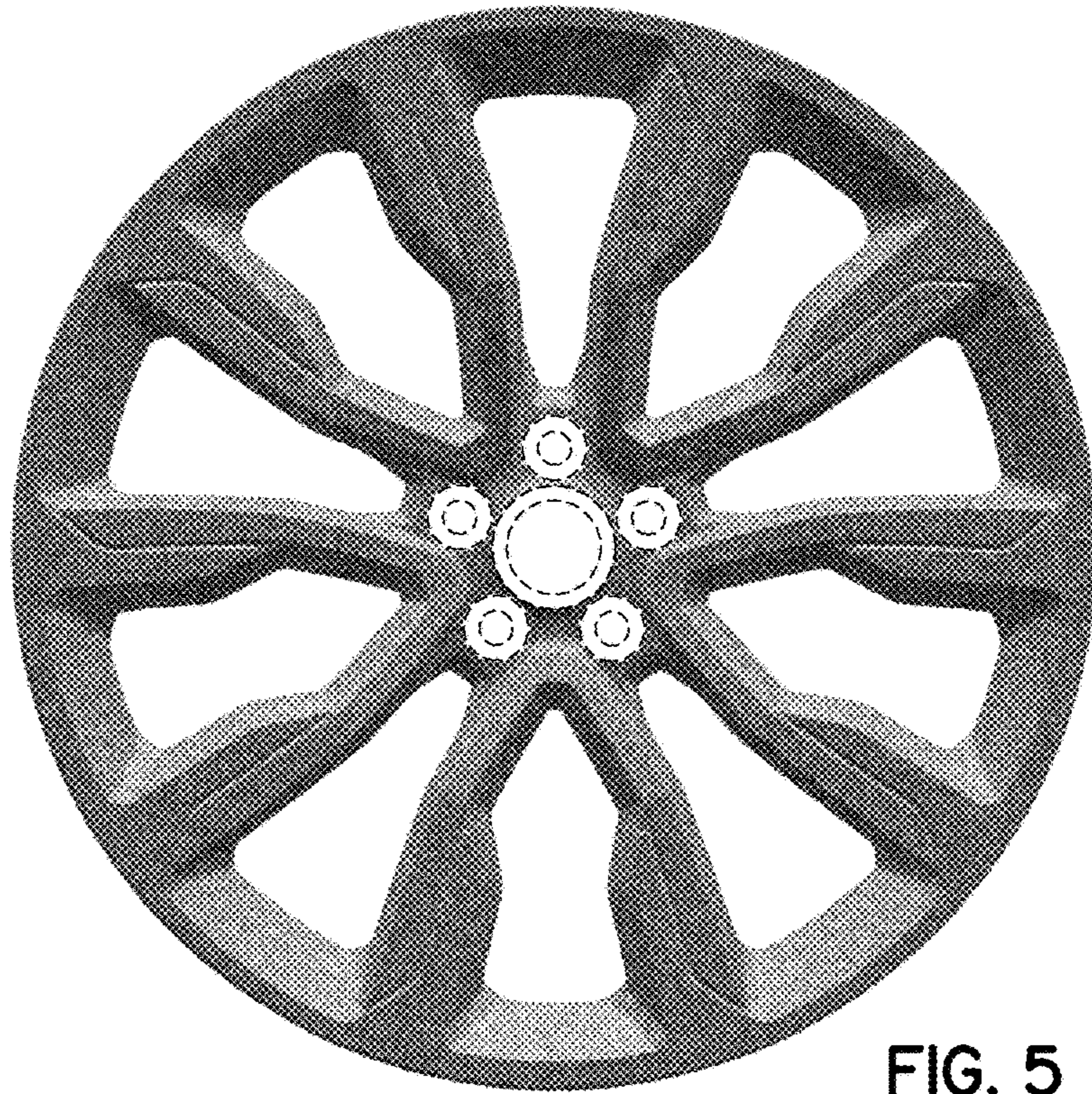

FIG. 5

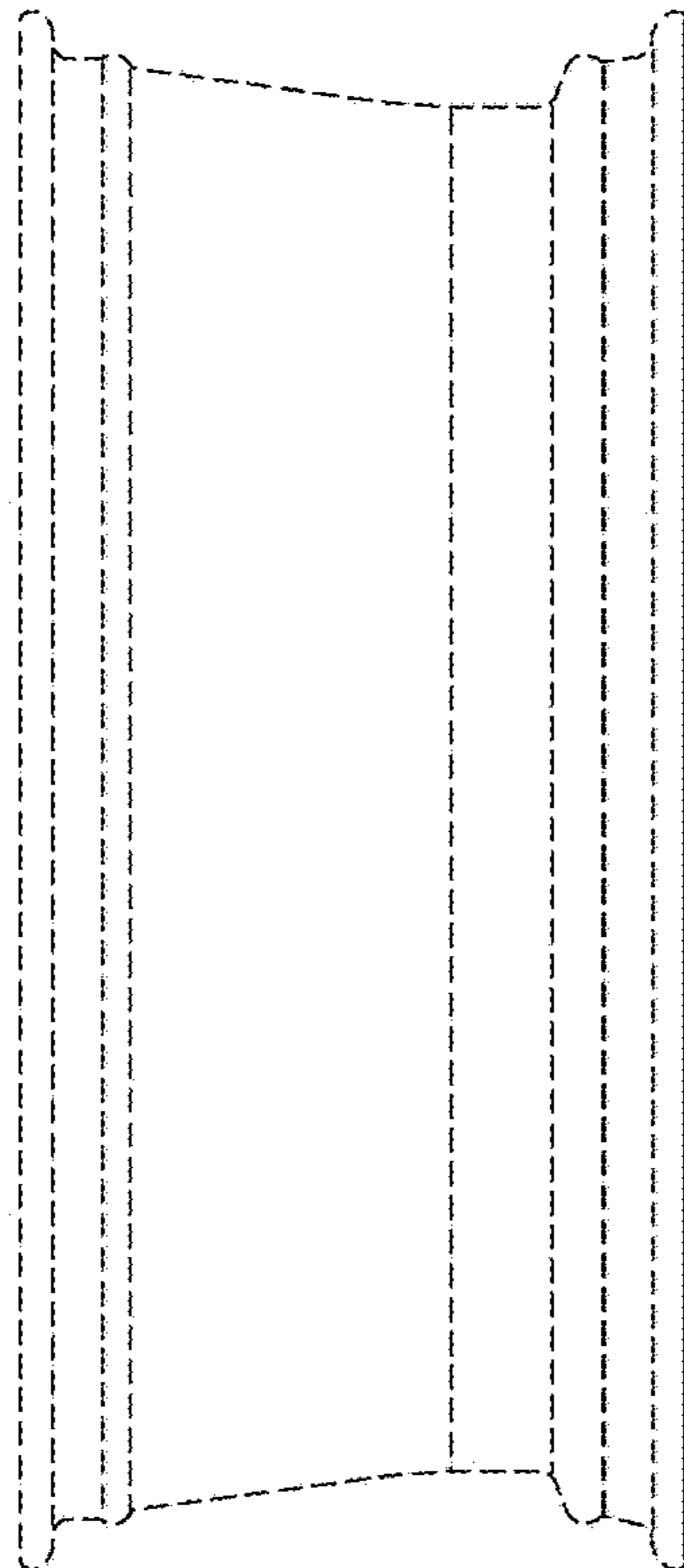

FIG. 6

UNITED STATES PATENT AND TRADEMARK OFFICE
CERTIFICATE OF CORRECTION

PATENT NO. : D849,637 S
APPLICATION NO. : 29/603404
DATED : May 28, 2019
INVENTOR(S) : Sean Henstridge

Page 1 of 1

It is certified that error appears in the above-identified patent and that said Letters Patent is hereby corrected as shown below:

On the Title Page

Item (57) under Description, Lines 6-7 "FIG. 4 is a front left perspective view of a wheel for a vehicle according a second..." should read --FIG. 4 is a front left perspective view of a wheel for a vehicle according to a second...--.

Signed and Sealed this
Sixth Day of August, 2019

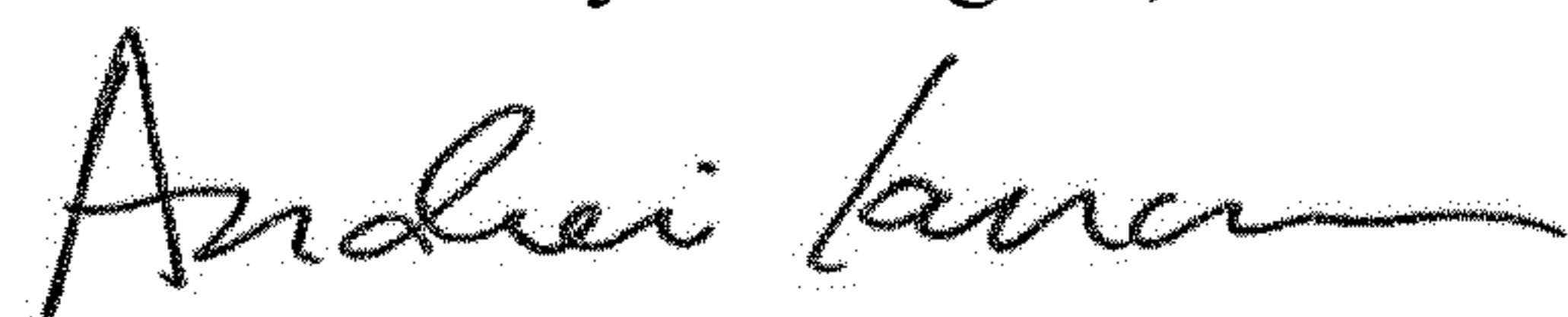

Andrei Iancu
Director of the United States Patent and Trademark Office