



US00D849629S

(12) **United States Design Patent**  
**De Leon**

(10) **Patent No.:** **US D849,629 S**

(45) **Date of Patent:** **\*\* May 28, 2019**

(54) **VEHICLE REAR VALANCE PANEL**

(71) Applicant: **GM GLOBAL TECHNOLOGY OPERATIONS LLC**, Detroit, MI (US)

(72) Inventor: **Reymin De Leon**, Birmingham, MI (US)

(73) Assignee: **GM GLOBAL TECHNOLOGY OPERATIONS LLC**, Detroit, MI (US)

(\*\*) Term: **15 Years**

(21) Appl. No.: **29/629,234**

(22) Filed: **Dec. 12, 2017**

(51) **LOC (11) Cl.** ..... **12-16**

(52) **U.S. Cl.**  
USPC ..... **D12/196**

(58) **Field of Classification Search**  
USPC ..... D12/86, 90, 91, 92, 163, 169, 171, 196, D12/216  
CPC ..... B60R 19/02; B60R 19/04; B62D 25/00; B62D 25/06; B62D 25/08; B62D 35/00  
See application file for complete search history.

(56) **References Cited**

**U.S. PATENT DOCUMENTS**

D570,742 S	6/2008	Takagi et al.
D592,105 S	5/2009	Dean et al.
D597,447 S	8/2009	Folden
D600,595 S	9/2009	Nakamura et al.
D601,925 S	10/2009	O'Donnell
D603,755 S	11/2009	Peters
D604,203 S	11/2009	O'Donnell
D605,082 S	12/2009	Munson
D605,083 S	12/2009	Manoogian, II et al.
D605,977 S	12/2009	Zipfel et al.
D605,978 S	12/2009	Wolff et al.
D608,249 S	1/2010	Peters
D608,690 S	1/2010	Folden et al.

D608,691 S	1/2010	Zak, Jr. et al.
D609,608 S	2/2010	Boniface et al.
D611,387 S	3/2010	Thompson et al.
D611,879 S	3/2010	Kim et al.
D612,297 S	3/2010	Peters et al.
D613,645 S	4/2010	Song et al.
D615,458 S	5/2010	Thompson et al.
D618,595 S	6/2010	Ware et al.
D623,090 S	9/2010	Cox et al.
D627,262 S	11/2010	Ikeda et al.
D635,488 S	4/2011	Phipps
D644,147 S	8/2011	Suh et al.
D644,567 S	9/2011	Kozub
D657,718 S	4/2012	Zipfel et al.
D659,052 S	5/2012	Ware et al.
D659,053 S	5/2012	Ware et al.
D668,182 S	10/2012	Barba Franco et al.
D668,183 S	10/2012	Smart

(Continued)

*Primary Examiner* — Susan Bennett Hattan  
*Assistant Examiner* — Suzanne E Tisdell

(57) **CLAIM**

The ornamental design for a vehicle rear valance panel, as shown and described.

**DESCRIPTION**

FIG. 1 is a front and left perspective view of a vehicle rear valance panel showing my new design; FIG. 2 is a left end elevation view thereof; FIG. 3 is a front elevation view thereof; and, FIG. 4 is a bottom plan view thereof.

The right end elevation view is omitted, because the right end elevation view is a mirror image to the left end elevation view.

The broken lines shown in the drawings depict portions of the vehicle rear valance panel that form no part of the claimed design.

The shade lines in the figures show contour and not surface ornamentation.

**1 Claim, 2 Drawing Sheets**

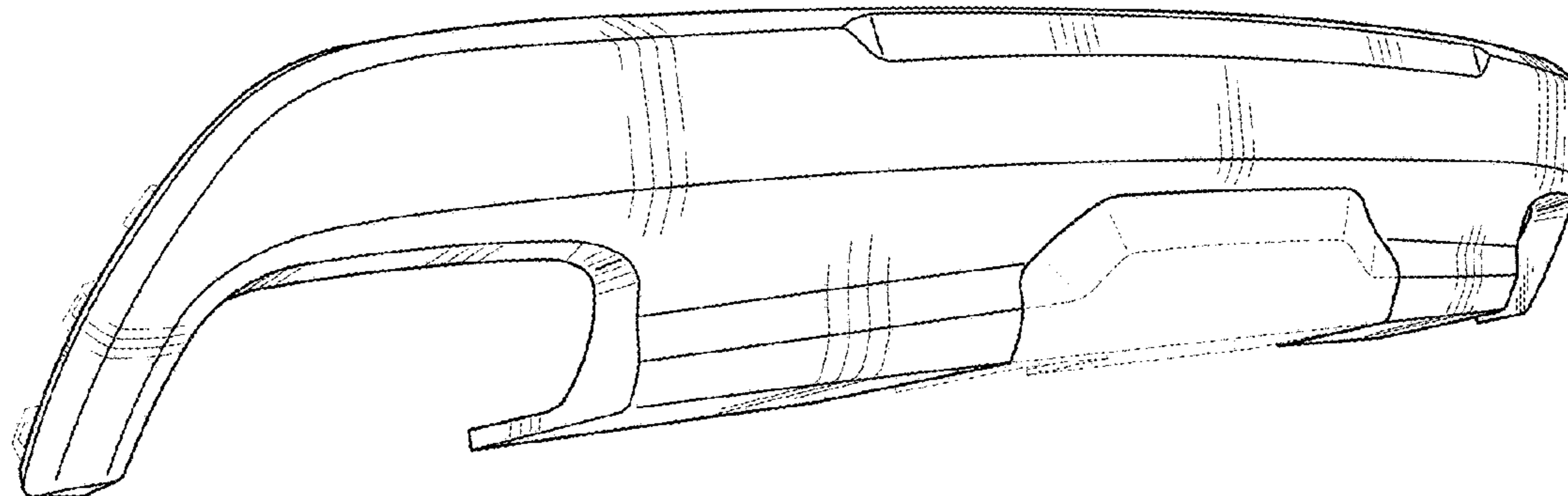

(56)

References Cited

U.S. PATENT DOCUMENTS

D678,820 S	3/2013	Son et al.		D749,250 S	2/2016	Thole et al.	
D678,821 S	3/2013	Ikeda et al.		D749,985 S	2/2016	Kozub et al.	
D680,909 S	4/2013	Munson et al.		D749,997 S	2/2016	McMahan et al.	
D680,910 S	4/2013	David		D750,001 S	2/2016	Thole et al.	
D684,899 S	6/2013	Baker		D751,003 S	*	3/2016	Rupar ..... D12/163
D686,536 S	7/2013	McCabe et al.		D751,007 S	*	3/2016	Curic ..... D12/169
D692,798 S	11/2013	Thurber		D753,032 S		4/2016	Smith et al.
D692,799 S	11/2013	Smith et al.		D753,033 S		4/2016	Thole et al.
D696,157 S	12/2013	Loeb		D753,034 S		4/2016	Thole et al.
D698,708 S	*	2/2014	Rupar ..... D12/169	D753,035 S		4/2016	Boniface et al.
D699,629 S		2/2014	Ikeda et al.	D753,036 S	*	4/2016	Curic ..... D12/169
D700,871 S		3/2014	O'Donnell et al.	D753,559 S		4/2016	McMahan et al.
D701,800 S	*	4/2014	Campbell ..... D12/169	D753,560 S		4/2016	McMahan et al.
D703,103 S		4/2014	Lee	D753,567 S		4/2016	Boniface et al.
D704,103 S		5/2014	Mack et al.	D754,571 S		4/2016	Boniface et al.
D705,132 S		5/2014	Ware et al.	D754,572 S		4/2016	McMahan et al.
D705,699 S		5/2014	Ware et al.	D755,088 S		5/2016	McMahan et al.
D711,653 S	*	8/2014	Pacetti ..... D3/318	D756,869 S		5/2016	McMahan et al.
D712,322 S	*	9/2014	Kobayashi ..... D12/169	D758,259 S	*	6/2016	Messale ..... D12/169
D712,805 S	*	9/2014	Murkett ..... D12/169	D758,271 S		6/2016	McMahan et al.
D713,298 S		9/2014	Dyson	D762,147 S	*	7/2016	Messale ..... D12/169
D713,764 S		9/2014	Ferlazzo et al.	D763,143 S	*	8/2016	Varga ..... D12/169
D716,696 S		11/2014	Thole et al.	D763,744 S	*	8/2016	Behmer ..... D12/169
D716,706 S		11/2014	Thole et al.	D764,975 S		8/2016	Aengenheyster
D716,709 S		11/2014	Thole et al.	D764,976 S		8/2016	Aengenheyster
D717,696 S		11/2014	Thole et al.	D767,449 S		9/2016	Pevovar et al.
D718,189 S		11/2014	Krieg et al.	D767,450 S		9/2016	Lee et al.
D718,683 S		12/2014	Thole et al.	D767,451 S		9/2016	Kozub et al.
D722,282 S		2/2015	Loeb	D767,454 S		9/2016	McMahan et al.
D722,533 S		2/2015	Thole et al.	D767,458 S		9/2016	Kim
D722,534 S		2/2015	Munson et al.	D767,459 S		9/2016	Kim
D724,510 S		3/2015	McMahan et al.	D767,460 S		9/2016	Kozub et al.
D725,001 S		3/2015	McMahan et al.	D767,461 S		9/2016	Kozub et al.
D726,591 S		4/2015	Jacob	D771,528 S		11/2016	Smith et al.
D730,776 S		6/2015	Smart	D771,529 S		11/2016	Thole et al.
D730,783 S		6/2015	Henriques et al.	D771,532 S		11/2016	Kapitonov
D732,427 S		6/2015	Loeb	D771,533 S		11/2016	Kapitonov
D732,429 S		6/2015	Loeb	D771,536 S	*	11/2016	Wolff ..... D12/169
D732,430 S		6/2015	Loeb	D772,766 S		11/2016	Kozub et al.
D732,431 S		6/2015	Loeb	D772,767 S		11/2016	Kim
D732,432 S		6/2015	Aengenheyster	D773,084 S		11/2016	Kapitonov
D732,433 S		6/2015	Aengenheyster	D773,086 S		11/2016	McCabe et al.
D732,435 S		6/2015	Mackay	D774,226 S		12/2016	McCabe et al.
D733,002 S		6/2015	Loeb	D775,003 S		12/2016	Pevovar et al.
D735,611 S		8/2015	Aengenheyster	D775,007 S		12/2016	Thole et al.
D735,627 S		8/2015	Smith	D775,010 S		12/2016	Kim et al.
D736,451 S		8/2015	Smith	D775,038 S	*	12/2016	Frascella ..... D12/169
D739,306 S		9/2015	McMahan et al.	D775,049 S		12/2016	Scheer et al.
D739,317 S		9/2015	McMahan et al.	D775,549 S		1/2017	Karras
D741,223 S		10/2015	Kim et al.	D775,554 S		1/2017	Kapitonov
D742,119 S	*	11/2015	Batista ..... D3/318	D776,020 S		1/2017	Kapitonov
D743,309 S		11/2015	Thole et al.	D776,021 S	*	1/2017	Kapitonov ..... D12/169
D743,313 S		11/2015	Smith et al.	D776,581 S		1/2017	Pevovar et al.
D743,314 S		11/2015	Thole et al.	D776,583 S		1/2017	Scheer et al.
D743,857 S		11/2015	McMahan et al.	D776,841 S		1/2017	Kozub et al.
D744,158 S		11/2015	Willett et al.	D776,843 S		1/2017	McCabe et al.
D744,915 S	*	12/2015	Curic ..... D12/169	D776,846 S		1/2017	Willett et al.
D745,086 S		12/2015	Finos et al.	D777,359 S		1/2017	Kozub et al.
D745,719 S		12/2015	Boniface et al.	D777,360 S		1/2017	Kozub et al.
D745,725 S		12/2015	McMahan et al.	D777,361 S		1/2017	Kozub et al.
D745,726 S		12/2015	McMahan et al.	D777,604 S		1/2017	McNerney
D745,837 S		12/2015	Smith et al.	D777,605 S		1/2017	Ferlazzo et al.
D746,726 S		1/2016	Smith et al.	D777,620 S		1/2017	Pevovar et al.
D746,727 S		1/2016	Smith et al.	D777,621 S		1/2017	Kim
D746,728 S		1/2016	Smith et al.	D777,622 S		1/2017	Kozub et al.
D746,729 S		1/2016	Boniface et al.	D777,628 S		1/2017	Kozub et al.
D746,730 S		1/2016	Kim et al.	D777,955 S		1/2017	Willett et al.
D747,514 S		1/2016	McMahan et al.	D778,212 S		2/2017	Kozub et al.
D747,515 S		1/2016	McMahan et al.	D778,215 S		2/2017	Kozub et al.
D747,819 S		1/2016	Thole et al.	D780,064 S		2/2017	Smith et al.
D749,021 S		2/2016	Boniface et al.	D780,067 S		2/2017	Zipfel et al.
D749,026 S		2/2016	Smith et al.	D780,068 S		2/2017	Whitla et al.
D749,027 S		2/2016	McMahan et al.	D780,077 S		2/2017	Kim et al.
D749,246 S		2/2016	Thole et al.	D780,081 S		2/2017	Lee
D749,249 S		2/2016	Thole et al.	D780,084 S		2/2017	Scheer et al.
				D780,631 S		3/2017	Kozub et al.
				D780,644 S		3/2017	Kim et al.
				D781,184 S		3/2017	Thole et al.
				D781,192 S		3/2017	Kozub et al.

(56)

References Cited

U.S. PATENT DOCUMENTS

D781,586 S *	3/2017	Reinhart .....	D3/318	D793,297 S	8/2017	Smith et al.	
D781,587 S *	3/2017	Mangano .....	D3/318	D793,299 S	8/2017	Krieg et al.	
D782,379 S	3/2017	Wassell		D793,300 S	8/2017	Krieg et al.	
D783,482 S	4/2017	Smith et al.		D793,301 S	8/2017	Kozub	
D784,213 S	4/2017	Karras		D793,302 S	8/2017	Kozub	
D784,223 S	4/2017	Lee		D793,311 S	8/2017	Whitla et al.	
D784,226 S	4/2017	Cheng		D793,590 S	8/2017	Kozub et al.	
D784,579 S	4/2017	Cheng et al.		D793,591 S	8/2017	Kozub et al.	
D784,877 S	4/2017	Lee		D793,917 S	8/2017	Kozub	
D784,886 S	4/2017	Smith et al.		D793,918 S	8/2017	Kozub	
D785,521 S	5/2017	Smith et al.		D794,229 S	8/2017	Barry	
D786,149 S	5/2017	Pevovar et al.		D794,230 S	8/2017	Kozub	
D786,743 S	5/2017	Smith et al.		D795,747 S	8/2017	Bailie	
D786,750 S	5/2017	Lee		D795,757 S	8/2017	Pevovar et al.	
D787,446 S	5/2017	Cockerill		D795,758 S	8/2017	Karras	
D787,984 S	5/2017	Fang		D795,759 S	8/2017	Kozub et al.	
D787,988 S	5/2017	Lee		D795,760 S	8/2017	Kozub et al.	
D787,989 S	5/2017	Kozub et al.		D795,762 S	8/2017	Lee	
D787,990 S	5/2017	Kozub et al.		D795,763 S	8/2017	Kozub	
D787,992 S	5/2017	Lee		D796,088 S	8/2017	McCabe et al.	
D787,993 S	5/2017	McCabe et al.		D796,093 S	8/2017	Mainville	
D788,001 S	5/2017	Lee		D796,390 S	9/2017	Pevovar et al.	
D788,641 S	6/2017	Arnold		D797,456 S *	9/2017	Chen .....	D3/318
D788,644 S	6/2017	Mueller		D797,537 S	9/2017	Cooper et al.	
D788,645 S	6/2017	Mueller		D797,603 S	9/2017	Noone et al.	
D789,250 S	6/2017	Arnold		D797,614 S	9/2017	Lee	
D789,260 S	6/2017	Smith		D797,616 S *	9/2017	Lee .....	D12/169
D789,575 S	6/2017	Willett		D797,624 S	9/2017	Nakamura	
D789,841 S	6/2017	Lee		D797,625 S	9/2017	Perkins	
D789,849 S	6/2017	Lee		D797,631 S	9/2017	Pevovar et al.	
D791,018 S	7/2017	Mylenek		D797,632 S	9/2017	Zipfel et al.	
D791,644 S	7/2017	Fang		D797,967 S	9/2017	Barry	
D792,290 S	7/2017	Smith et al.		D797,970 S	9/2017	Mainville	
D792,293 S	7/2017	McCabe et al.		D797,971 S	9/2017	Mainville	
D792,294 S	7/2017	McCabe et al.		D797,972 S	9/2017	Whitla et al.	
D792,295 S	7/2017	McCabe et al.		D798,201 S *	9/2017	Zavatski .....	D12/169
D792,815 S	7/2017	Kozub		D798,204 S	9/2017	Mainville	
D792,816 S	7/2017	Kozub		D799,384 S	10/2017	Kozub et al.	
D793,290 S	8/2017	Kozub		D799,385 S	10/2017	Kozub et al.	
D793,292 S	8/2017	Lee		D799,386 S	10/2017	Kozub et al.	
D793,293 S	8/2017	Lee et al.		D799,728 S	10/2017	Whitla et al.	
D793,294 S *	8/2017	Lee .....	D12/169	D800,621 S *	10/2017	Bucher .....	D12/196
D793,295 S *	8/2017	McCabe .....	D12/169	D801,236 S *	10/2017	Kozub .....	D12/169
D793,296 S	8/2017	Smith et al.		D803,738 S *	11/2017	Granlund .....	D12/169
				D807,255 S *	1/2018	Piscitelli .....	D12/169

\* cited by examiner

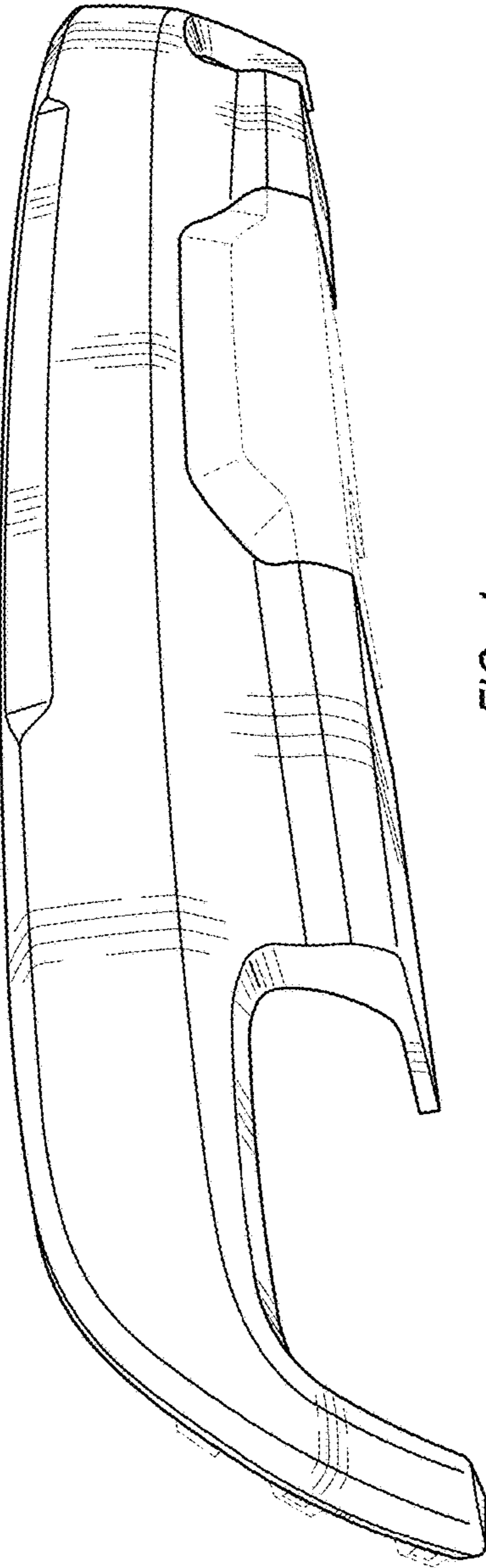

FIG-1

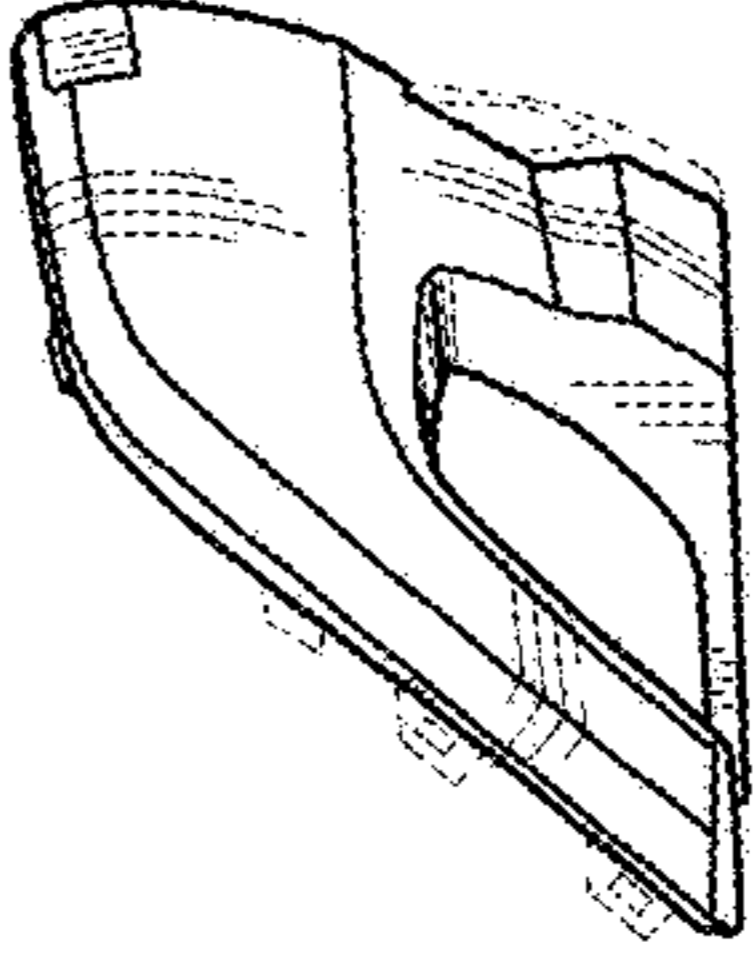

FIG-2

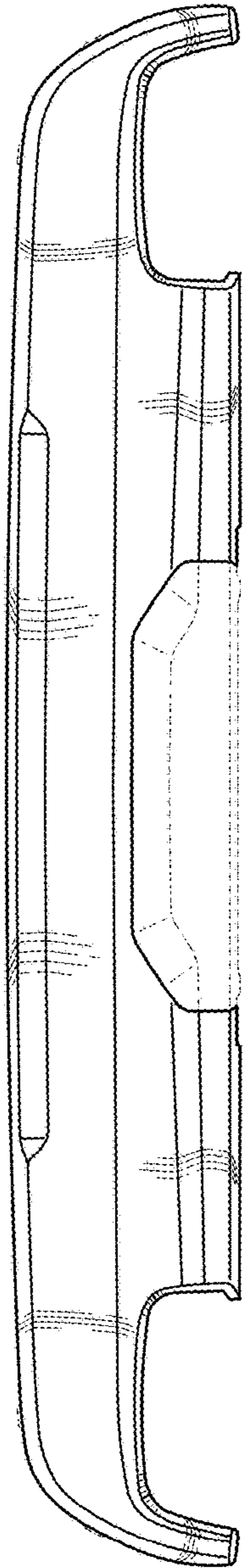

FIG-3

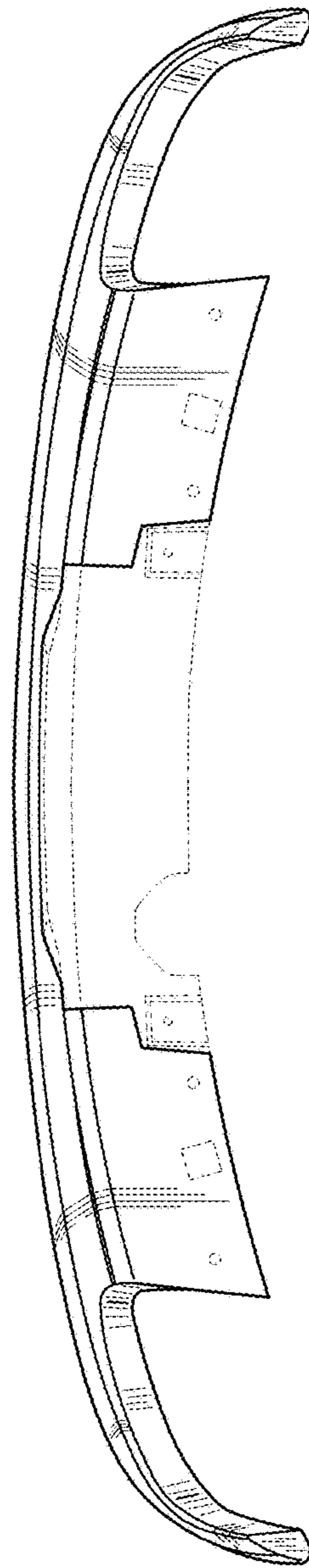

FIG-4