



US00D849587S

(12) **United States Design Patent** (10) **Patent No.:** **US D849,587 S**
Li (45) **Date of Patent:** **** May 28, 2019**

(54) **SURROUND ASSEMBLY**

- (71) Applicant: **Xiaoxiao Li**, Toronto (CA)
- (72) Inventor: **Xiaoxiao Li**, Toronto (CA)
- (**) Term: **15 Years**

(21) Appl. No.: **29/574,855**

(22) Filed: **Aug. 18, 2016**

(51) **LOC (11) Cl.** **11-01**

(52) **U.S. Cl.**
USPC **D11/79**

(58) **Field of Classification Search**

USPC D11/1, 2, 7, 8, 11, 16, 17, 24, 27, 40,
D11/41-44, 56, 66, 70, 75, 76, 79, 81,
D11/86, 89, 97, 99, 103, 108, 121, 184,
D11/202, 212, 228; D3/18-27
CPC . A44C 13/00; A44C 17/0225; A44C 17/0241;
A44C 25/00; A44C 25/001; A44C
25/002; A44C 25/004; A44C 25/005;
A44C 25/007

See application file for complete search history.

(56) **References Cited**

U.S. PATENT DOCUMENTS

471,734	A *	3/1892	Maier	G02C 11/00 2/249
D193,404	S *	8/1962	Telford	D11/26
D294,335	S *	2/1988	Gatsos	D11/43
4,984,683	A *	1/1991	Eller	A44C 25/004 206/38
4,991,409	A *	2/1991	Creates	A44C 9/0046 63/15.7
5,167,356	A *	12/1992	Williams	A44C 25/00 206/8
5,305,934	A *	4/1994	Grey	A45F 5/00 224/617
5,893,198	A *	4/1999	DeCotis	A44C 5/2038 224/617
D473,371	S *	4/2003	Bronstein	D3/26
D517,940	S *	3/2006	Stern	D11/86
D518,406	S *	4/2006	Stern	D11/86
D644,563	S *	9/2011	Demaree	D11/221
9,824,310	B2 *	11/2017	Huynh	G06K 19/07762

OTHER PUBLICATIONS

Hand Embroidered Mini Embroidery Hoop Necklace (available online Oct. 13, 2015) Retrieved from the internet Dec. 28, 2017, retrieved from URL: <https://www.etsy.com/shop/PlaidLoveThreads/reviews?ref=pagination&page=8>.*

Ring and Charm Holder Necklace (available online 0/15/2016) Retrieved from the internet Feb. 7, 2018, retrieved from URL: https://www.amazon.com/Necklace-Ali-Art-Handmade-Girlfriend/dp/B01H4QU14M?ref=hdn_dp_car_mba_3.*

Ring Holder Necklace (available online) Retrieved from the internet Feb. 7, 2018, retrieved from URL: https://www.amazon.com/Necklace-Ali-Art-Holder-Only-Engagement/dp/B074DDMK73?ref=hdn_dp_car_mba_9.*

Embroidery Hoop (available online Aug. 8, 2016) Retrieved from the internet Dec. 28, 2017, retrieved from URL: <https://www.facebook.com/loopyinlove/photos/a.787468178052494.1073741828.787056508093661/882389461893698/?type=3&theater>.*

Healifty Mini Embroidery Hoop Frame (available online) Retrieved from the internet Jan. 3, 2018 from URL: https://www.amazon.com/Healifty-Embroidery-Wooden-Square-Stitch/dp/B07D6PBM6T/ref=sr_1_1?ie=UTF8&qid=1546546393&sr=8-1&keywords=Healifty+Mini+Embroidery+Hoop+Frame+Wooden+Square+Cross+Stitch+Hoop+Ring+DIY+Crafts+E.*

DIY Mini Embroidery Hoop Frame (available online) Retrieved from the internet Jan. 3, 2018 from URL: https://www.etongmarket.com/index.php?main_page=product_info&products_id=14401.*

Rectangle Hoop DIY Necklace Kit (available online) Retrieved from the internet Jan. 3, 2018 from URL: <https://www.etsy.com/listing/575962295/50x30mm-rectangle-hoop-diy-necklace-kit?ref=related-3&frs=1>.*

Square-Embroidery-Hoop (available online) Retrieved from the internet Jan. 3, 2018 from URL: <https://ae01.alicdn.com/kf/HTB19lxuoCfD8KJjSszhq6zlJFXad/WRMOM-Mini-30x30mm-Square-Embroidery-Hoop-DIY-Tiny-Embroidery-Hoop-Frame%E2%80%A6%201/1>.*

TheMarshWrenShop, "DIY Embroidery Necklace Setting Pendant Acrylic DIY Cross Stitch Needlework Plastic Oval Jewelry Mirror Black Red Acrylic", www.etsy.com/ca/listing/448872404/diy-embroidery-necklace-setting-pendant, retrieved Dec. 4, 2016.

TheMarshWrenShop, "DIY Embroidery Necklace Setting *Set of 5* Pendant Setting Walnut DIY Cross Stitch Needlework Wood MDF Rectangle Oval or Circle Jewelry", www.etsy.com/ca/listing/235953392/diy-embroidery-necklace-setting-set-of-5, retrieved Dec. 13, 2016.

MousselineCreations, "On Sale-20% off Antique embroidery necklace, embroidery pendant, antique necklace, Brass locket, pink and white necklace", www.etsy.com/ca/listing/237595485/antique-embroidery-necklace-embroidery, retrieved Dec. 4, 2016.

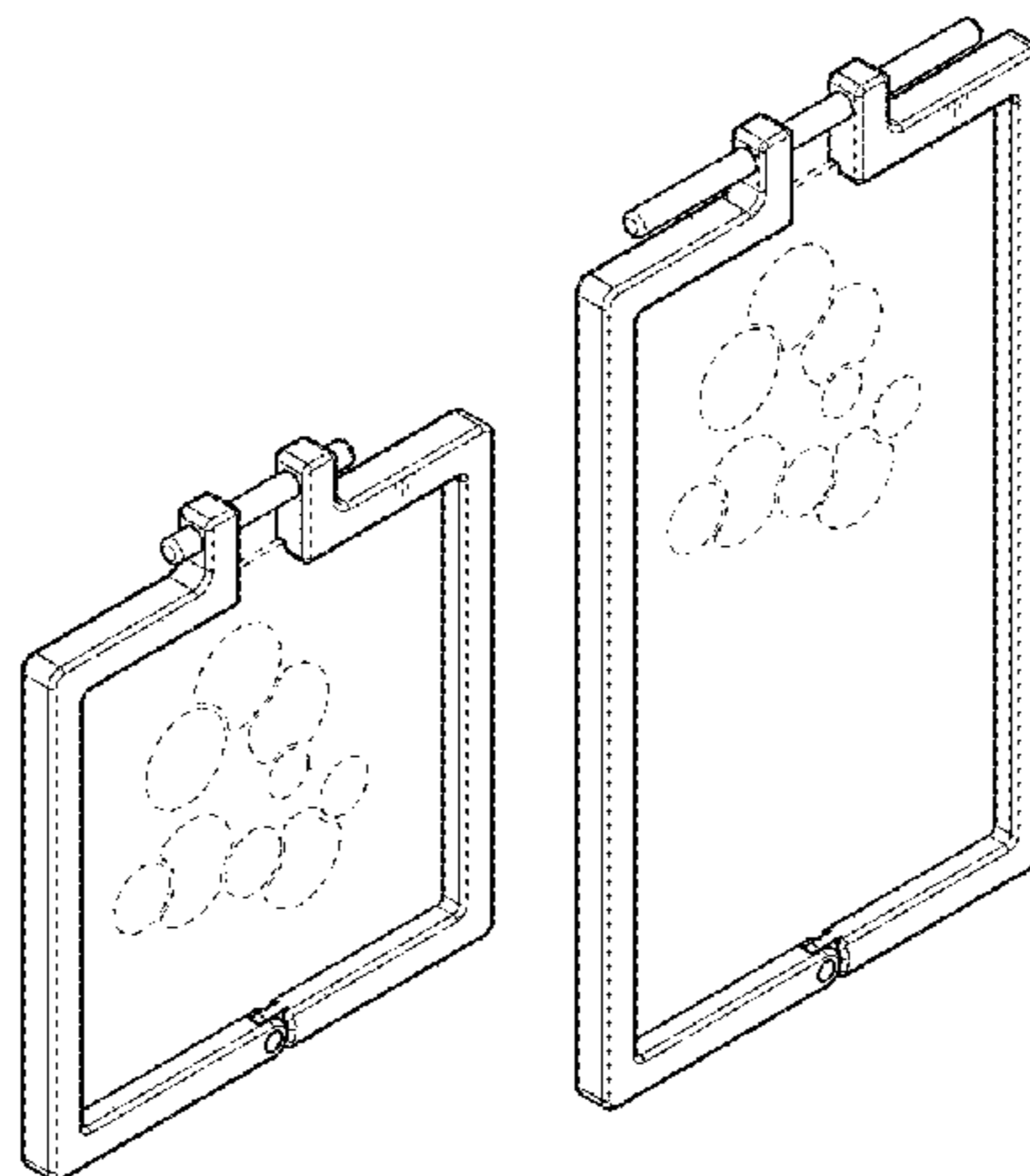

Buligaia, "Valentine's day gift, Hearts necklace, embroidered necklace, Best friend Necklace, mini hoop necklace, embroidery necklace", www.etsy.com/ca/listing/235297979/valentines-day-gift-hearts-necklace, retrieved Dec. 4, 2016.
http://sucal.redocn.com/shenghuobaike_4677926.html, retrieved Dec. 4, 2016.

* cited by examiner

Primary Examiner — Kevin K Rudzinski
Assistant Examiner — Richard Kearney
 (74) *Attorney, Agent, or Firm* — Millman IP Inc.

(57) **CLAIM**

The ornamental design for a surround assembly, as shown and described.

DESCRIPTION

FIG. 1 is a perspective view from above, to the front and one side of a first embodiment of the new design for a surround assembly with artwork inside shown in broken lines;
 FIG. 2 is a perspective view from above, to the front and one side of the first embodiment of the new design without artwork inside;
 FIG. 3 is a front elevation view thereof;
 FIG. 4 is a top view thereof;
 FIG. 5 is a left side elevation view thereof;
 FIG. 6 is a rear elevation view thereof;
 FIG. 7 is a bottom view thereof;
 FIG. 8 is a right side elevation view thereof;
 FIG. 9 is a perspective view from above, to the front and one side of a second embodiment of the new design for a surround assembly with the artwork inside shown in broken lines;
 FIG. 10 is a perspective view from above, to the front and one side of the second embodiment of the new design for a surround assembly without the artwork inside;
 FIG. 11 is a front elevation view thereof;
 FIG. 12 is a top view thereof;
 FIG. 13 is a left side elevation view thereof;
 FIG. 14 is a rear elevation view thereof;
 FIG. 15 is a bottom view thereof;
 FIG. 16 is a right side elevation view thereof;
 FIG. 17 is a perspective view from above, to the front and one side of a third embodiment of the new design for a surround assembly with the artwork inside shown in broken lines;
 FIG. 18 is a perspective view from above, to the front and one side of the third embodiment of the new design for a surround assembly without the artwork inside;
 FIG. 19 is a front elevation view thereof;
 FIG. 20 is a top view thereof;
 FIG. 21 is a left side elevation view thereof;
 FIG. 22 is a rear elevation view thereof;
 FIG. 23 is a bottom view thereof;
 FIG. 24 is a right side elevation view thereof;

FIG. 25 is a perspective view from above, to the front and one side of a fourth embodiment of the new design for a surround assembly with the artwork inside shown in broken lines;
 FIG. 26 is a perspective view from above, to the front and one side of the fourth embodiment of the new design for a surround assembly without the artwork inside;
 FIG. 27 is a front elevation view thereof;
 FIG. 28 is a top view thereof;
 FIG. 29 is a left side elevation view thereof;
 FIG. 30 is a rear elevation view thereof;
 FIG. 31 is a bottom view thereof;
 FIG. 32 is a right side elevation view thereof;
 FIG. 33 is a perspective view from above, to the front and one side of a fifth embodiment of the new design for a surround assembly with the artwork inside shown in broken lines;
 FIG. 34 is a perspective view from above, to the front and one side of the fifth embodiment of the new design for a surround assembly without the artwork inside;
 FIG. 35 is a front elevation view thereof;
 FIG. 36 is a top view thereof;
 FIG. 37 is a left side elevation view thereof;
 FIG. 38 is a rear elevation view thereof;
 FIG. 39 is a bottom view thereof;
 FIG. 40 is a right side elevation view thereof;
 FIG. 41 is a perspective view from above, to the front and one side of a sixth embodiment of the new design for a surround assembly with the artwork inside shown in broken lines;
 FIG. 42 is a perspective view from above, to the front and one side of the sixth embodiment of the new design for a surround assembly without the artwork inside;
 FIG. 43 is a front elevation view thereof;
 FIG. 44 is a top view thereof;
 FIG. 45 is a left side elevation view thereof;
 FIG. 46 is a rear elevation view thereof;
 FIG. 47 is a bottom view thereof;
 FIG. 48 is a right side elevation view thereof;
 FIG. 49 is a perspective view from above, to the front and one side of a seventh embodiment of the new design for a surround assembly with the artwork inside shown in broken lines;
 FIG. 50 is a perspective view from above, to the front and one side of the seventh embodiment of the new design for a surround assembly without the artwork inside;
 FIG. 51 is a front elevation view thereof;
 FIG. 52 is a top view thereof;
 FIG. 53 is a left side elevation view thereof;
 FIG. 54 is a rear elevation view thereof;
 FIG. 55 is a bottom view thereof; and,
 FIG. 56 is a right side elevation view thereof.
 The broken lines shown in the drawings illustrate environmental structure that forms no part of the claimed design. The surround assembly is shown with symbolic break-lines in its length; the appearance of any portion of the article between the break-lines forms no part of the claimed design.

1 Claim, 18 Drawing Sheets

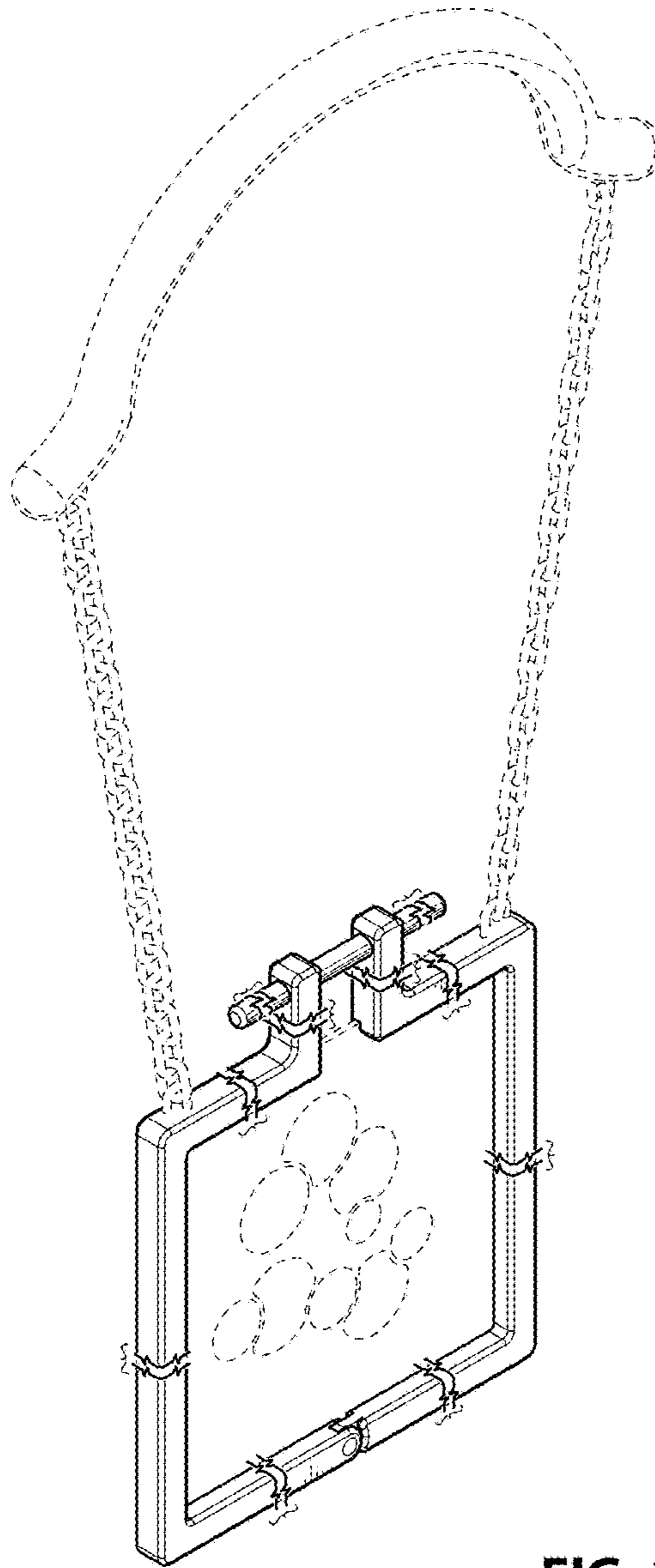

FIG. 1

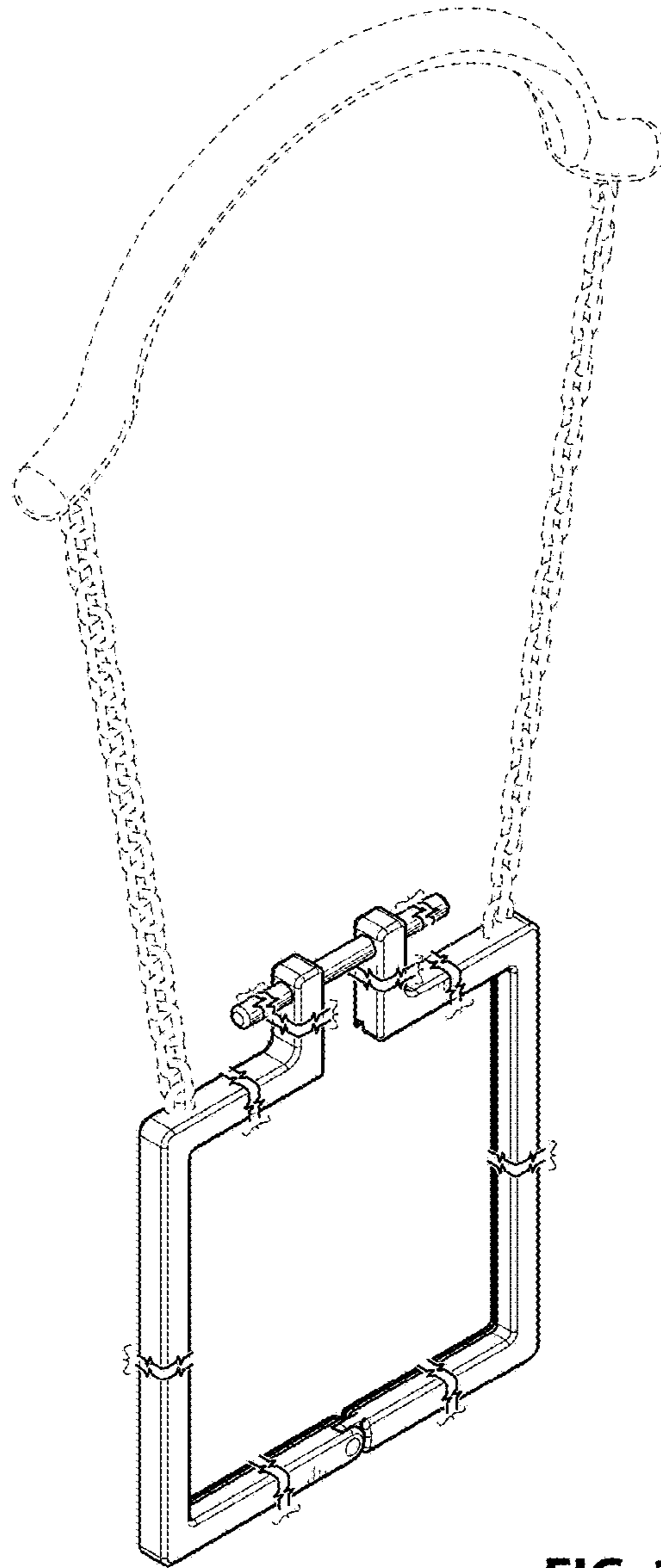

FIG. 2

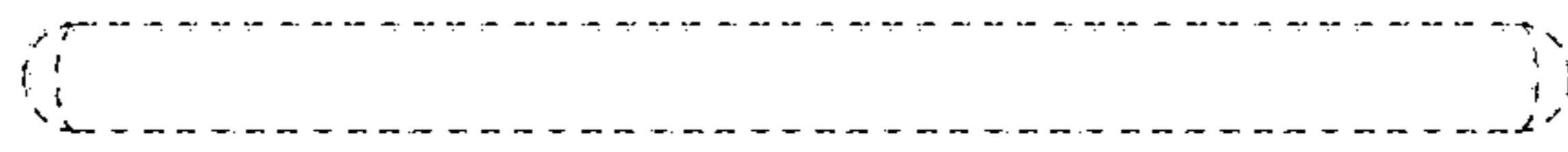

FIG. 4

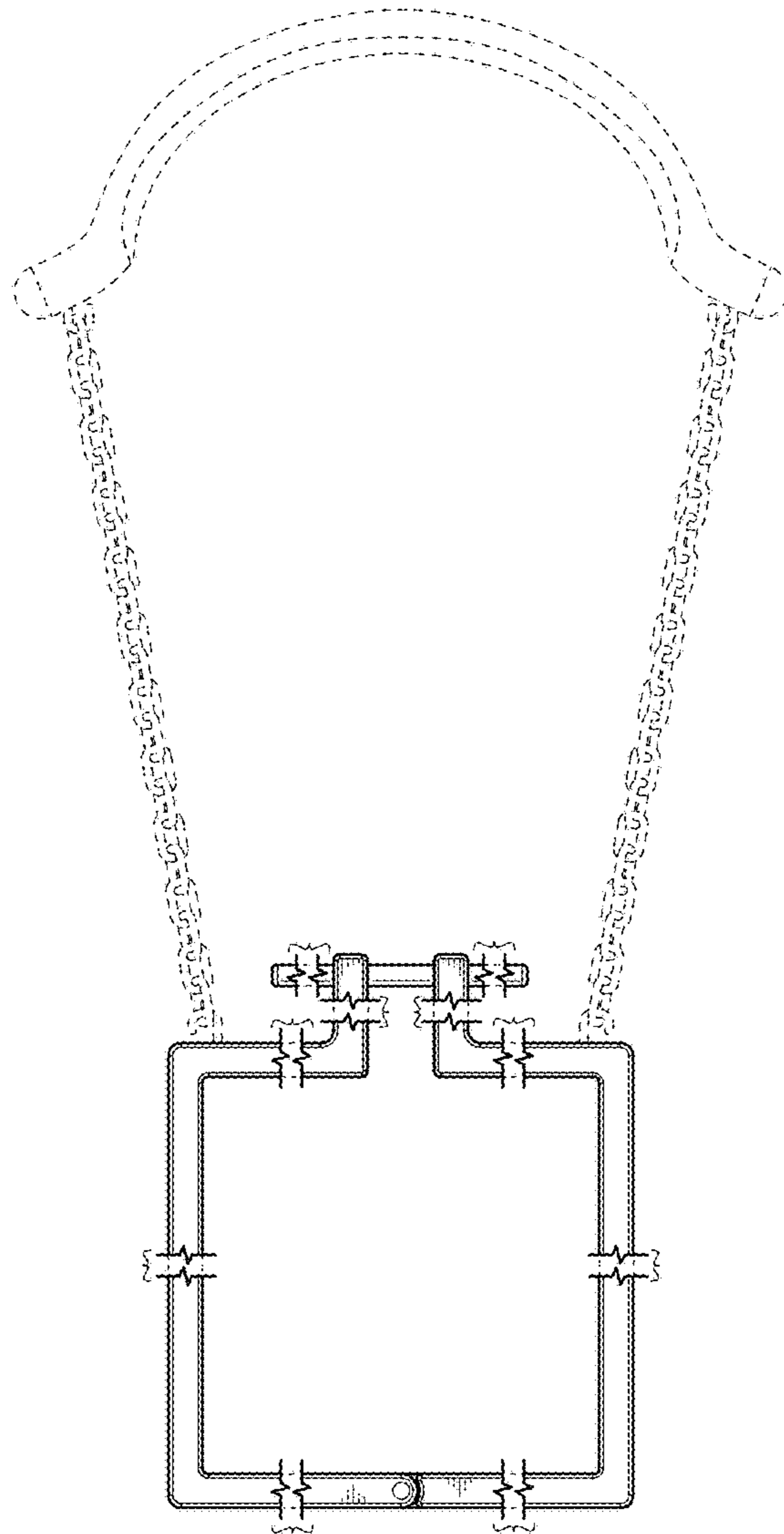

FIG. 3

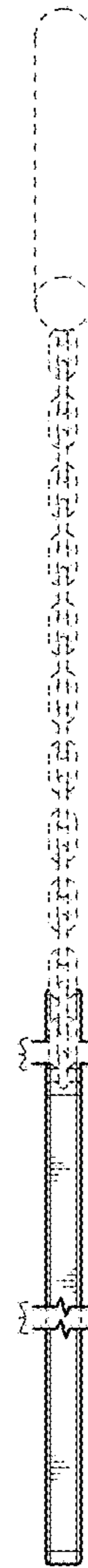

FIG. 5

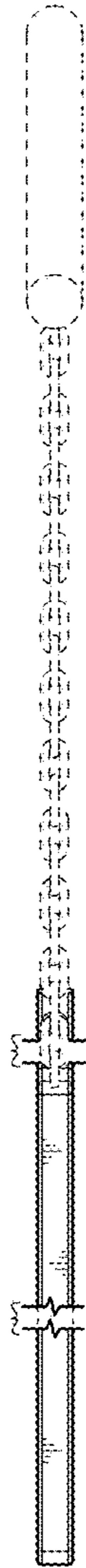

FIG. 8

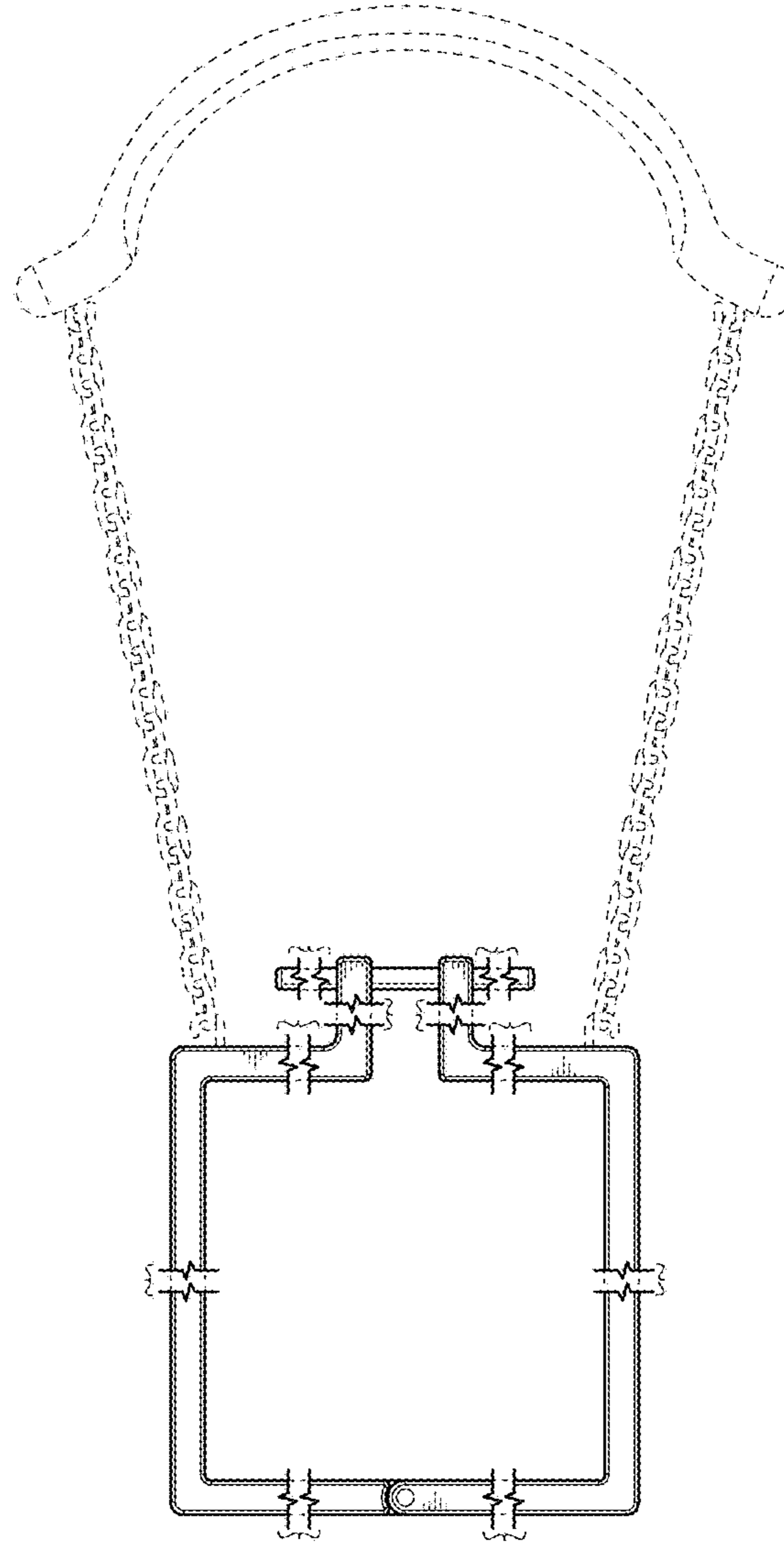

FIG. 6

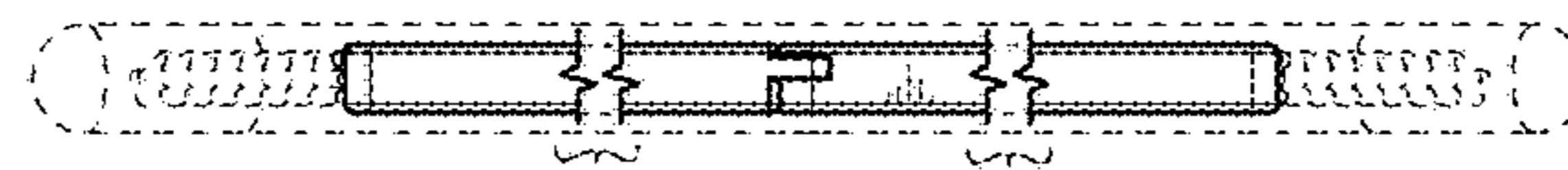

FIG. 7

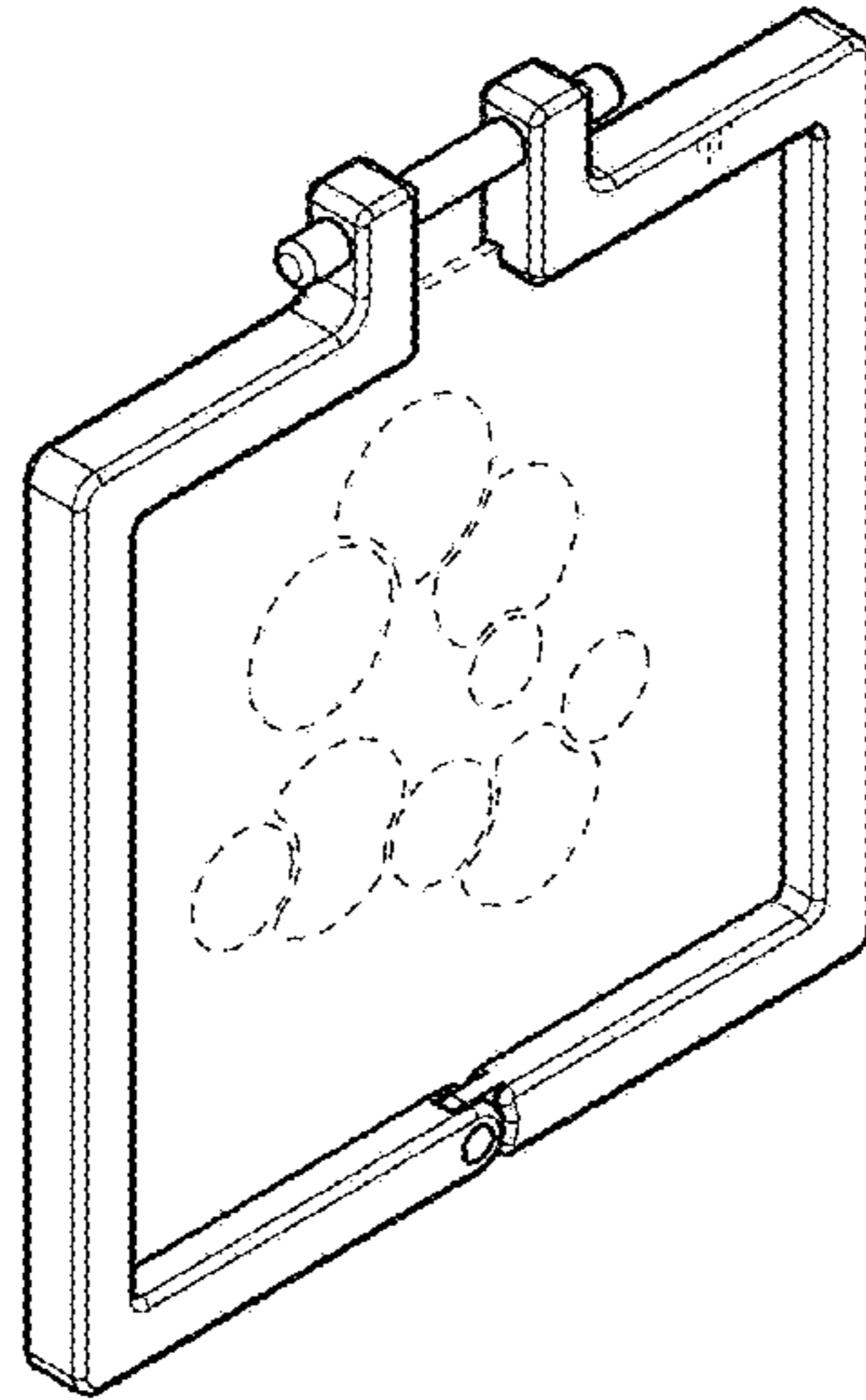

FIG. 9

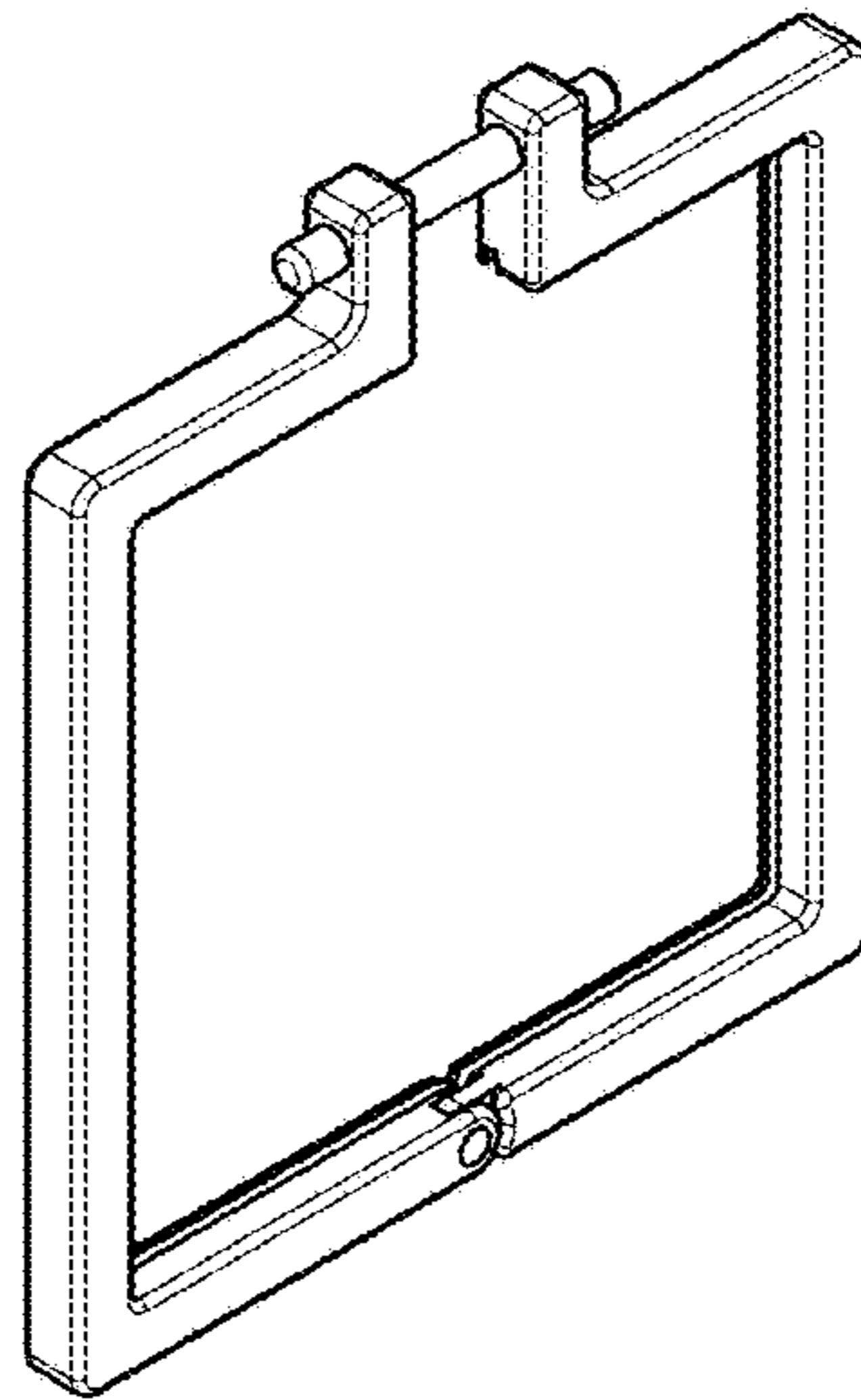

FIG. 10

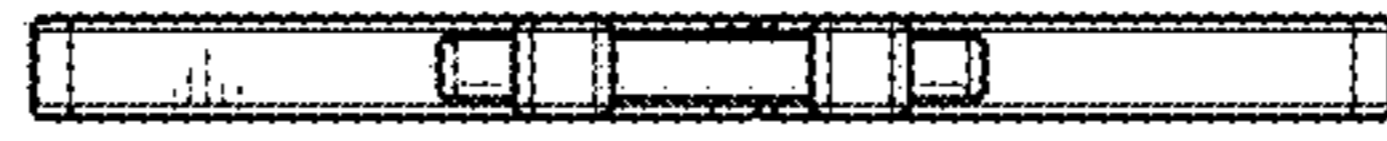

FIG. 12



FIG. 16

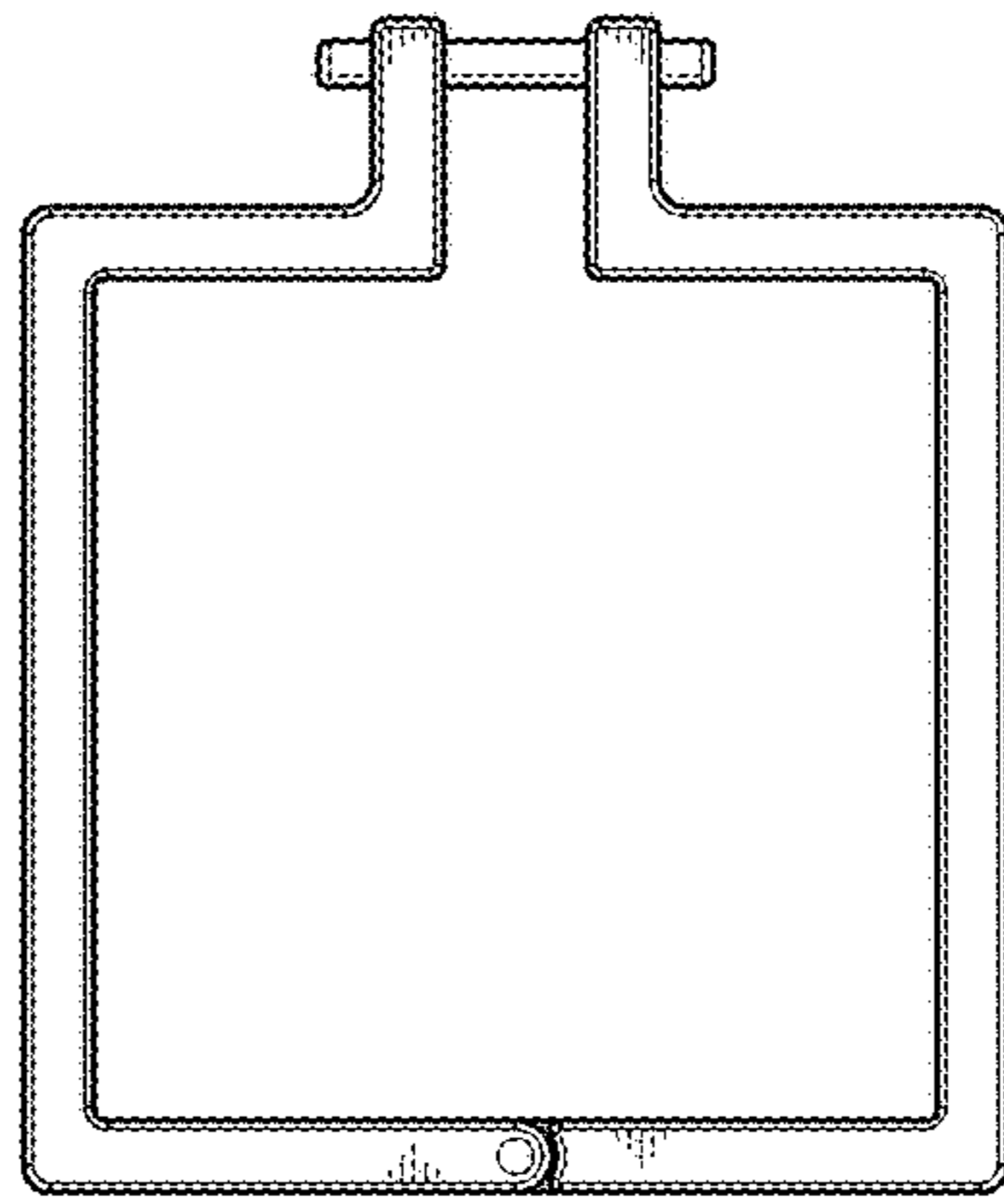

FIG. 11

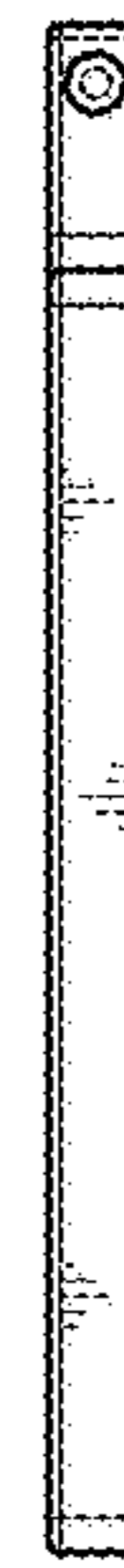

FIG. 13

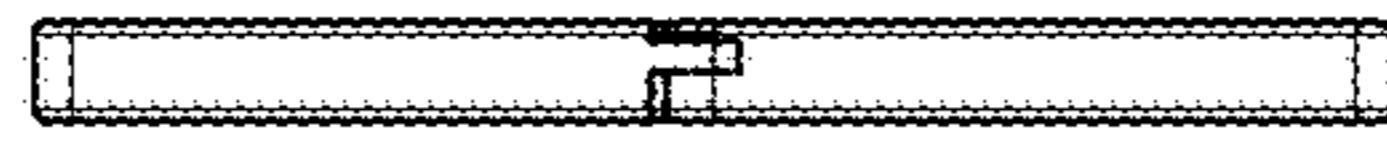

FIG. 15

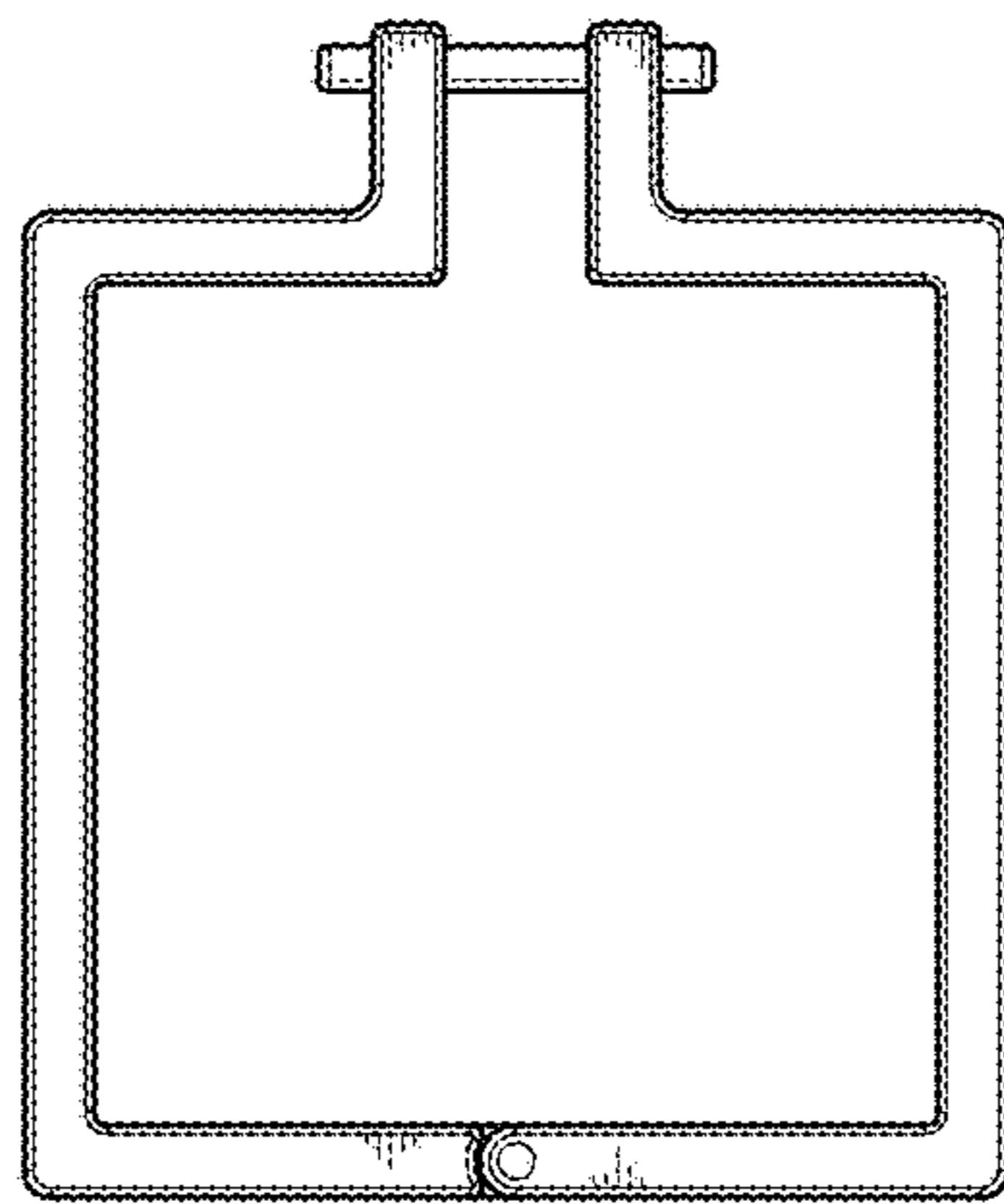

FIG. 14

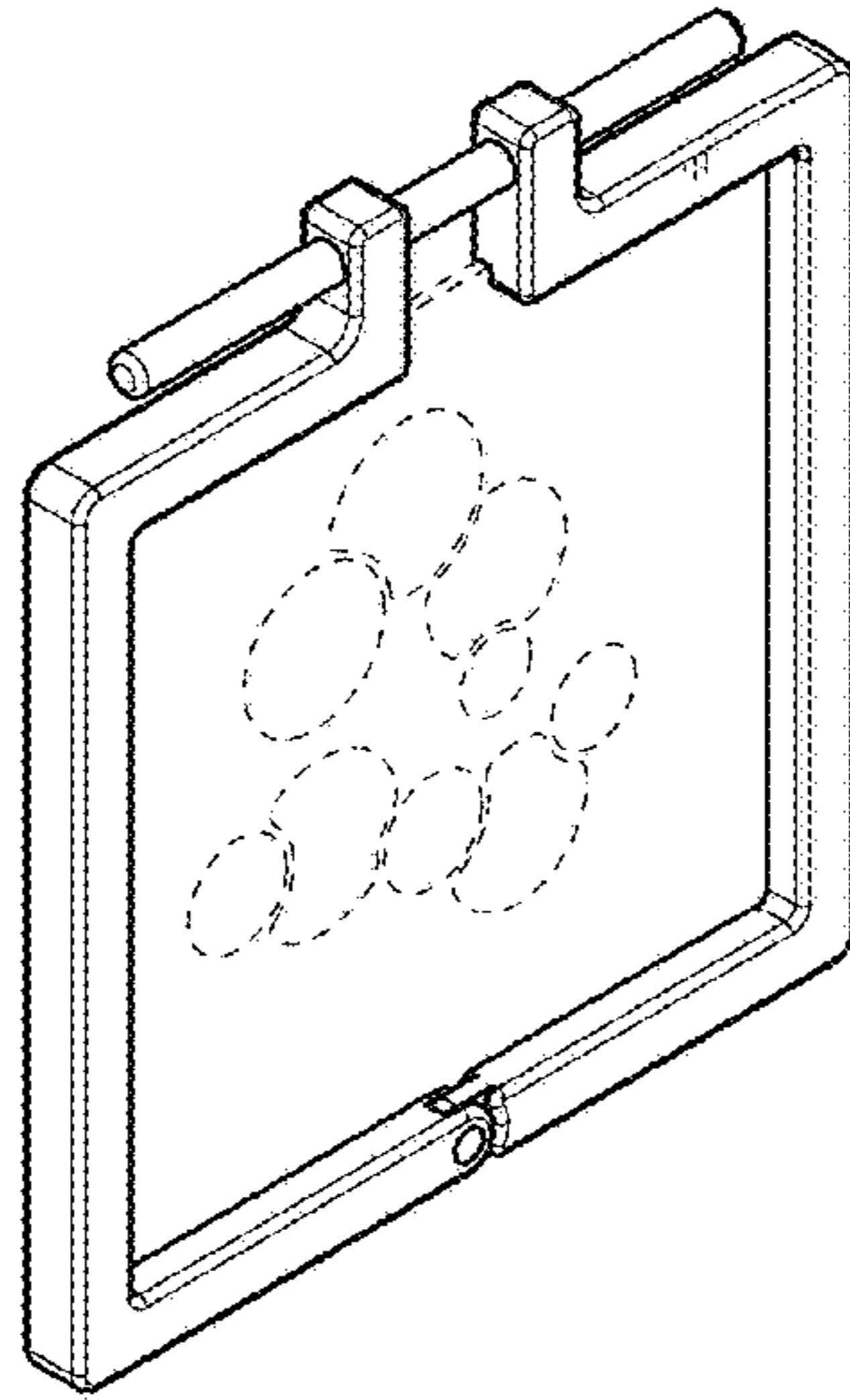

FIG. 17

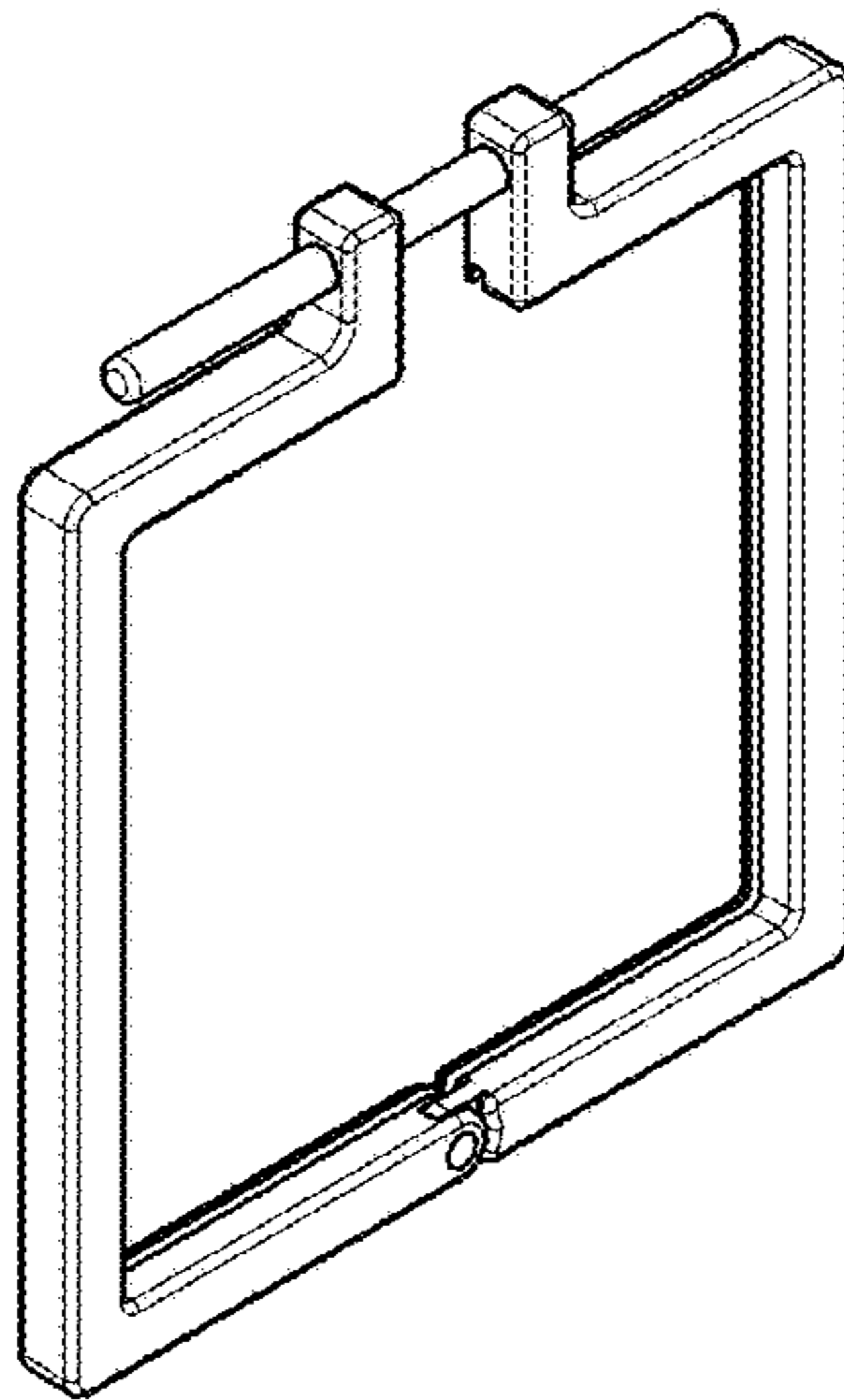

FIG. 18

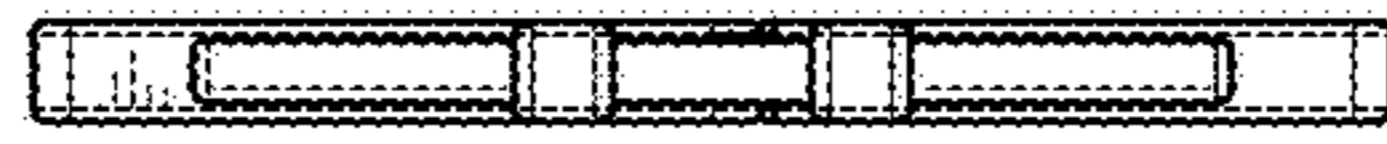

FIG. 20



FIG. 24

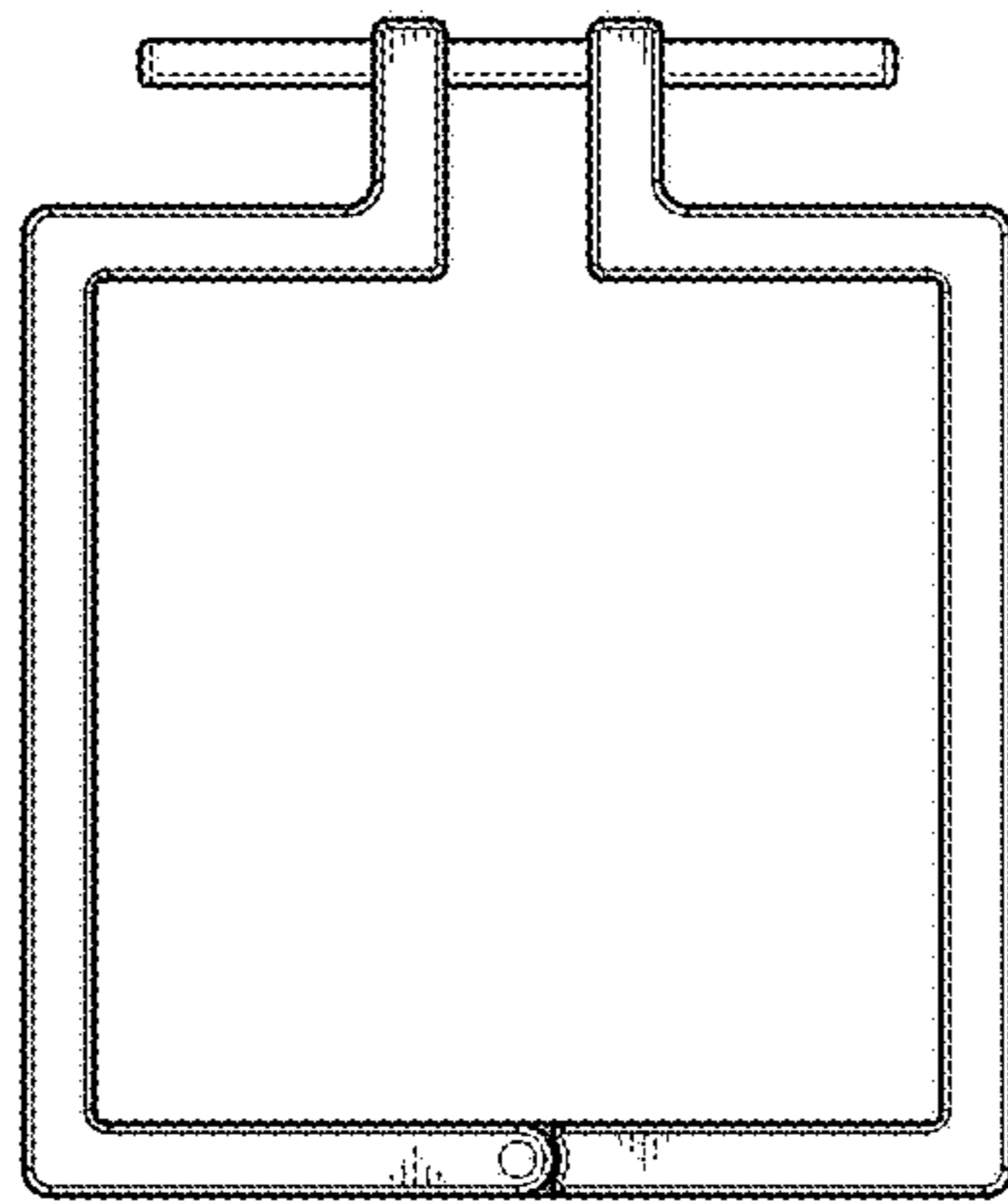

FIG. 19

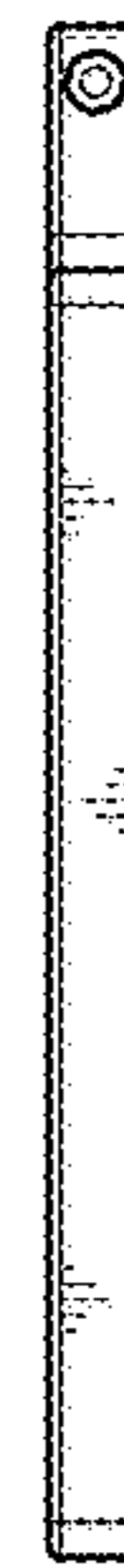

FIG. 21

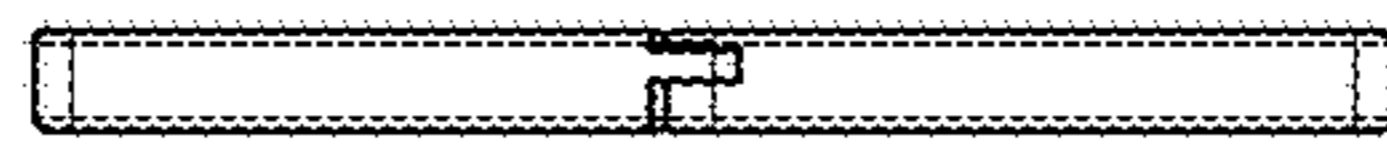

FIG. 23

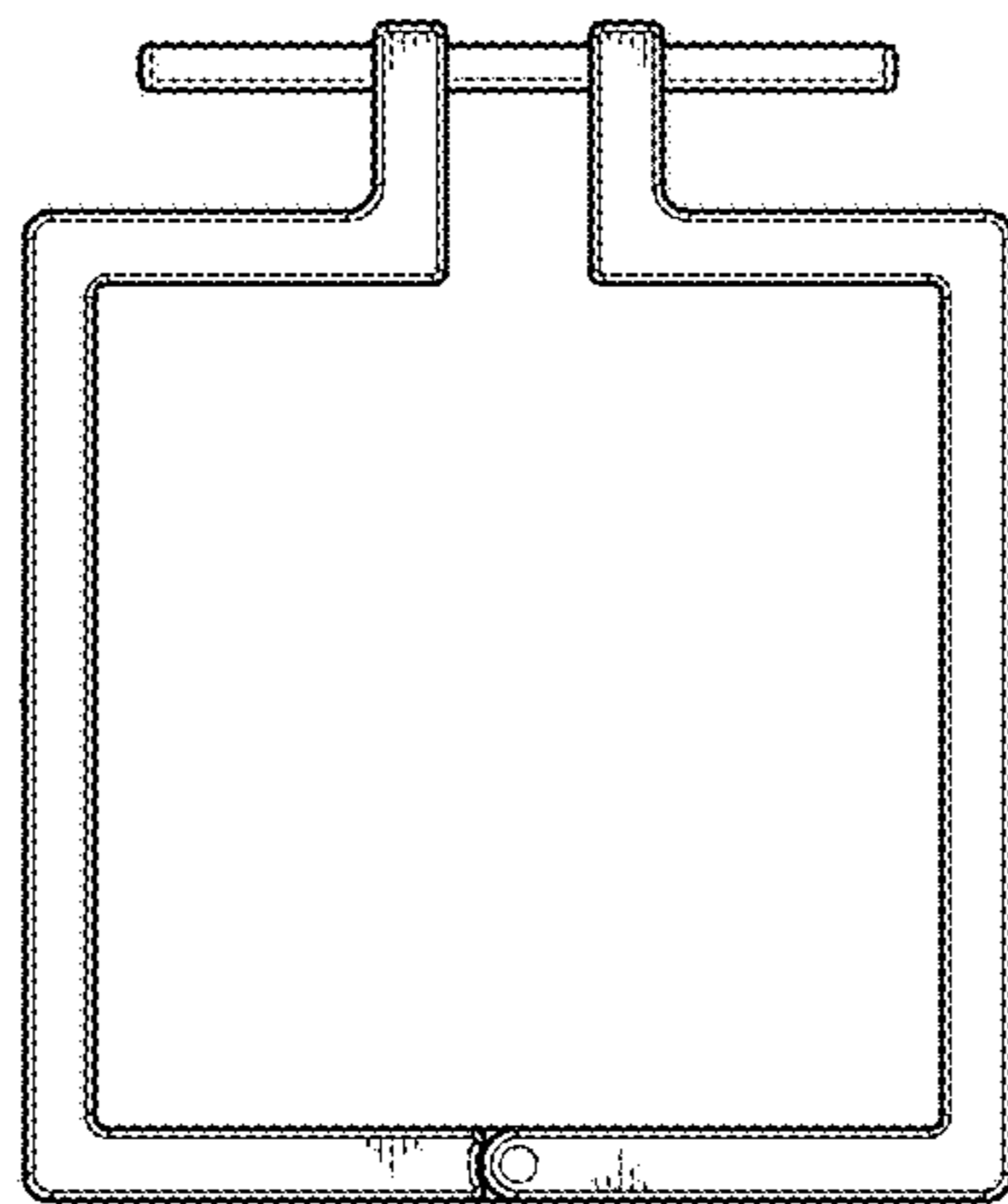

FIG. 22

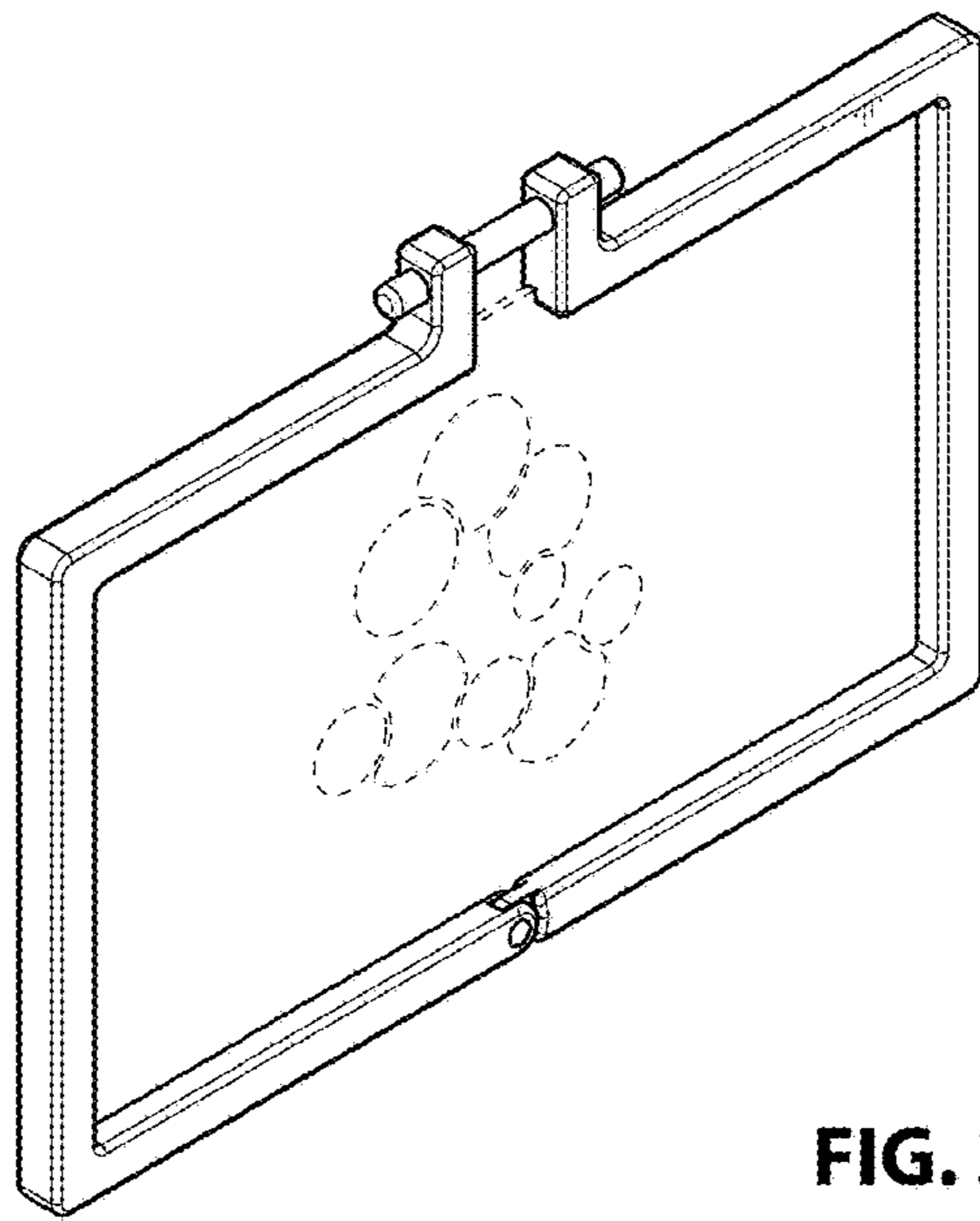

FIG. 25

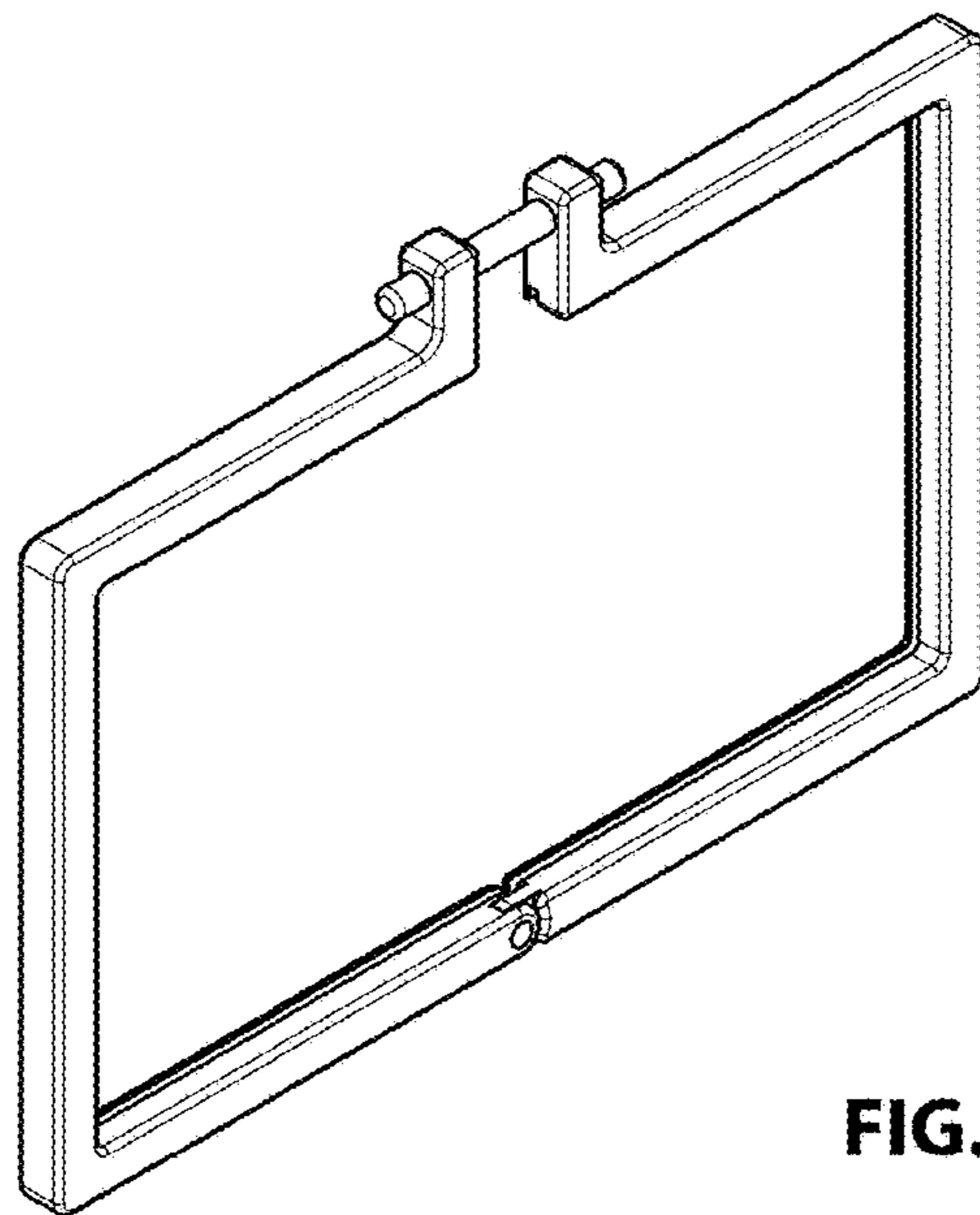

FIG. 26

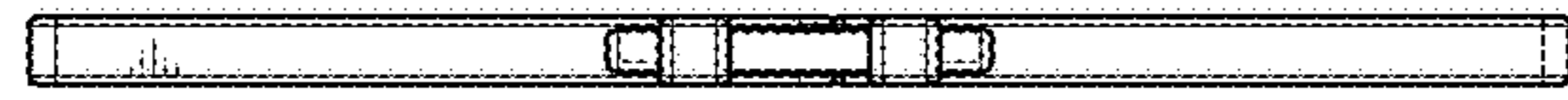

FIG. 28

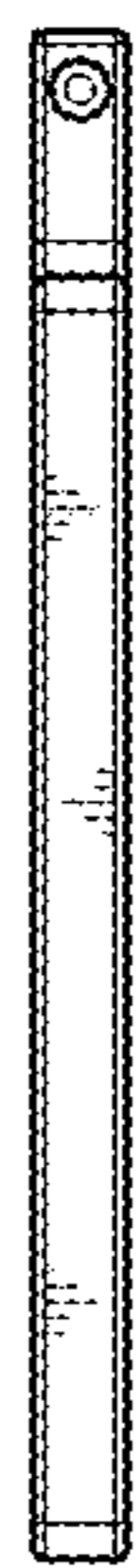

FIG. 32

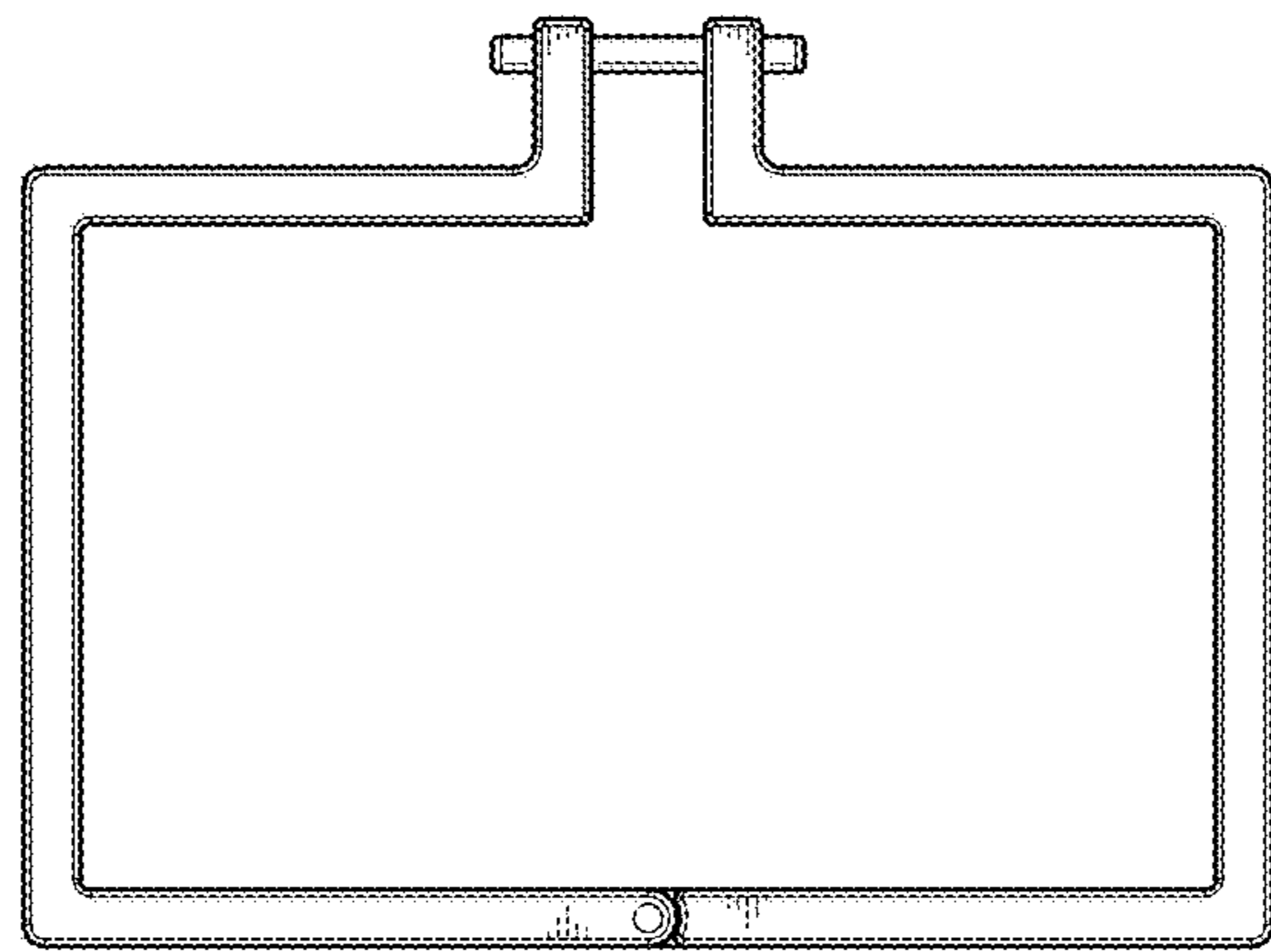

FIG. 27



FIG. 29

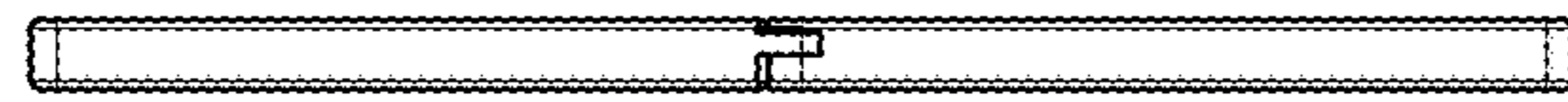

FIG. 31

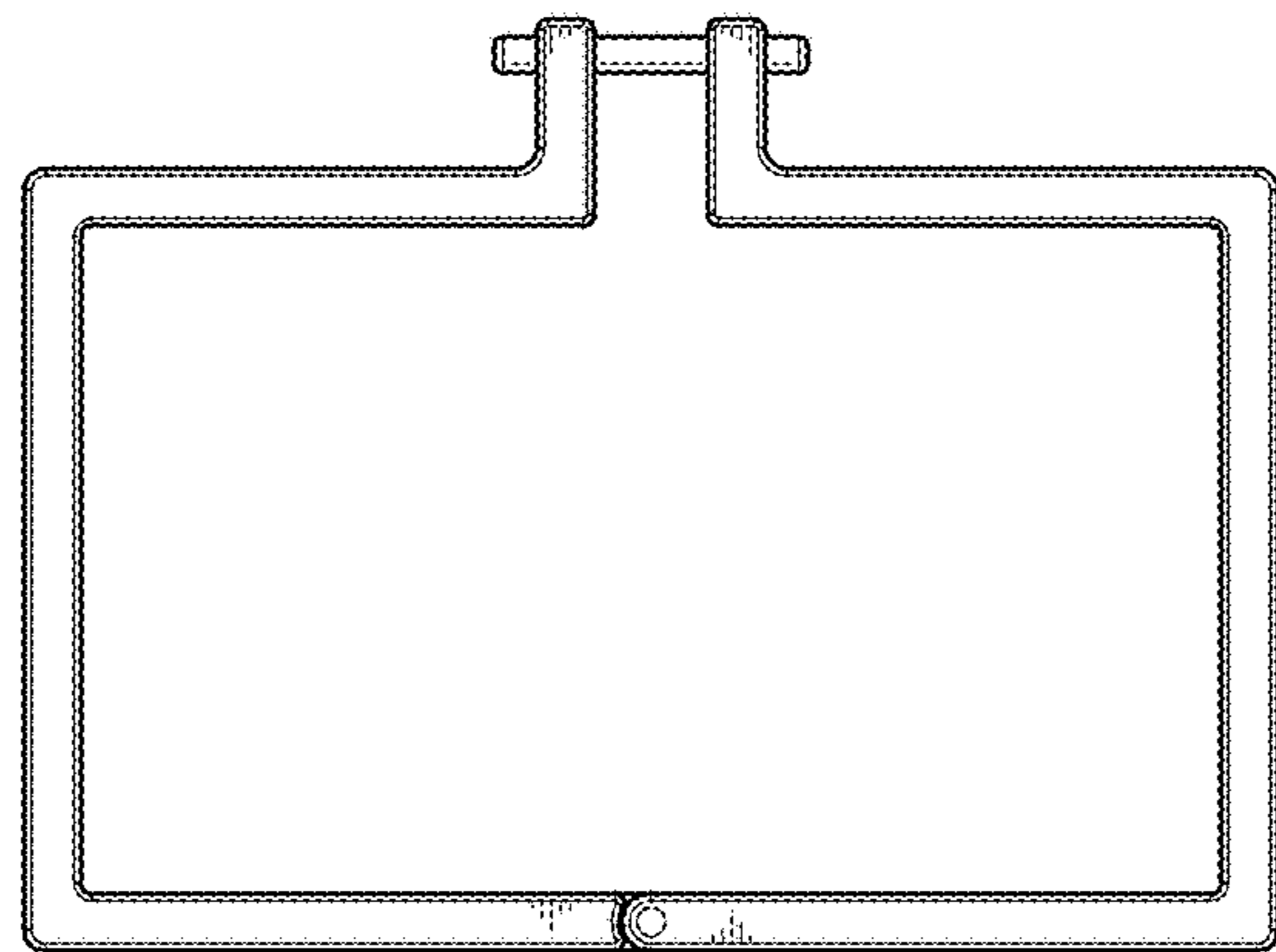

FIG. 30

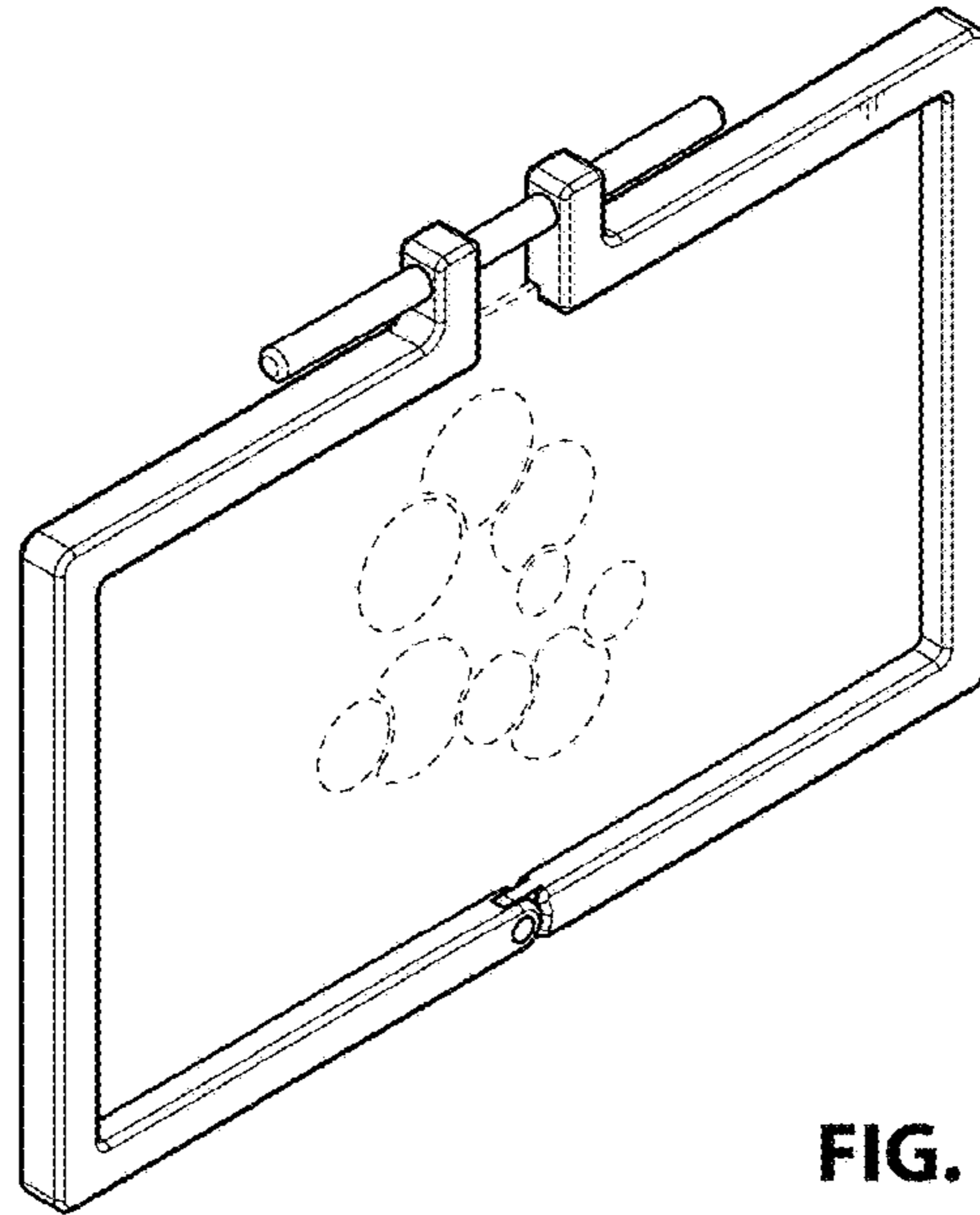

FIG. 33

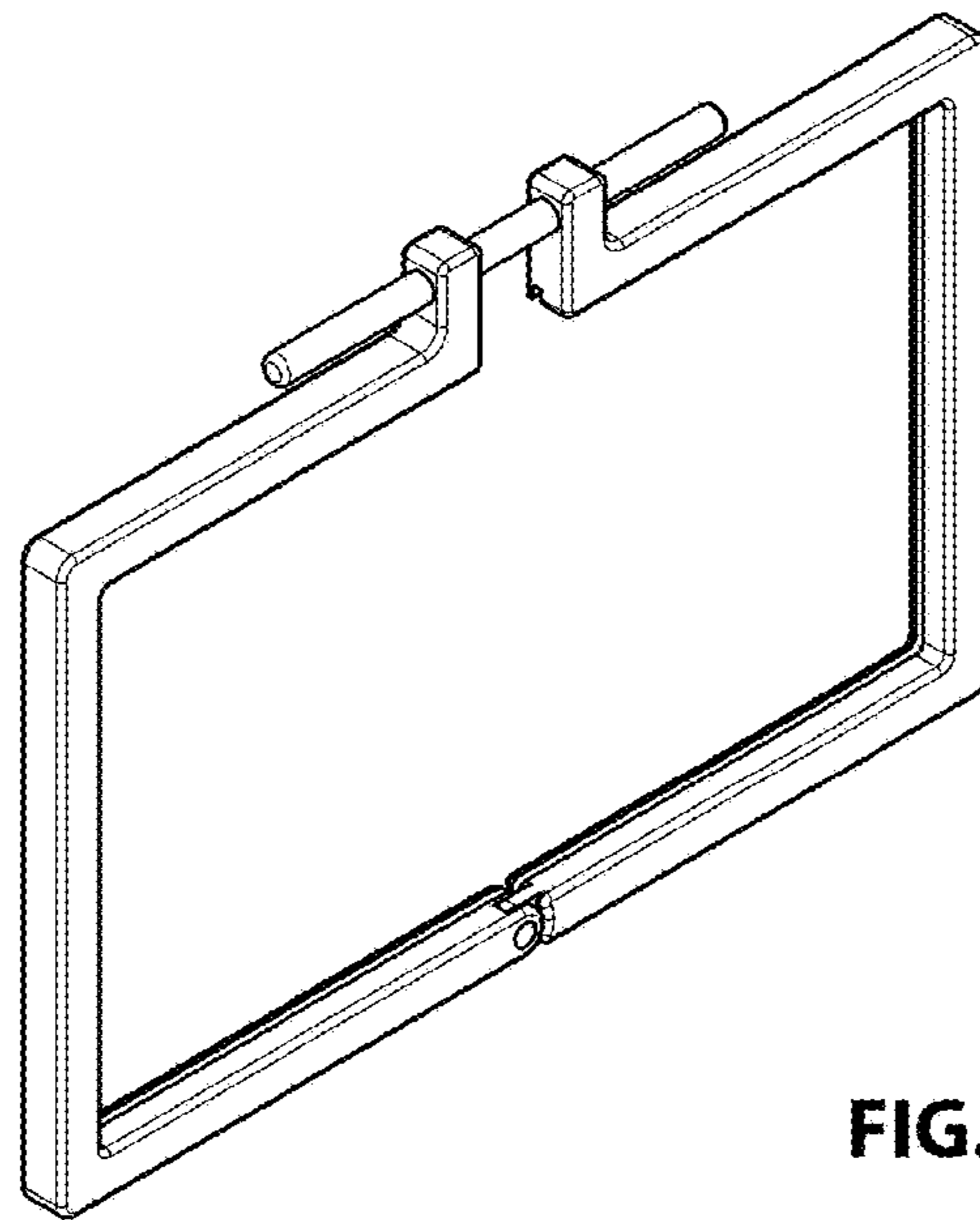

FIG. 34

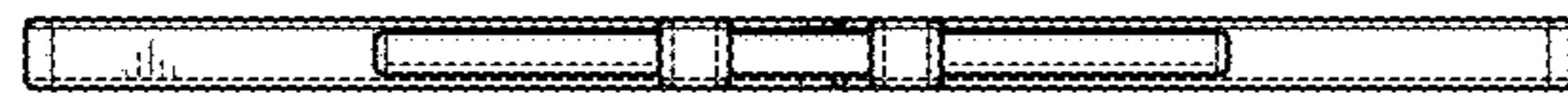

FIG. 36

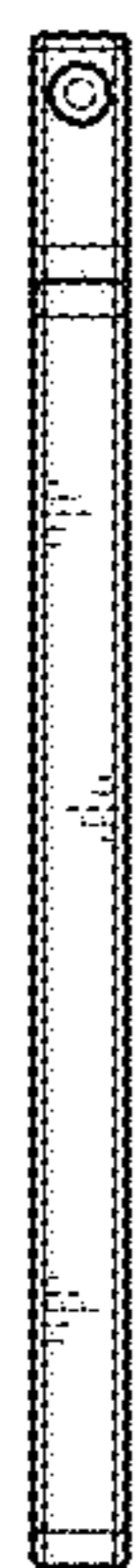

FIG. 40

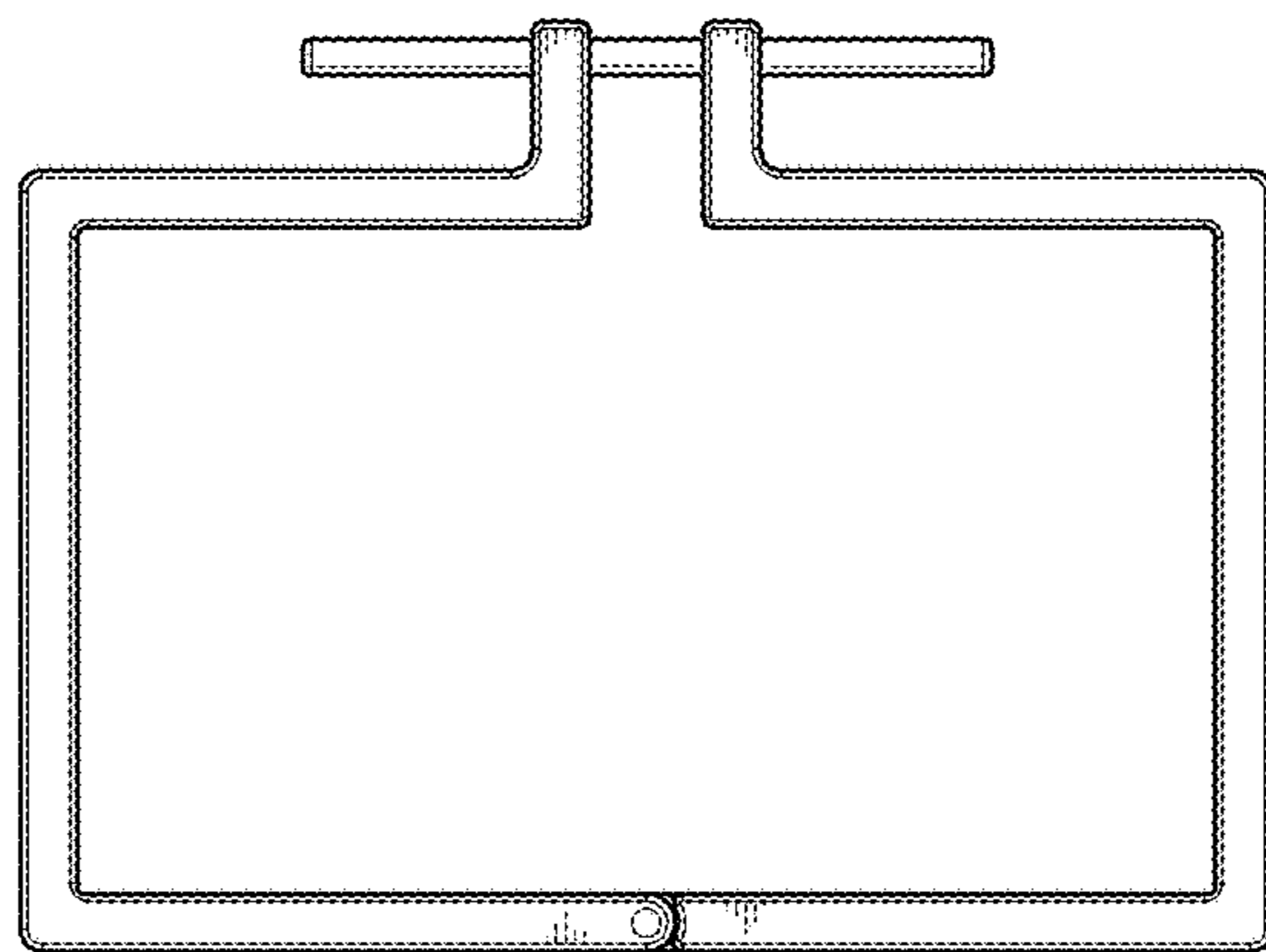

FIG. 35

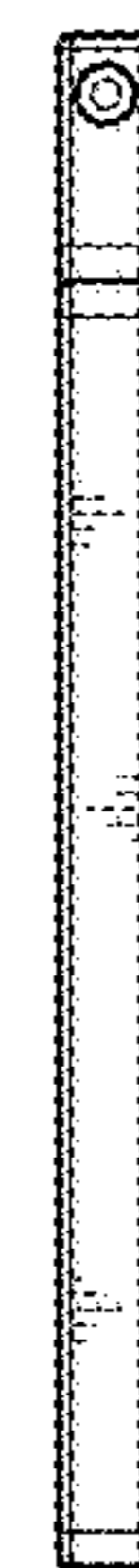

FIG. 37

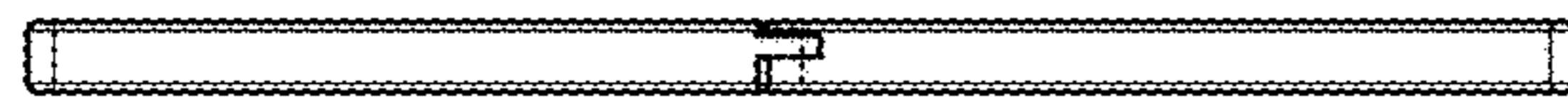

FIG. 39

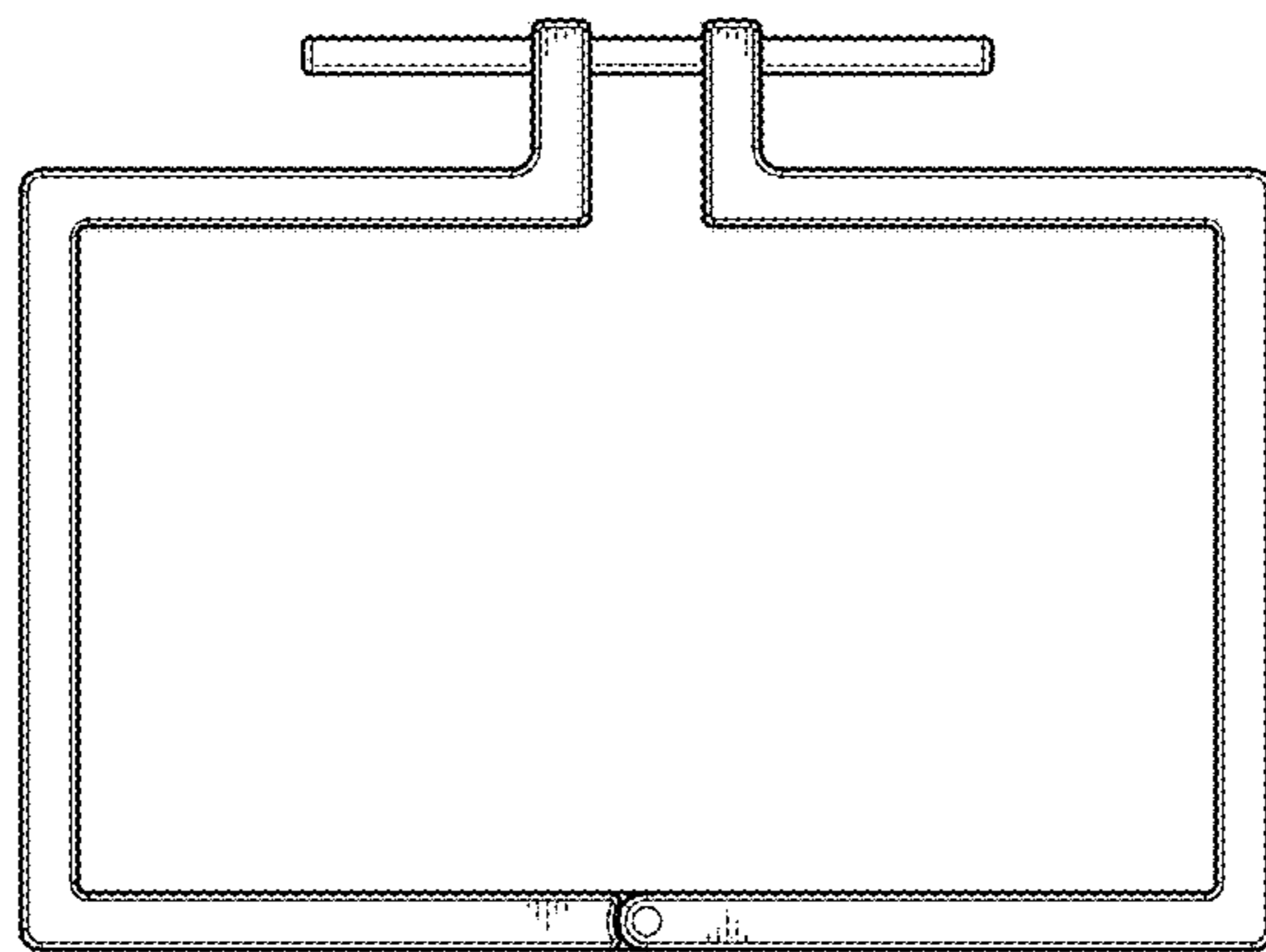

FIG. 38

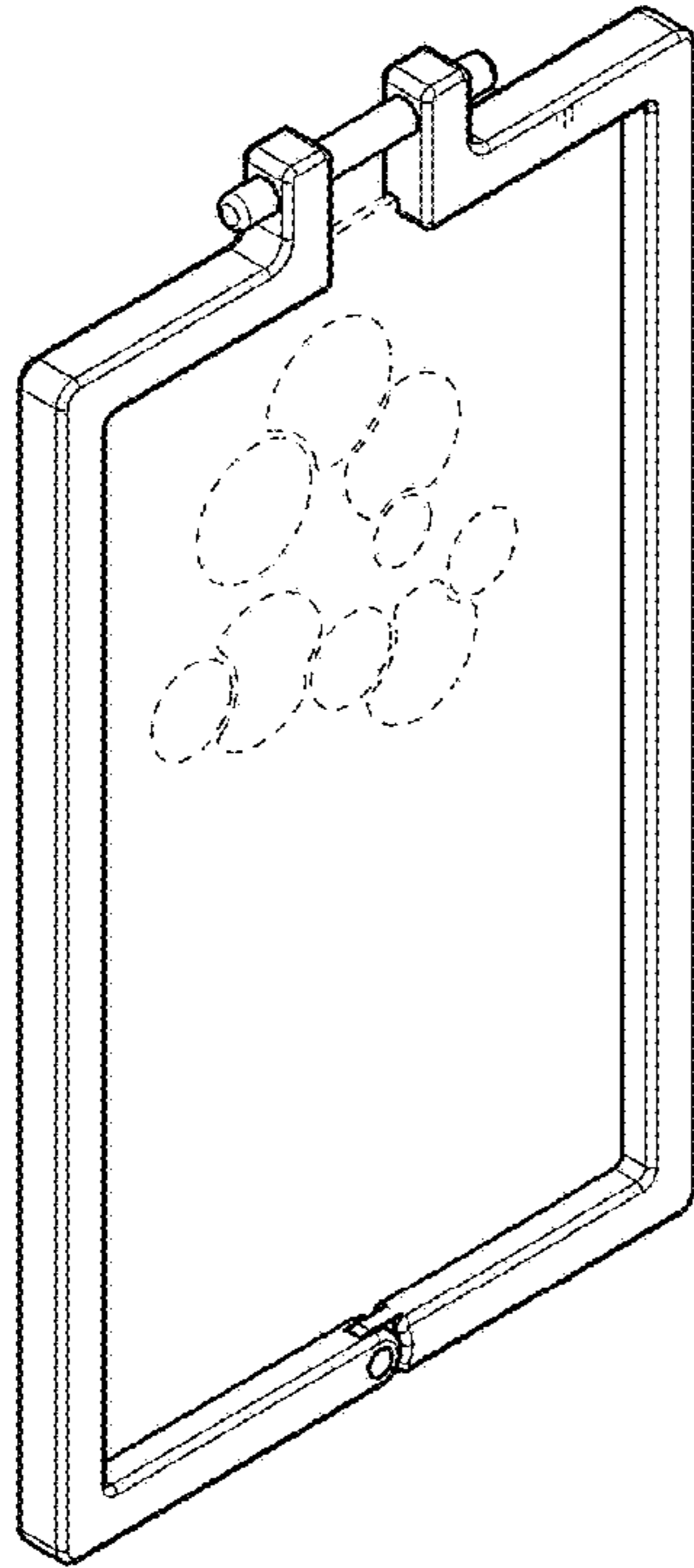

FIG. 41

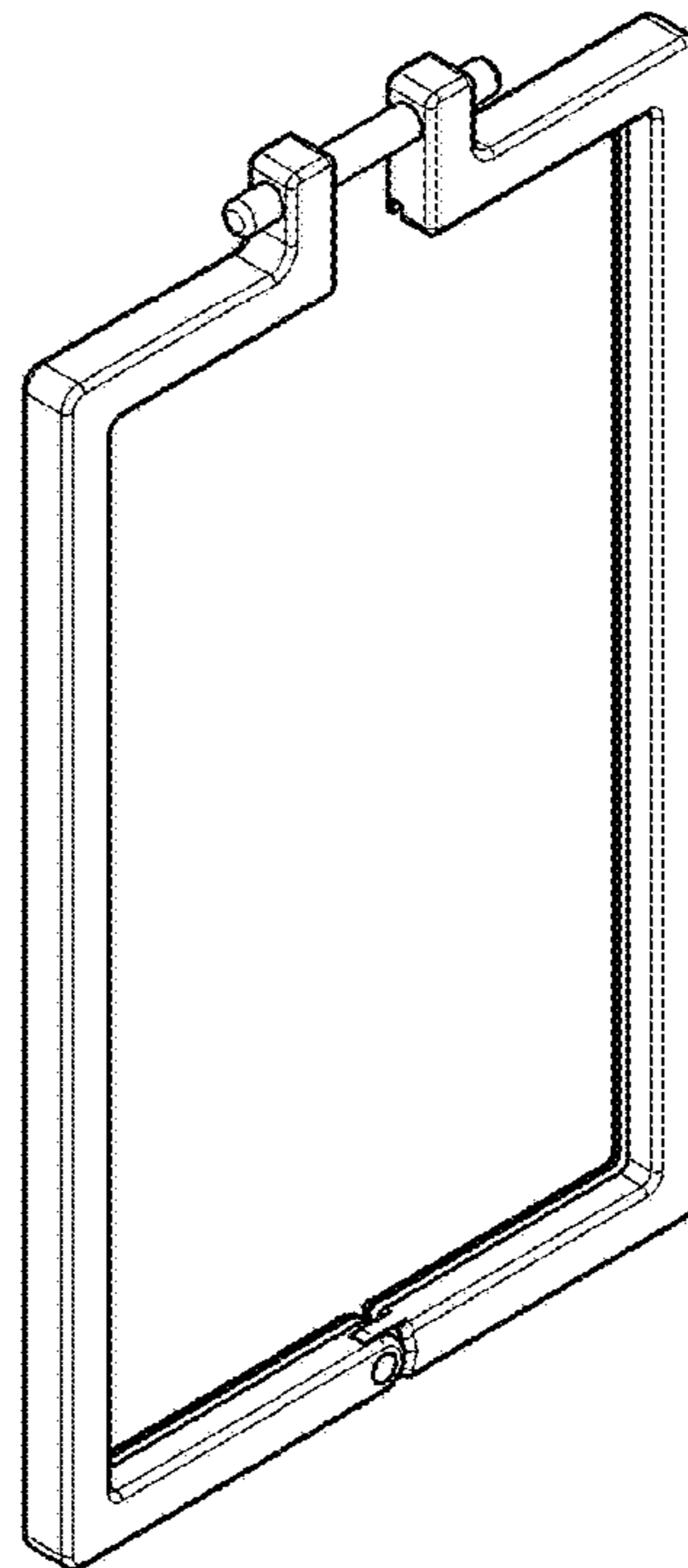

FIG. 42

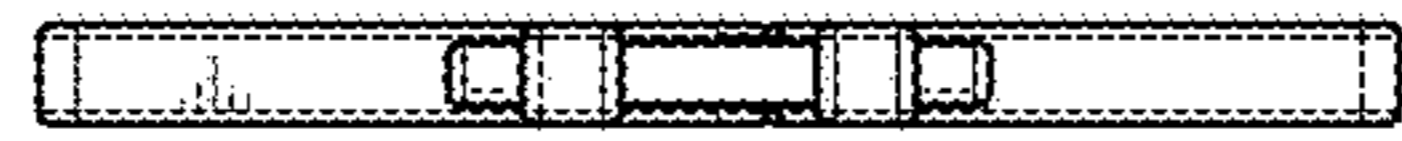

FIG. 44

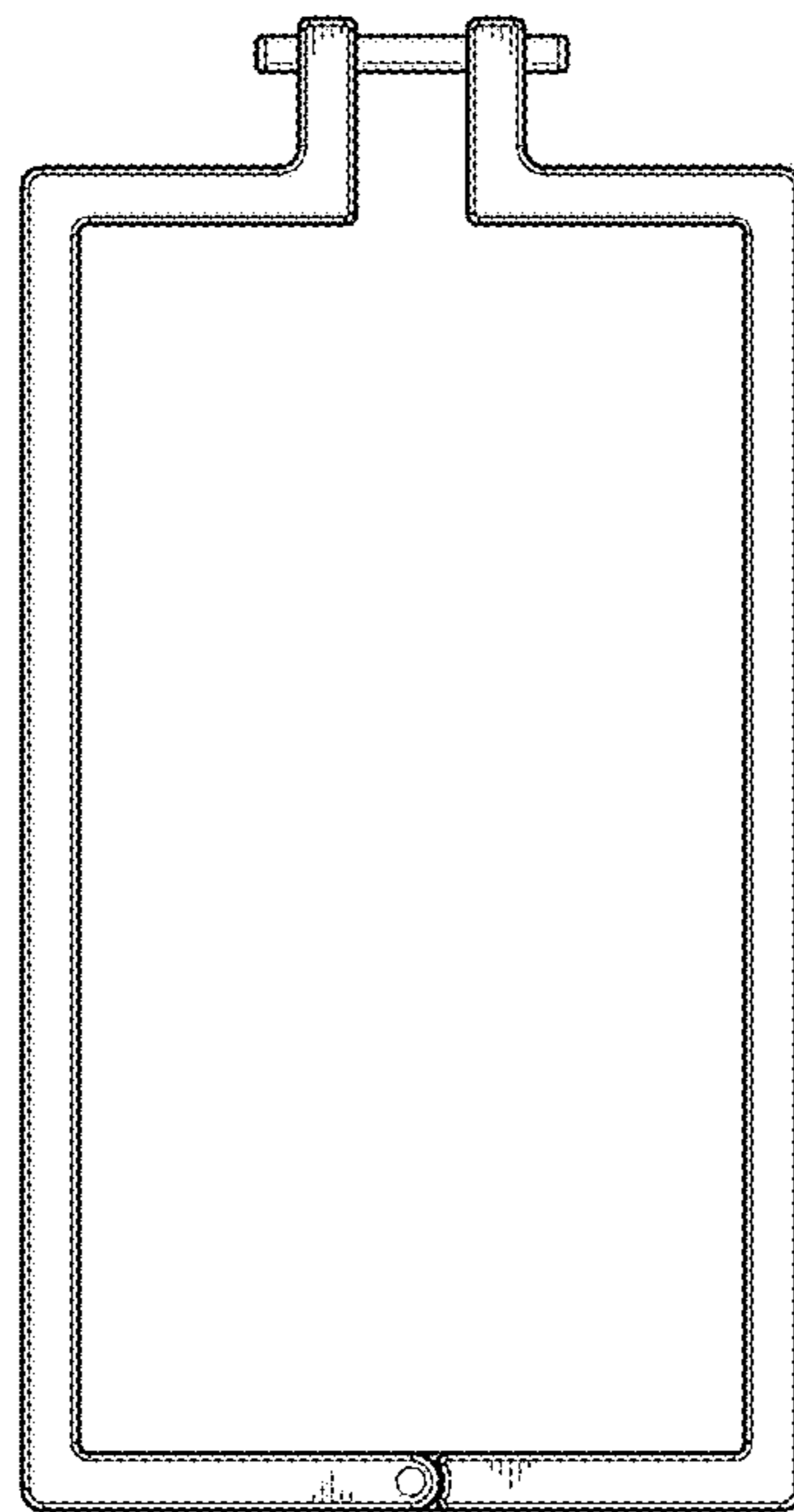

FIG. 43

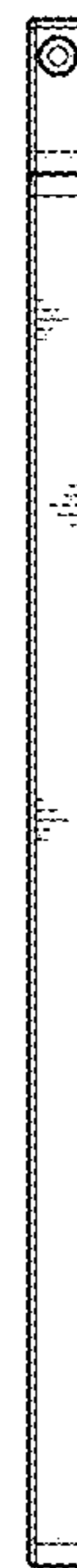

FIG. 45



FIG. 48

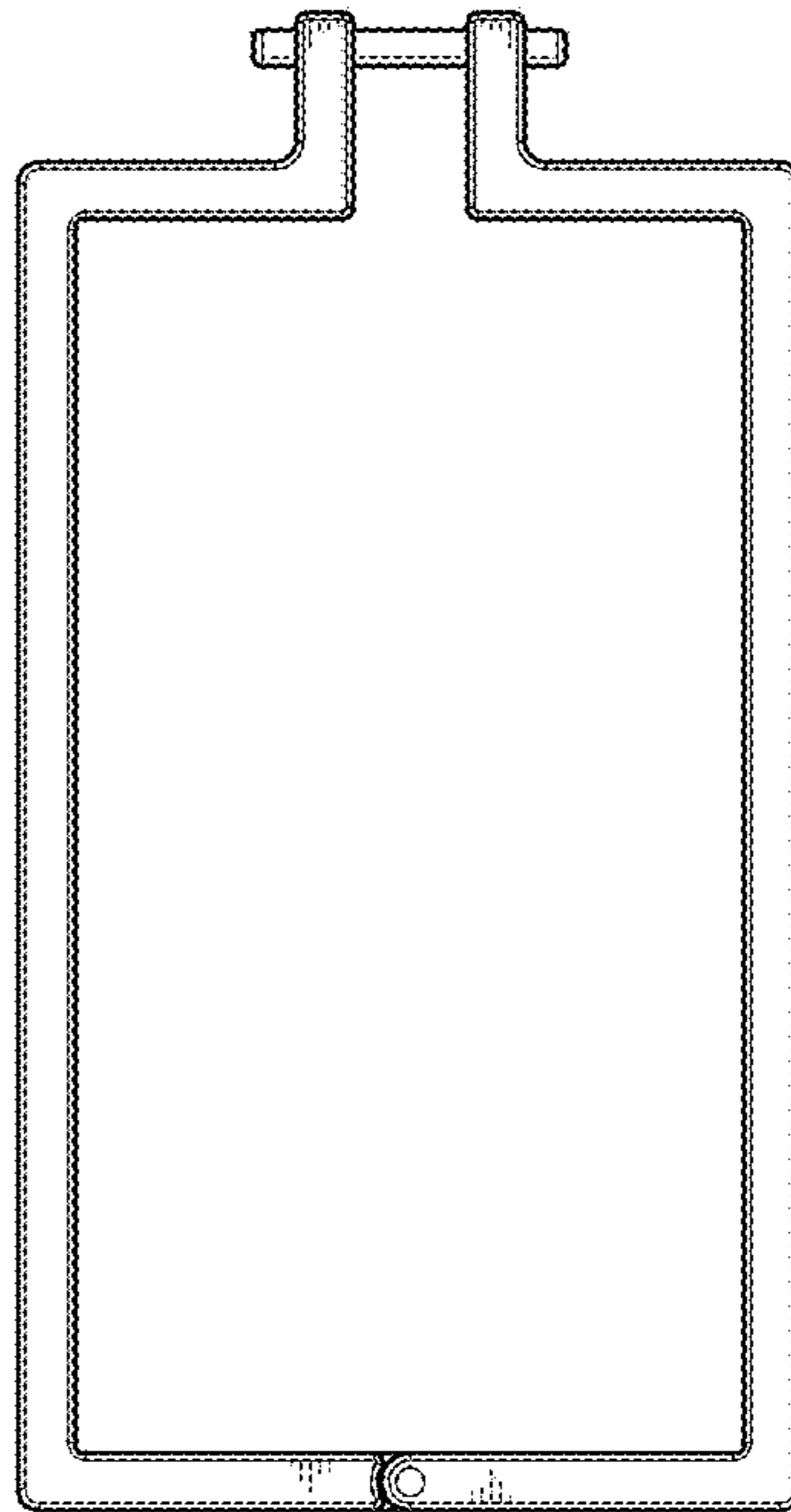

FIG. 46



FIG. 47

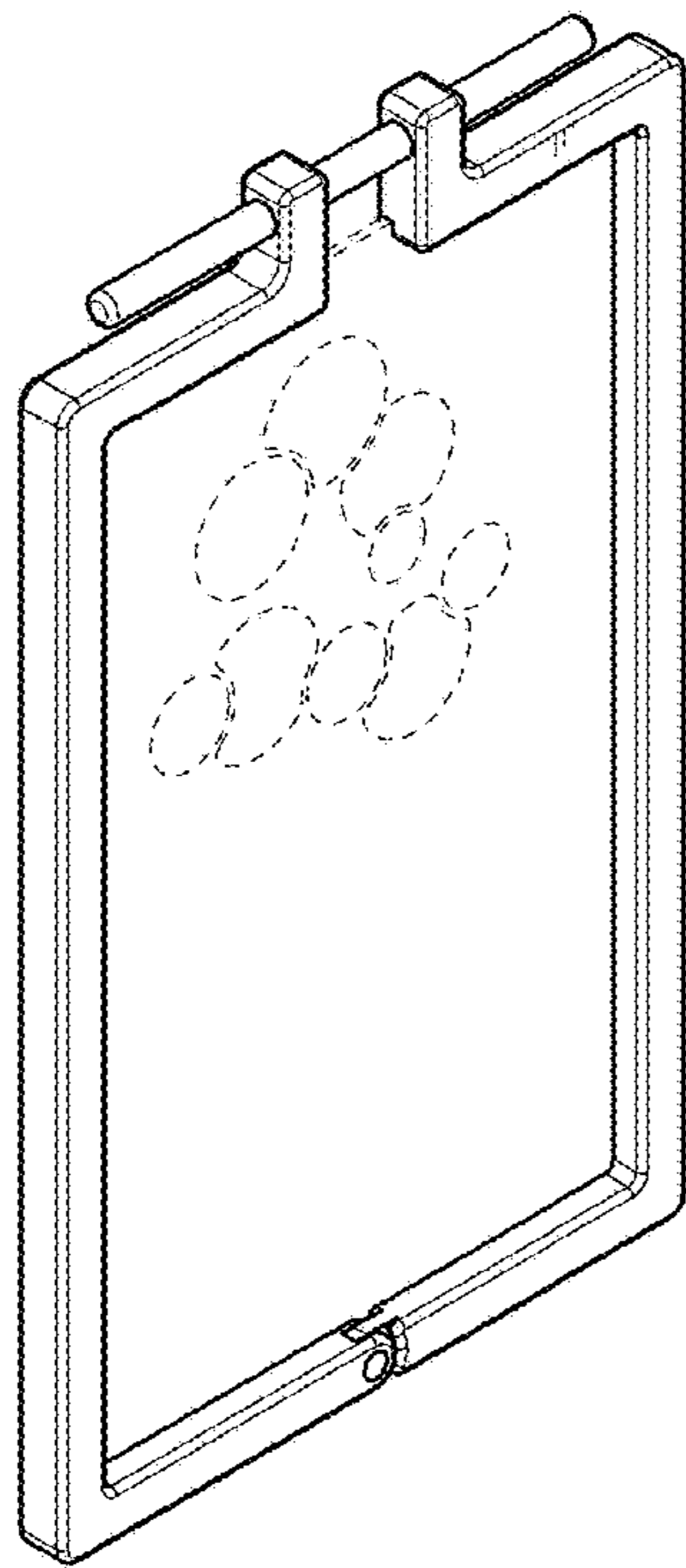

FIG. 49

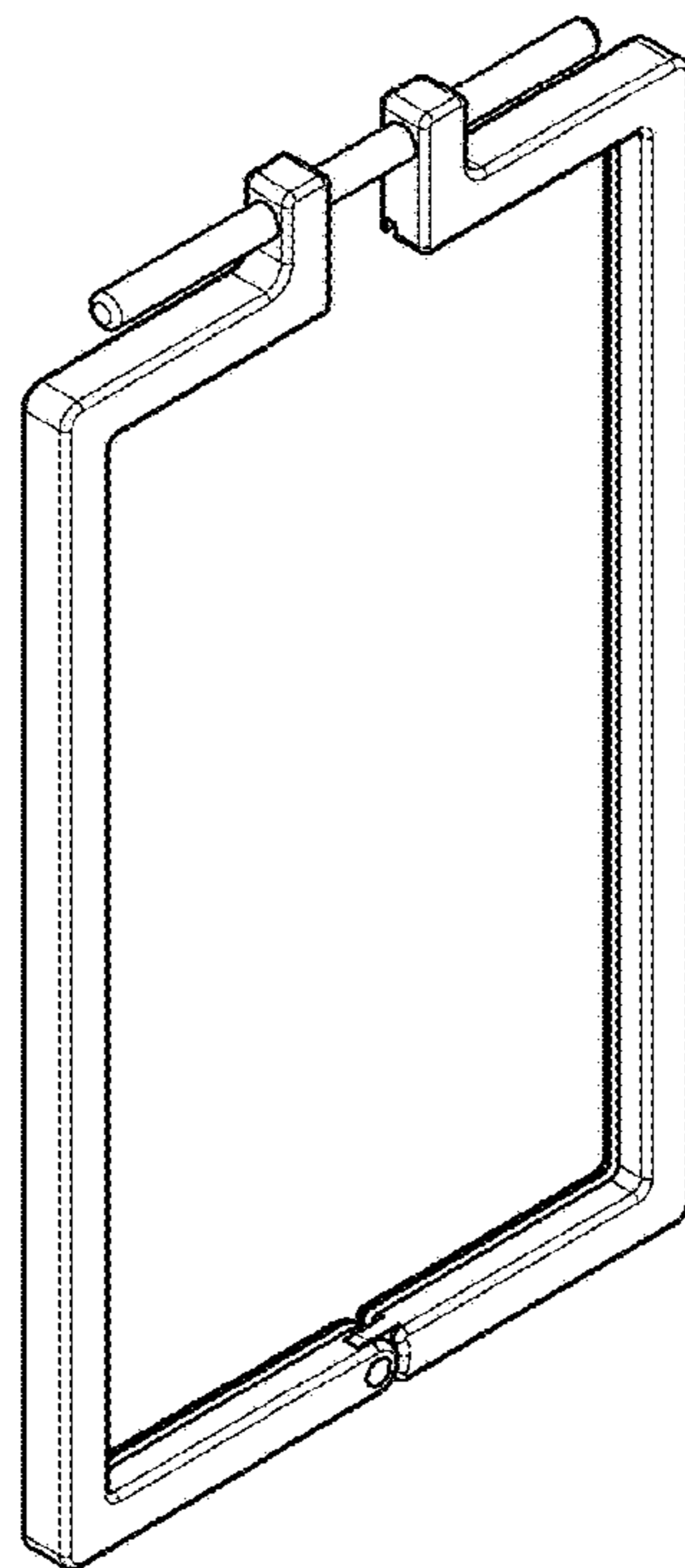

FIG. 50



FIG. 52

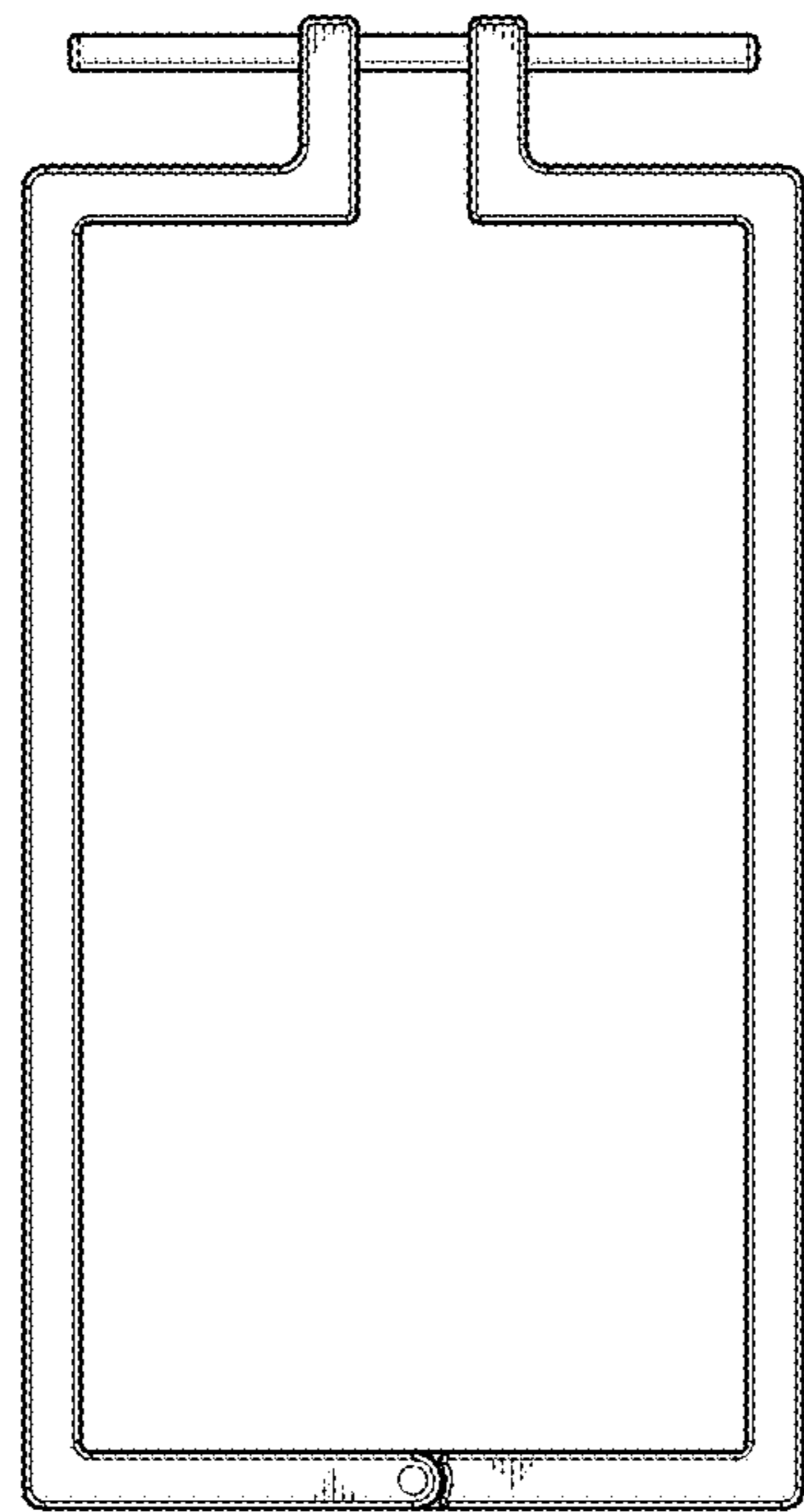

FIG. 51



FIG. 53

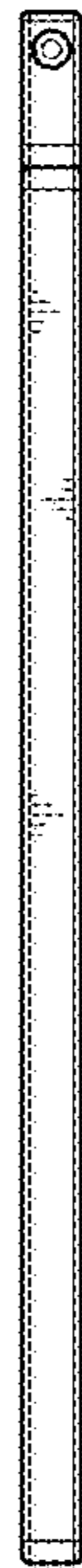

FIG. 56

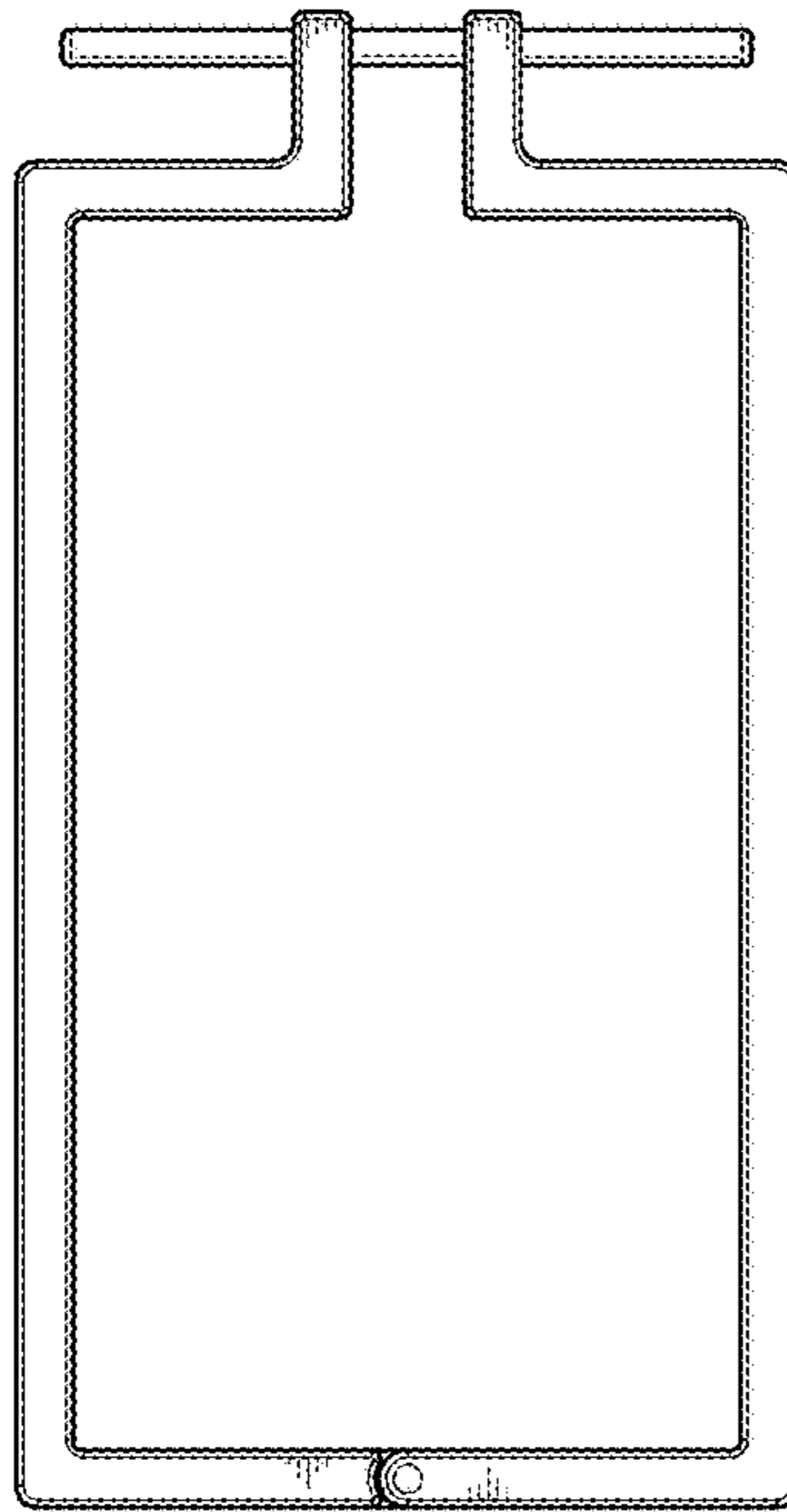

FIG. 54

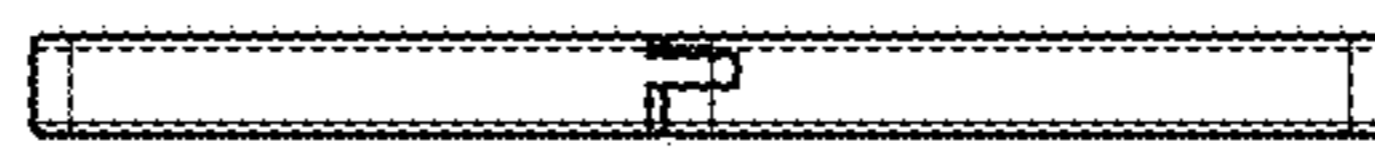

FIG. 55